

TABLE

Assembly Instructions

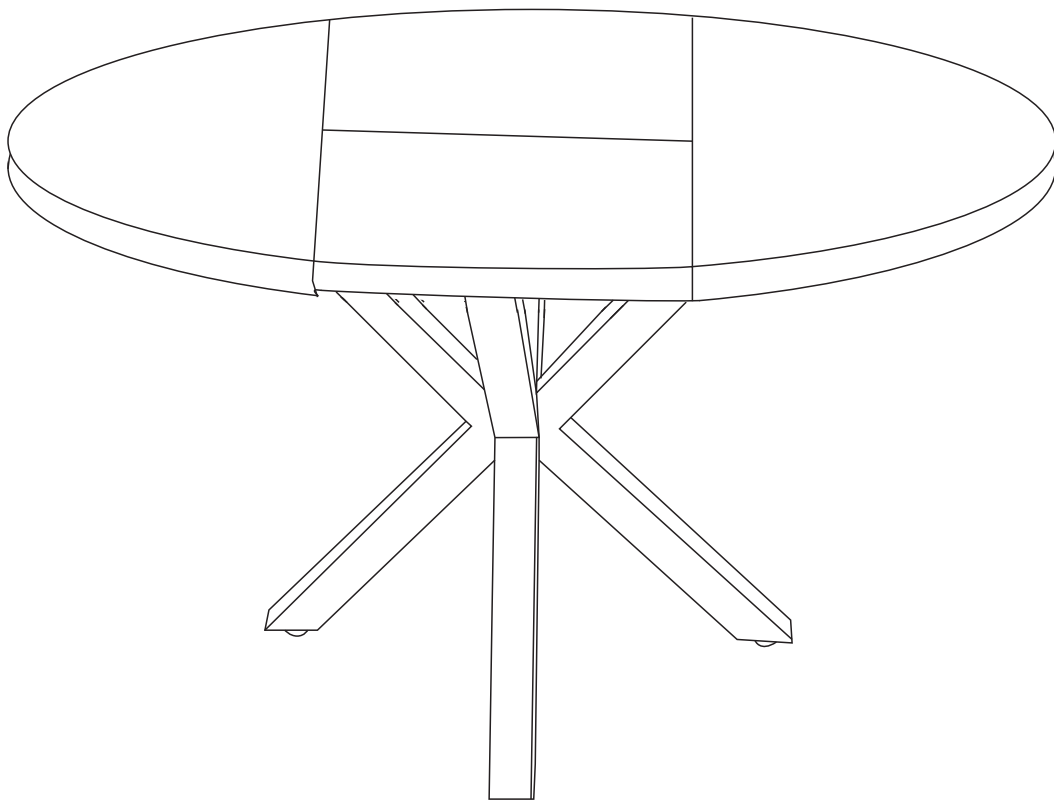

General Assembly Guidelines

- I. Ensure that all parts and hardware are available before beginning assembly.
- II. Follow each step carefully to ensure the proper assembly of this product.
- III. Two people are recommended for ease in the assembly of this product.
- IV. If there are accessories missing or any other problems, please contact the seller first.
- V. Power tools should not be used to assemble this product.

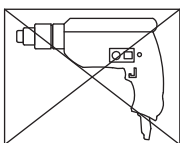

- VI. A Phillips head screwdriver is required for the assembly of this product (not included).

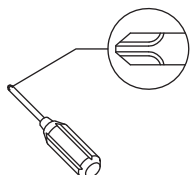

Parts List

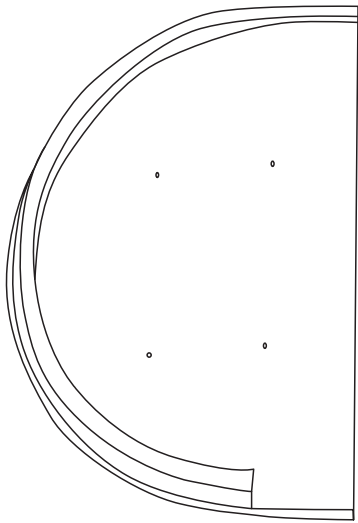

Board Ax2

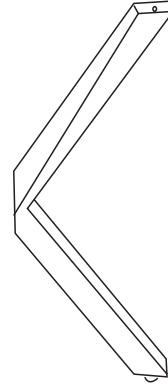

Leg Dx2

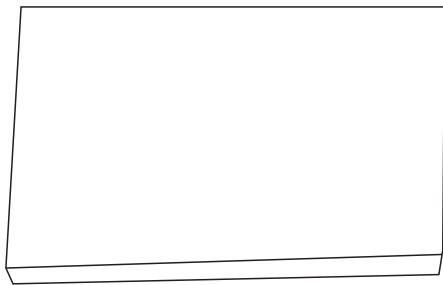

Board Bx1

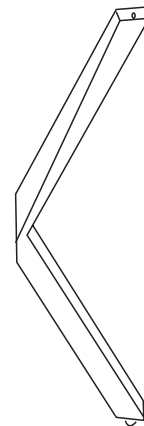

Leg Ex2

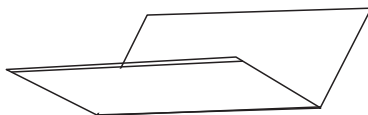



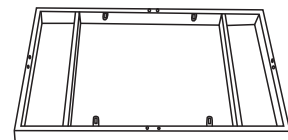















Board Cx1



Leg Fx1

Hardware List

G			Connection	1	PCS
H			Skidway	2	PCS
I			Connection	1	PCS
J			Connection	1	PCS
K		8x18mm	Shim	8	PCS
L		6x18mm	Shim	23	PCS
M			Spring washer	8	PCS
N		6x16mm	Bolt	16	PCS
O		6x13mm	Bolt	7	PCS
P		6x10mm	Bolt	8	PCS
Q		8x16mm	Bolt	8	PCS
R			Bolt	16	PCS
S			Foot	4	PCS
T			Pull button	4	PCS
U			Hex Key	1	PCS
V			Hex Key	1	PCS
W			Hex Key	1	PCS
X			Leveling pad	4	PCS

*The hardware quantities listed above are required for proper assembly.
Some extra hardware may also have been included.*

Step 1

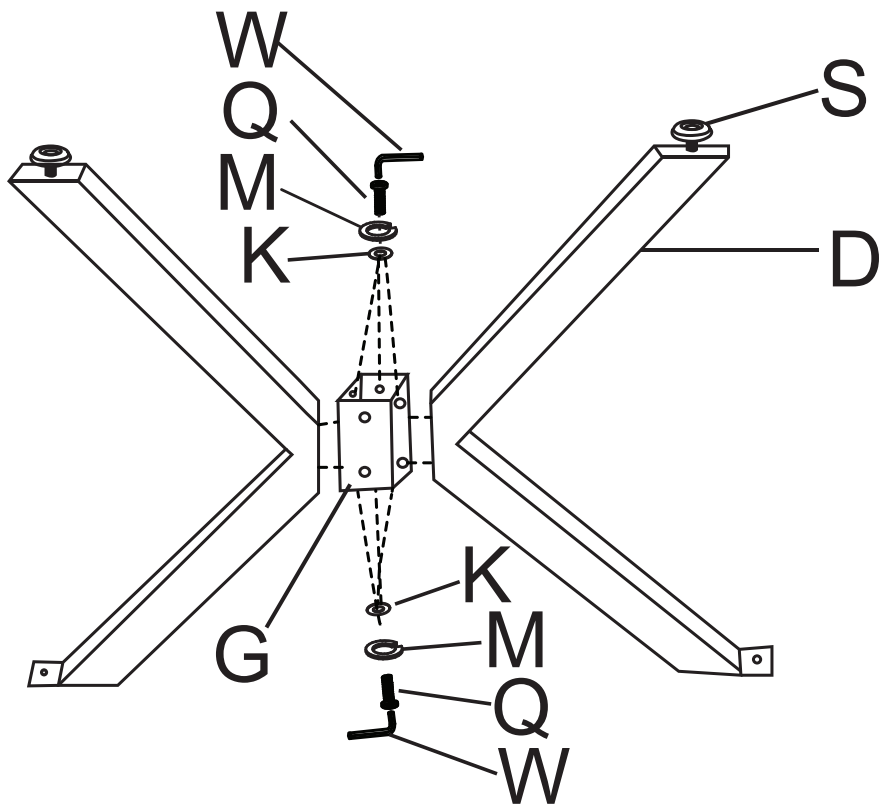
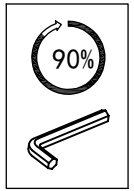

Step 2

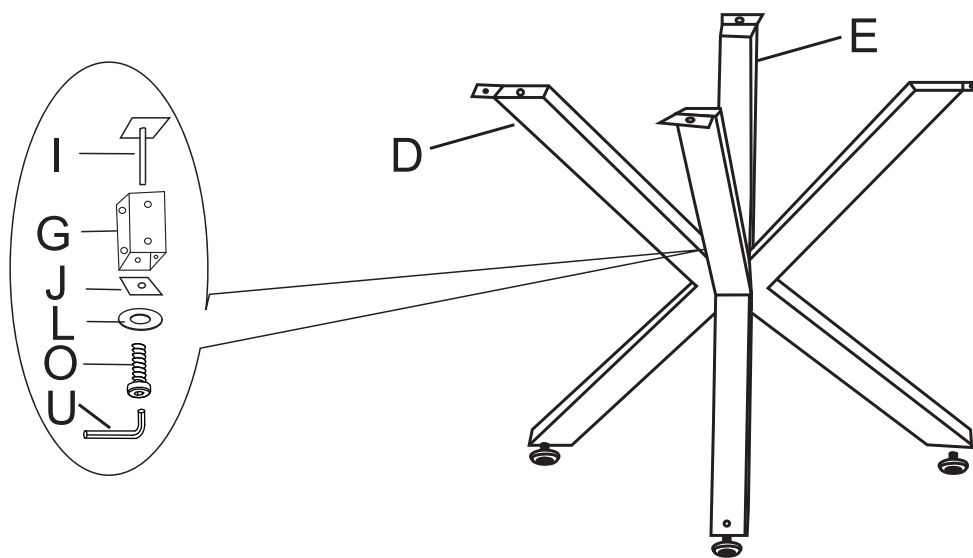
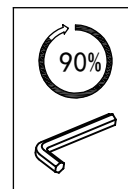

Step 3

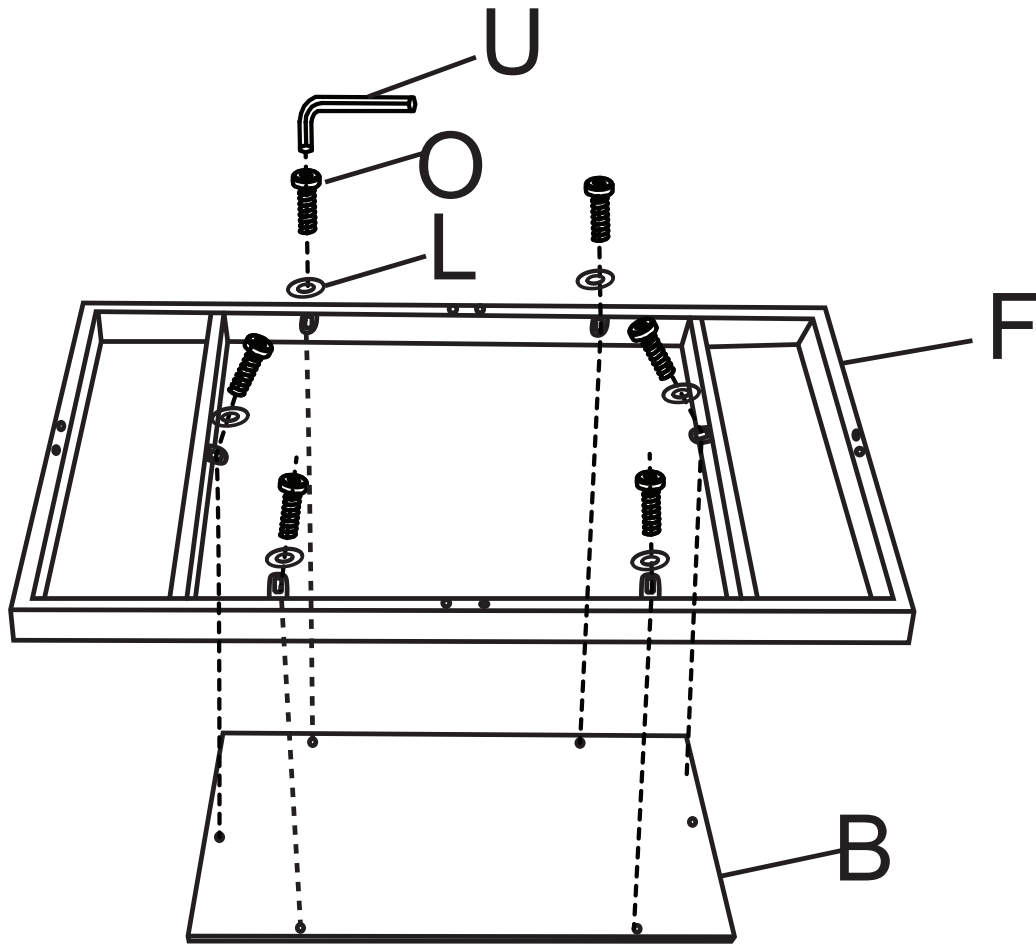
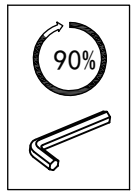

Step 4

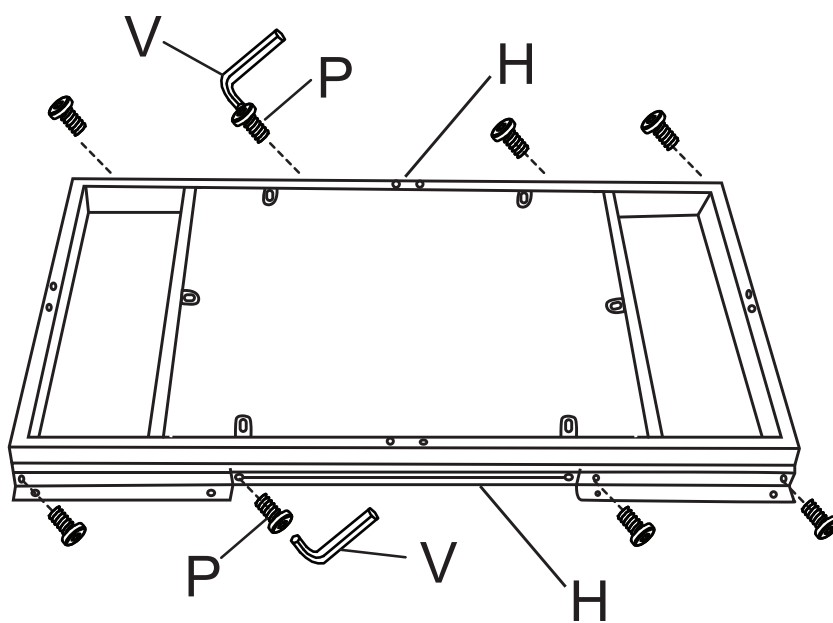
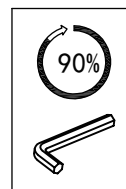

Step 5

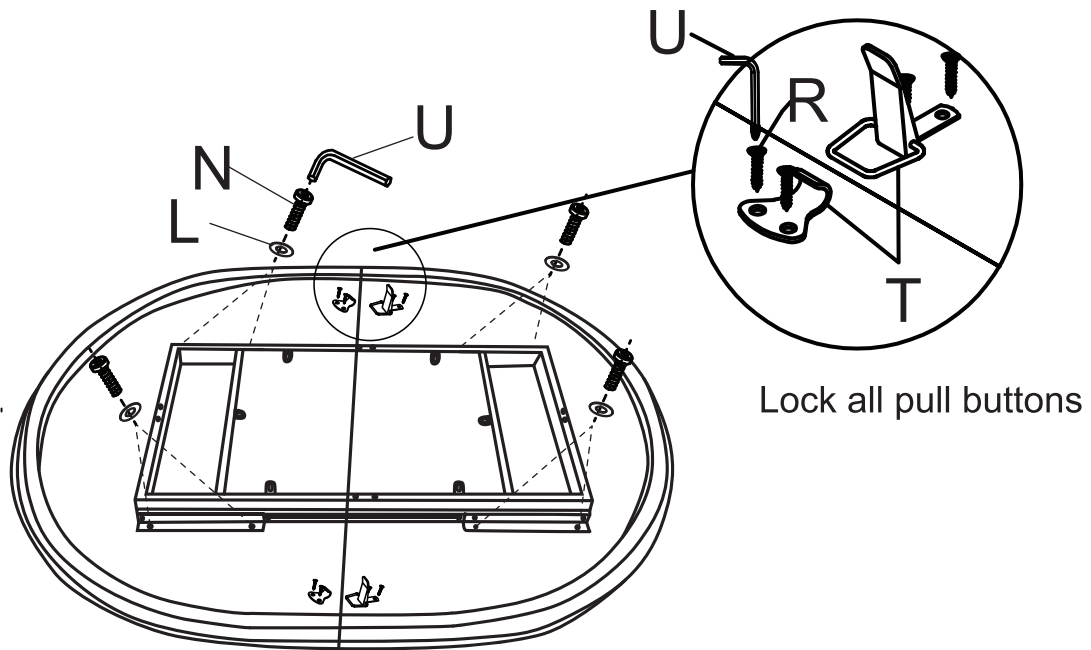
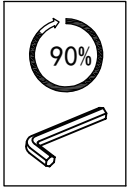

Step 6

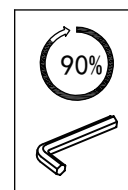

Lock it before flip the table

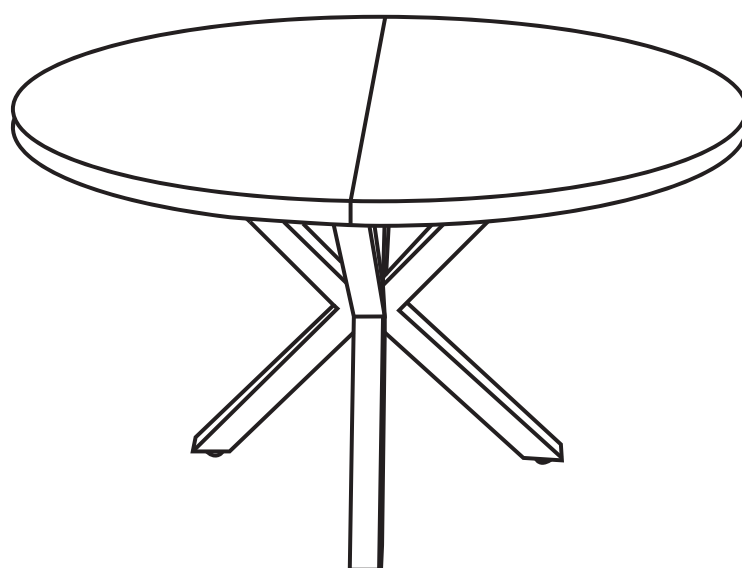
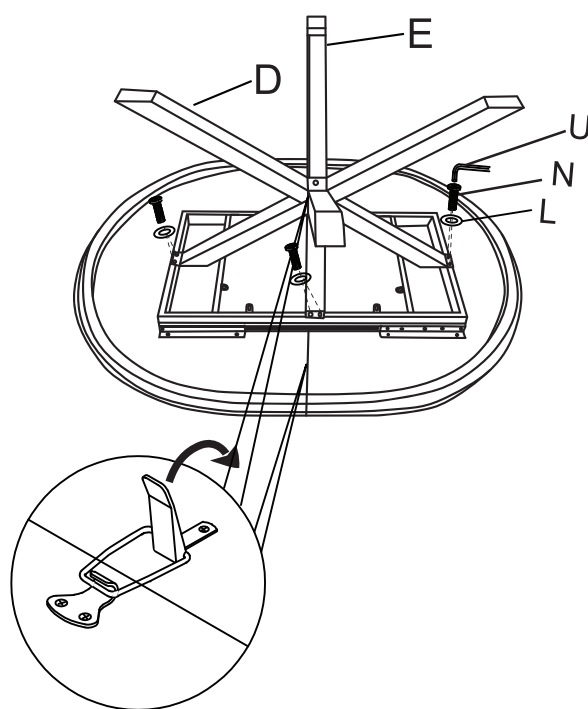

Step 7

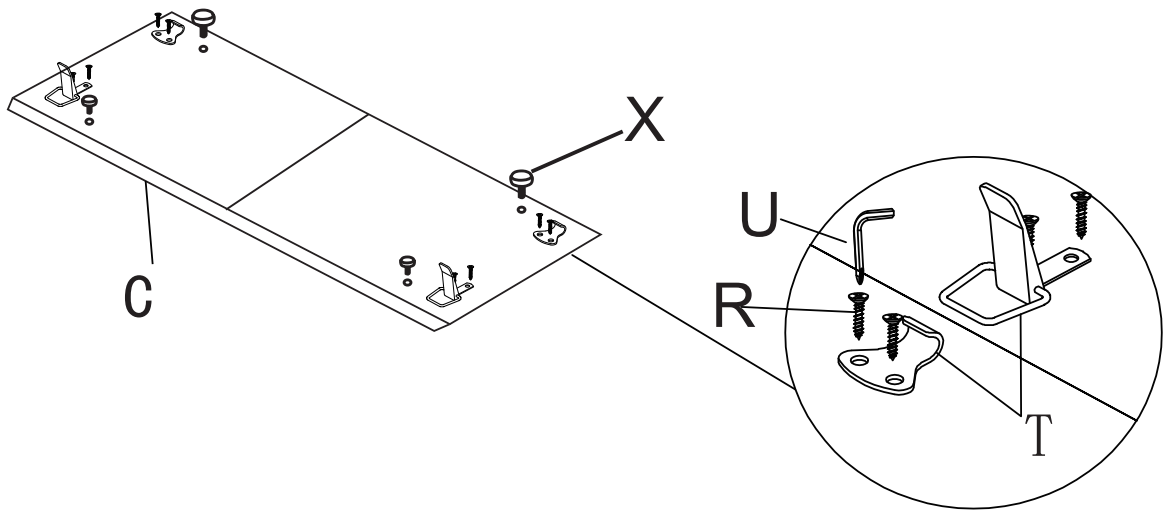
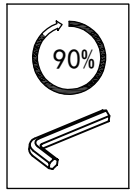

Step 8

Open all pull buttons before
put on the extensible board

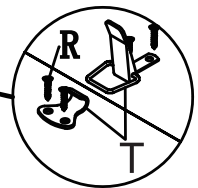
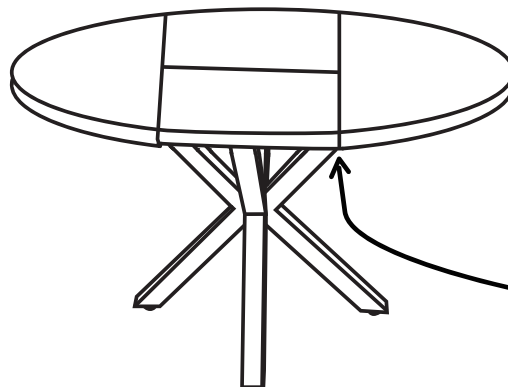
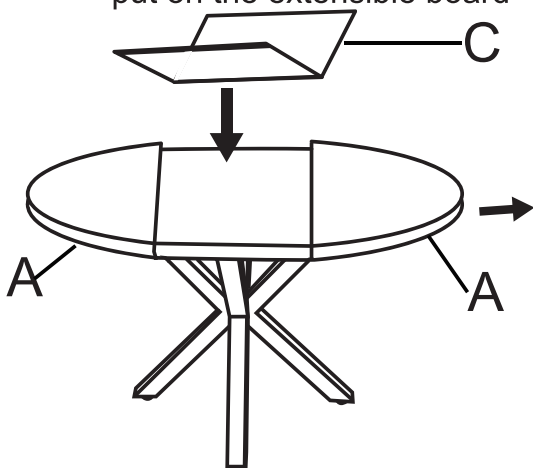

Lock all pull buttons before to use the table

Step 9

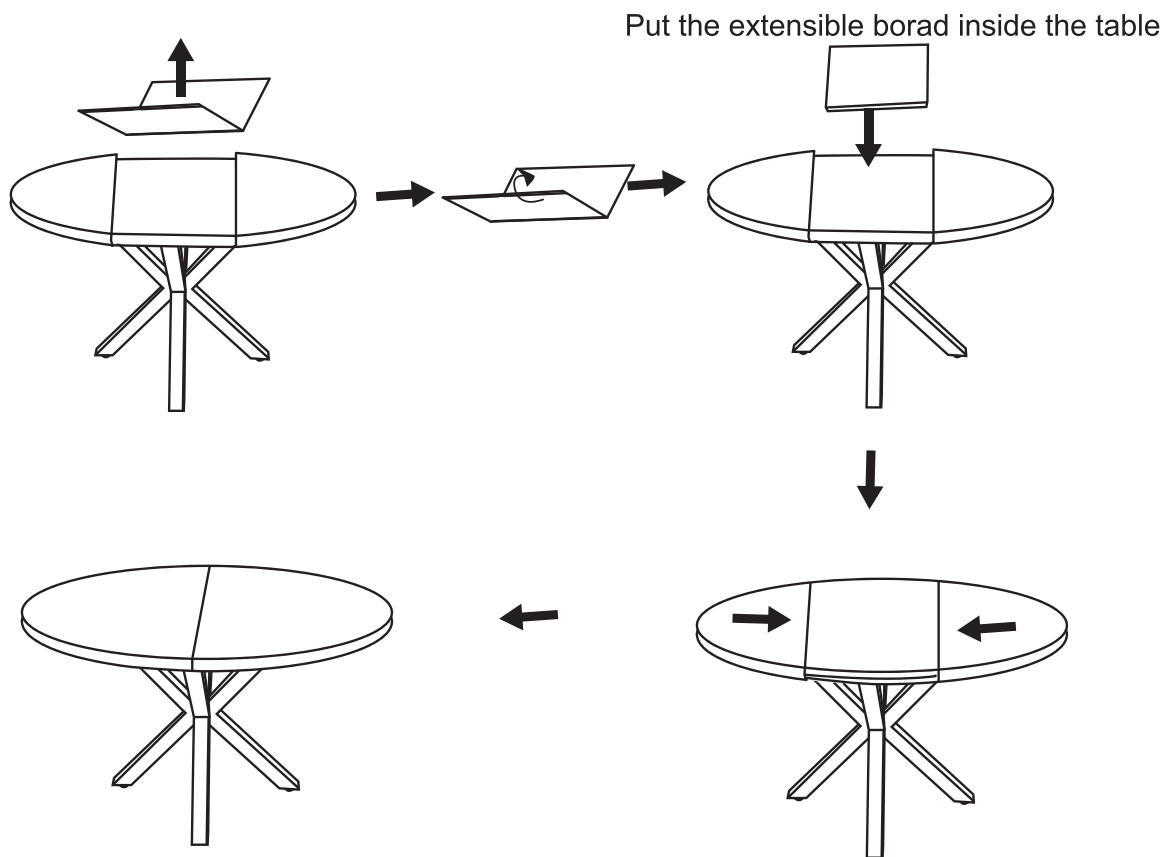

Final Assembly

