

LED Security Area Light

Catalog No. : GRD32-PC-4K-BZ
Type : Wall Mount Area Light
Project Name :
Location :
Qty :
Date :



PROBRITE's Guardian 32-watt outdoor area light, can effectively illuminate large spaces and its photocell technology, making this a true dusk to dawn outdoor light. This powerful LED area light is engineered to offer customers a whole new level of brightness to your outdoor space with 4000K bright white light. Additionally, PROBRITE's Guardian is made of die-cast aluminum and coated with industrial-grade powder coat bronze finish paint which gives durability and reliability to the fixture. The light comes with two mounting options, wall/eave mount using the mounting plate and swivel knuckle flood mount.

PRODUCT PERFORMANCE AT A GLANCE

SYSTEM WATTAGE	LUMENS	LPW	CRI	REPLACES (Incandescent)
32W	4500 lm	140 lm/w	>70	300W



DUSK-TO-DAWN

HOUSING

Die cast aluminum housing with corrosion resistant powder-coated paint finish. It is designed to ensure cooling by natural convection and passive airflow, to let driver perform efficiently

IP RATING & LISTINGS

LED light engine is weather proof and water tight rated as IP65, UL Listed, and DLC premium

OPTICS

Clear polycarbonate lens, does not alter beam and provide focused and clear lighting output.

MOUNTING

It can be mount on wall or eave with plate attached to any junction box. It can be mount on ground as well with 1/2" NPSM pipe thread (Sold separately).

FINISH

Fade, weather, and abrasion resistant, electrostatically applied, thermally cured, triglycidal isocyanurate (TGIC) textured polyester powdercoat bronze paint finish.

WARRANTY

Covered by a 5-year limited warranty. See probrite.com/warranty for details.

PRODUCT SPECIFICATION

Product Dimensions	: 7.54" x 2.62" x 9.07"
Weight	: 3.36 lbs
Lumens	: 4500
LED Wattage	: 32W
Efficacy	: 140W
CRI	: >70
Replaces (Incandescent)	: 300W
Mounting	: Wall Mount/Eave Mount
Frequency	: 50-60Hz
THD (Total Harmonic Distortion)	: <20%
PF(Power Factor)	: >0.9
Ambient Operating Temperature	: (-30)-40°C
Input Voltage	: 120-277V
LED Chip	: -
Photocell	: Yes
Driver	: Dimming
Standard Lifetime	: 50,000 hrs
Standard Warranty	: 5 Years
Water Proofing Grade	: Suitable for wet location
CCT	: 4000K Bright White Light
Certifications	: IP65, FCC Certified, UL Certified, DLC Premium

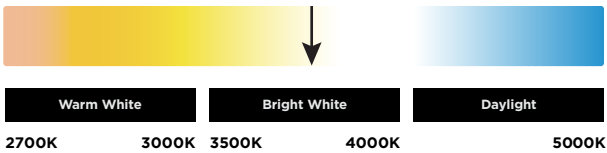

SUGGESTED MOUNTING HEIGHT:
6-12 FT.(1.8-3.7 M)

3D PHOTOMETRIC VIEW

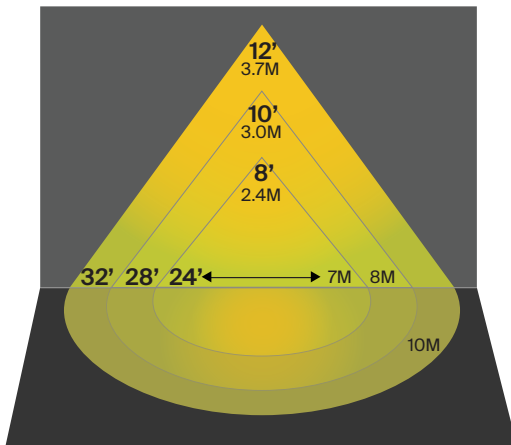

PRODUCT LINE DRAWING

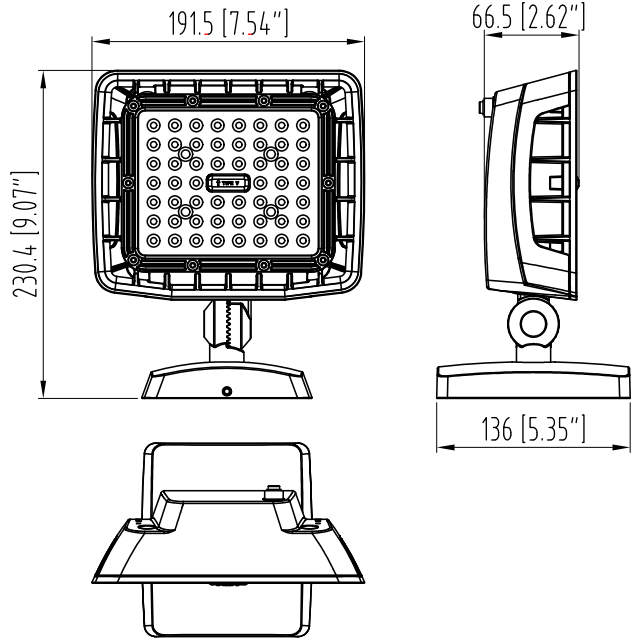

APPLICATION

SUITABLE FOR MULTIPLE APPLICATIONS

WAREHOUSES • LOADING BAYS • PATIOS
• COMMERCIAL PARKS • APARTMENT COMPLEXES

