

ASSEMBLY INSTRUCTIONS



CAUTION

◆ Inspect the wire insulation for any cuts, abrasions, or exposed copper that may have resulted during shipping. If there is a defect in the wire, do not attempt installation.

◆ Before starting installation of this fixture or removal of a previous fixture, disconnect the power by turning off the circuit breaker or by removing the fuse at the fuse box.

TOOLS REQUIRED



Ladder



Safety Goggles



Electrical Tape



Phillips Screwdriver



Flathead Screwdriver



Wire Cutter



Wire Stripper

HARDWARE INCLUDED

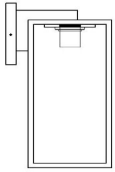

Fixture



Mounting Unit

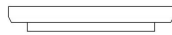

Socket Ring

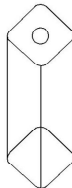

Glass shade



Spanner



Screws



Mounting Screws



Wire Nuts

***PARTS SHOWN MAY DIFFER SLIGHTLY PER LIGHT FIXTURE**

EXPLODED PARTS

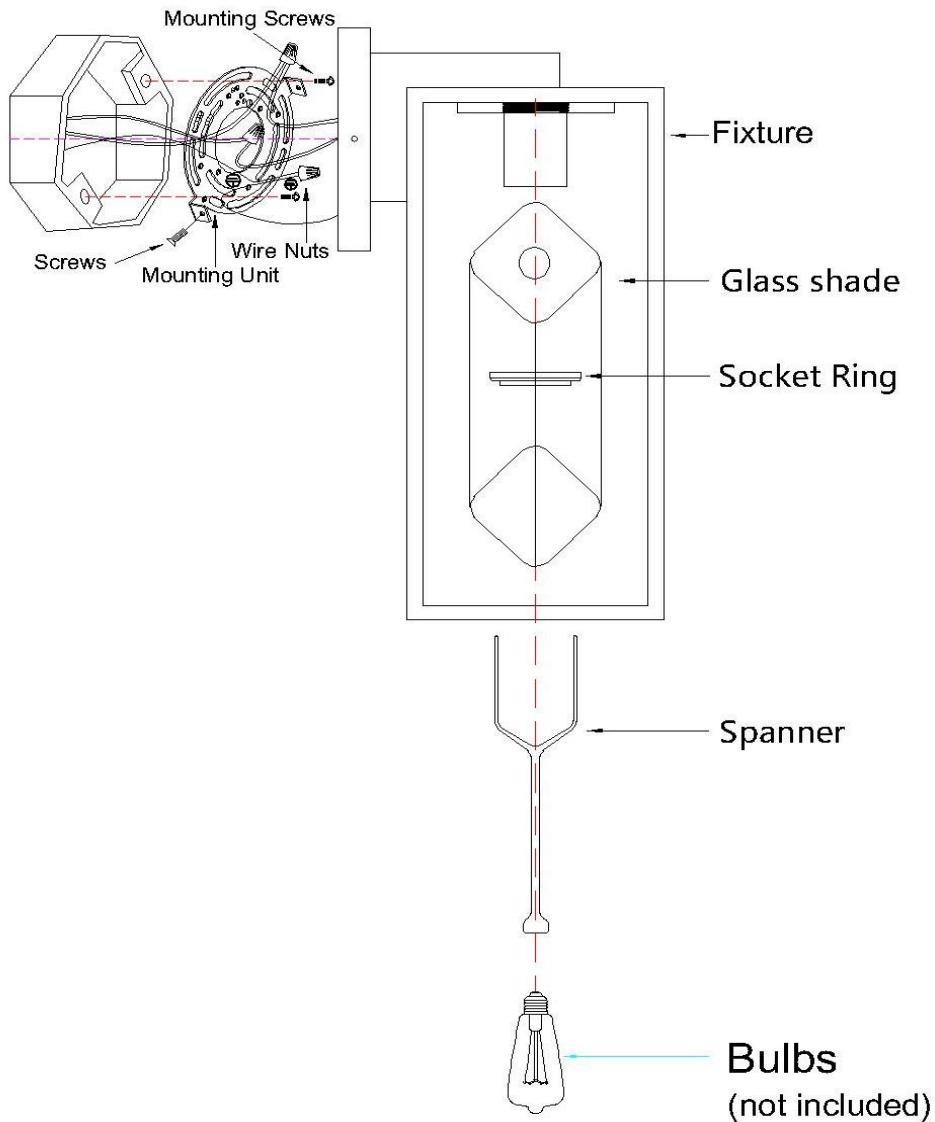

STEP 1

Unscrew the Screws 1 from the mounting unit.
Use the mounting screws to attach the mounting unit to the junction box.

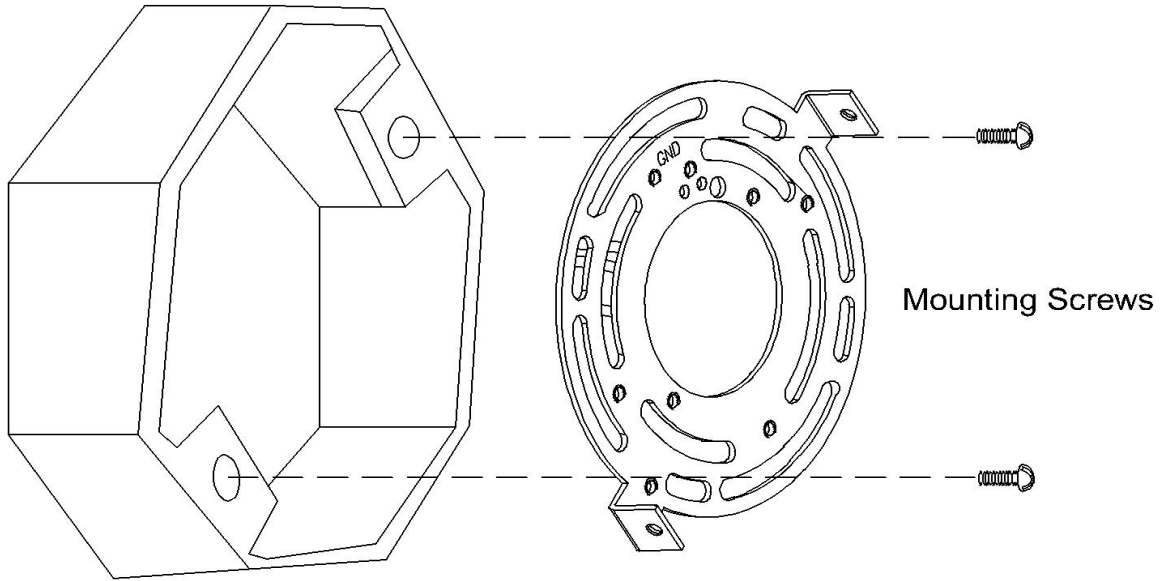

STEP 2

Make the electrical connection from the junction box to the fixture
Connect the ground wire to the mounting unit using the preinstalled green ground screw
Then, connect the positive, negative and ground wires with the supplied wire nuts,
Secure with electrical tape

