

CollaredEagle

Dressing table

VD008

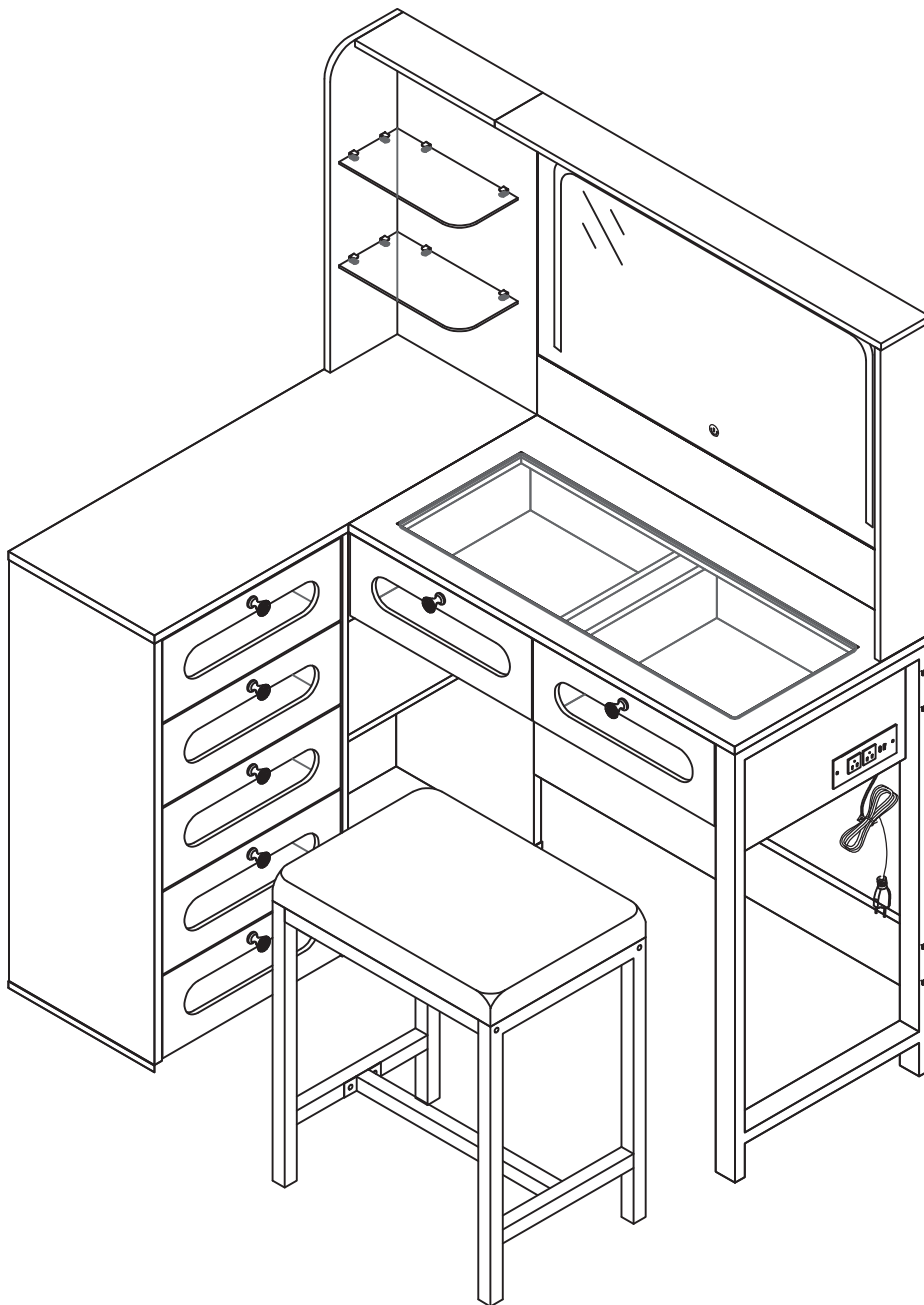

Suggestion: To make the installation process easier and faster, we recommend that two people work together to install the Dressing table.

Helpful Hints

1. We recommend two people to assemble the product easier and faster.
2. Please DO NOT tighten the screws deeply during assembling avoiding that metal frame can be bent and plank will crack.
3. We recommend that all screws should not be tightened over during assembling to make it easy to adjust. When it is adjusted to proper station all screws should be tightened.
4. Caution: If using a power drill or power screwdriver for screwing, please be aware of to slow down and stop when screw is tight. Failure to do so may result in stripping the screw.

Customer Service

As this item contains many parts, please read the installation instruction carefully before installation and complete the installation with the cooperation of your partner. Please use tools properly and carefully. If you have any questions about the product and installation, please contact us freely.  **CollaredEagle@163.com**

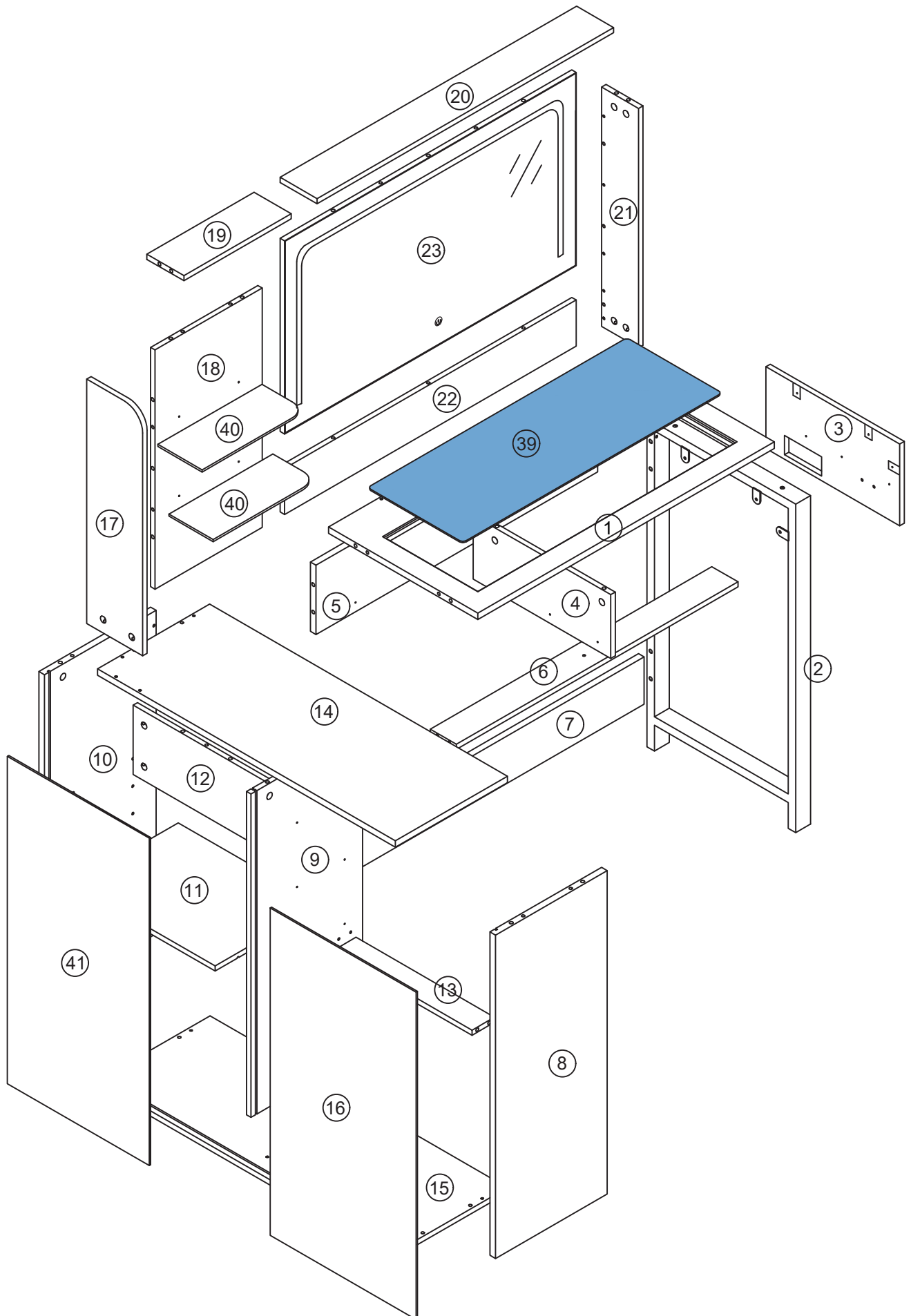

EXPLODED

INSTALLATION INSTRUCTIONS

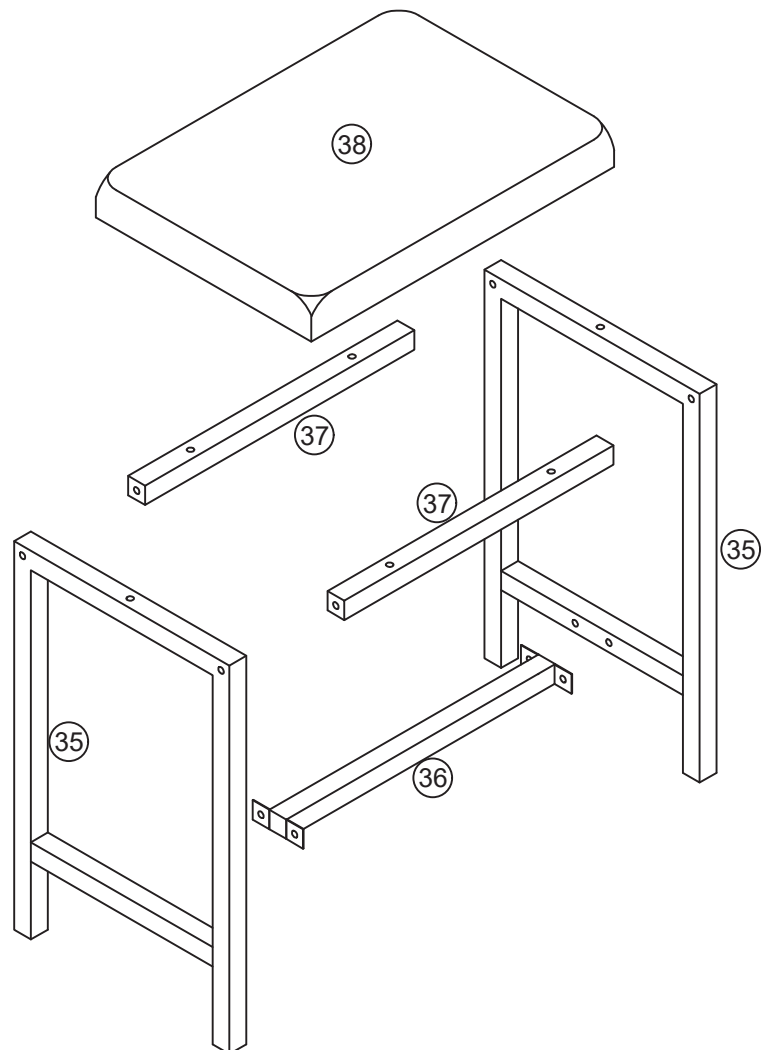
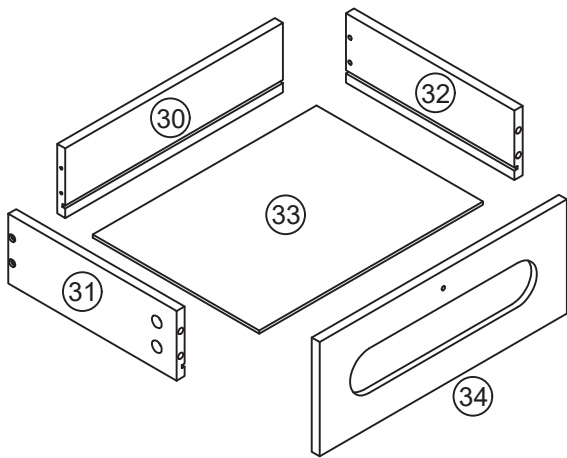
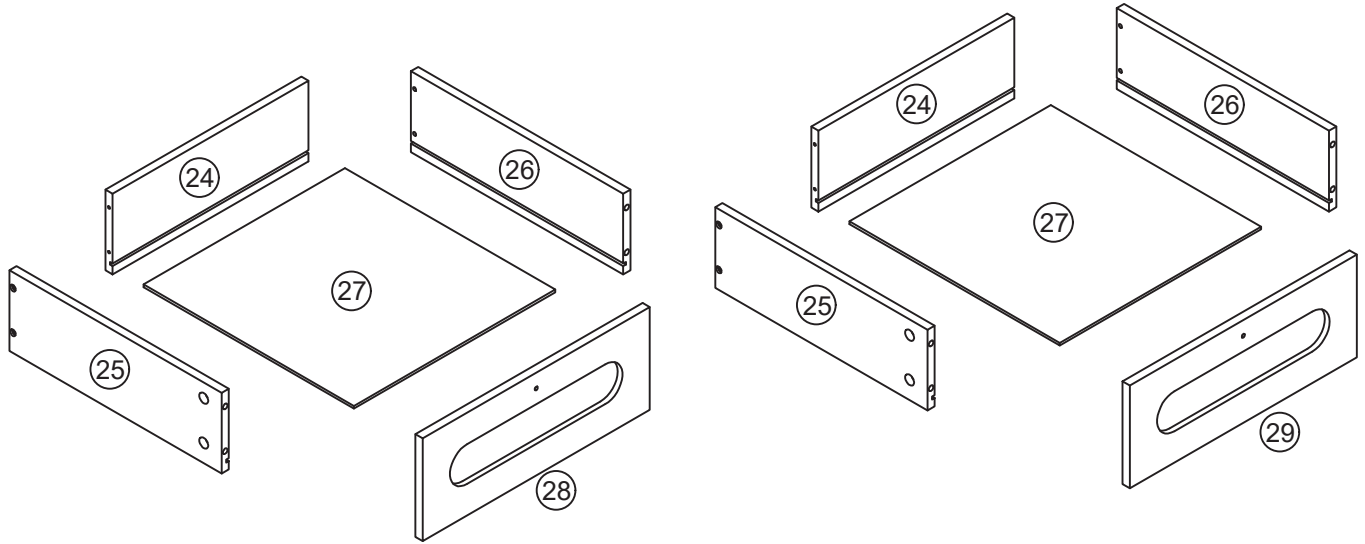

Accessories list

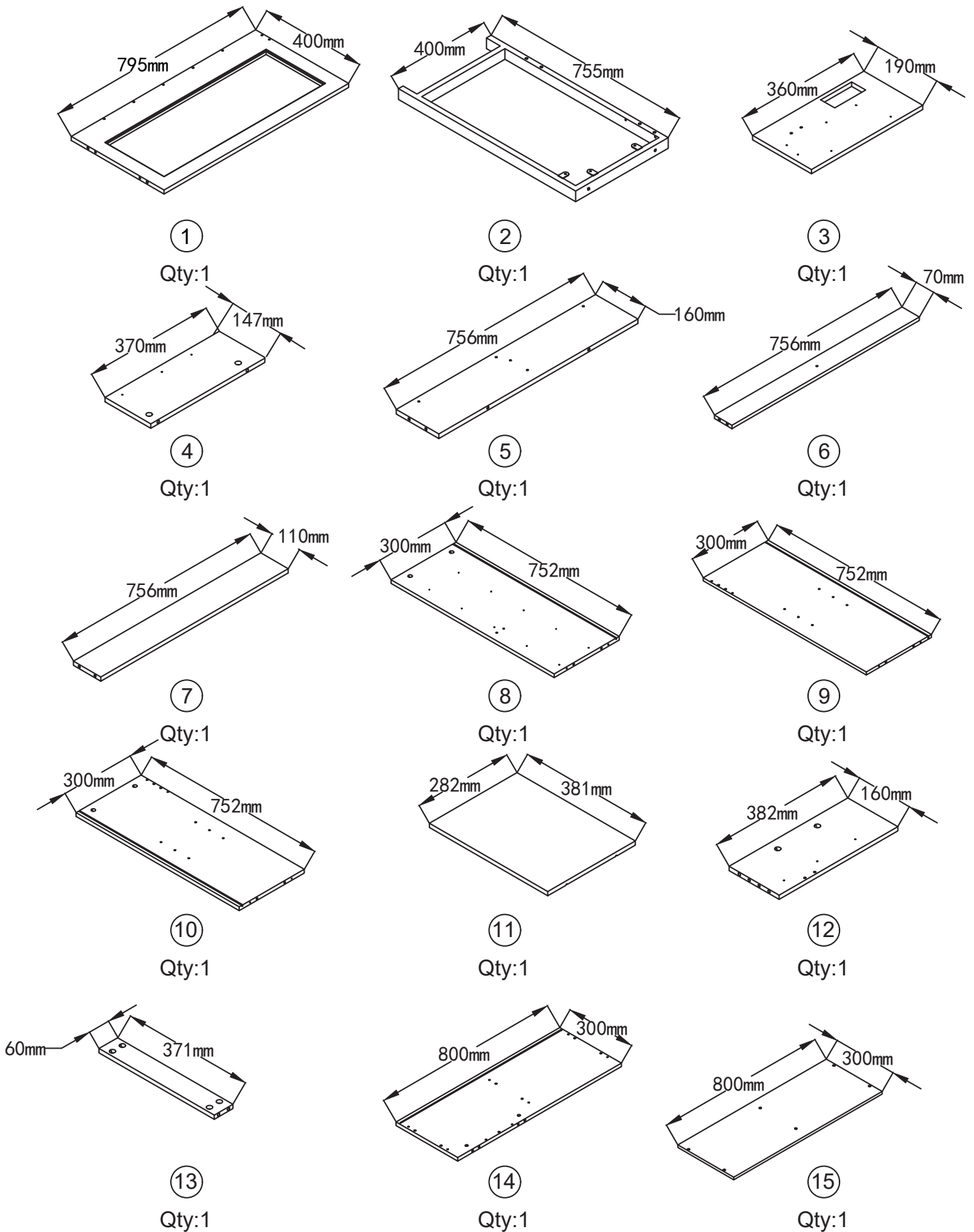

In many cases, we include additional hardware. Therefore, after following the assembly instructions, do not worry if there are any extra parts - they are provided as a precautionary measure for convenience.

Accessories list

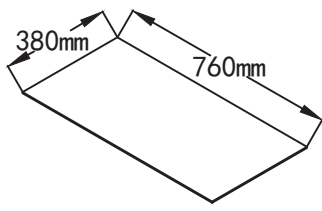

16

Qty: 1

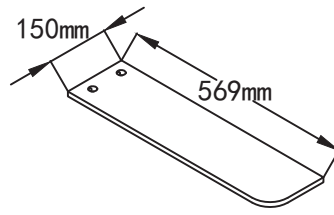

17

Qty: 1

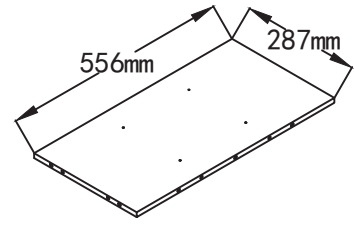

18

Qty: 1

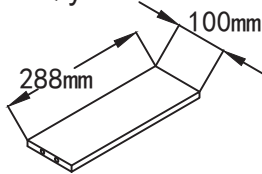

19

Qty: 1

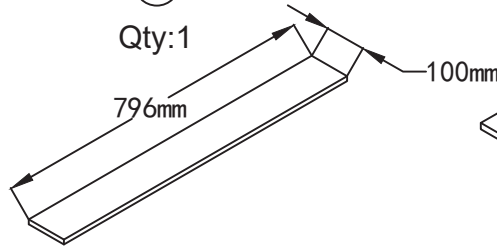

20

Qty: 1

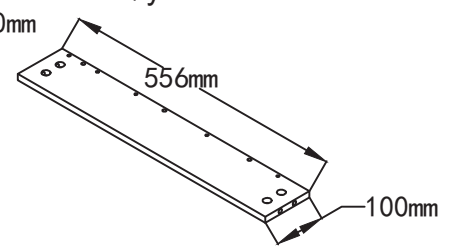

21

Qty: 1

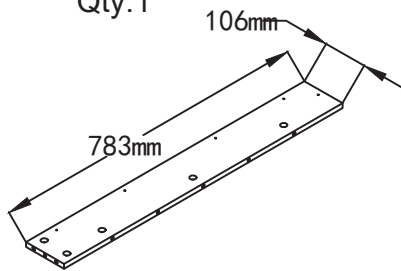

22

Qty: 1

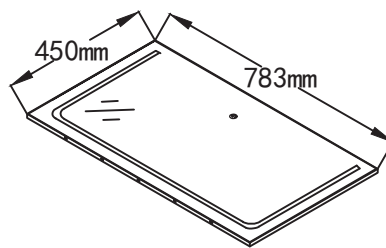

23

Qty: 1

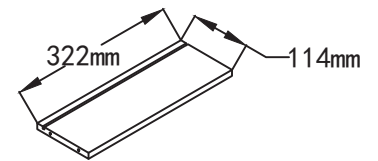

24

Qty: 2

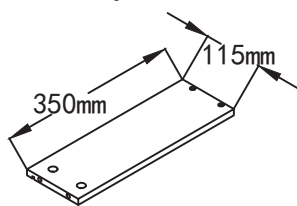

25

Qty: 2

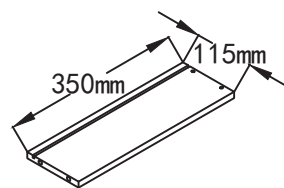

26

Qty: 2

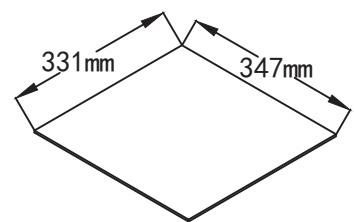

27

Qty: 2

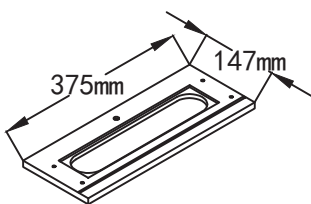

28

Qty: 1

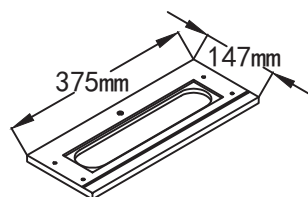

29

Qty: 1

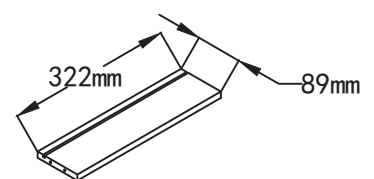

30

Qty: 5

In many cases, we include additional hardware. Therefore, after following the assembly instructions, do not worry if there are any extra parts - they are provided as a precautionary measure for convenience.

Accessories list

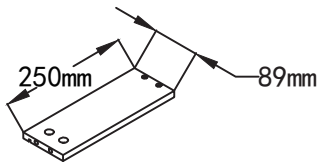

31

Qty:5

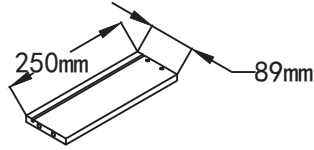

32

Qty:5

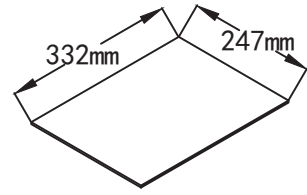

33

Qty:5

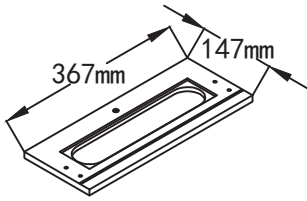

34

Qty:5

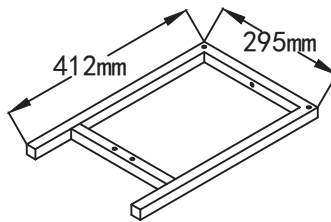

35

Qty:2

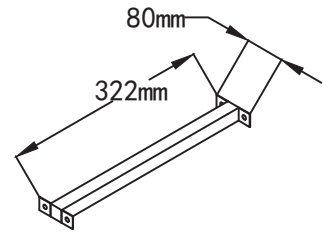

36

Qty:1

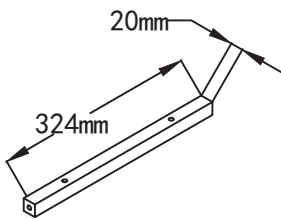

37

Qty:2

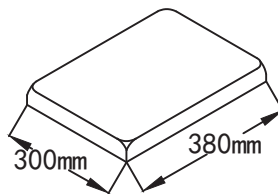

38

Qty:1

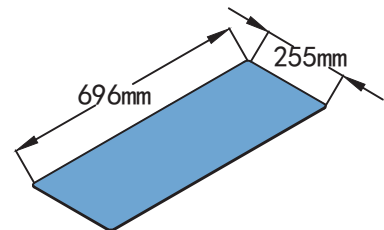

39

Qty:1

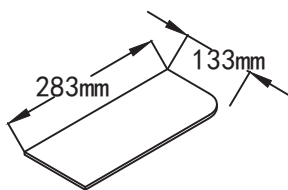

40

Qty:2

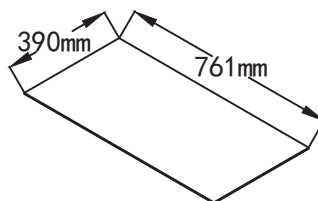









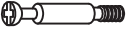















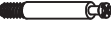





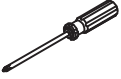

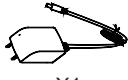

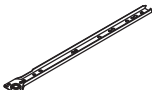
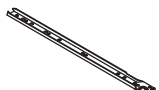
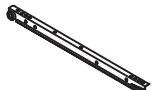

41

Qty:1

In many cases, we include additional hardware. Therefore, after following the assembly instructions, do not worry if there are any extra parts - they are provided as a precautionary measure for convenience.

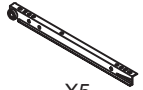
Accessories list

 X78+2 (A) M6.5X35mm	 X84+2 (B) Ø15X9.5mm	 X35+2 (C) M6X30mm	 X37+2 (D) M4X40mm	 X1 (E)
 X84+1 (F) M3.5X12mm	 X1 (G)	 X3 (H)	 X5 (I) M4X12mm	 X12+1 (J)
 X12+1 (K) M3X14mm	 X10 (L)	 X4 (M) M6X80mm	 X4 (N) M6X15mm	 X8 (O) M6X30mm
 X4 (P) M6X40mm	 X1 (Q) M4mm	 X6 (R) M6.5X60mm	 X6 (S)	 X9+1 (T)
 X1 (U)	 X4 (V)	 X8+1 (W) Ø20mm	 X1 (X)	 X8 (Y)
 X1 (Z)	 X8 (a) M3X12mm	 X7 (b)	 X7 (c)	 X2 (d) M4X40mm
 X2 (e)	 X2 (CL) 350mm	 X2 (CR) 350mm	 X2 (DR) 350mm	 X2 (DL) 350mm
 X5 (CL) 250mm	 X5 (CR) 250mm	 X5 (DR) 250mm	 X5 (DL) 250mm	

In many cases, we include additional hardware. Therefore, after following the assembly instructions, do not worry if there are any extra parts - they are provided as a precautionary measure for convenience.

step 1

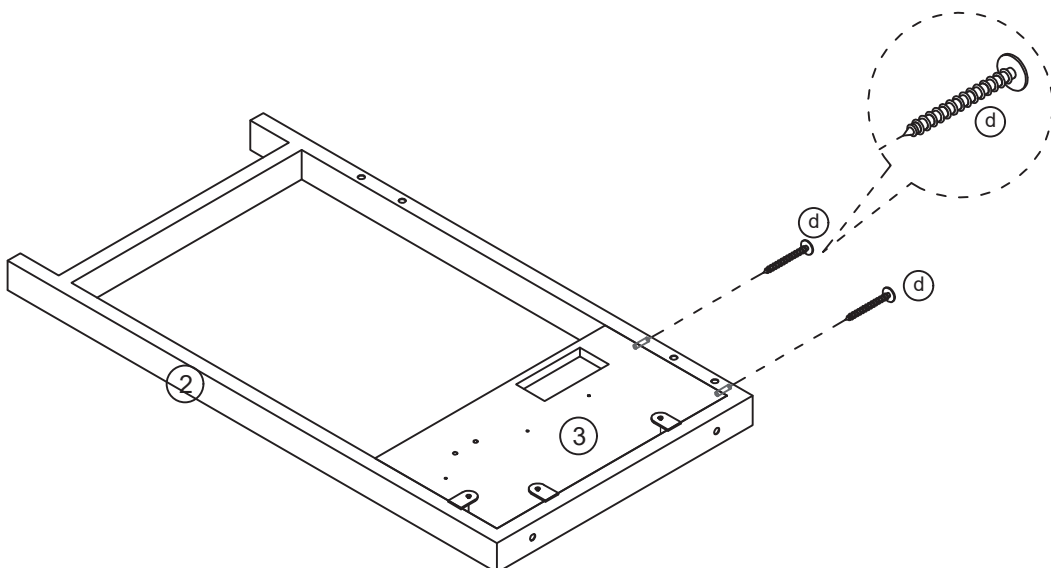
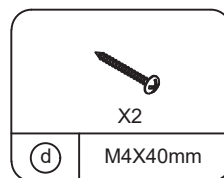
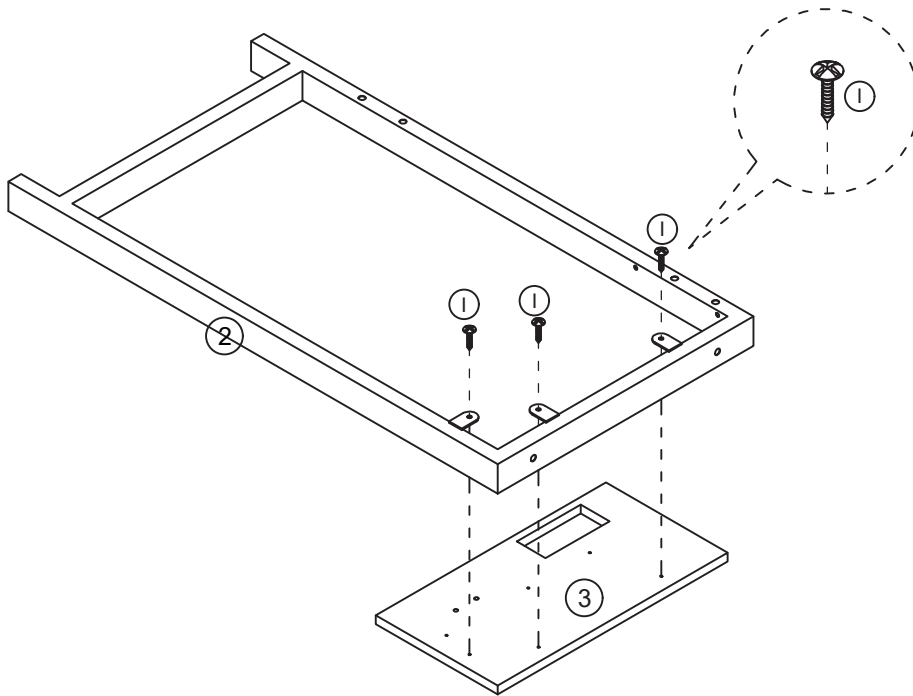
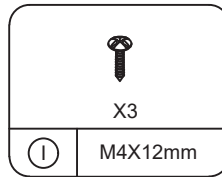

step 2

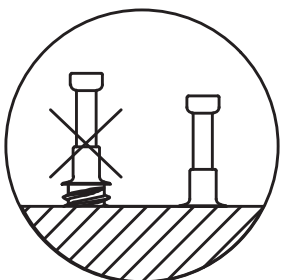
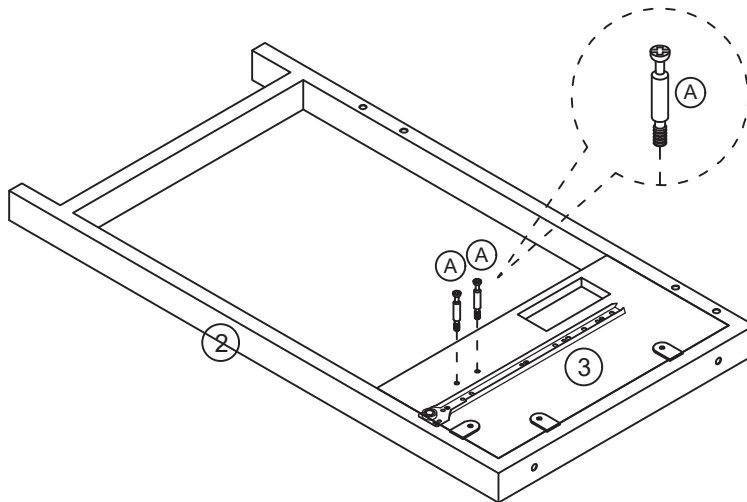
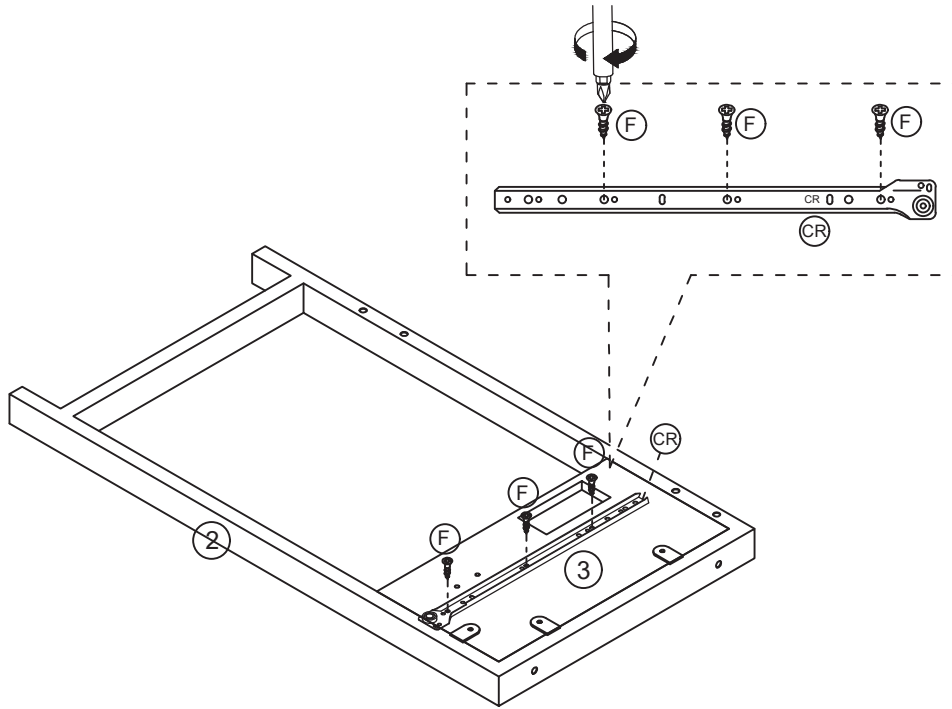
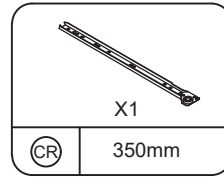
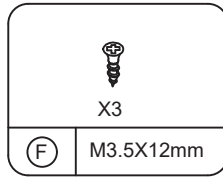
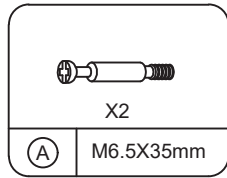

step 3

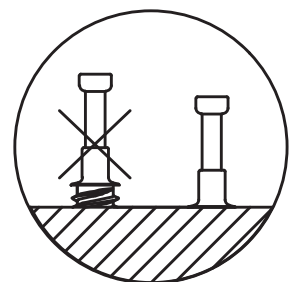
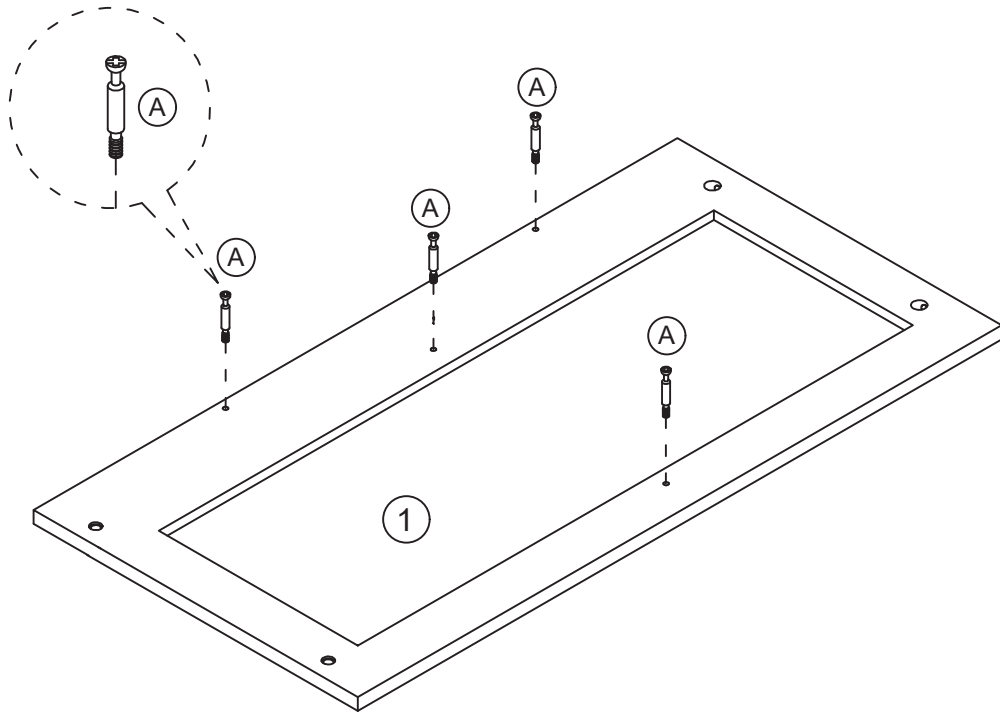
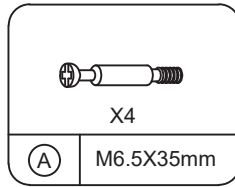

step 4

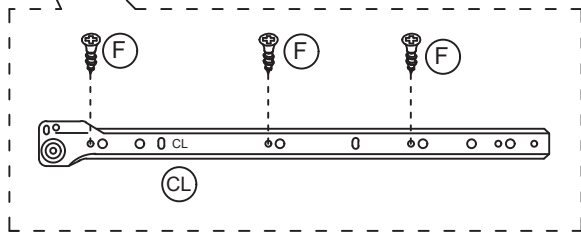
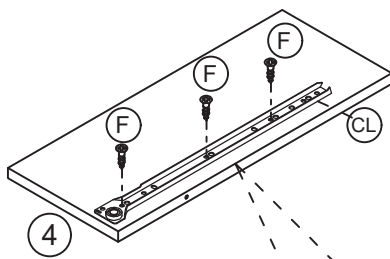
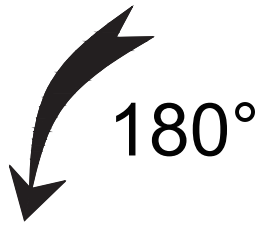
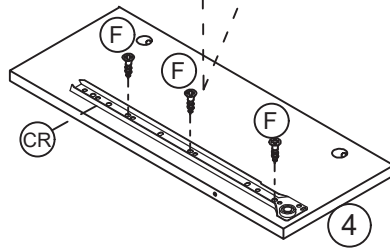
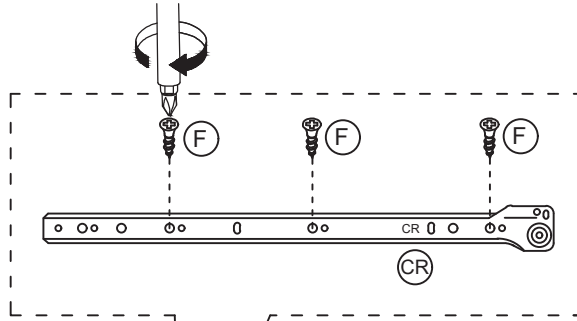
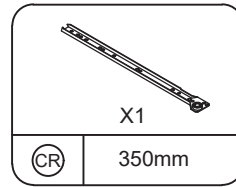
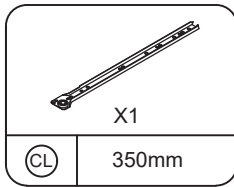
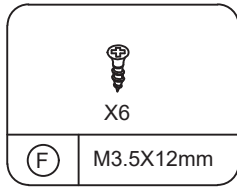

step 5

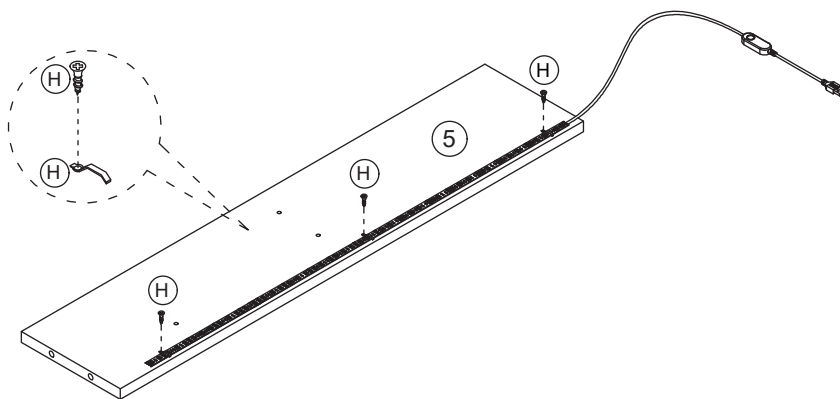
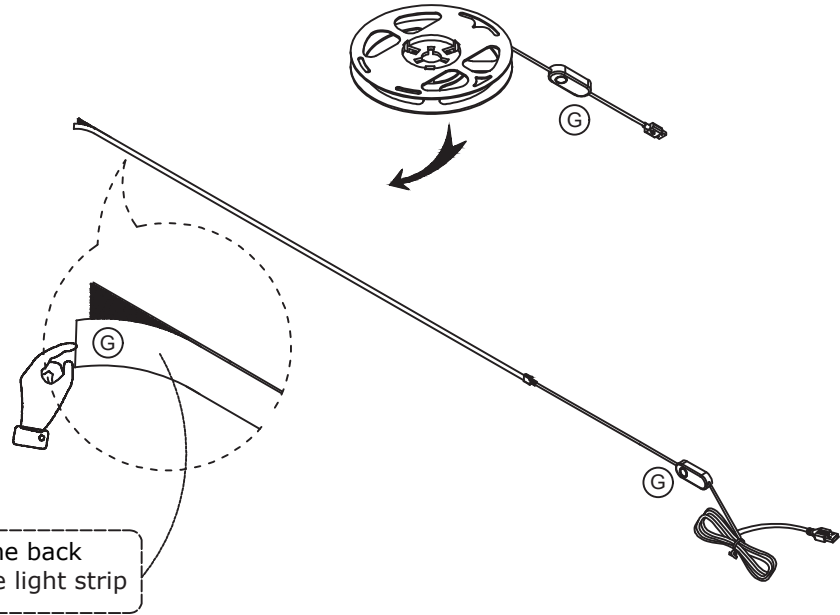
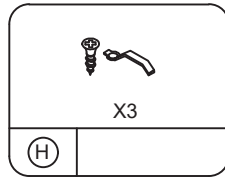
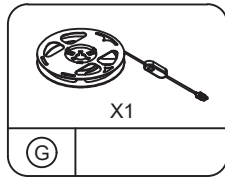

step 6

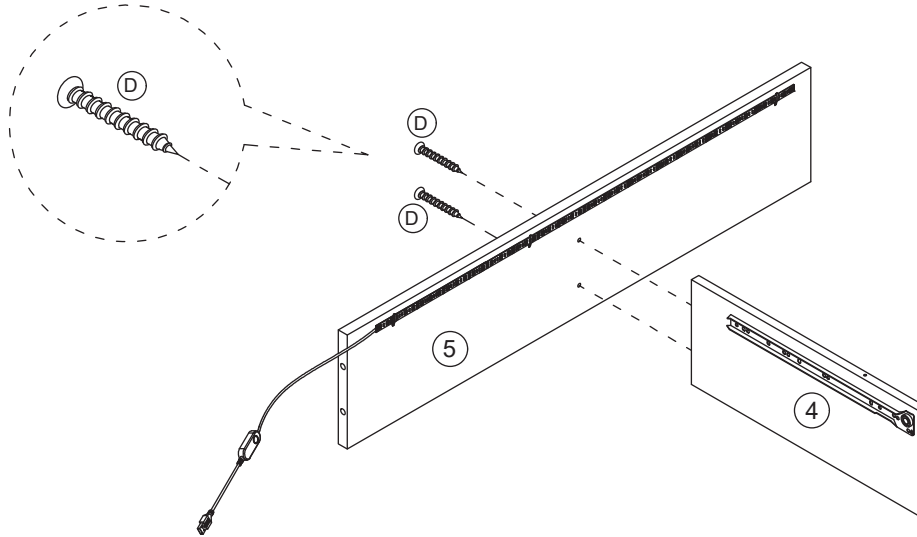
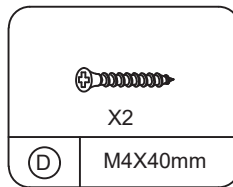

step 7

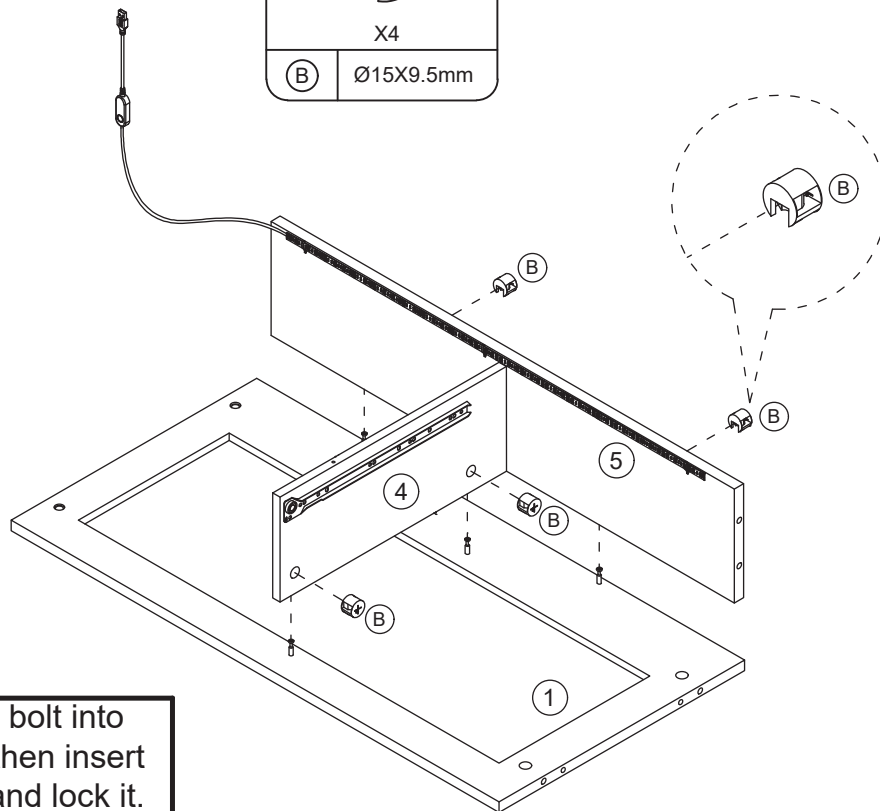
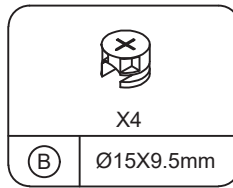

Insert the cam bolt into the hole first, then insert the cam lock and lock it.

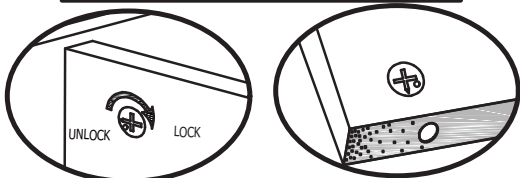

Proper orientation of CAM LOCK

step 8

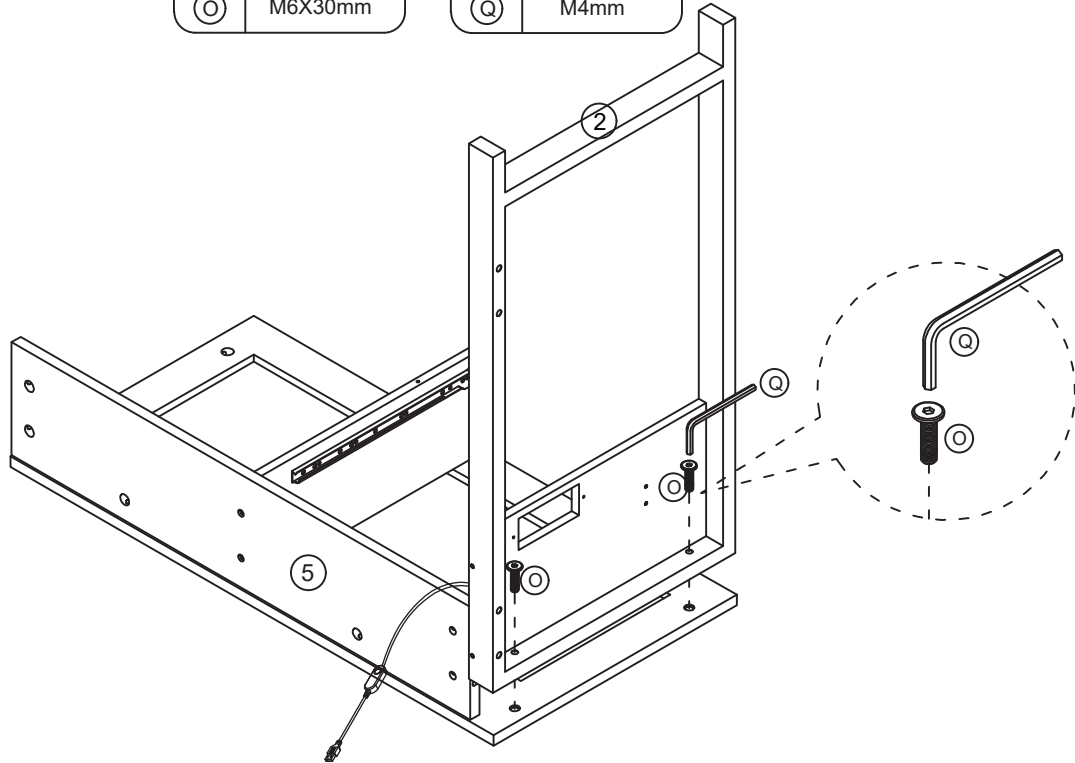
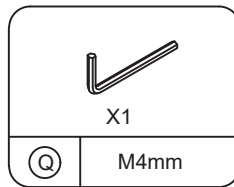
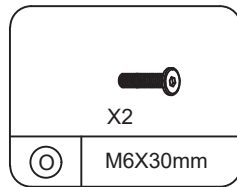

step 9

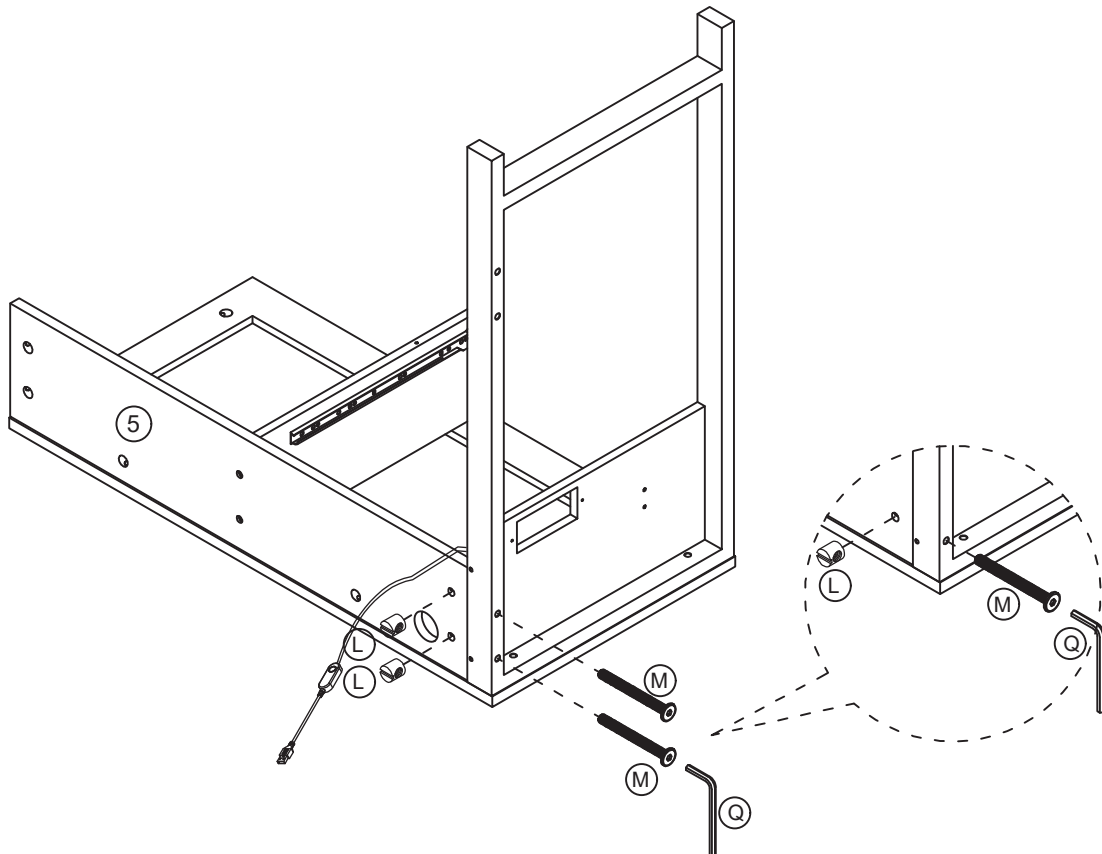
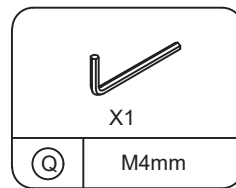
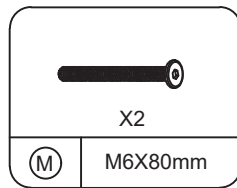
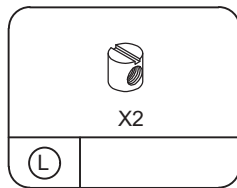

step 10

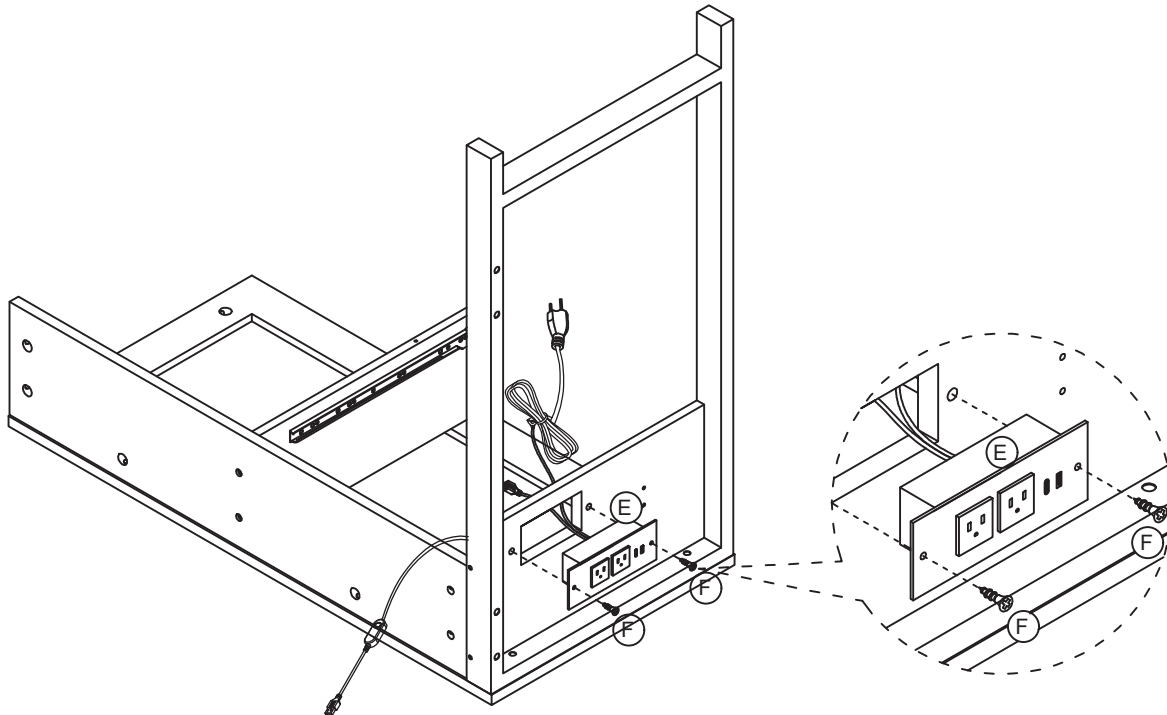
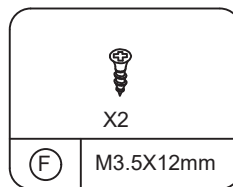
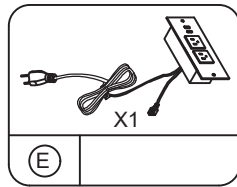

step 11

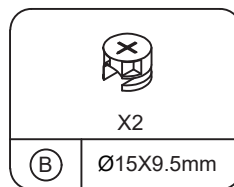

Insert the cam bolt into the hole first, then insert the cam lock and lock it.

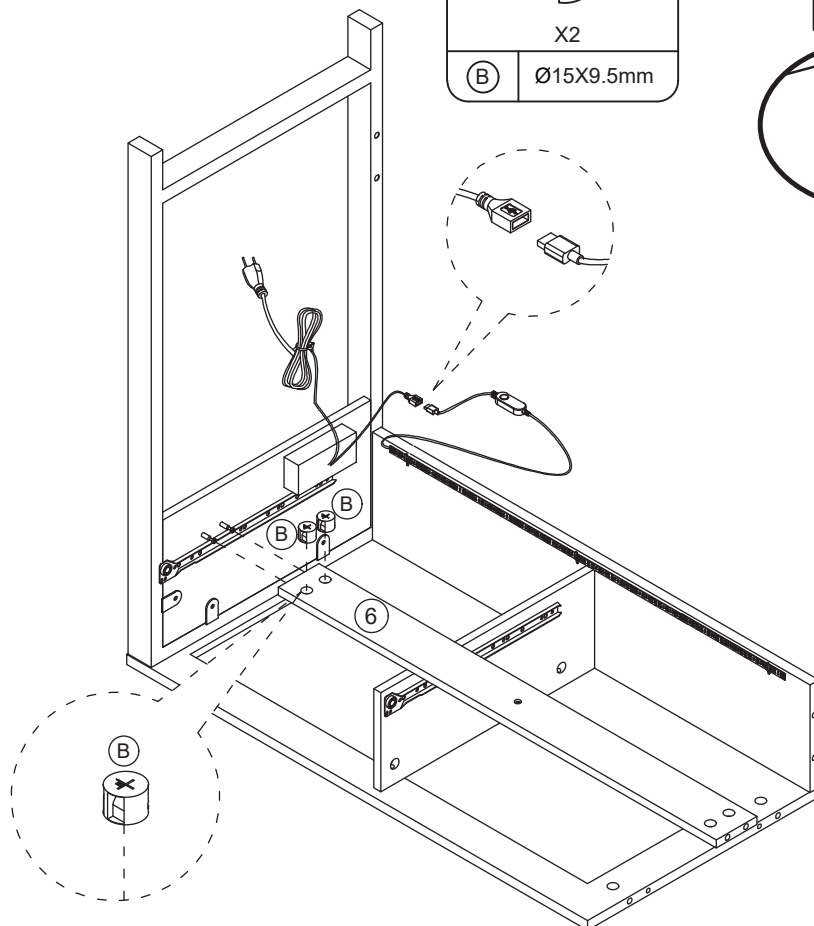
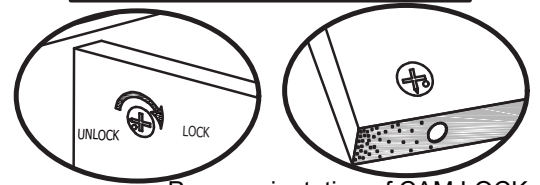

step 12

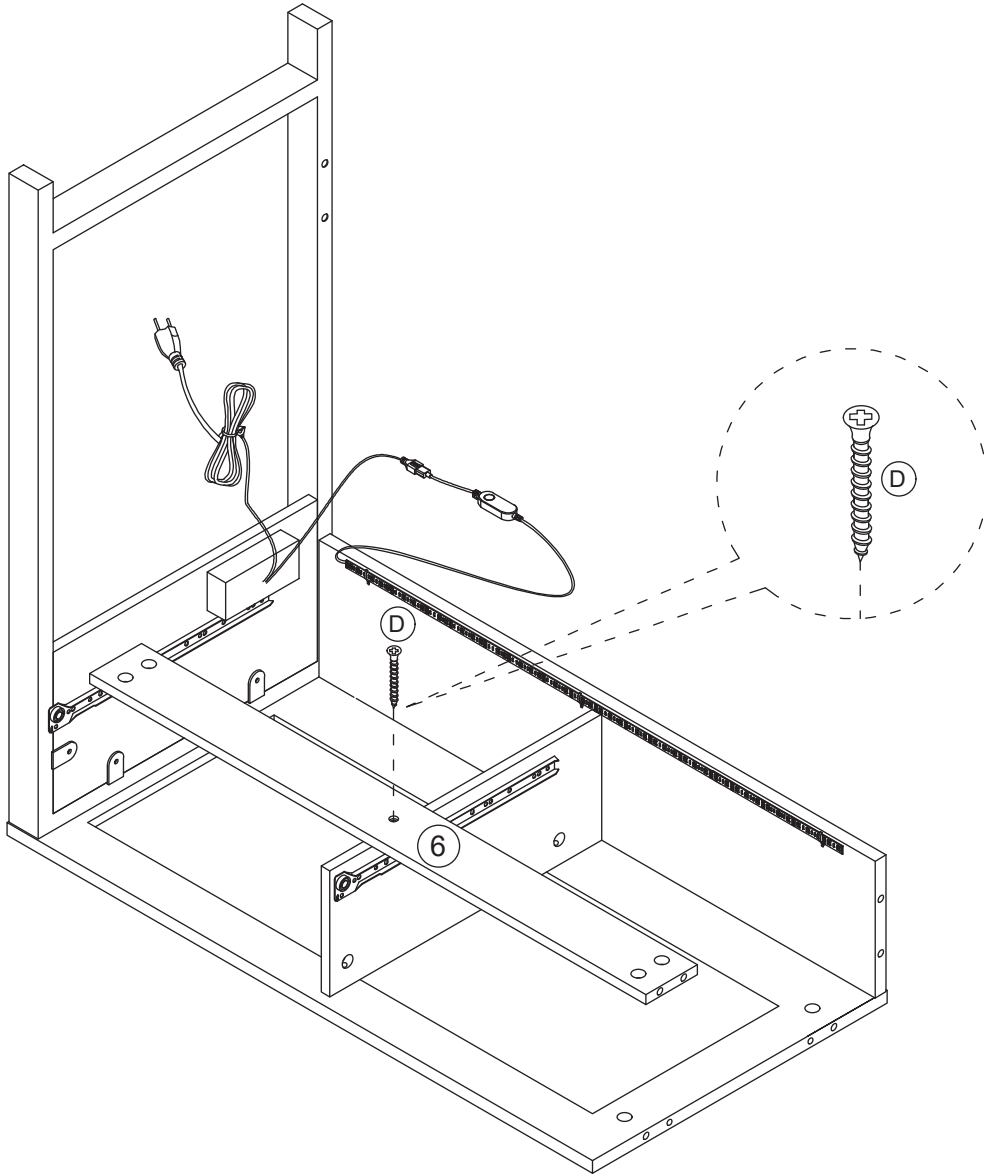
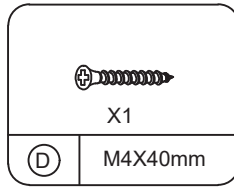

step 13

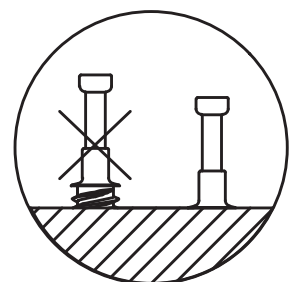
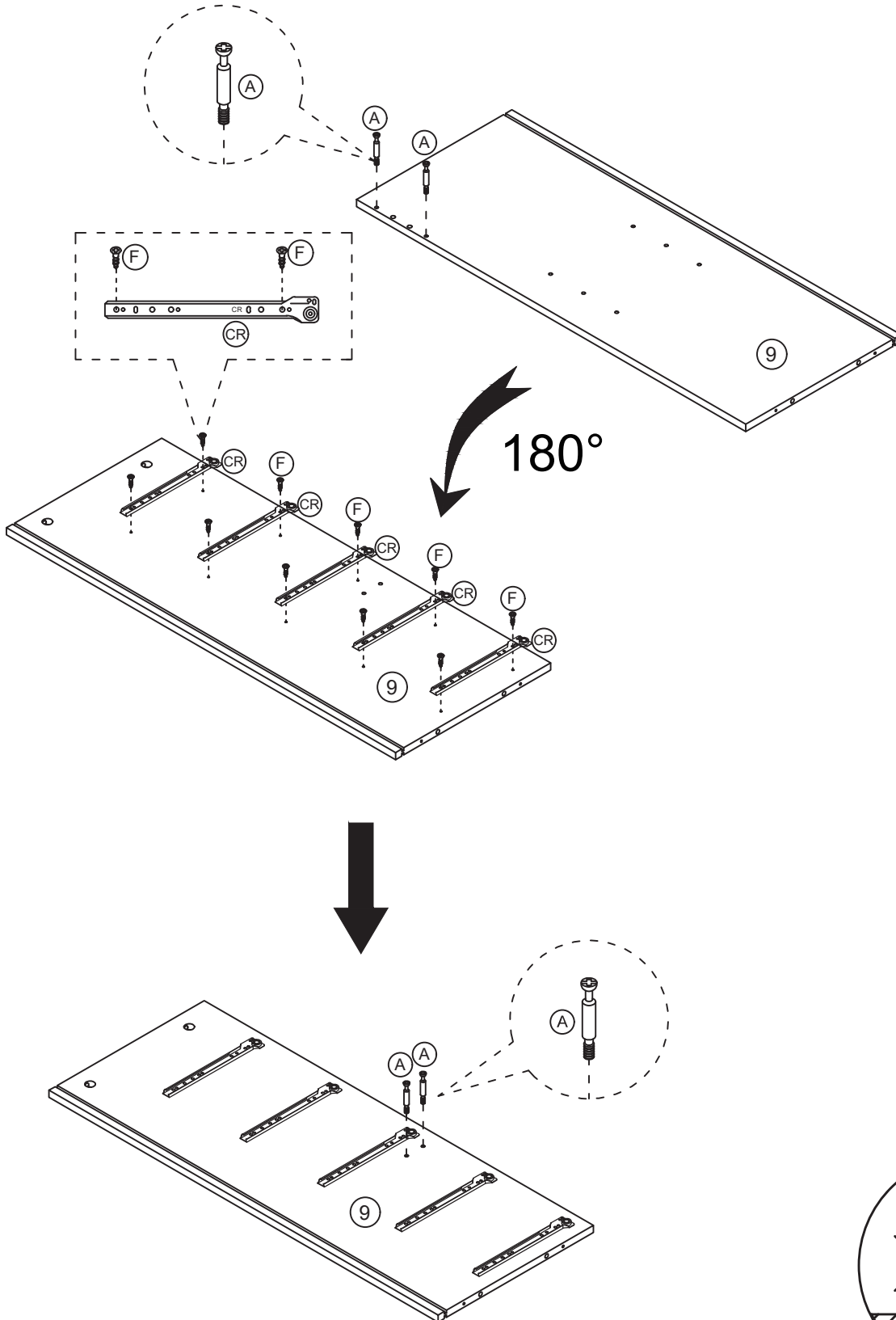
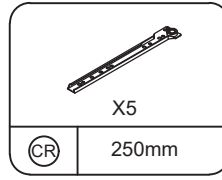
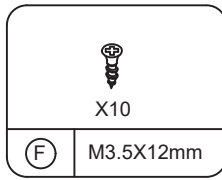
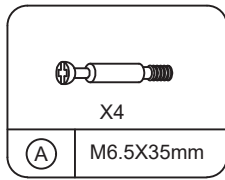

step 14



X2	
(A)	M6.5X35mm

X4	
(L)	

X4	
(R)	M6.5X60mm

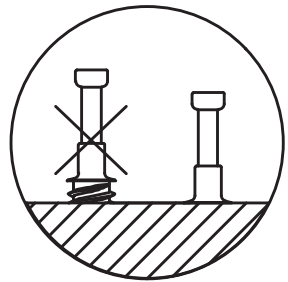
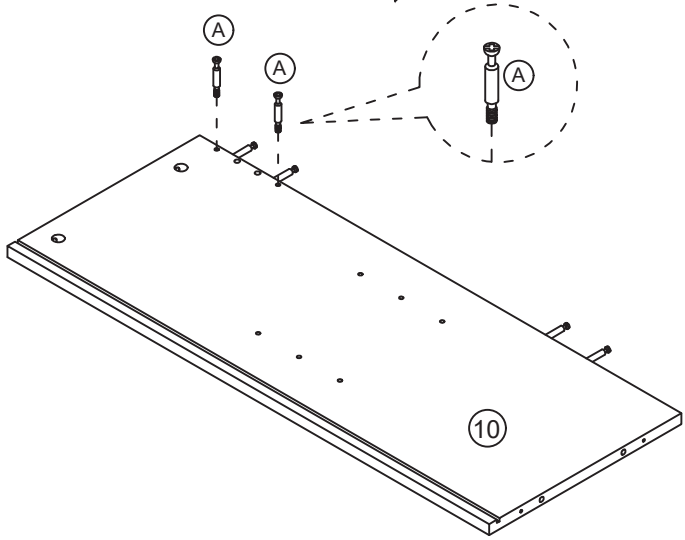
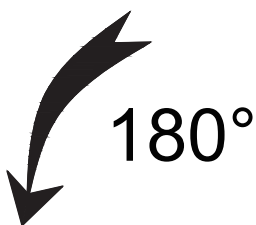
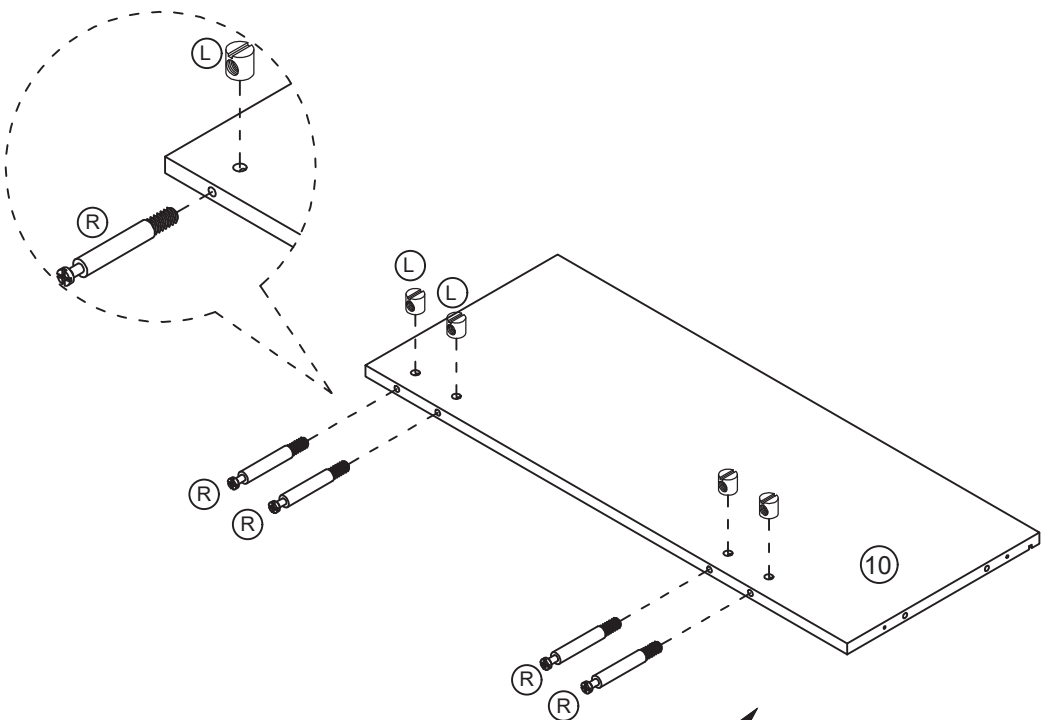

step 15

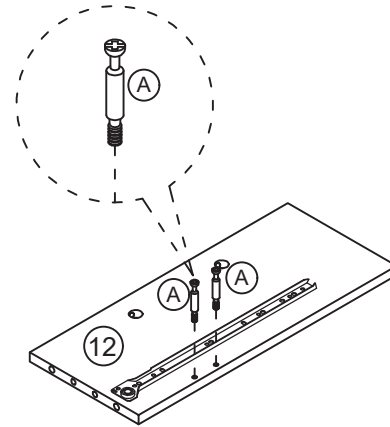
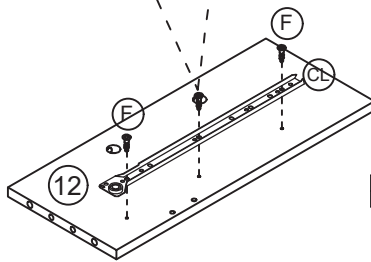
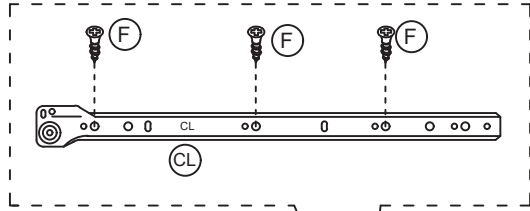
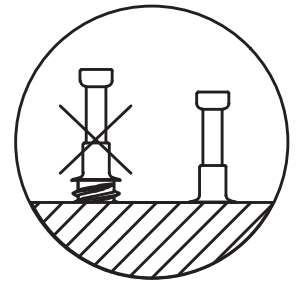
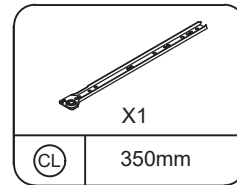
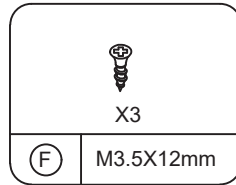
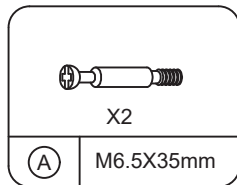

step 16

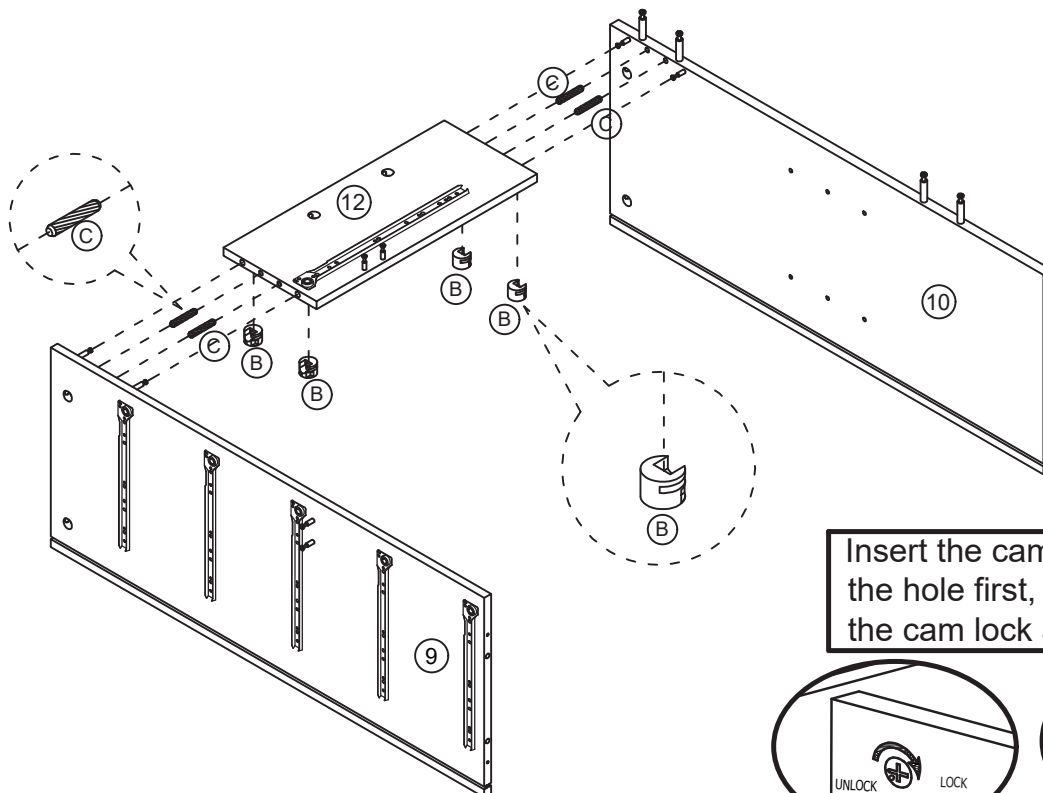
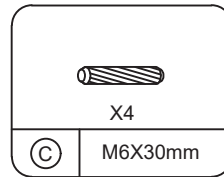
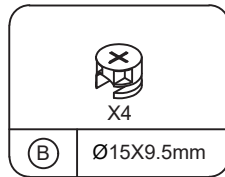

Insert the cam bolt into the hole first, then insert the cam lock and lock it.

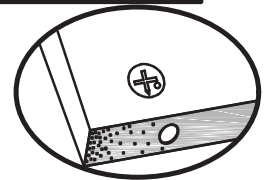

Proper orientation of CAM LOCK

step 17

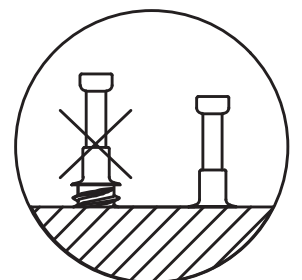
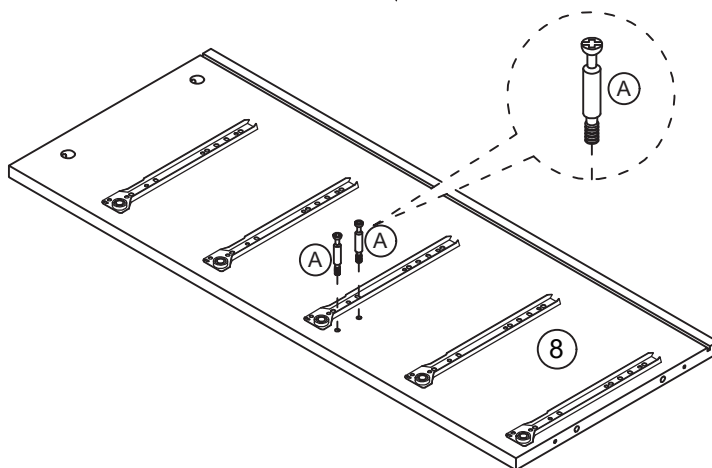
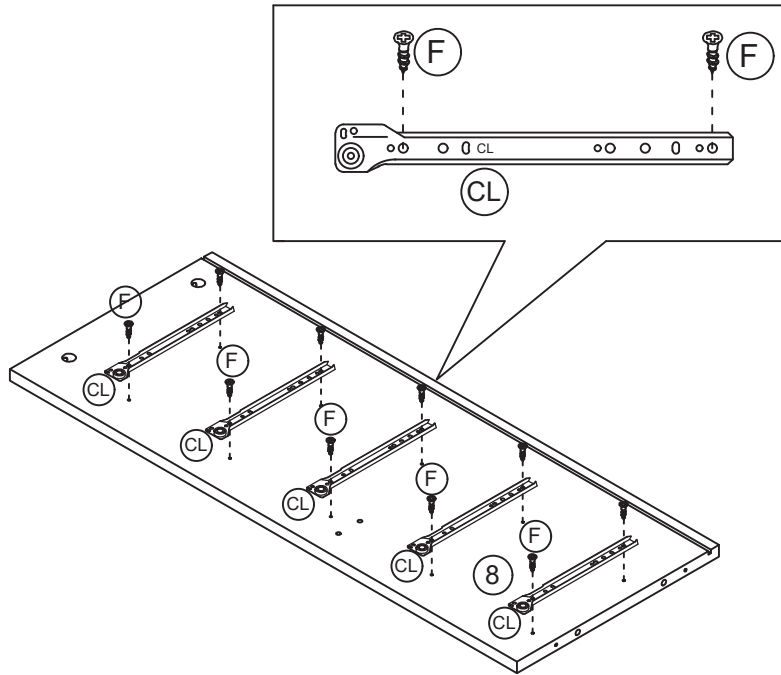
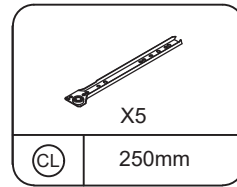
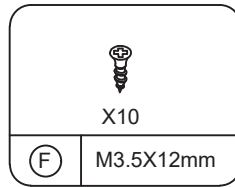
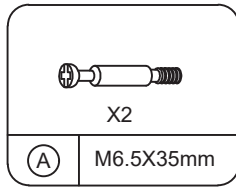

step 18

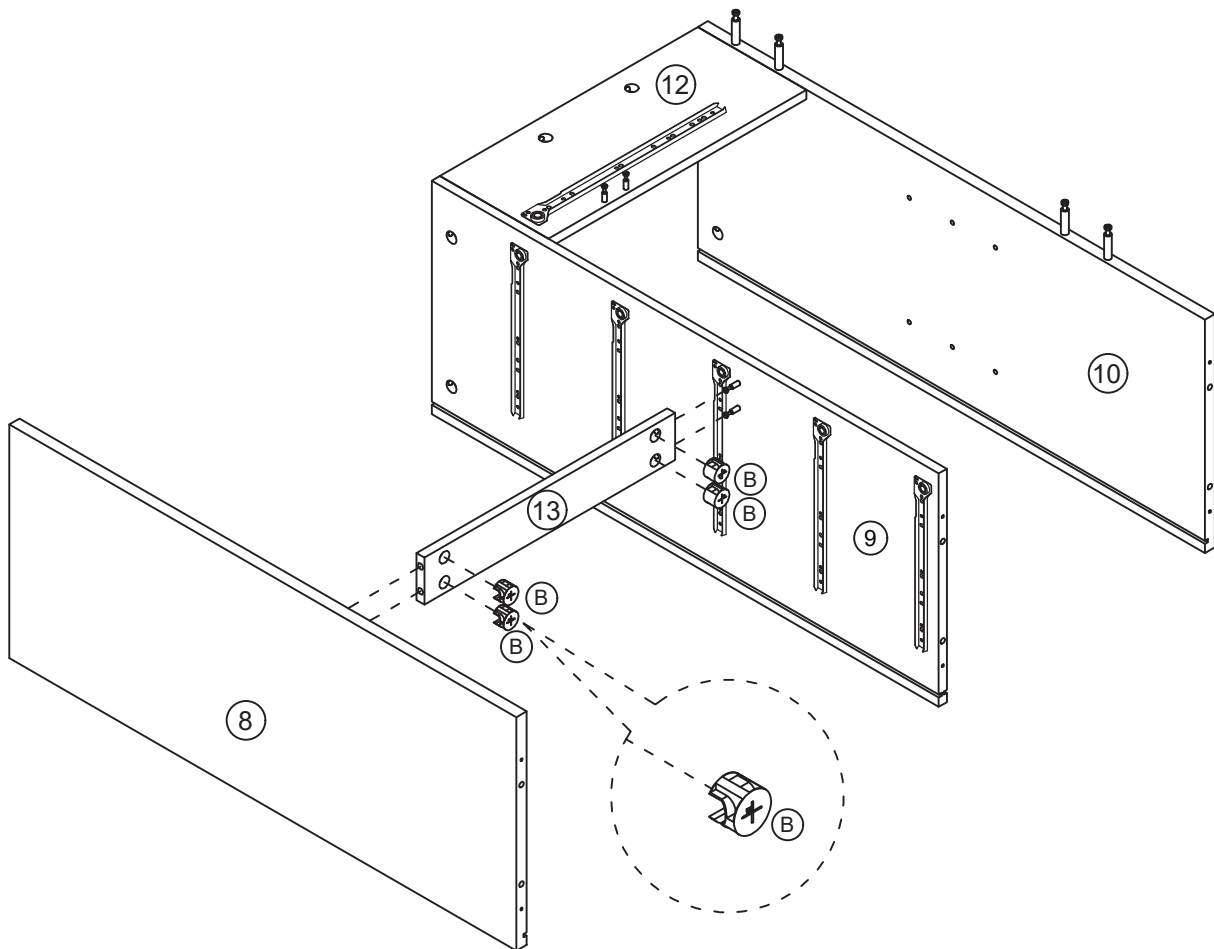
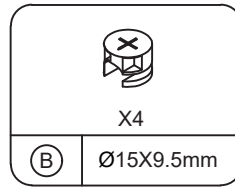

Insert the cam bolt into the hole first, then insert the cam lock and lock it.

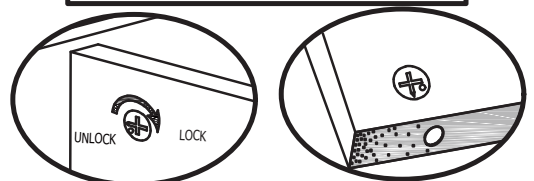

Proper orientation of CAM LOCK

step 19

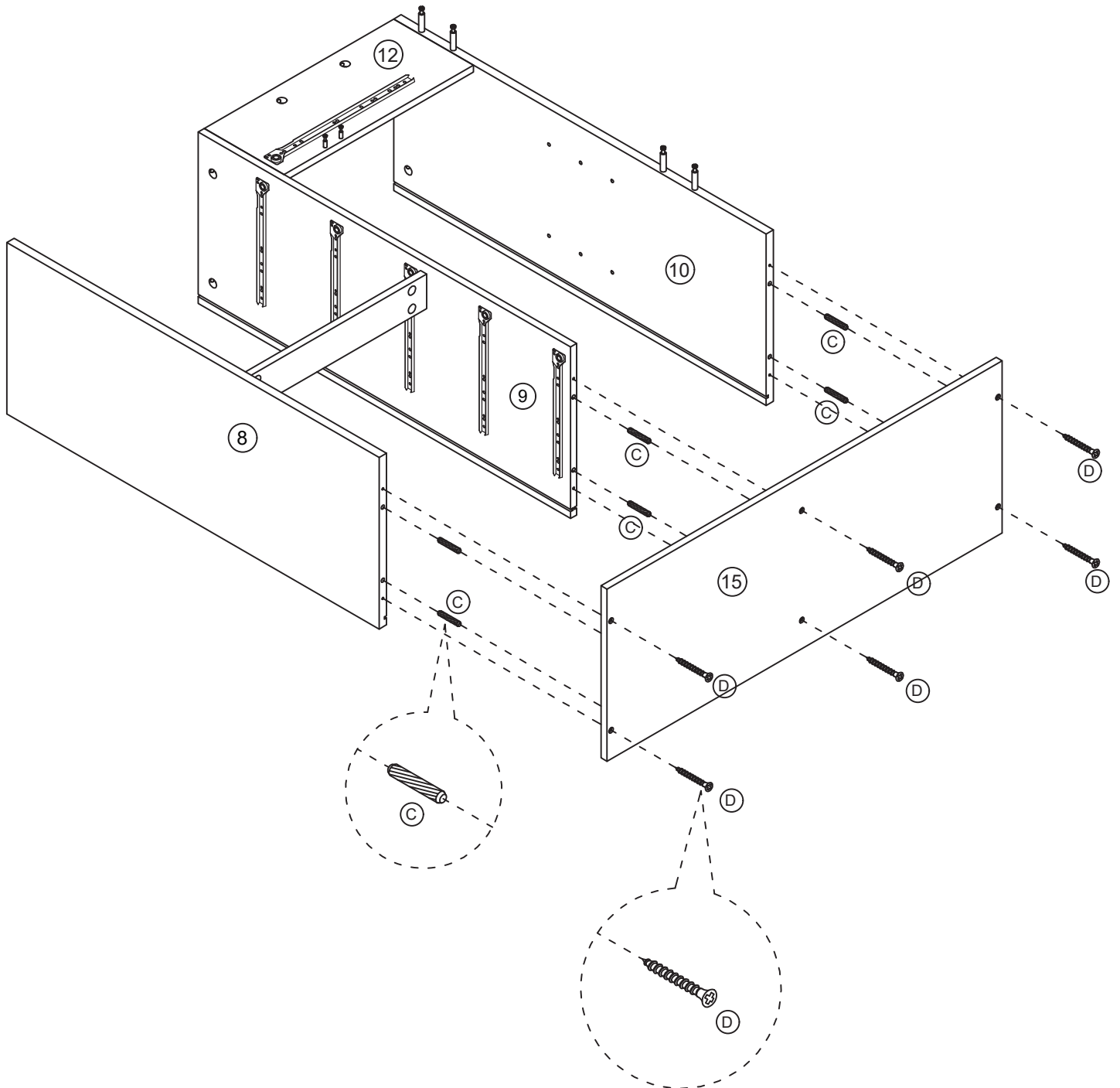
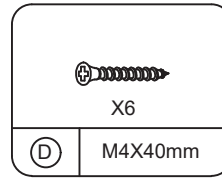
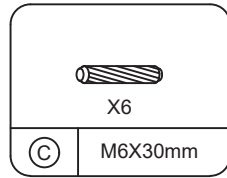

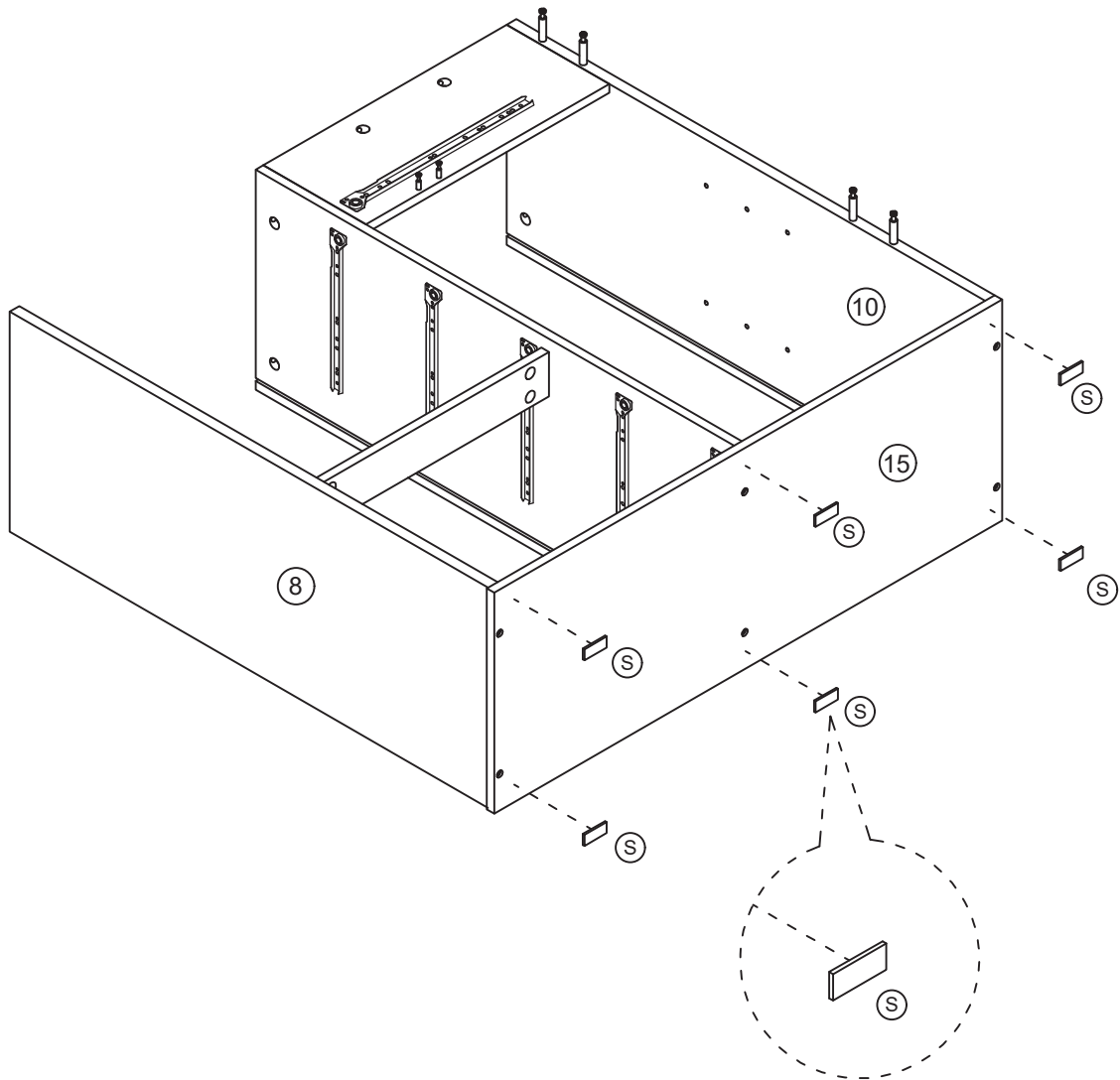
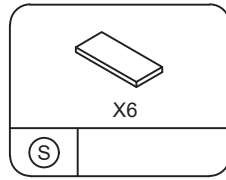

Peel off the film and stick it to the bottom of the cabinet feet.

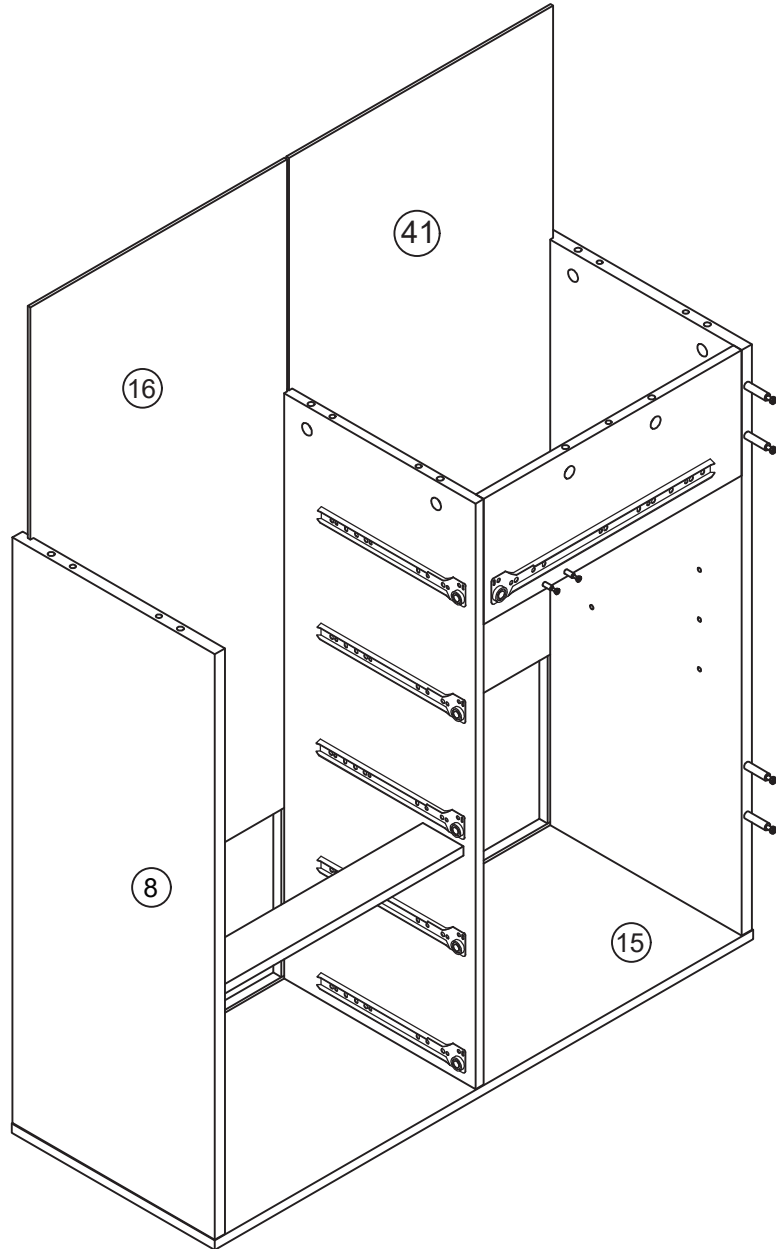

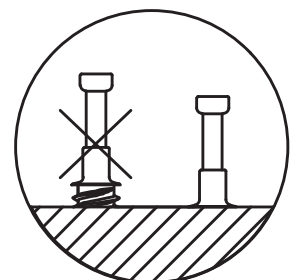
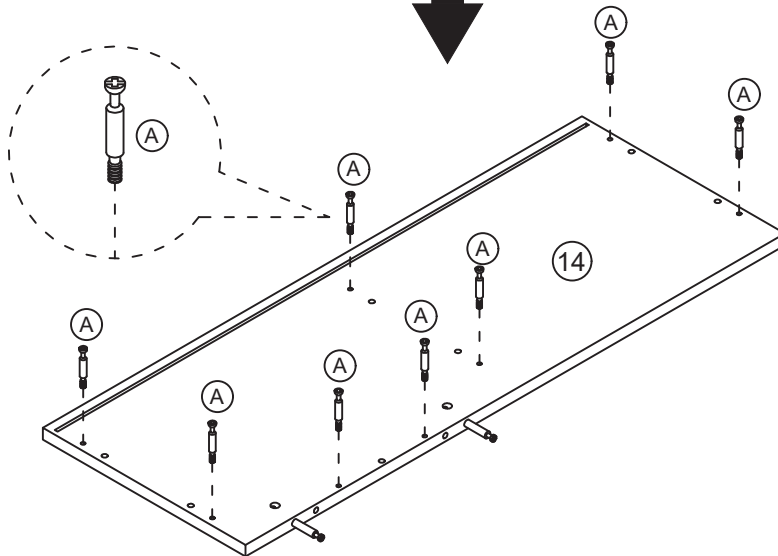
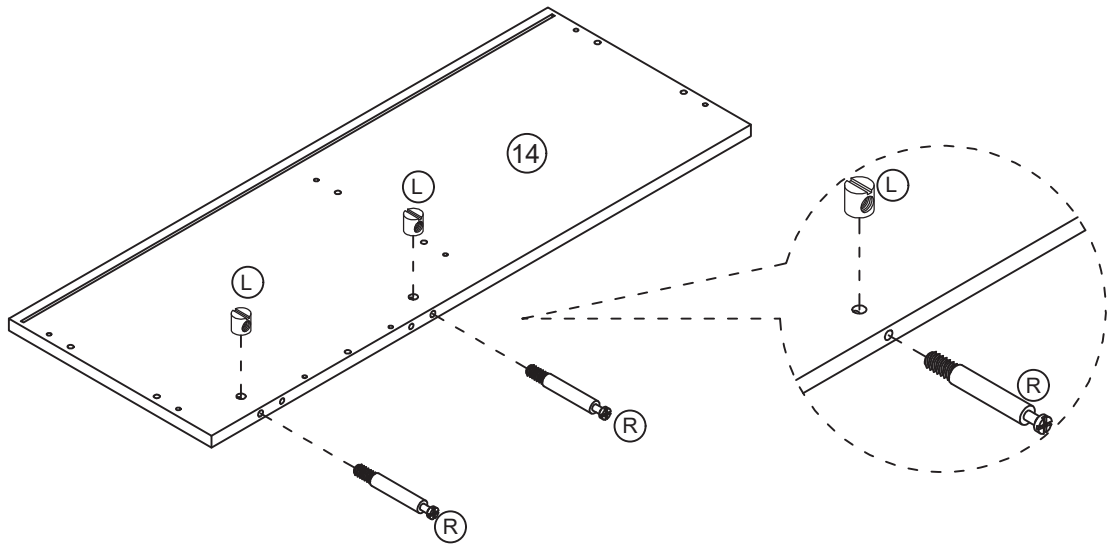
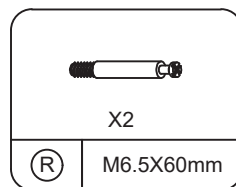
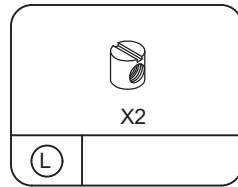
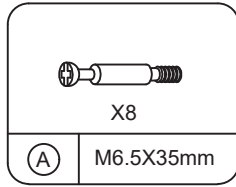

step 23

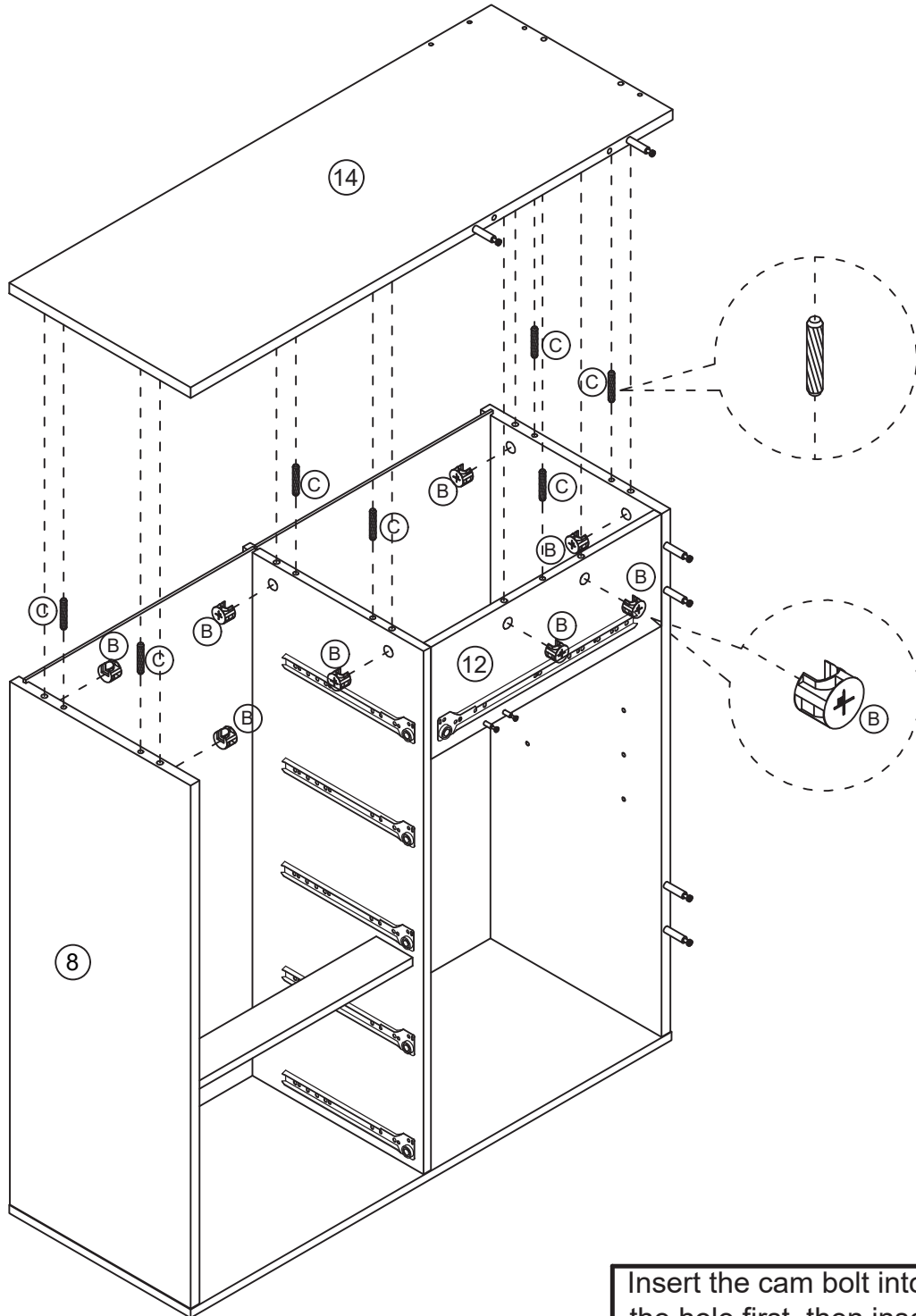
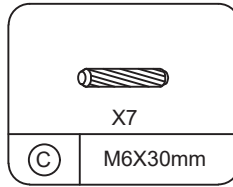
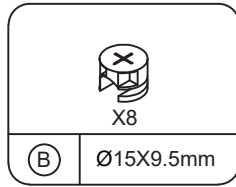

Insert the cam bolt into the hole first, then insert the cam lock and lock it.

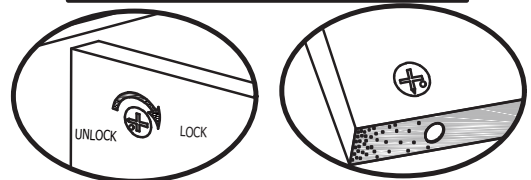

Proper orientation of CAM LOCK

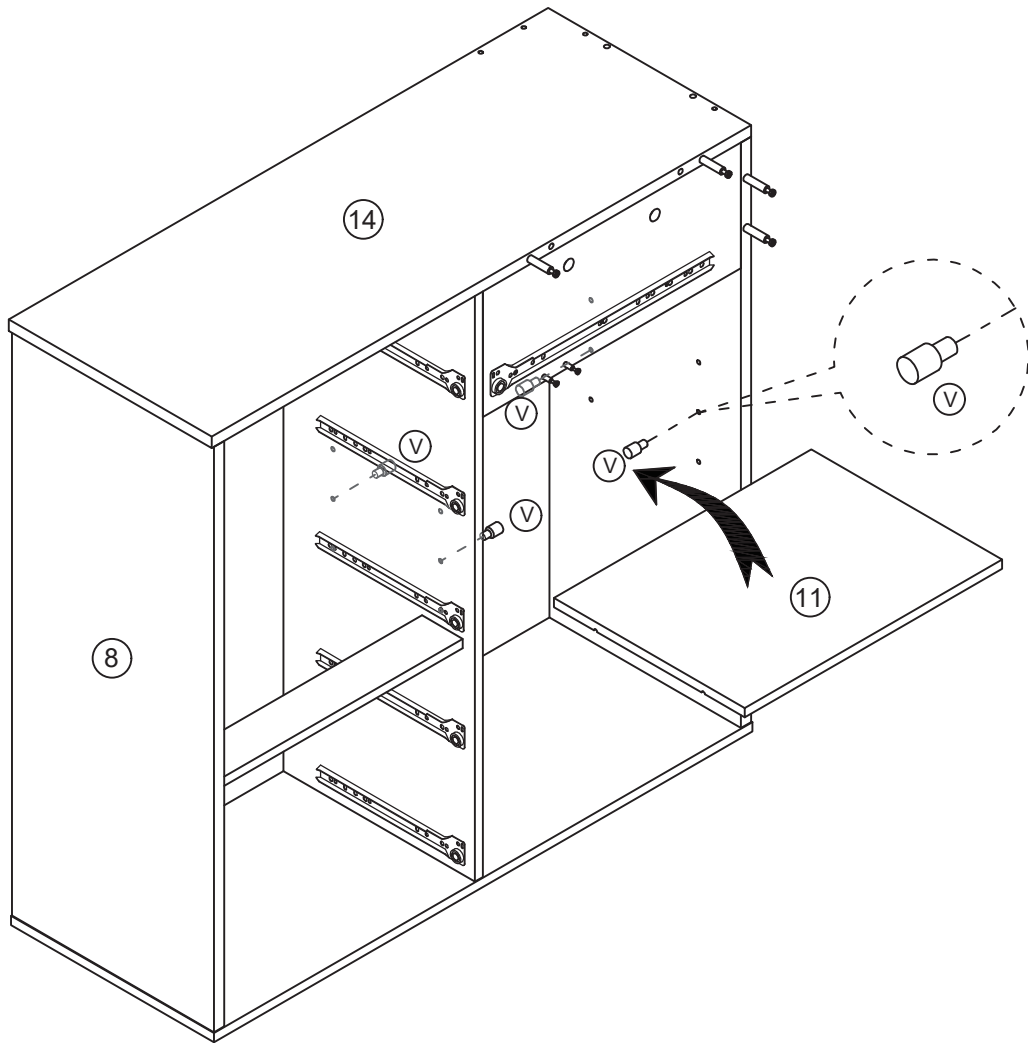
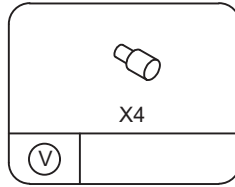

step 25

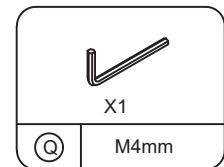
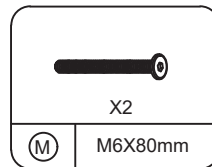
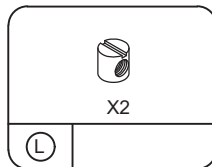
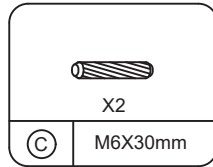
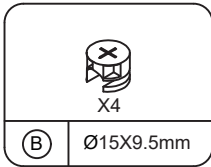

Insert the cam bolt into the hole first, then insert the cam lock and lock it.

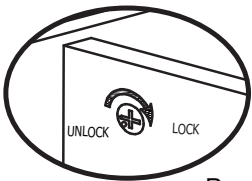

Proper orientation of CAM LOCK

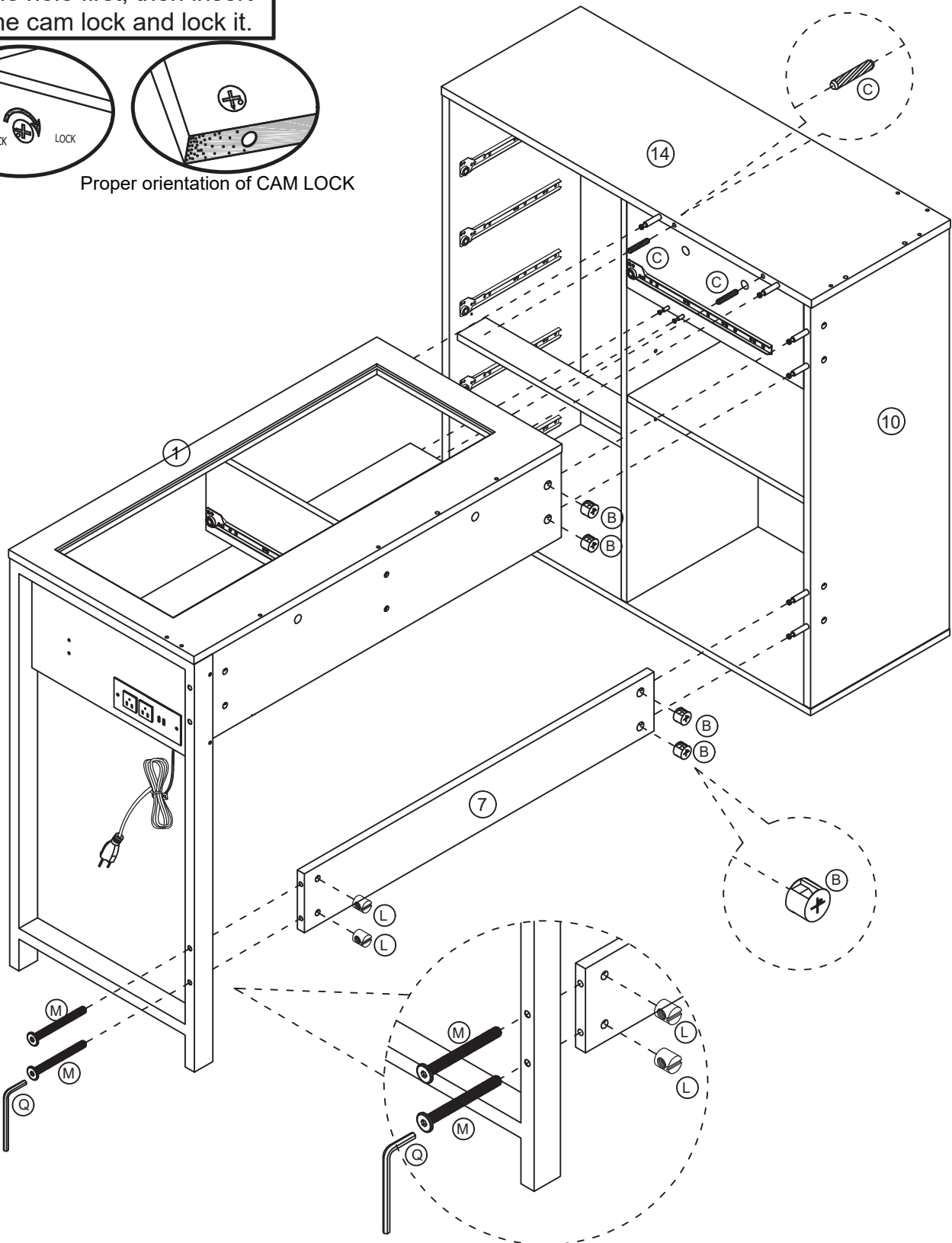

step 26

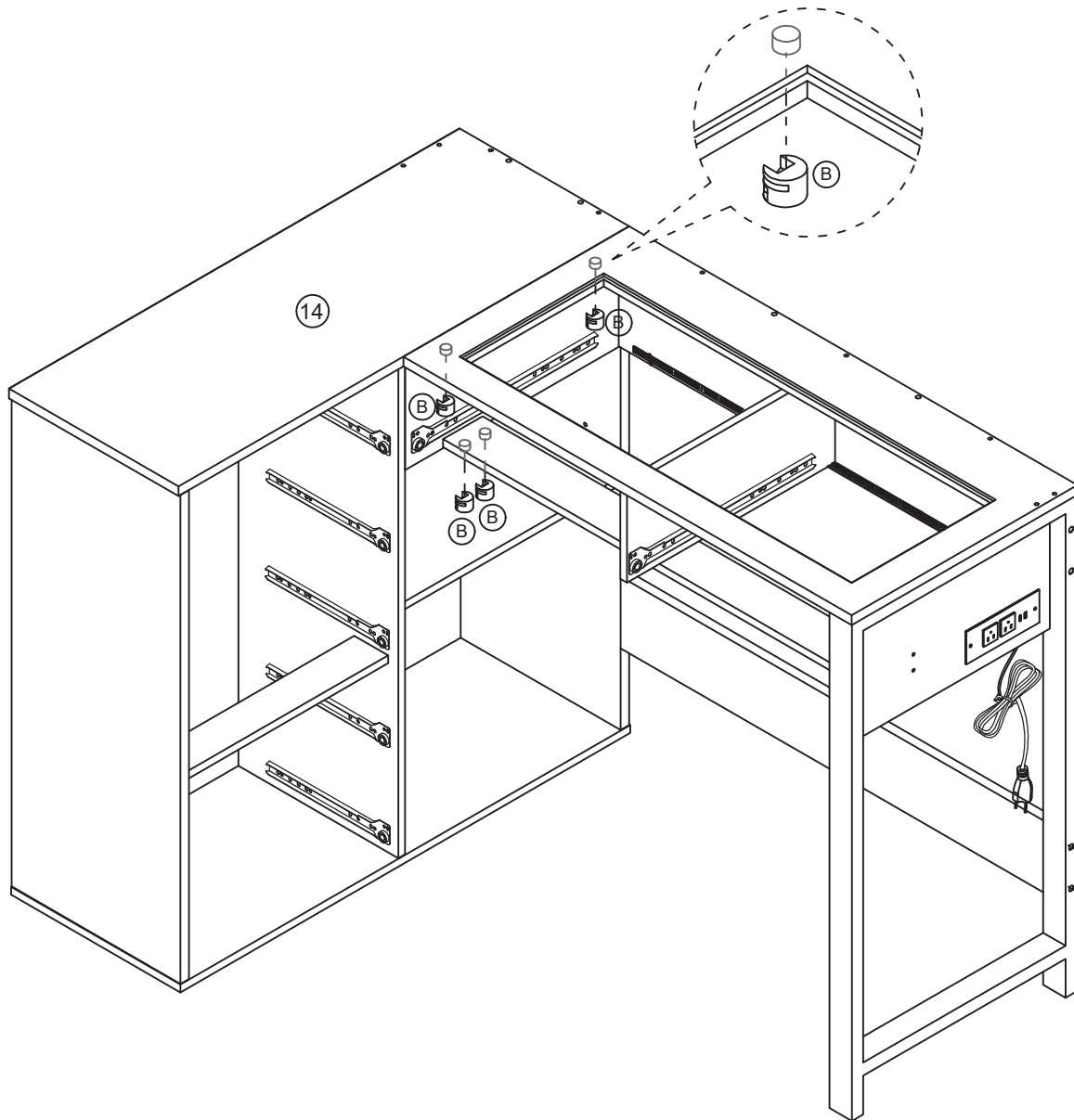
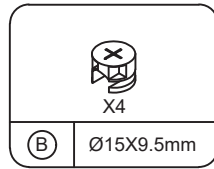

Insert the cam bolt into the hole first, then insert the cam lock and lock it.

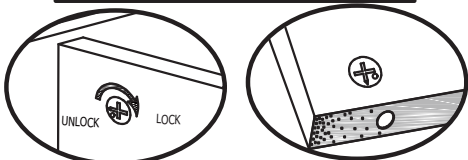

Proper orientation of CAM LOCK

step 27

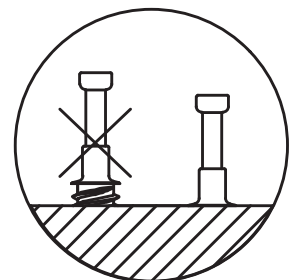
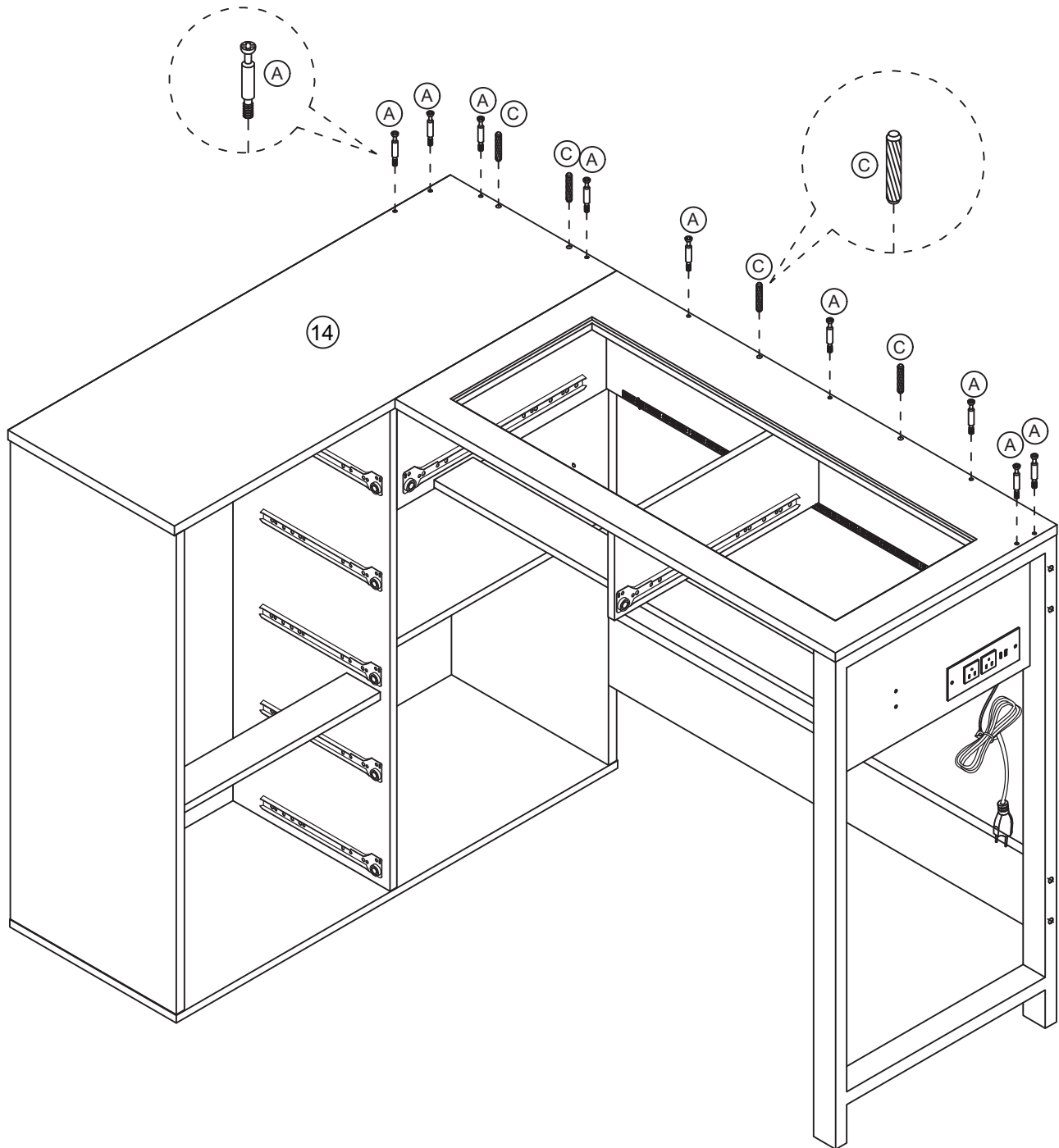
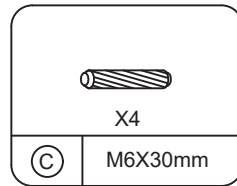
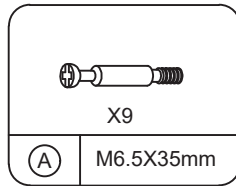

step 28

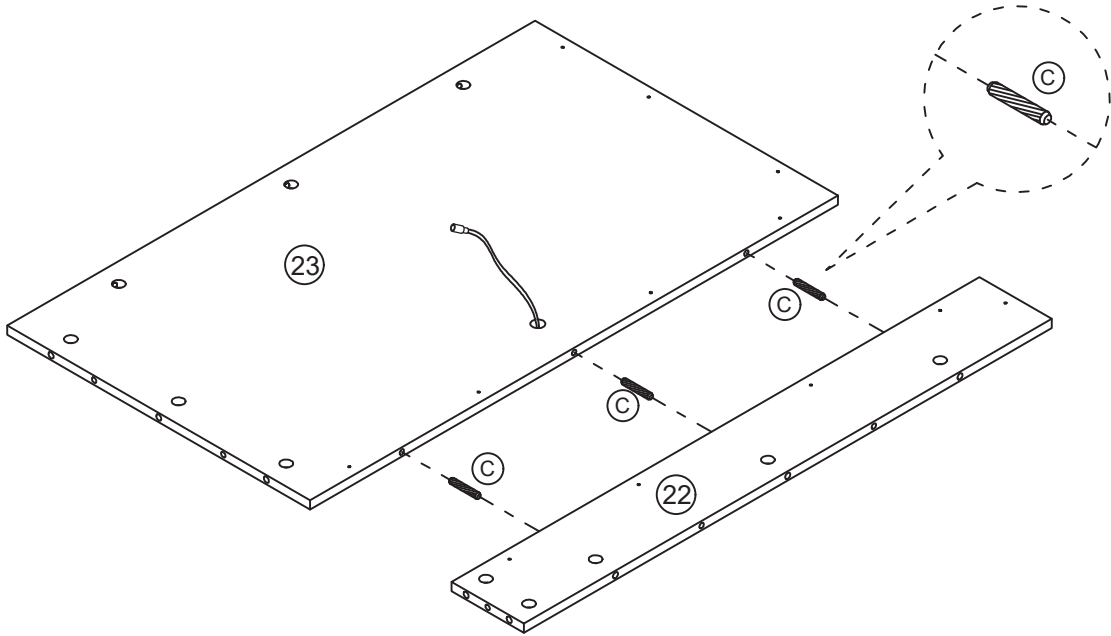
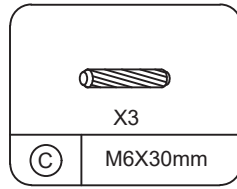

step 29

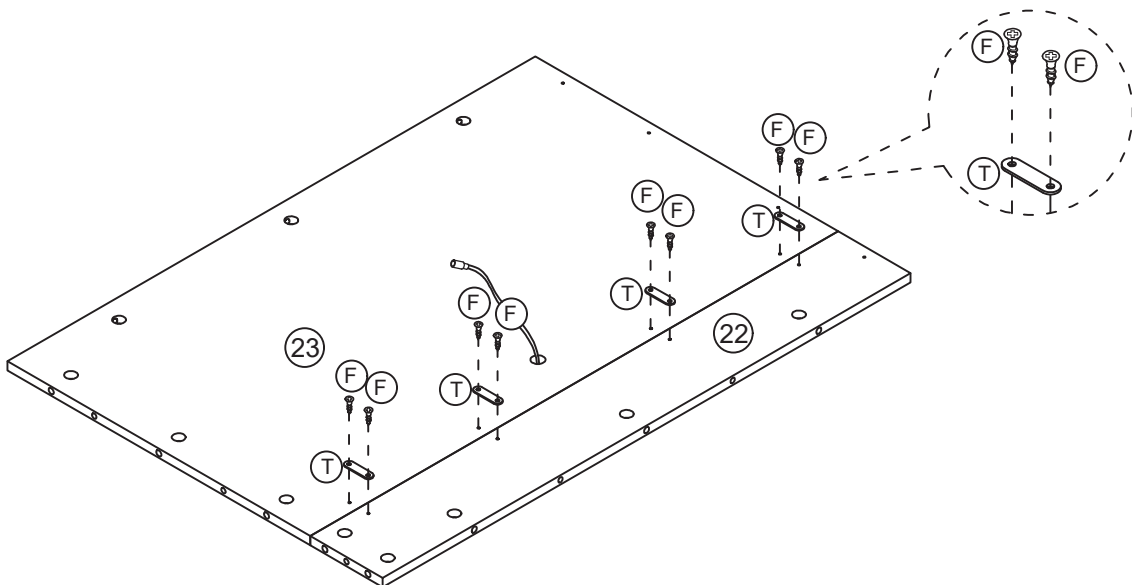
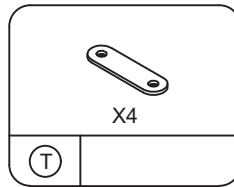
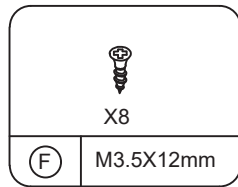

step 30

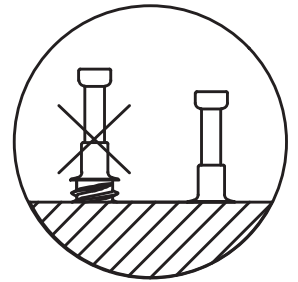
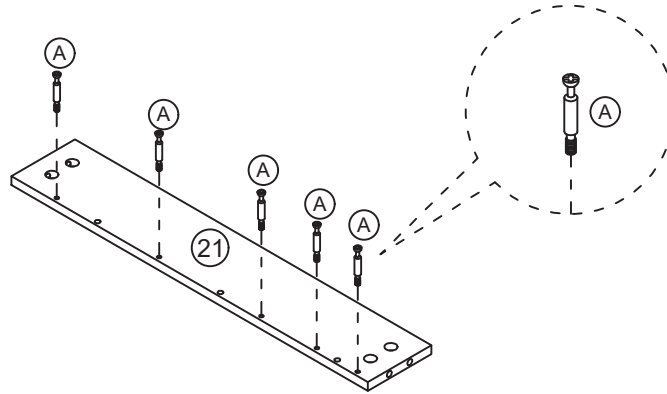
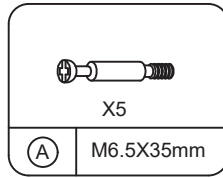

step 31

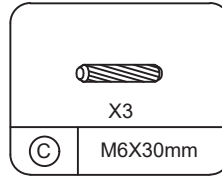
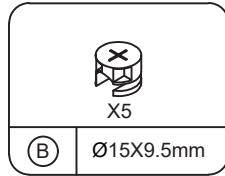

Insert the cam bolt into the hole first, then insert the cam lock and lock it.

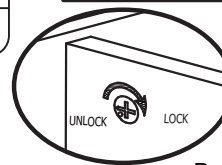

Proper orientation of CAM LOCK

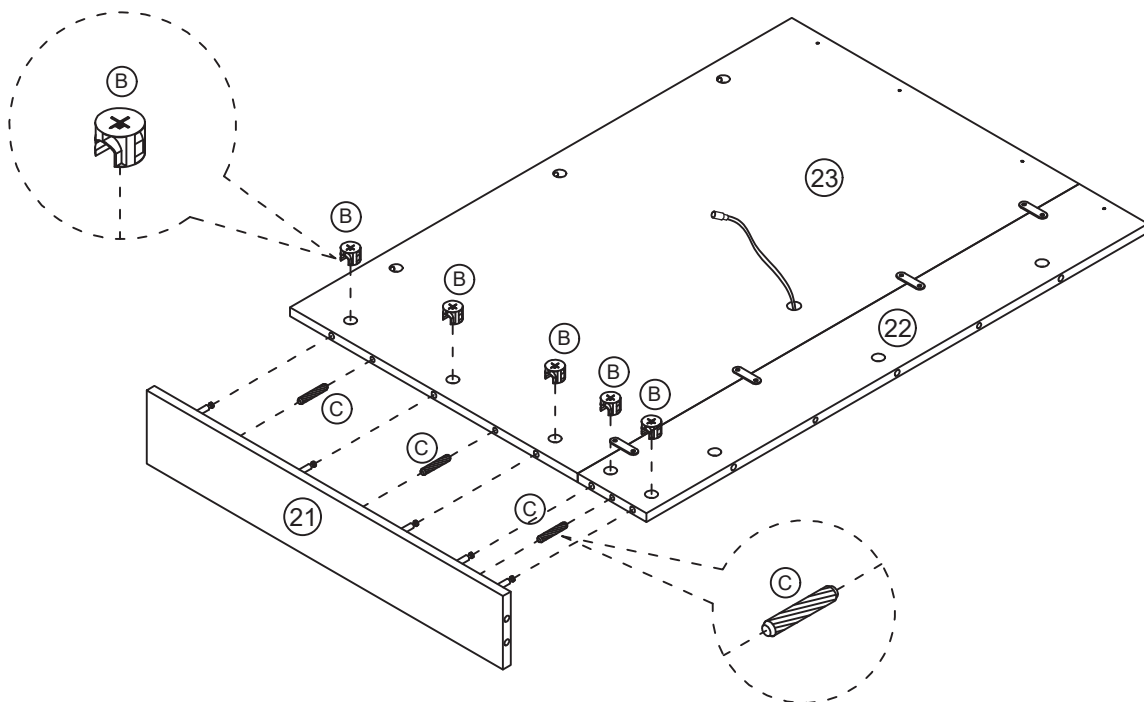

step 32

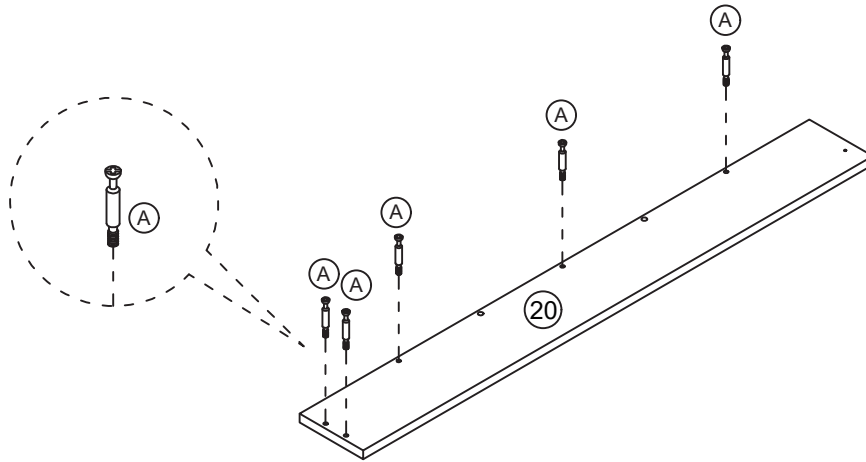
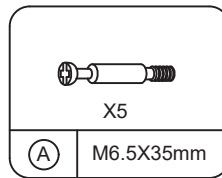

step 33

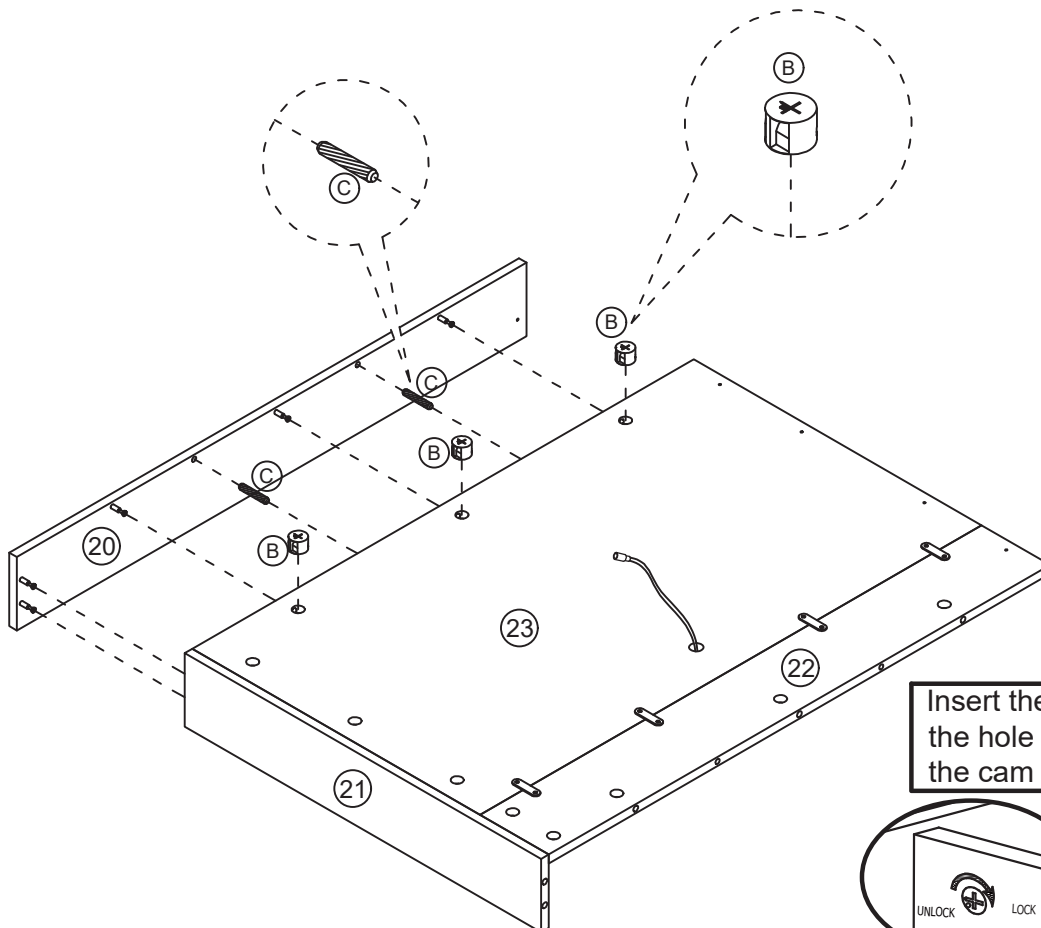
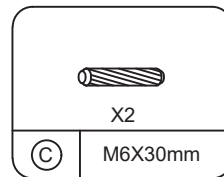
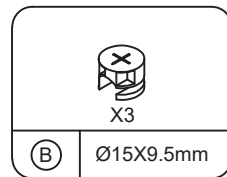

Insert the cam bolt into the hole first, then insert the cam lock and lock it.

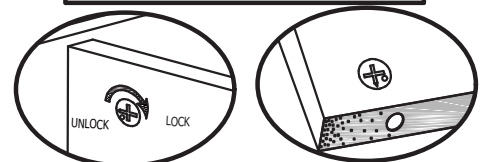

Proper orientation of CAM LOCK

step 34

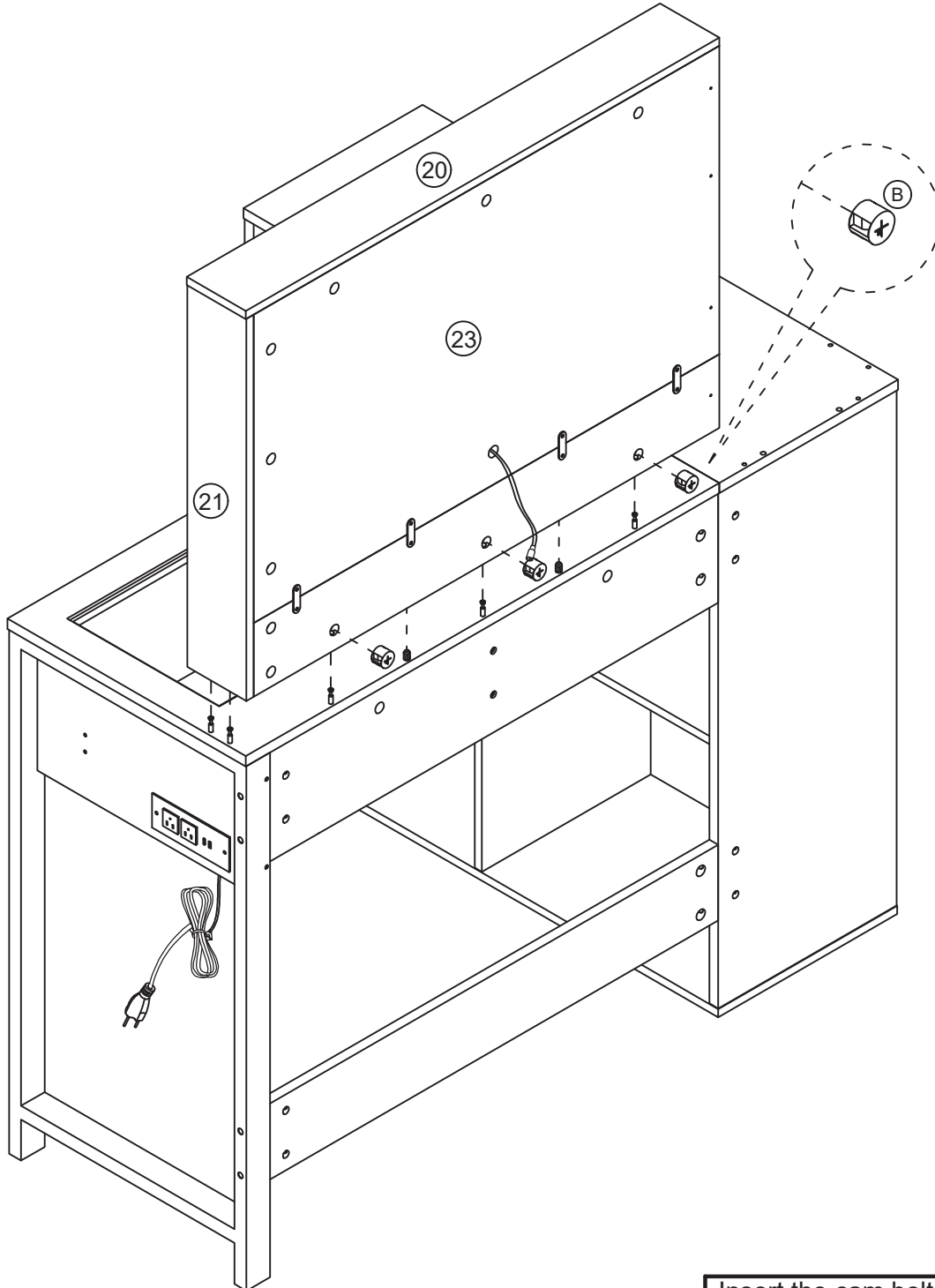
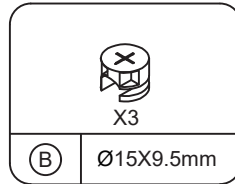

Insert the cam bolt into the hole first, then insert the cam lock and lock it.

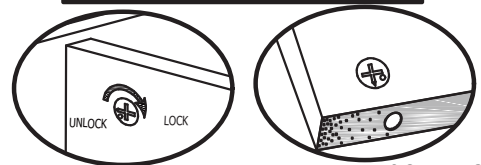

Proper orientation of CAM LOCK

step 35

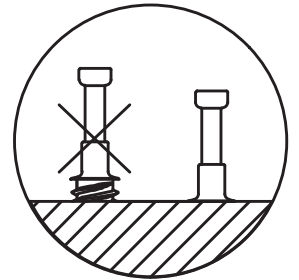
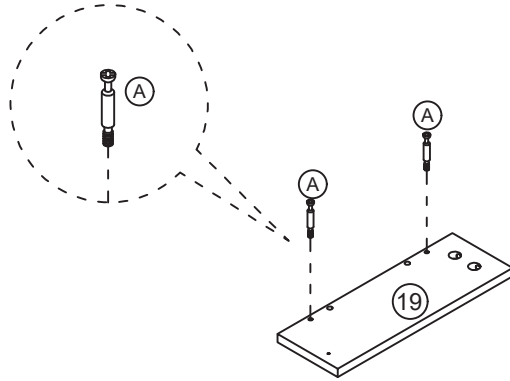
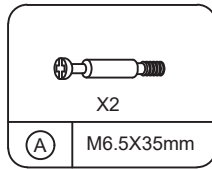

step 36

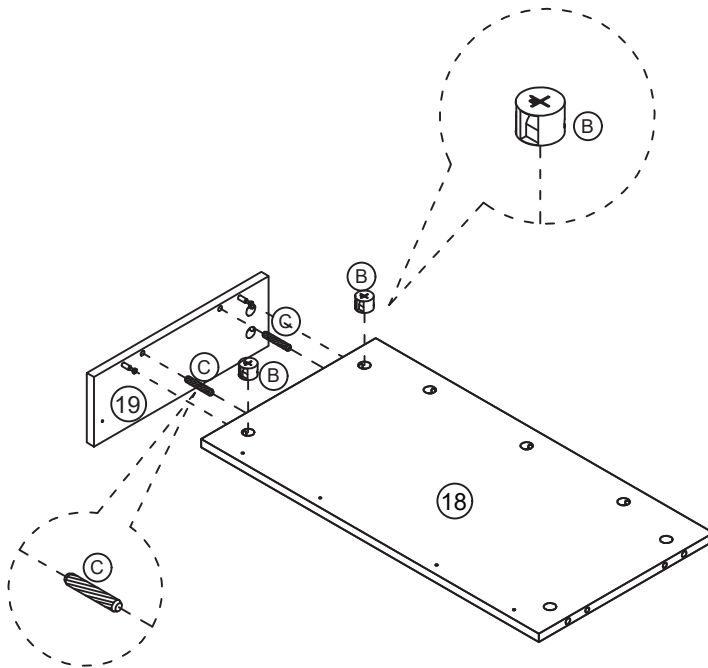
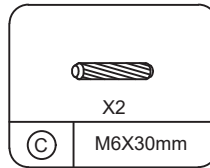
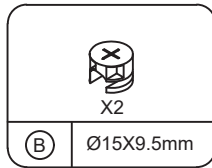

Insert the cam bolt into the hole first, then insert the cam lock and lock it.

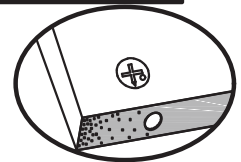

Proper orientation of CAM LOCK

step 37

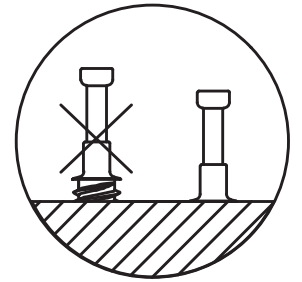
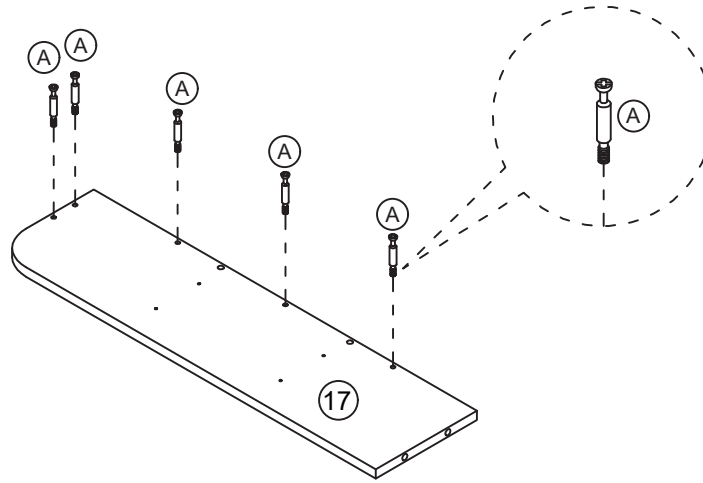
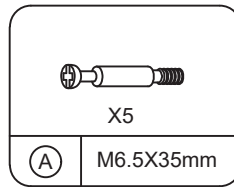

step 38

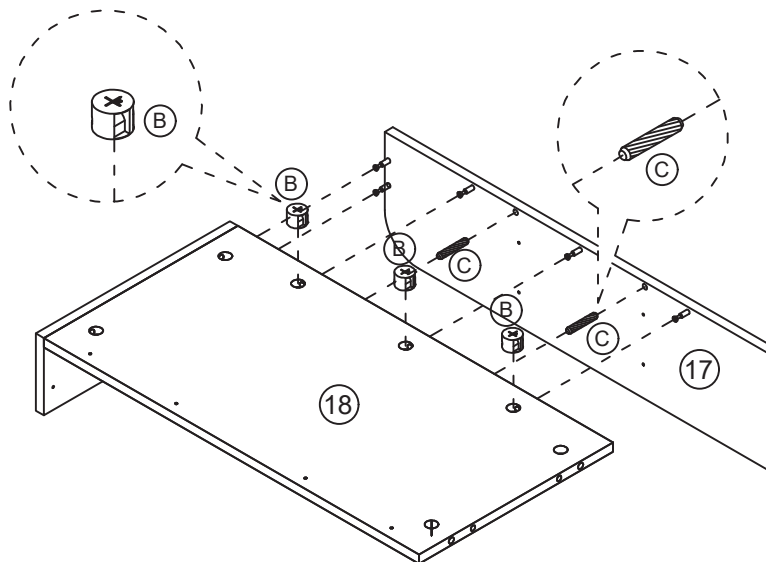
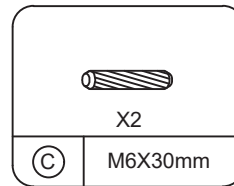
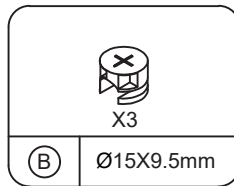

Insert the cam bolt into the hole first, then insert the cam lock and lock it.

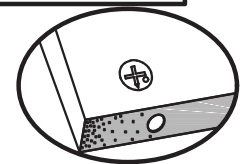
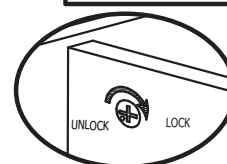

Proper orientation of CAM LOCK

step 39

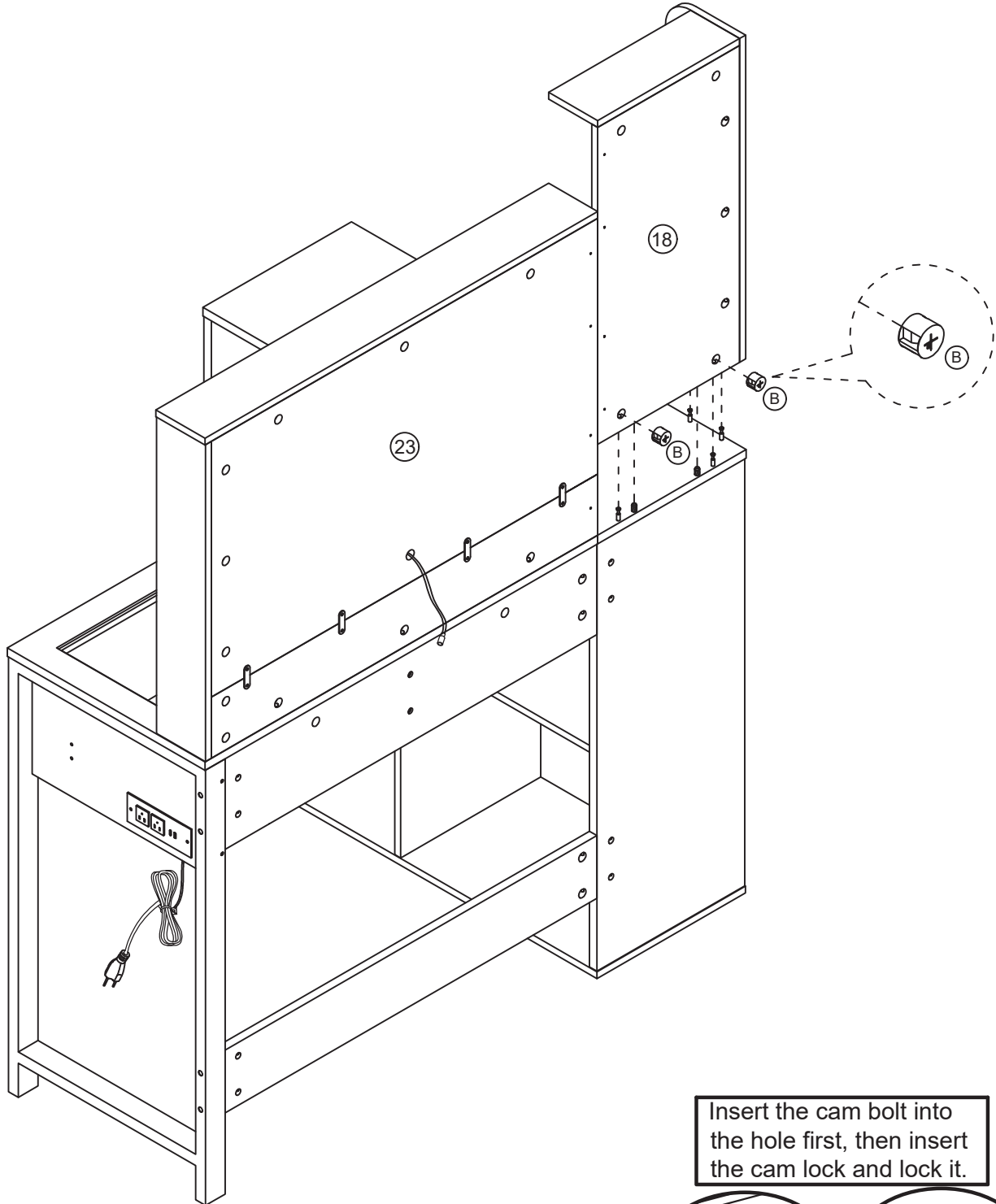
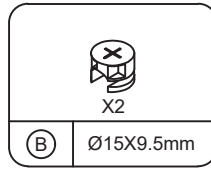

Insert the cam bolt into the hole first, then insert the cam lock and lock it.

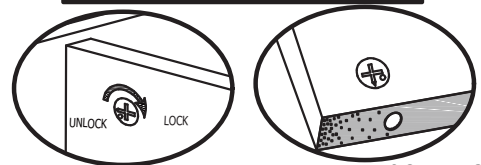

Proper orientation of CAM LOCK

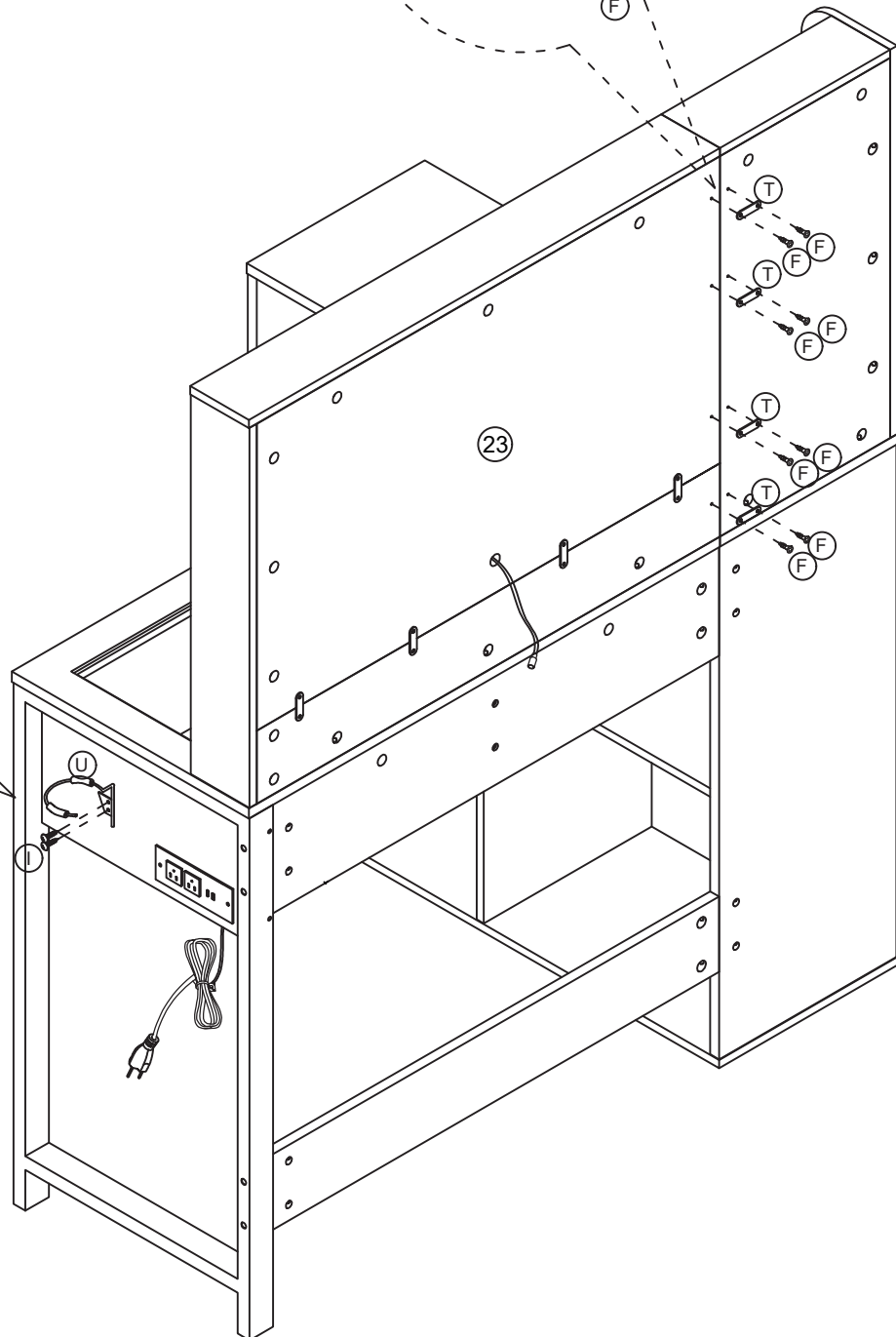
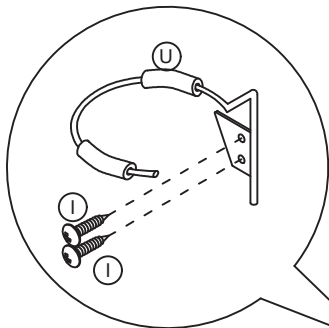
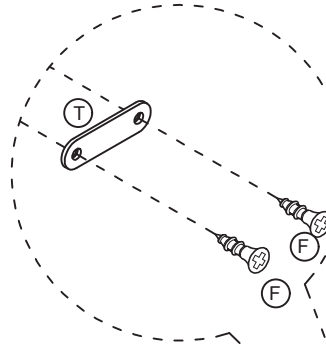
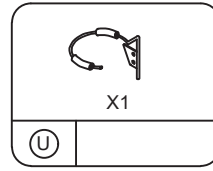
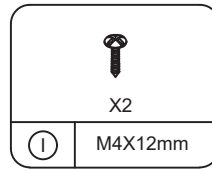
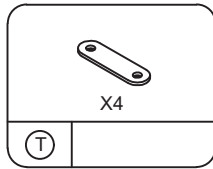
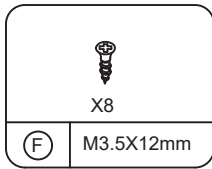

step 41

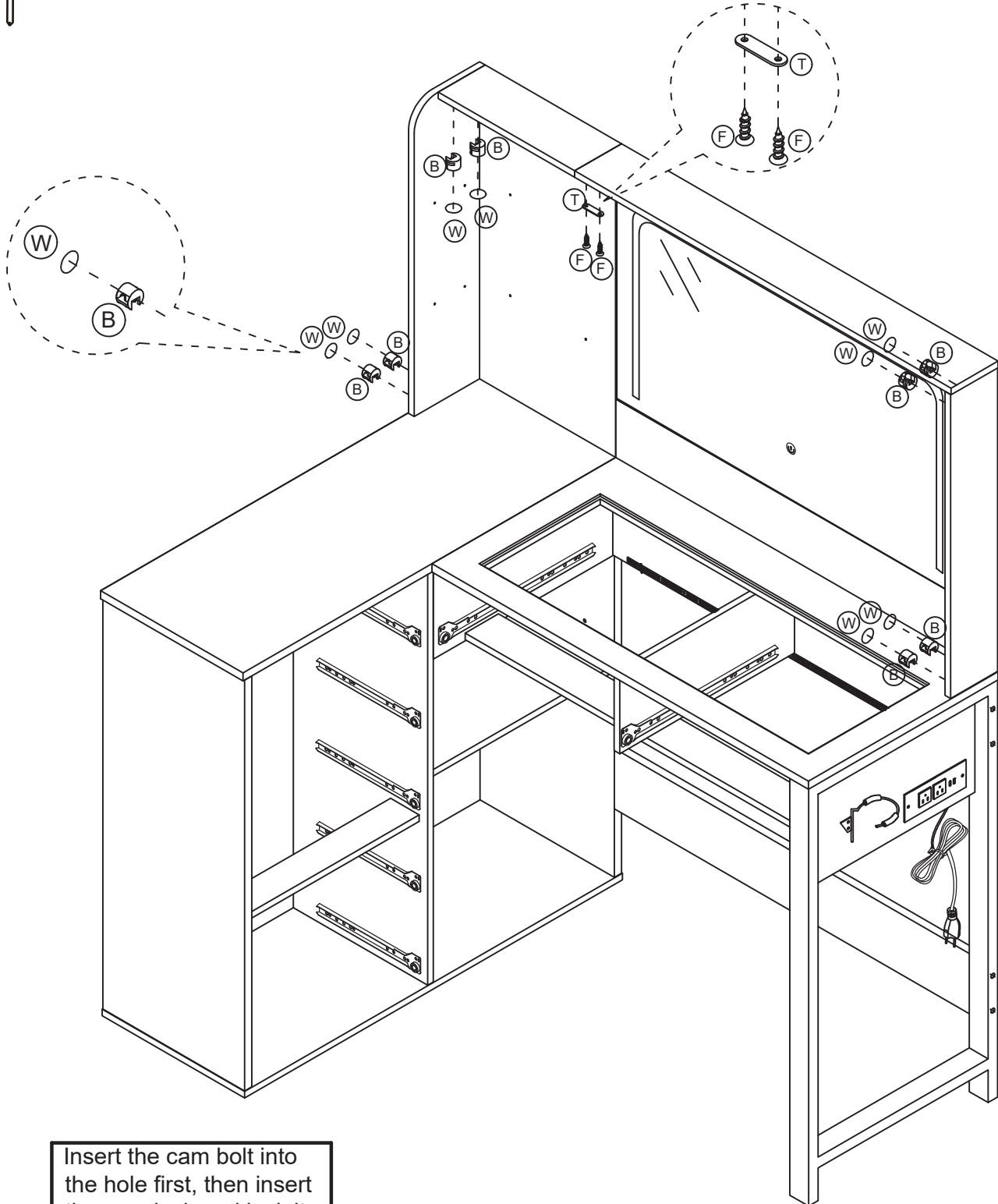
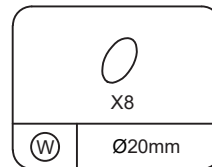
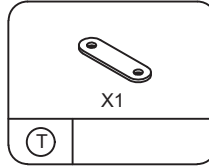
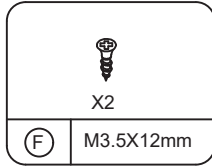
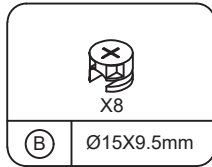

Insert the cam bolt into the hole first, then insert the cam lock and lock it.

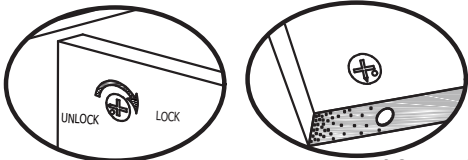

Proper orientation of CAM LOCK

step 42

**INSTALLATION
INSTRUCTIONS**

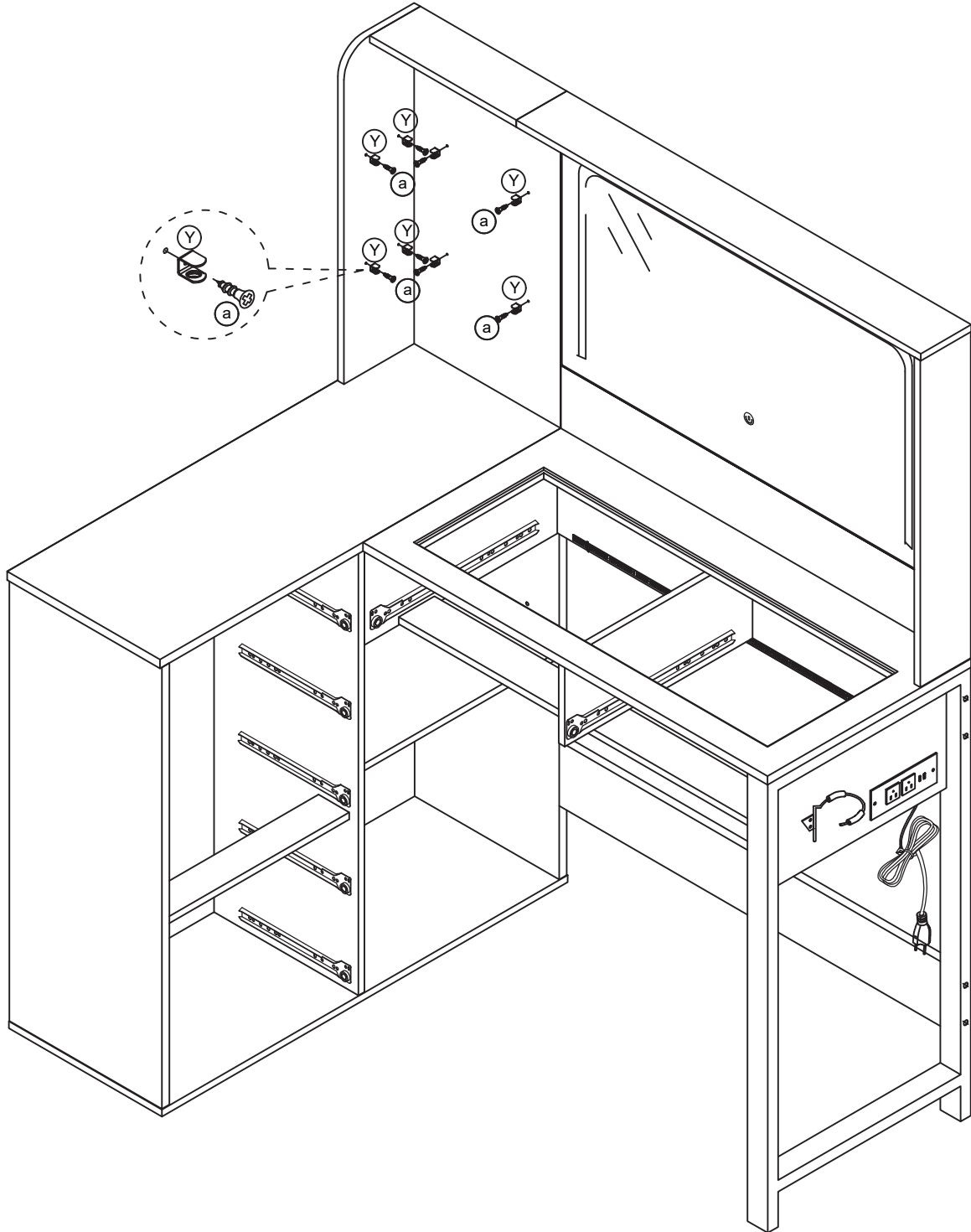
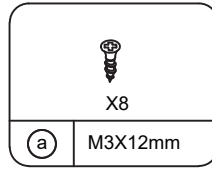
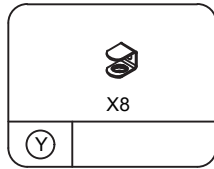

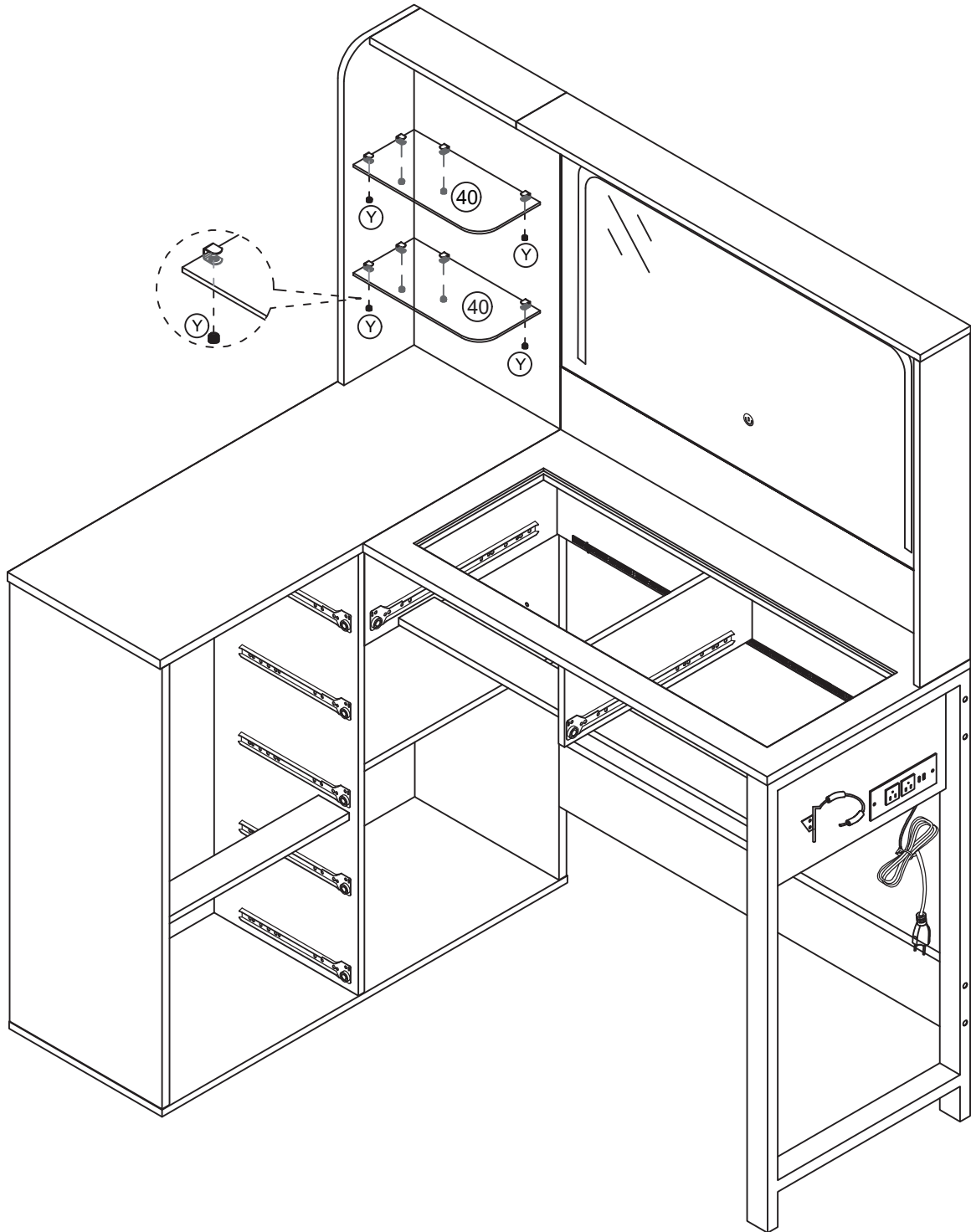
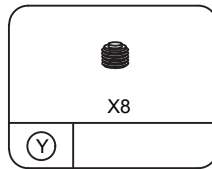

step 44

X2

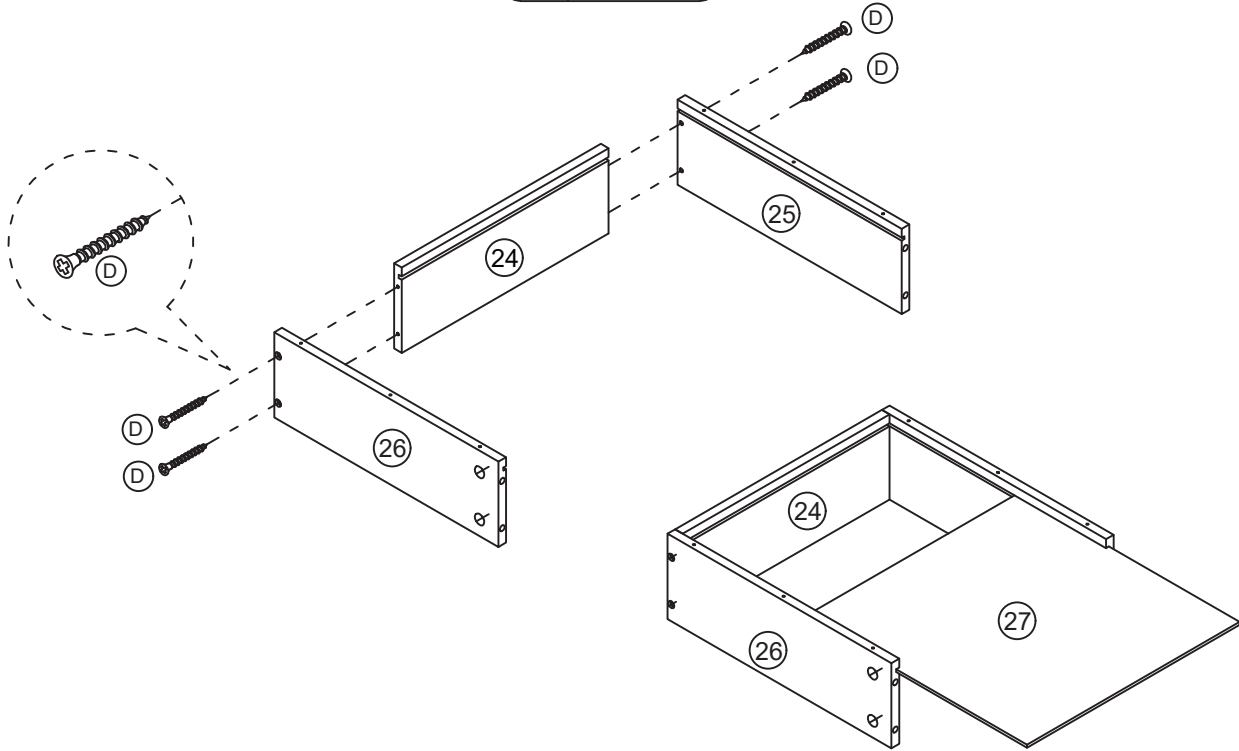
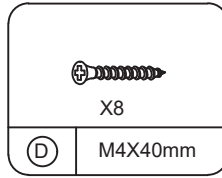

step 45

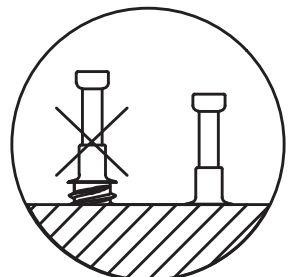
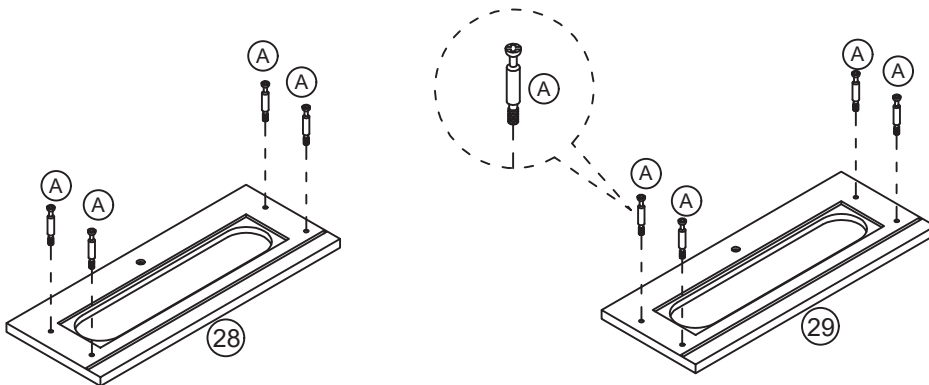
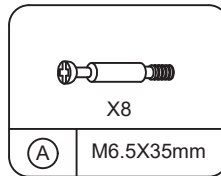

X2

step 46

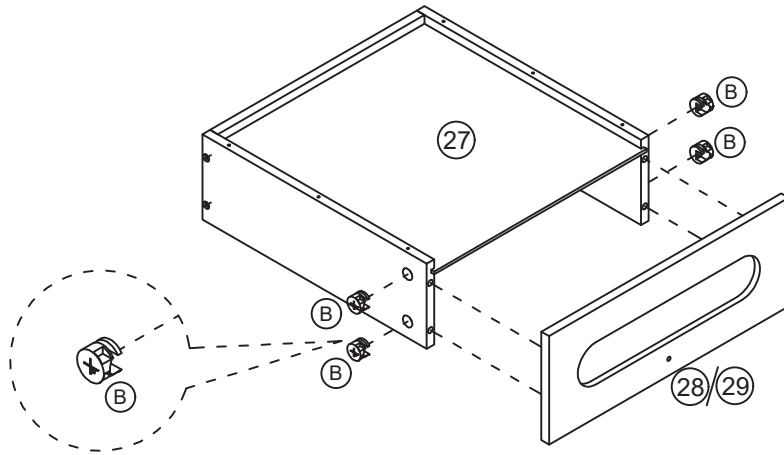
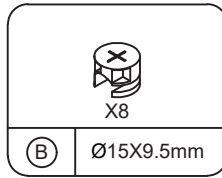

Insert the cam bolt into the hole first, then insert the cam lock and lock it.

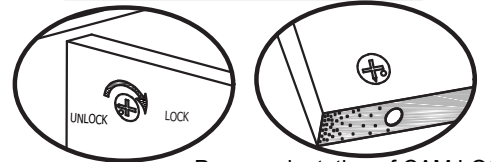

Proper orientation of CAM LOCK

step 47

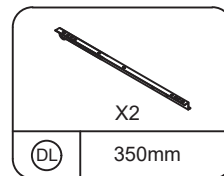
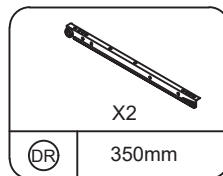
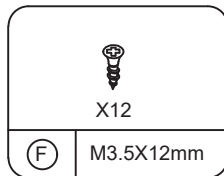

X2

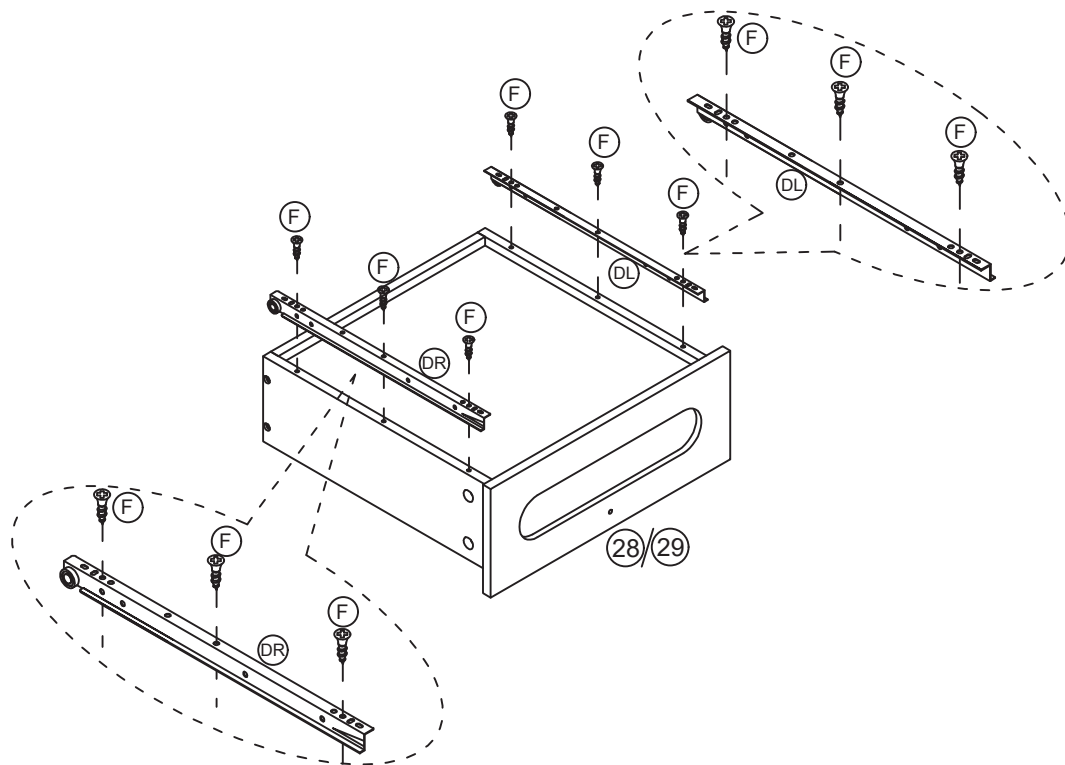

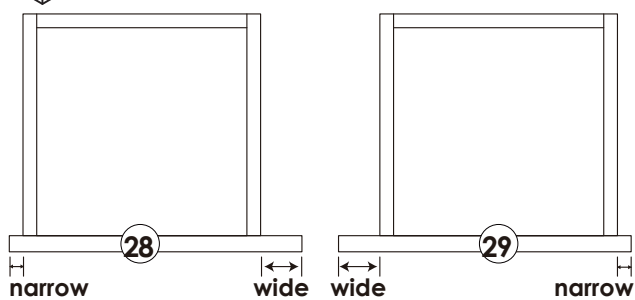
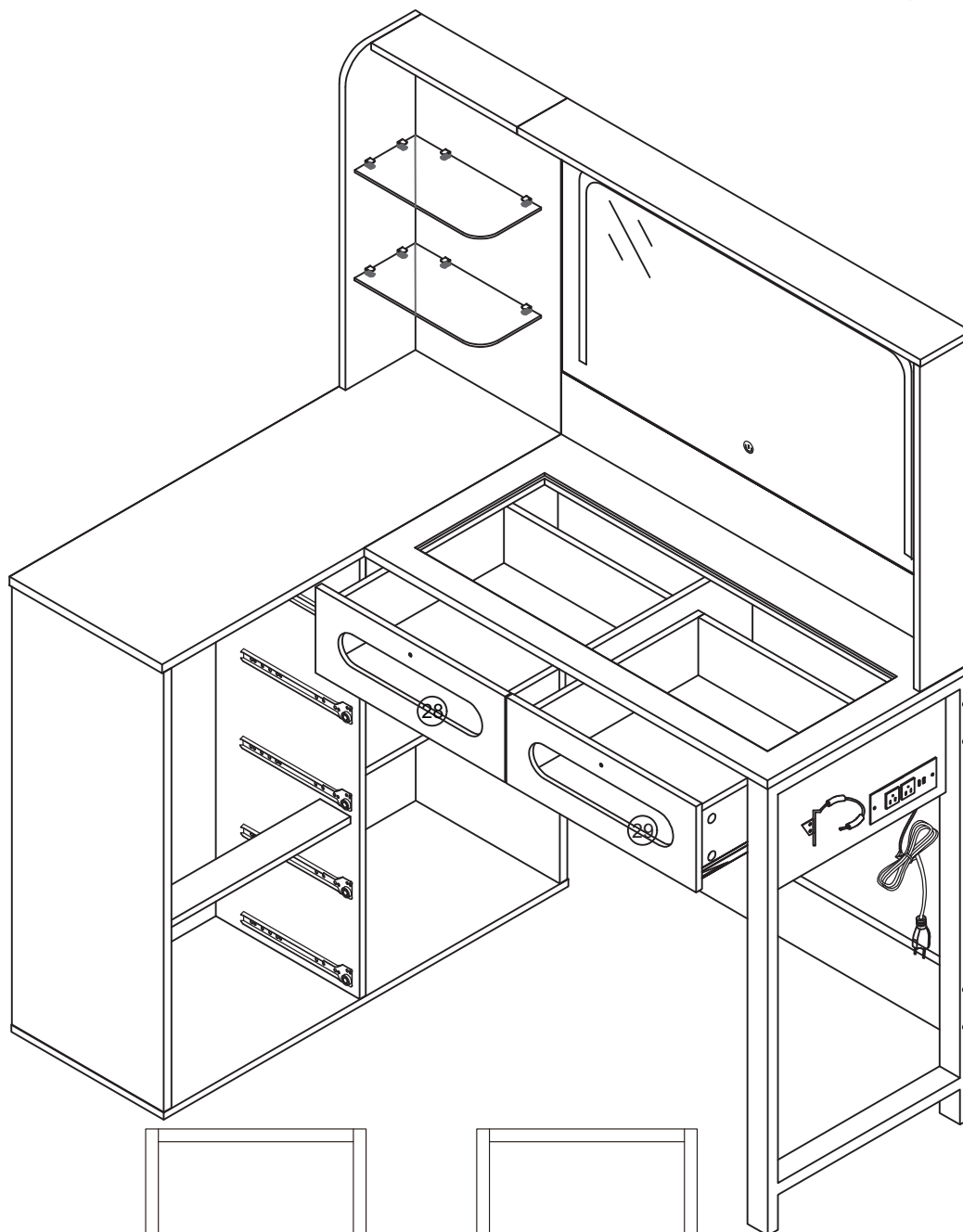

**Please identify #28 and #29.
Make sure #28 is for left drawer and
#29 is for right drawer.**

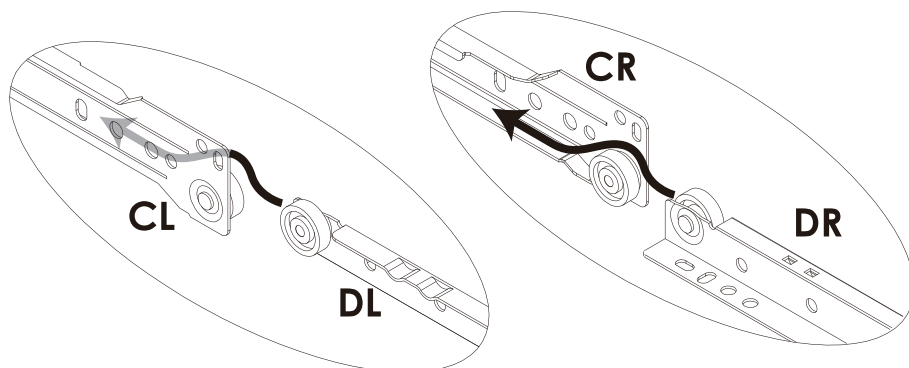

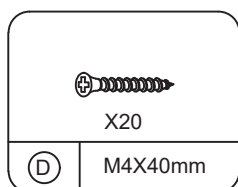
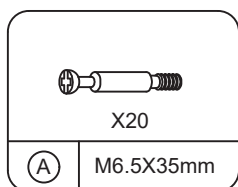

X5

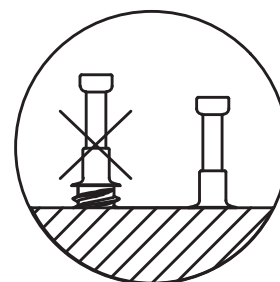
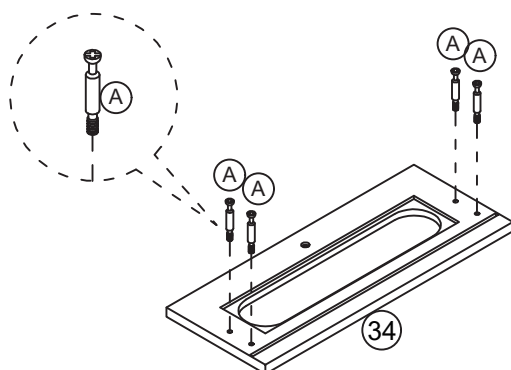
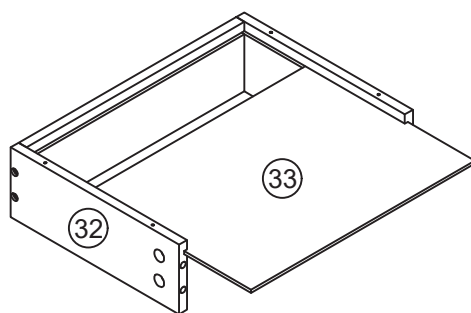
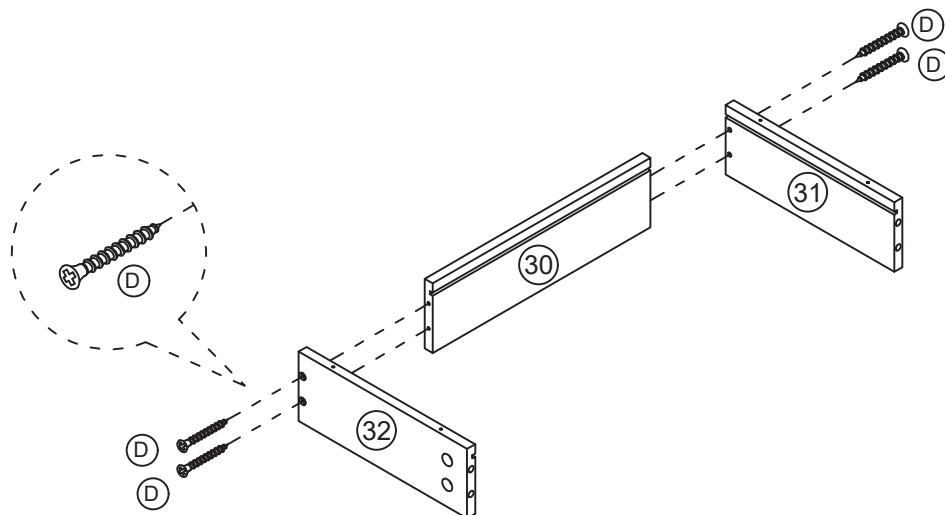

step 50

X5

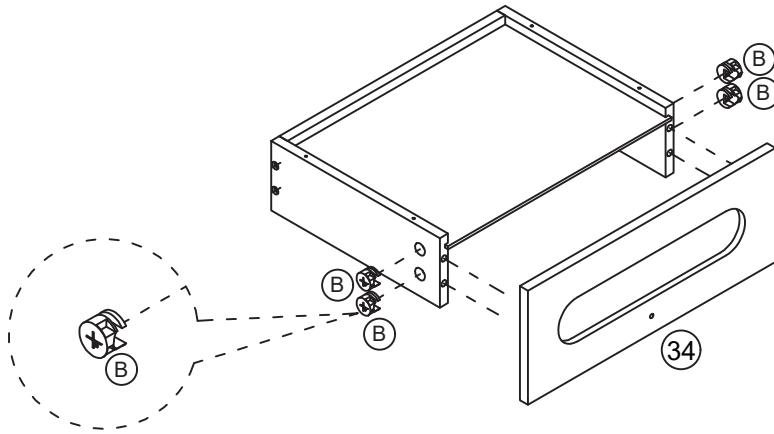
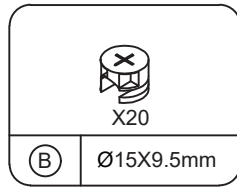

Insert the cam bolt into the hole first, then insert the cam lock and lock it.

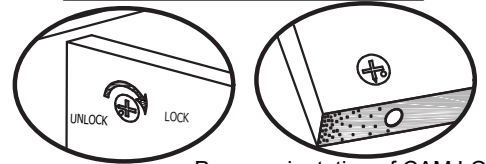

Proper orientation of CAM LOCK

step 51

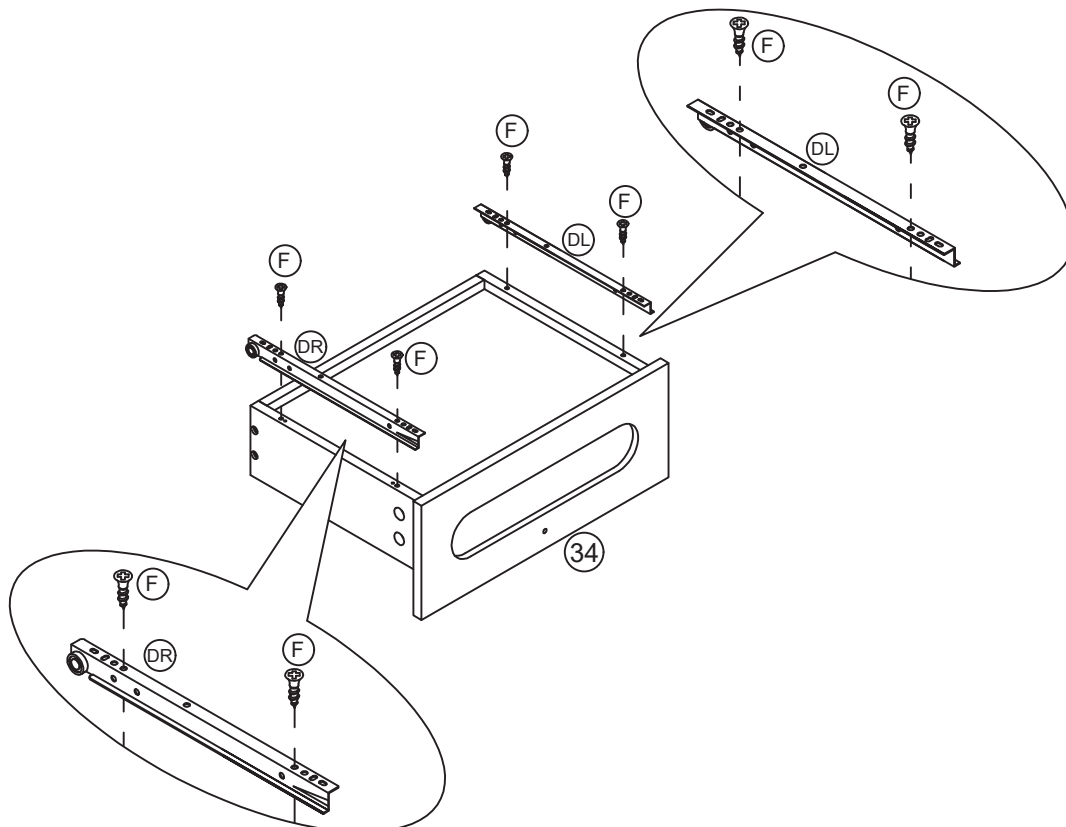
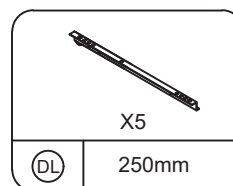
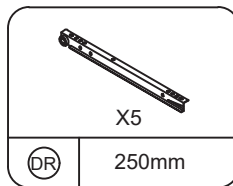
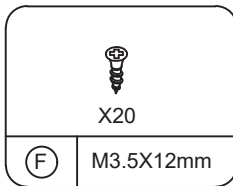

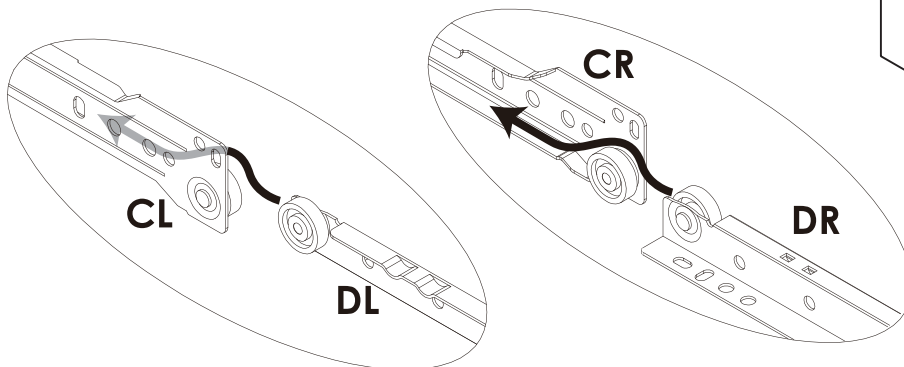
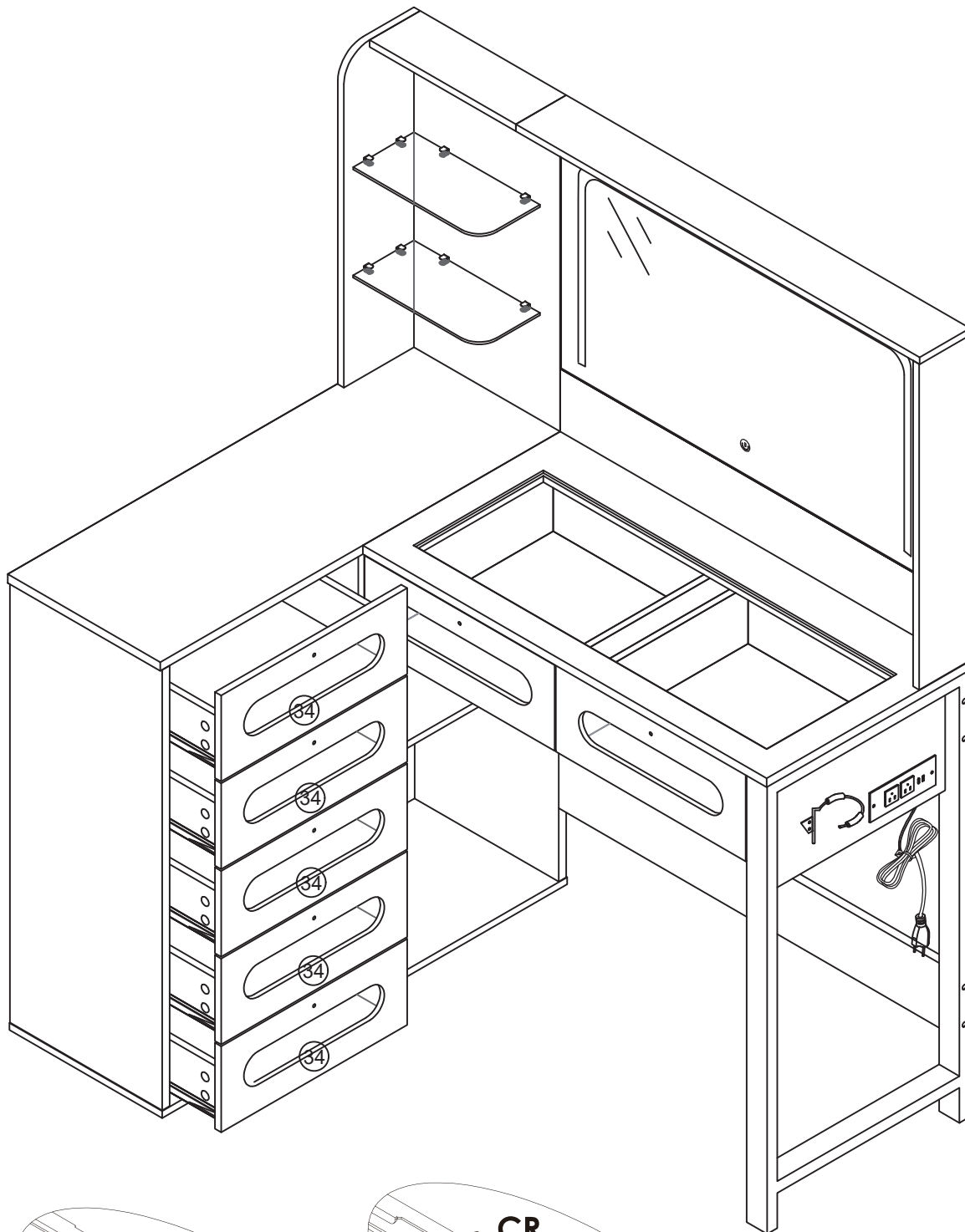

step 53

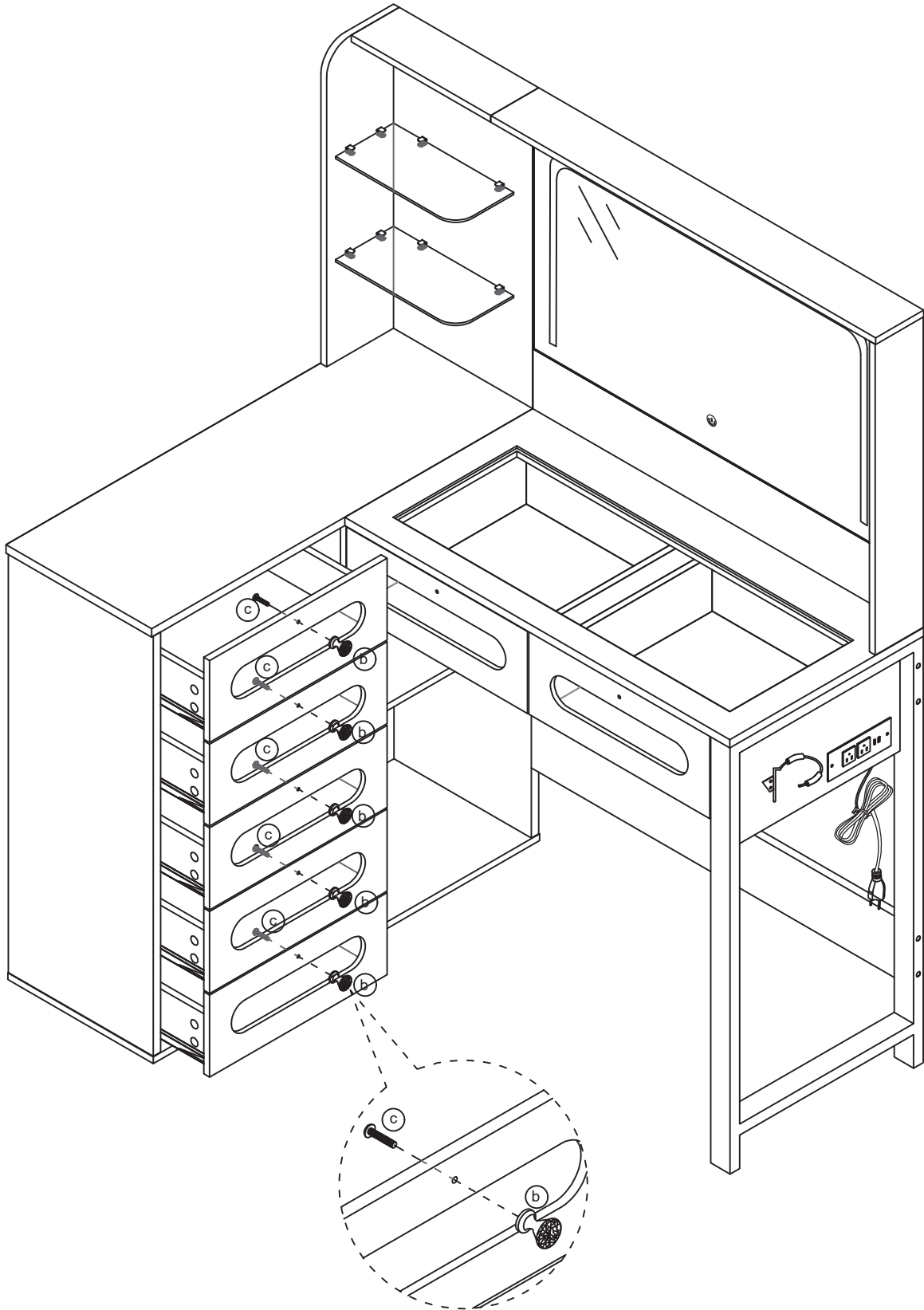
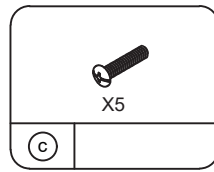
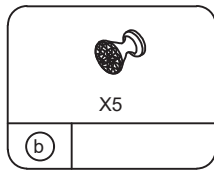

step 54

**INSTALLATION
INSTRUCTIONS**

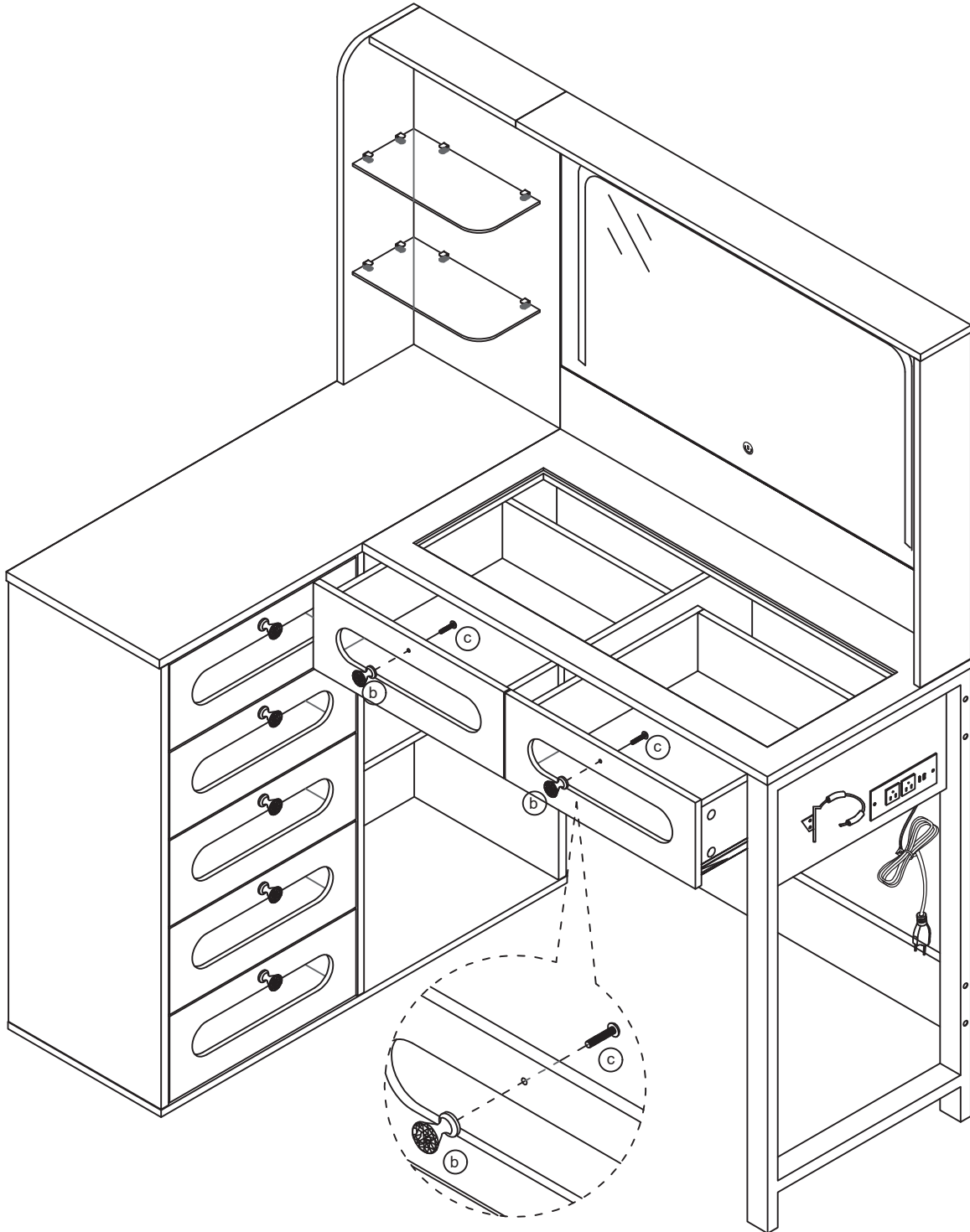
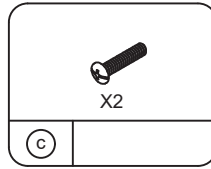
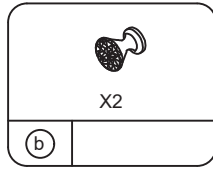

step 55

**INSTALLATION
INSTRUCTIONS**

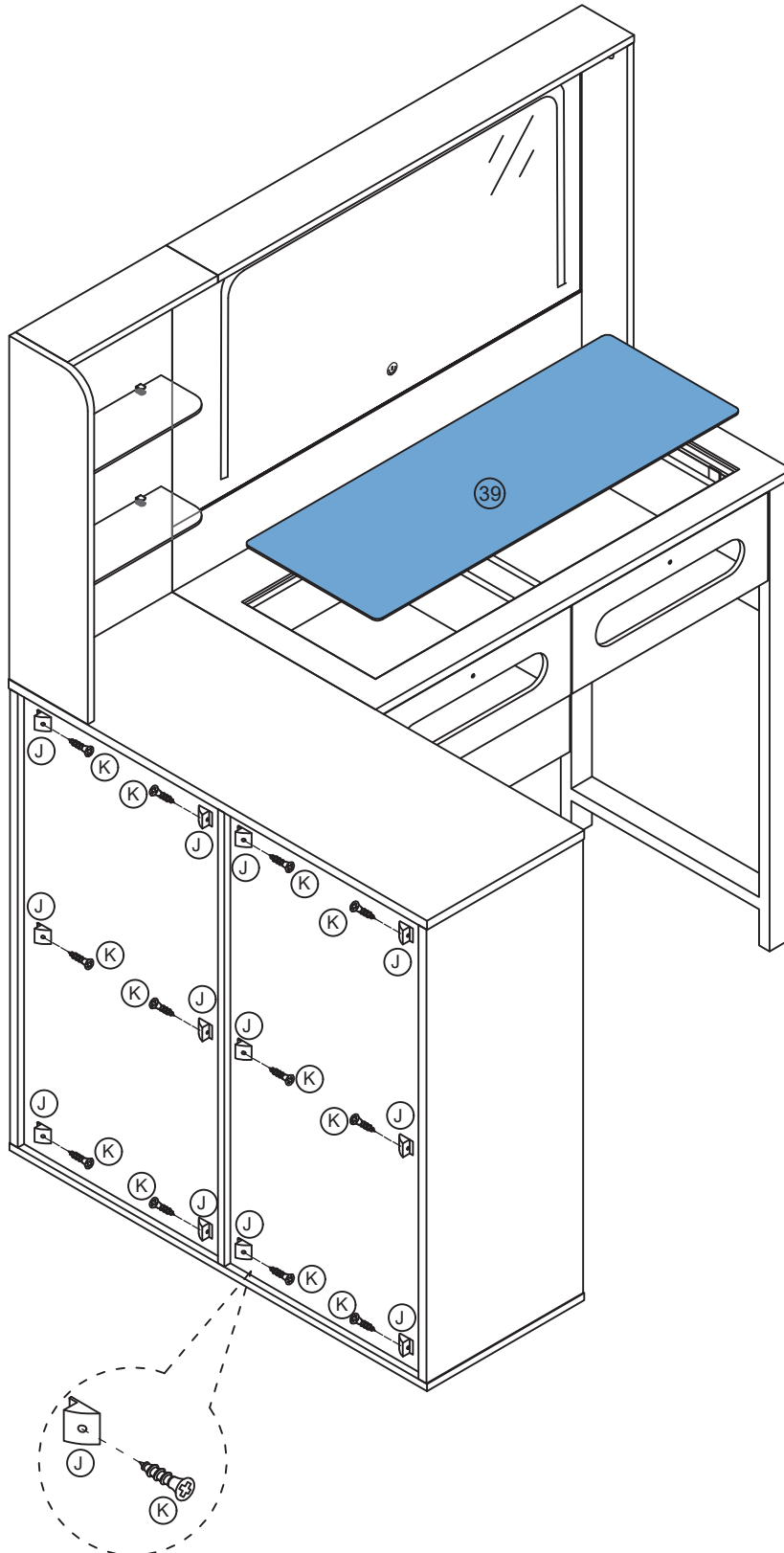
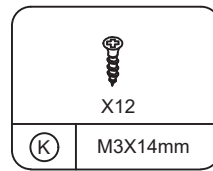
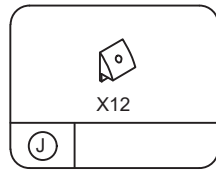

step 56

INSTALLATION INSTRUCTIONS

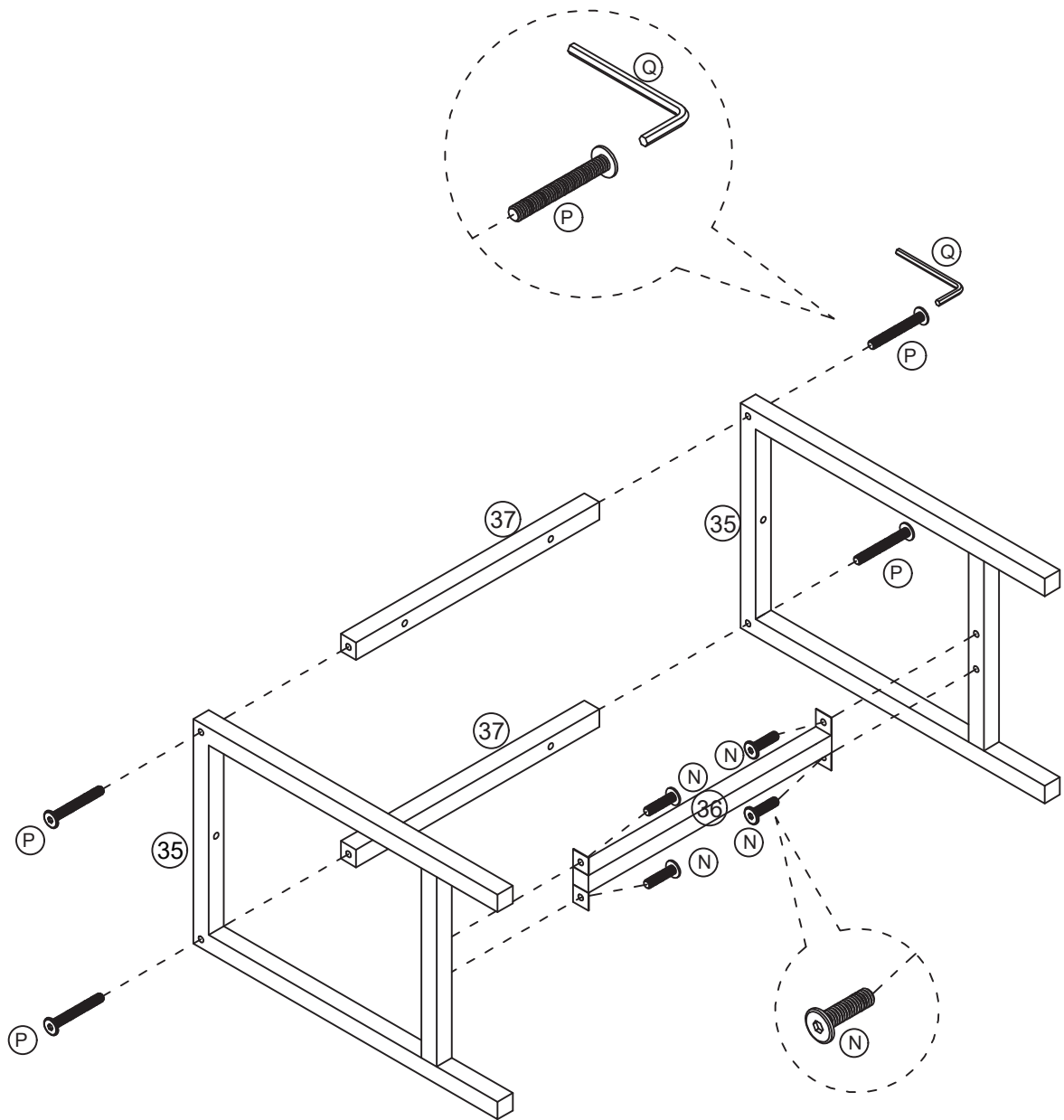
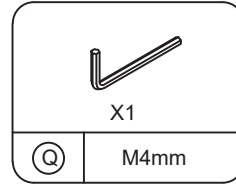
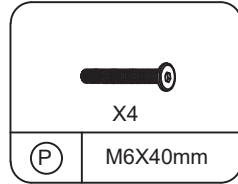
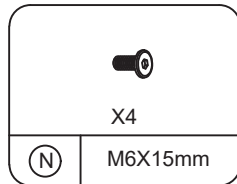

step 57

