



**INSTRUCTIONS D'ASSEMBLAGE
ASSEMBLY INSTRUCTIONS**

**BUREAU -
48"L / NOIR / DESSUS GRIS**

**COMPUTER DESK -
48"L / BLACK / GREY TOP**



**POUR DE L'ASSISTANCE OU POUR COMMANDER
DES PIÈCES CONTACTEZ NOTRE DÉPARTEMENT
DE SERVICE À LA CLIENTÈLE.**

**FOR ASSISTANCE OR TO ORDER PARTS
CONTACT OUR CUSTOMER SERVICE DEPARTMENT**

LISTE DES PIÈCES PARTS LIST

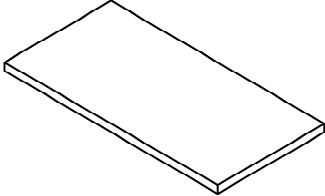
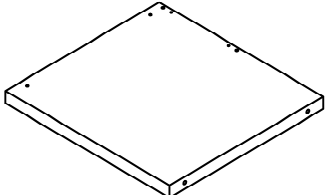
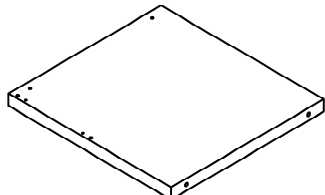
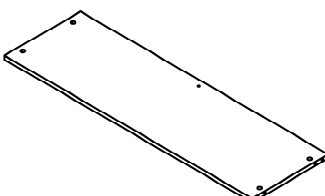
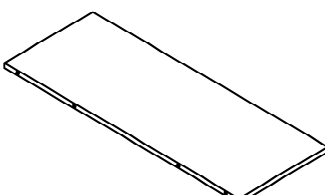
PIÈCE / PART #	IMAGE	DESCRIPTION	QTY / QTÉ
1		DESK TOP SURFACE DU BUREAU	1
2		FRONT FACING LEFT SIDE PANEL PANNEAU DE CÔTÉ GAUCHE	1
3		FRONT FACING RIGHT SIDE PANEL PANNEAU DE CÔTÉ AVANT DROIT	1
4		BACK PANEL PANNEAU ARRIÈRE	1
5		KEYBOARD TRAY PLATEAU A CLAVIER	1

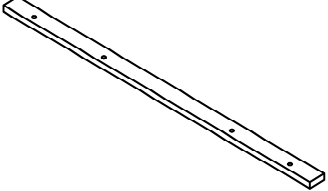
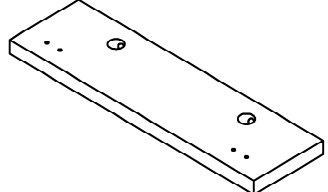
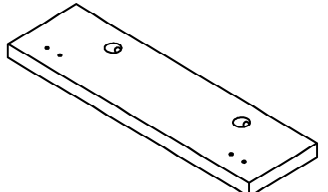

LISTE DES PIÈCES
PARTS LIST

PIÈCE / PART #	IMAGE	DESCRIPTION	QTY / QTÉ
6		CROSSBAR BARRE TRANSVERSALE	1
7		KEYBOARD TRAY HOLDER SUPPORT DE PLATEAU A CLAVIER	1
8		KEYBOARD TRAY HOLDER SUPPORT DE PLATEAU A CLAVIER	1

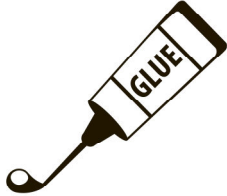
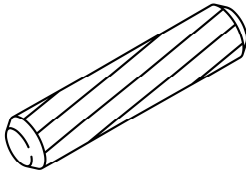
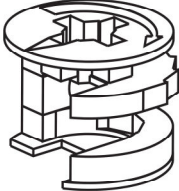
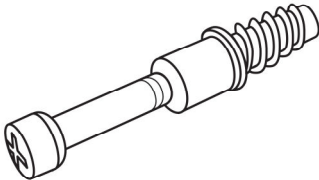
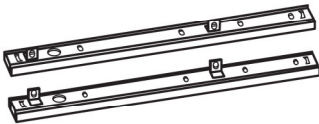

LISTE DES PIÈCES DE MONTAGE HARDWARE LIST

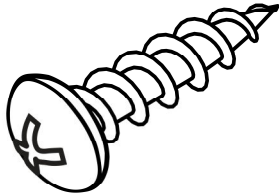
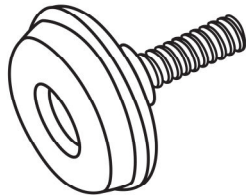
PIÈCE / PART #	IMAGE	DESCRIPTION	QTY / QTÉ
A		GLUE COLLE	1
B		WOOD DOWEL - Ø3/8" X 1 1/8" GOUJON DE BOIS - Ø3/8" X 1 1/8"	12
C		CAM LOCK CONNECTOR - Ø5/8" X 1/2" ÉCROU CAM LOCK - Ø5/8" X 1/2"	8
D		CAM LOCK SCREW - 1 3/8" VIS CAM LOCK - 1 3/8"	8
E		METAL KEYBOARD SLIDE - 11 7/8" COULISSE DE MÉTAL POUR CLAVIER - 11 7/8"	1

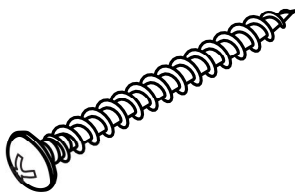
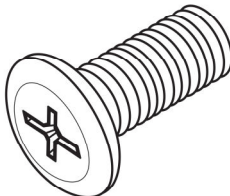
LISTE DES PIÈCES DE MONTAGE
HARDWARE LIST

PIÈCE / PART #	IMAGE	DESCRIPTION	QTY / QTÉ
F		<p align="center">ASSEMBLING SCREW - 5/8"</p> <p align="center">VIS D'ASSEMBLAGE - 5/8"</p>	12
G		<p align="center">ADJUSTABLE LEG - 1 5/8"</p> <p align="center">PATTE AJUSTABLE - 1 5/8"</p>	4
H		<p align="center">SUPPORT - 2 5/8"</p> <p align="center">SUPPORT - 2 5/8"</p>	5
I		<p align="center">ASSEMBLING SCREW - 1 1/8"</p> <p align="center">VIS D'ASSEMBLAGE - 1 1/8"</p>	10
J		<p align="center">ASSEMBLING BOLT - 5/8"</p> <p align="center">BOULON D'ASSEMBLAGE - 5/8"</p>	5

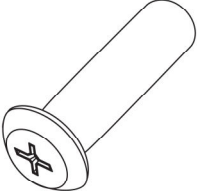
LISTE DES PIÈCES DE MONTAGE HARDWARE LIST

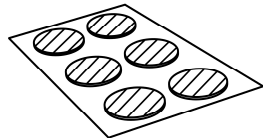
PIÈCE / PART #	IMAGE	DESCRIPTION	QTY / QTÉ
K		BARREL NUT - Ø1/4" X 1 7/8" ÉCROU DE CANON - Ø1/4" X 1 7/8"	4
L		BARREL NUT - Ø1/4" X 3/4" ÉCROU DE CANON - Ø1/4" X 3/4"	1
M		FINISHING STICKER - Ø3/4" COLLANT DE FINITION - Ø3/4"	8

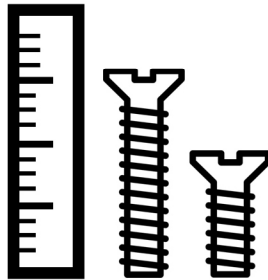

OUTIL DE VÉRIFICATION DE DIMENSIONS DES PIÈCES
HARDWARE DIMENSIONS VERIFICATION TOOL

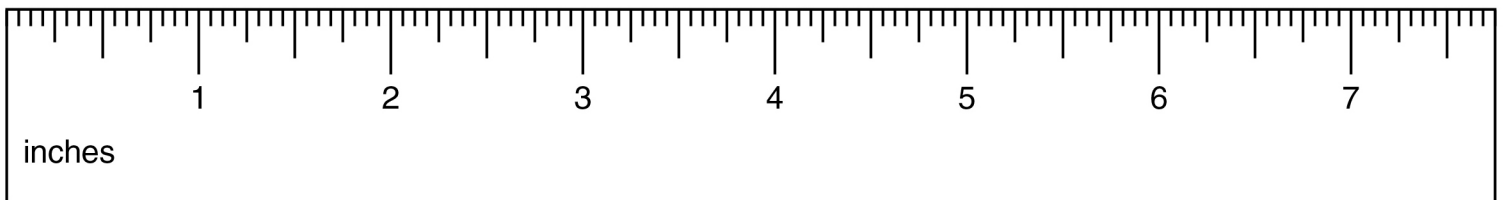

ÉTAPE / STEP 1

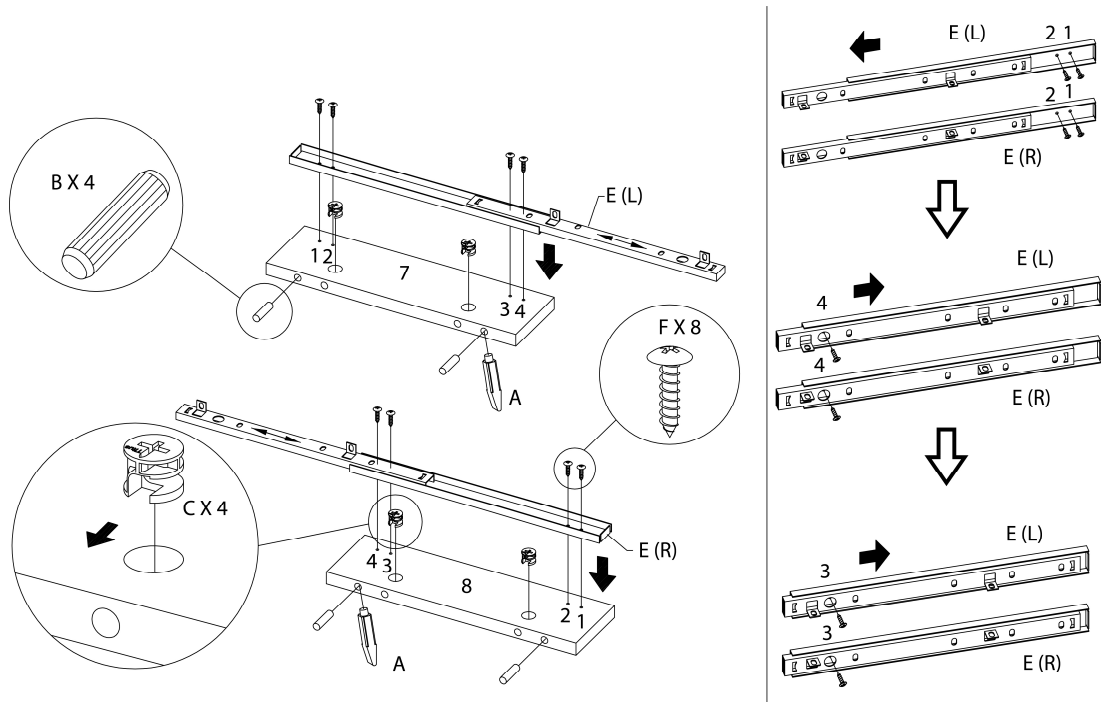

ÉTAPE / STEP 2

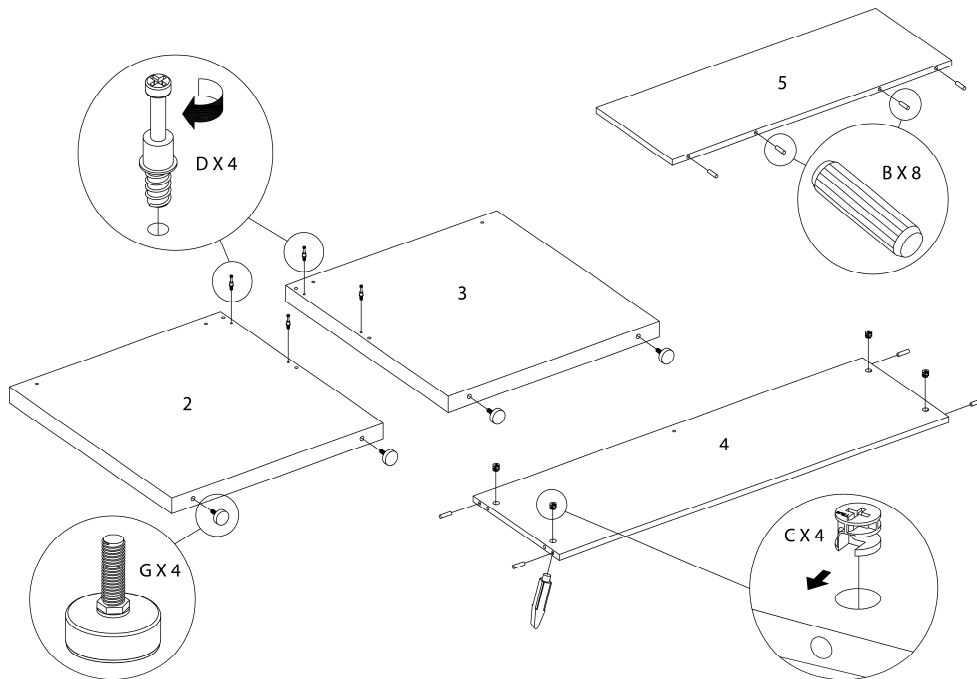

ÉTAPE / STEP 3

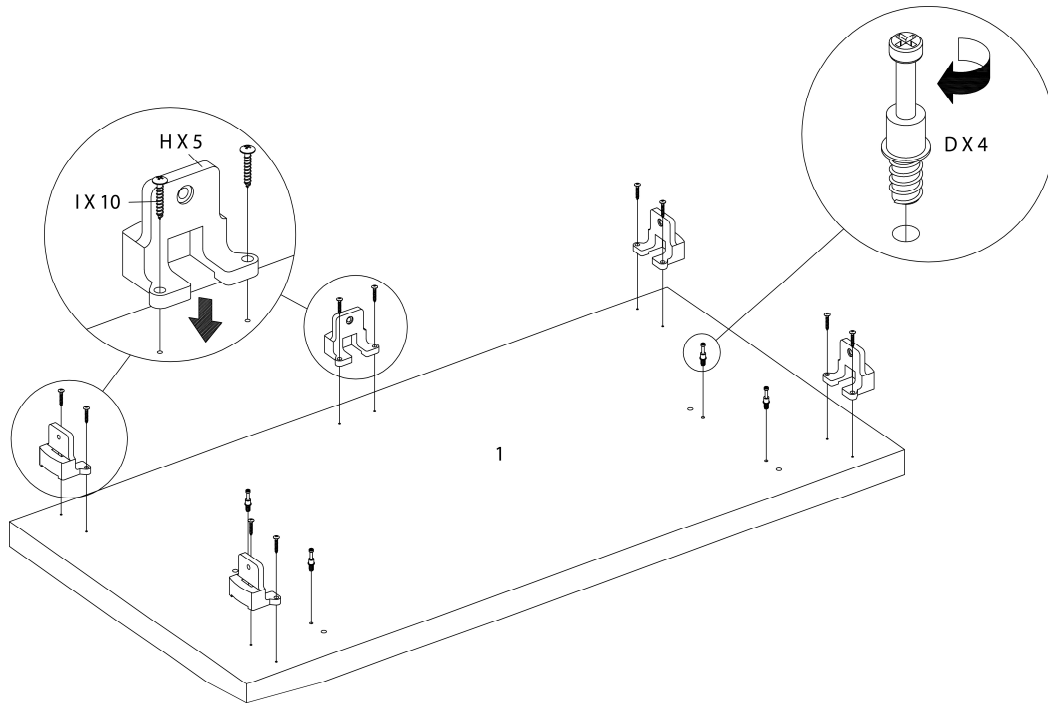

ÉTAPE / STEP 4

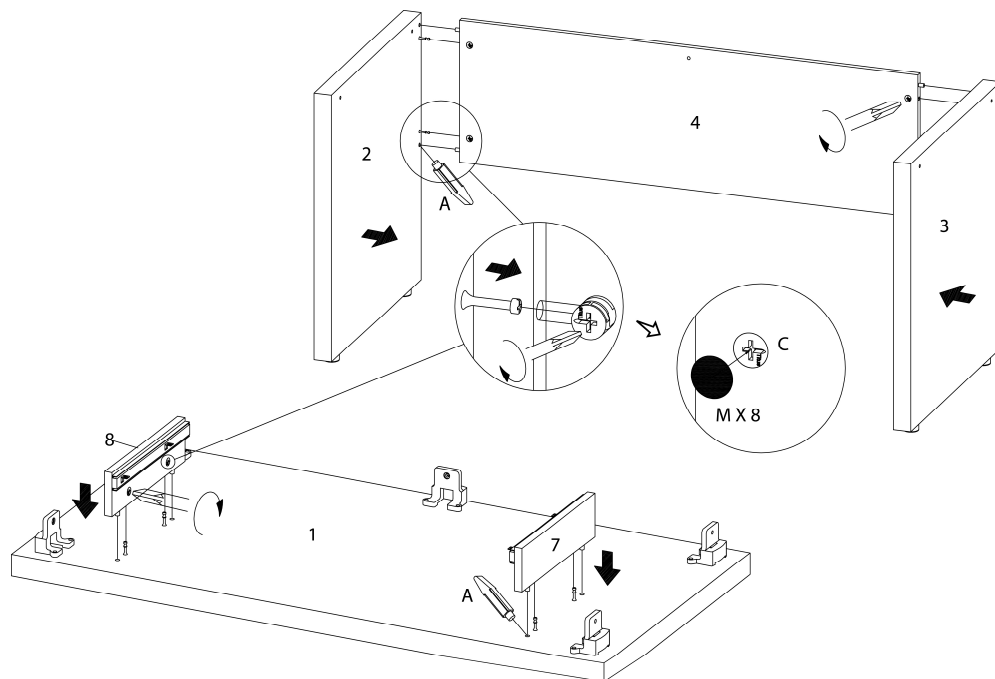

ÉTAPE / STEP 5

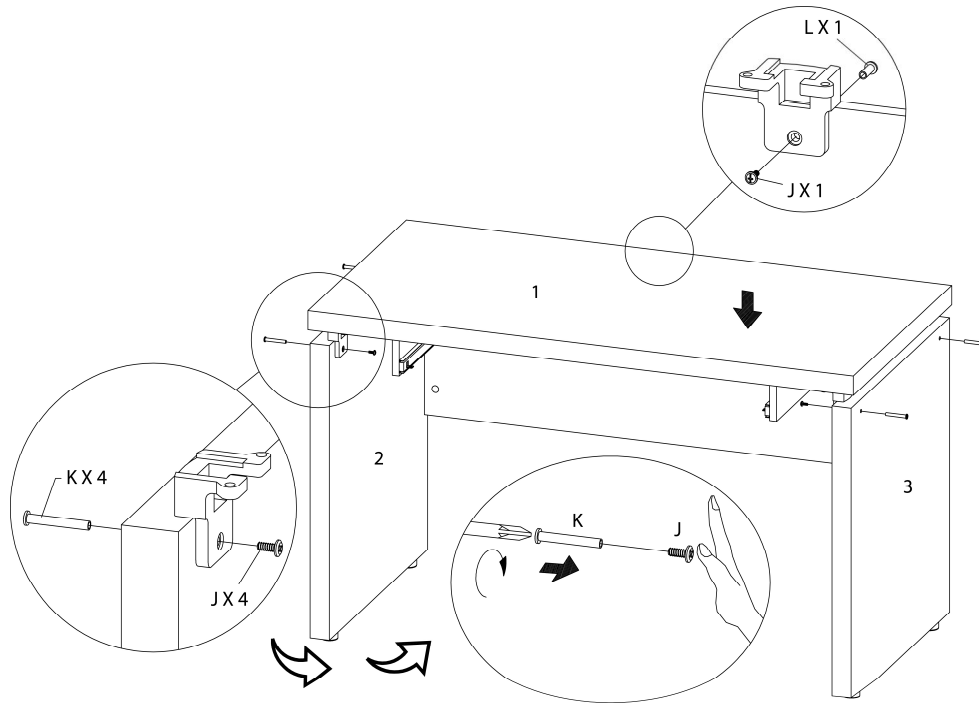

ÉTAPE / STEP 6

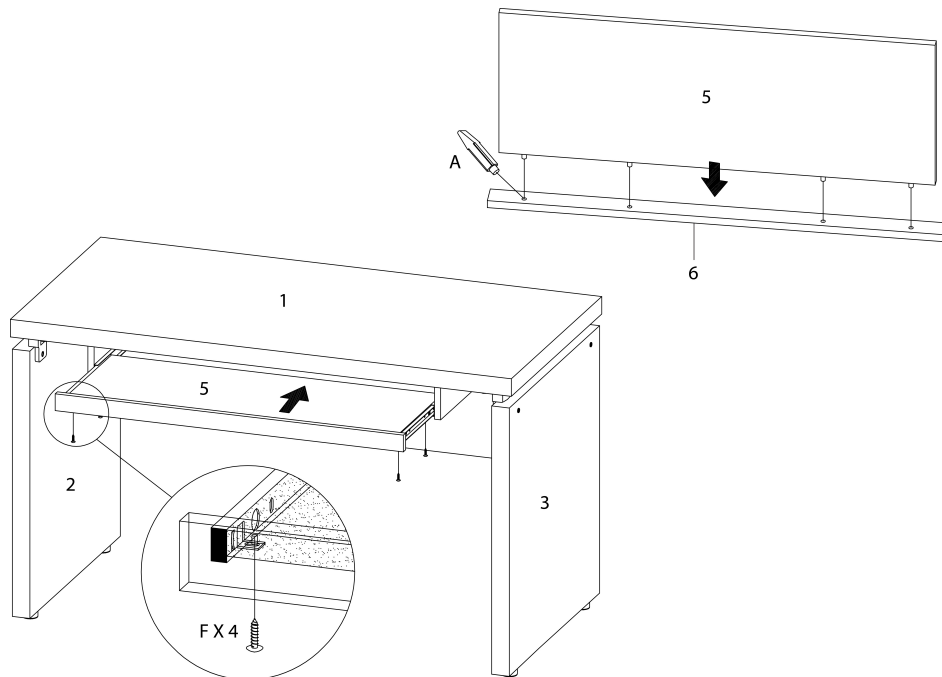

ÉTAPE / STEP 7

