

ASSEMBLY INSTRUCTION & PART IDENTIFICATION MODEL

Thank you for purchasing this quality product. Be Sure to check all packing material carefully parts that may have come loose inside the carton during shipment

| Parts key | | | | | | | |
|-----------|------|------|---------------------------|----|-------|-------|---------------------|
| No | Code | Qty | Description | No | Code | Qty | Description |
| 1 | P07R | 3pc | Right Side Facing Door | 6 | P04 | 6sets | Door Handle w/Screw |
| 2 | P07L | 3pc | Left Side Facing Door | 7 | P07H | 12pc | Door Hinge |
| 3 | P08R | 1pc | Shelf - Right Side Facing | 8 | P01D | 6pc | Door Catch |
| 4 | P08L | 1pcs | Shelf - Left Side Facing | 9 | P01F | 4pc | Floor Glide |
| 5 | P08C | 1pcs | Shelf - Center | 10 | P01AT | 2sets | Anti Tip Kit |

| Anti Tip Kit | | | | | |
|--------------|-----|---------------------|----|-----|---------------|
| No | Qty | Description | No | Qty | Description |
| A | 4pc | Plastic Wall Anchor | D | 4pc | Short Screw |
| B | 4pc | Plastic bracket | E | 2pc | Plastic strap |
| C | 4pc | Long Screw | | | |

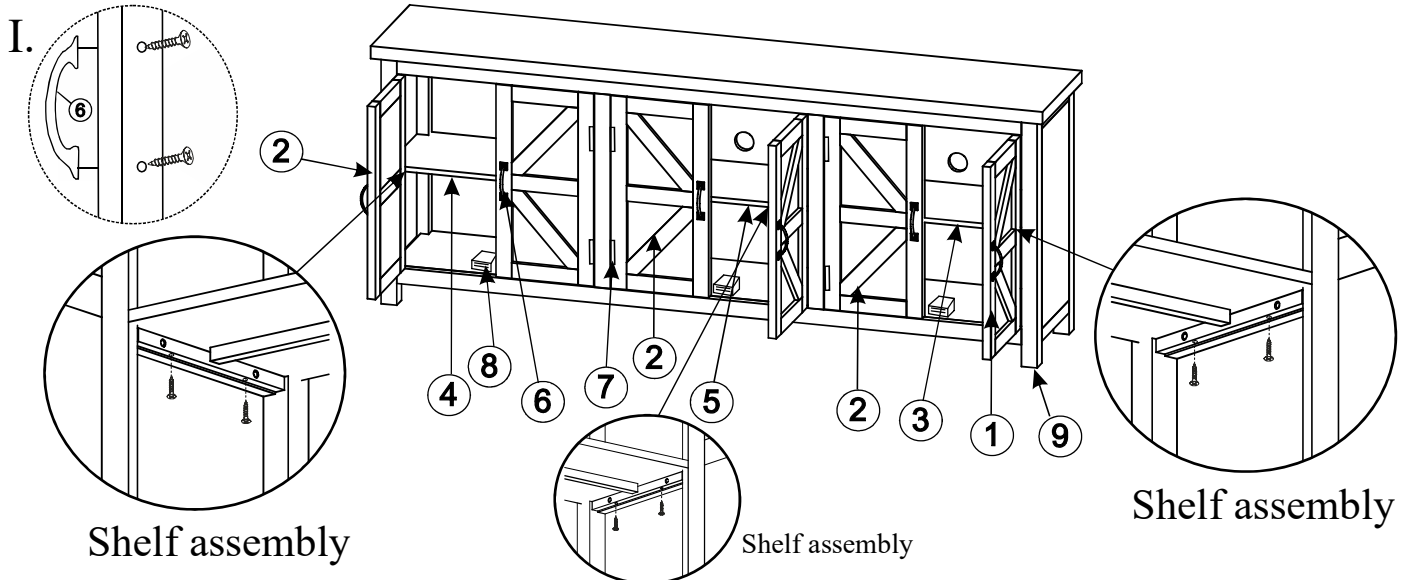

PLEASE NOTE : To help prevent the possibility of tip-over, install the tipover restraint provided.

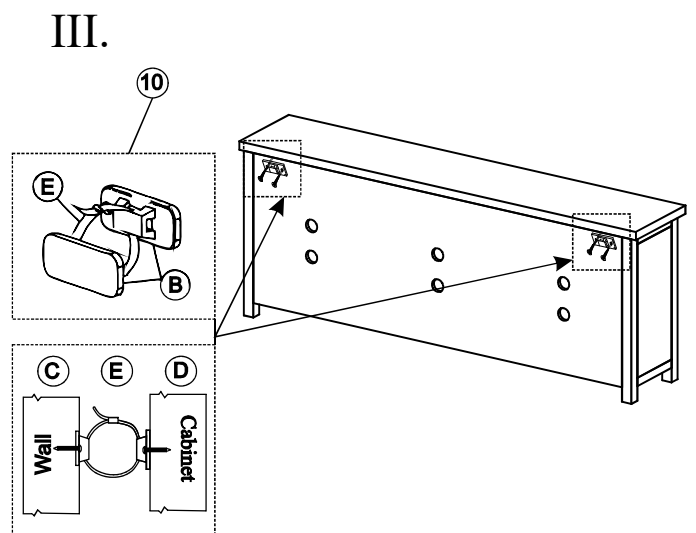
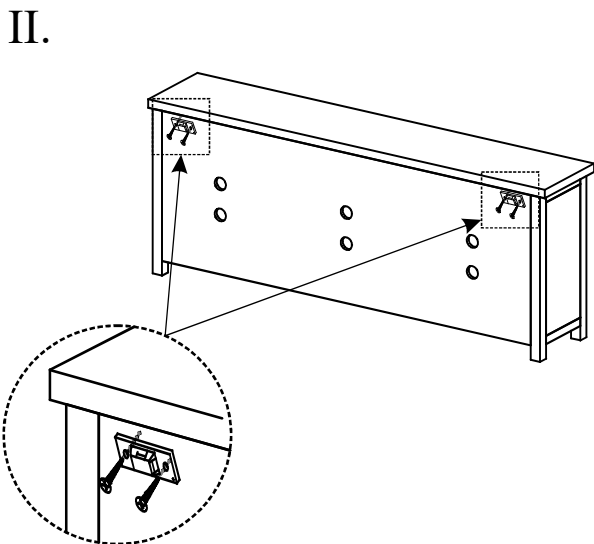

Made in India