

STAINLESS STEEL WORK TABLE

Assembly Instruction









NOTE:

To continuously improve its products, VIVOHOME reserves the right to modify this information without prior notification. For any questions regarding assembly, please watch the video on the product page or contact our customer service. Our customer service will gladly assist you with any additional questions, comments, or concerns. Thank you for using VIVOHOME products in your home!

Thank You For Purchasing From
VIVOHOME
MADE IN CHINA

Parts List and Diagram

Before assembling the product, ensure that your package has the following parts. If any of the parts are missing or defective, please contact customer service for help.

| | | | |
|--|--|---|---|
| <p>Table leg tube</p>  <p>4 pcs A</p> | <p>Table board</p>  <p>1 pc B</p> | <p>Supporting layer</p>  <p>1 pc C</p> | |
| <p>Screws</p>  <p>4 pcs D</p> | <p>Wrench</p>  <p>1 pc E</p> | <p>Foot nails</p>  <p>4 pcs F</p> | <p>Universal wheel</p>  <p>4 pcs G</p> |

Assemble steps

Step 1

Using a tape measurer or another measuring tool we will mark where Part C (the support layer) will be on all 4 Part A's (the table legs). These marks should all be the same distance from the end of the table leg (Part A). Make the marks according to your preferred position.

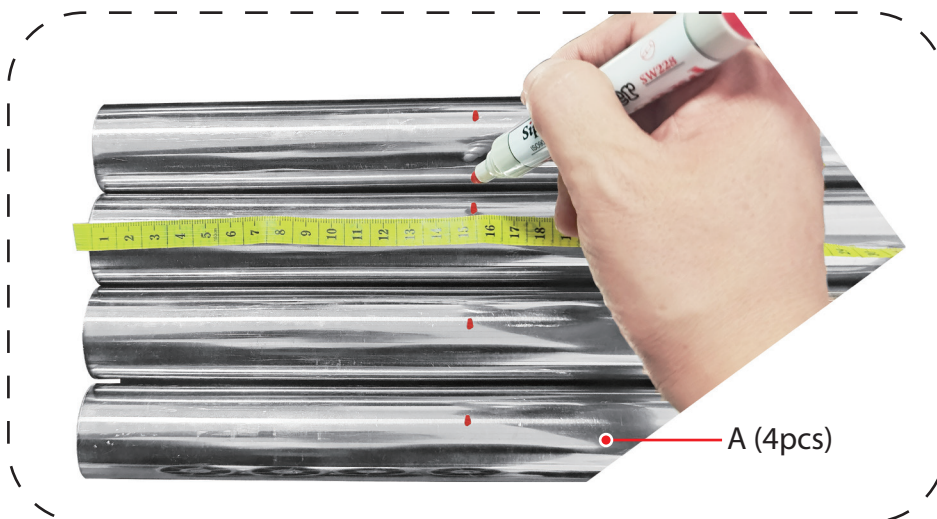

Assemble steps

Step 2

Tighten the four Part A leg tubes as shown in the picture.

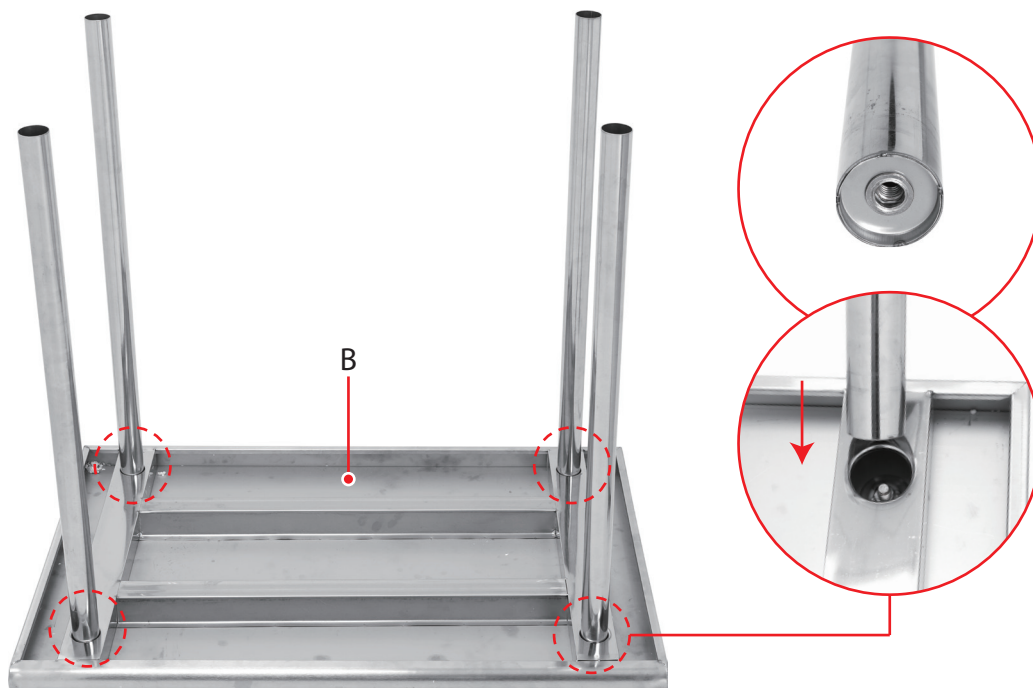

Step 3

Put the Part C supporting layer into the Part A table leg tubes, align the marks drawn before, and tighten the Part D screws.

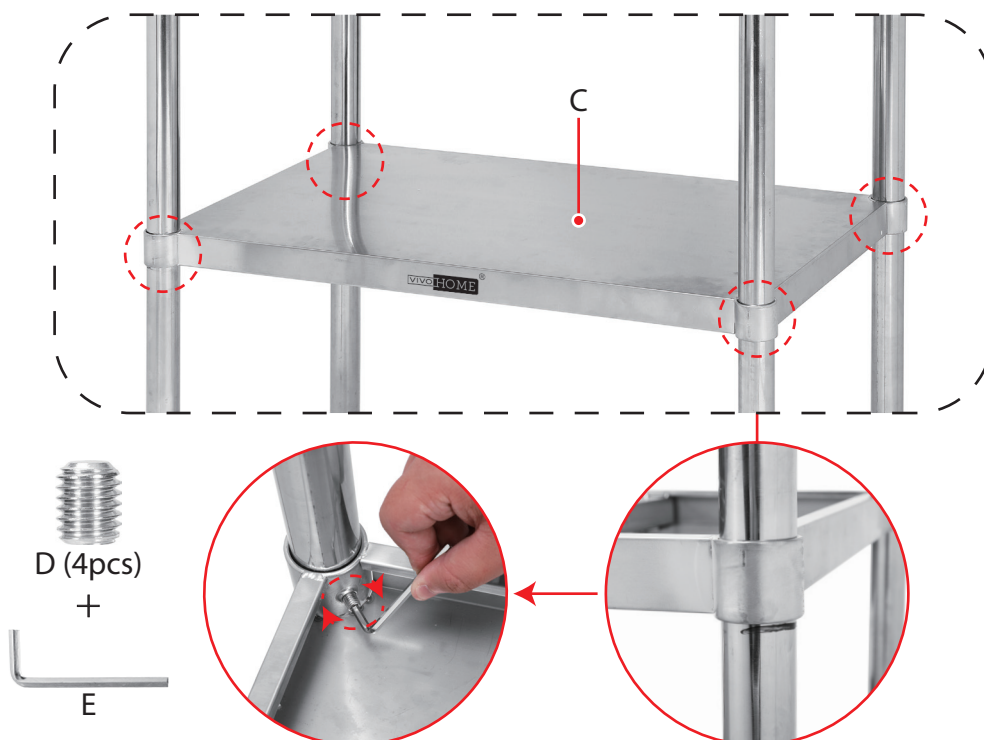

Assemble steps

Step 4

Use a rubber hammer (not included) to knock the four Part F foot nails into the Part A table leg tubes. (Be sure to hit the end.)



Note: The product is equipped with four universal wheels with brakes. If you want to use the universal wheels, you can unscrew the metal foot pads of the Part F foot nails, screw on the universal wheels and tighten them.

