

# Assembly Instructions

**Caution: You must read this before you proceed**

## CHAIR

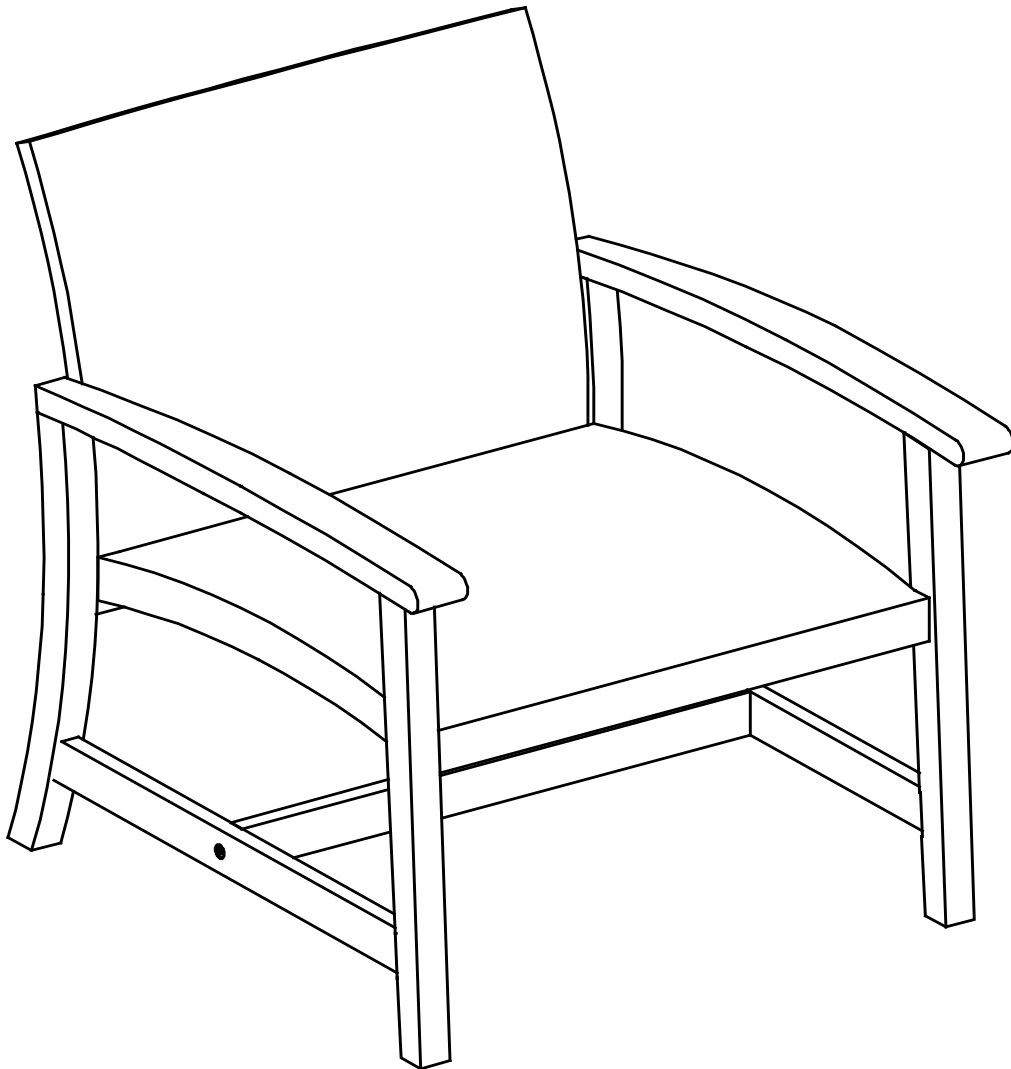

**CAUTION:** This Chair is NOT a TOY.



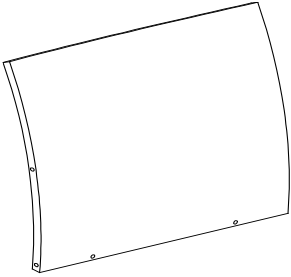
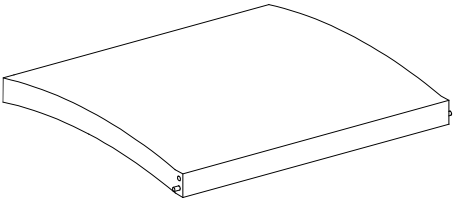
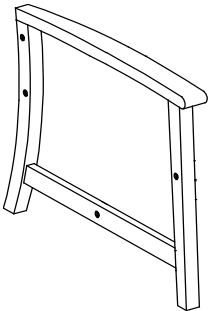
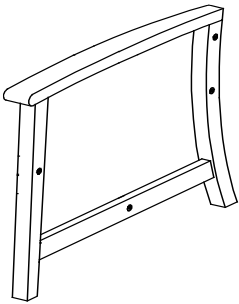
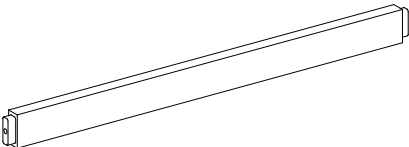

Keep your child / children at bay during the assembly process of assembly.

For turning the Chair and to prevent damage to the Chair, 02 persons may be needed to execute this action

# Parts List

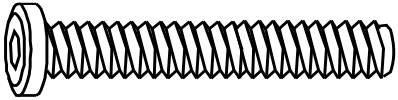
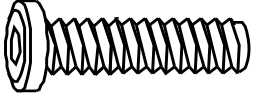
Label	Picture	Description	QTY
A	 A curved rectangular panel with four small circular holes, one near each corner, for assembly.	Backrest panel	1
B	 A rectangular panel with a slight upward curve on the front edge and four small circular holes, one near each corner.	Seat Panel	1
C	 A wooden frame component consisting of a vertical leg, a horizontal base, and a curved backrest support, with four small circular holes for assembly.	Right Leg Panel (with Leveler)	1
D	 A wooden frame component consisting of a vertical leg, a horizontal base, and a curved backrest support, with four small circular holes for assembly.	Left Leg Panel (with Leveler)	1
E	 A long, thin rectangular bar with a slightly raised profile and a small notch at one end.	Leg Support Bar	1

# Hardware

Label	Picture	Description	QTY
①		Bolt (M8x55mm)	7
②		Bolt (M8x25mm)	3
③		Screw (M7x60mm)	3
④		Flat Washer (M8/18x1.5mm)	3
⑤		Allen Key	2

# Assembly Preparation

Before Beginning Assembly:

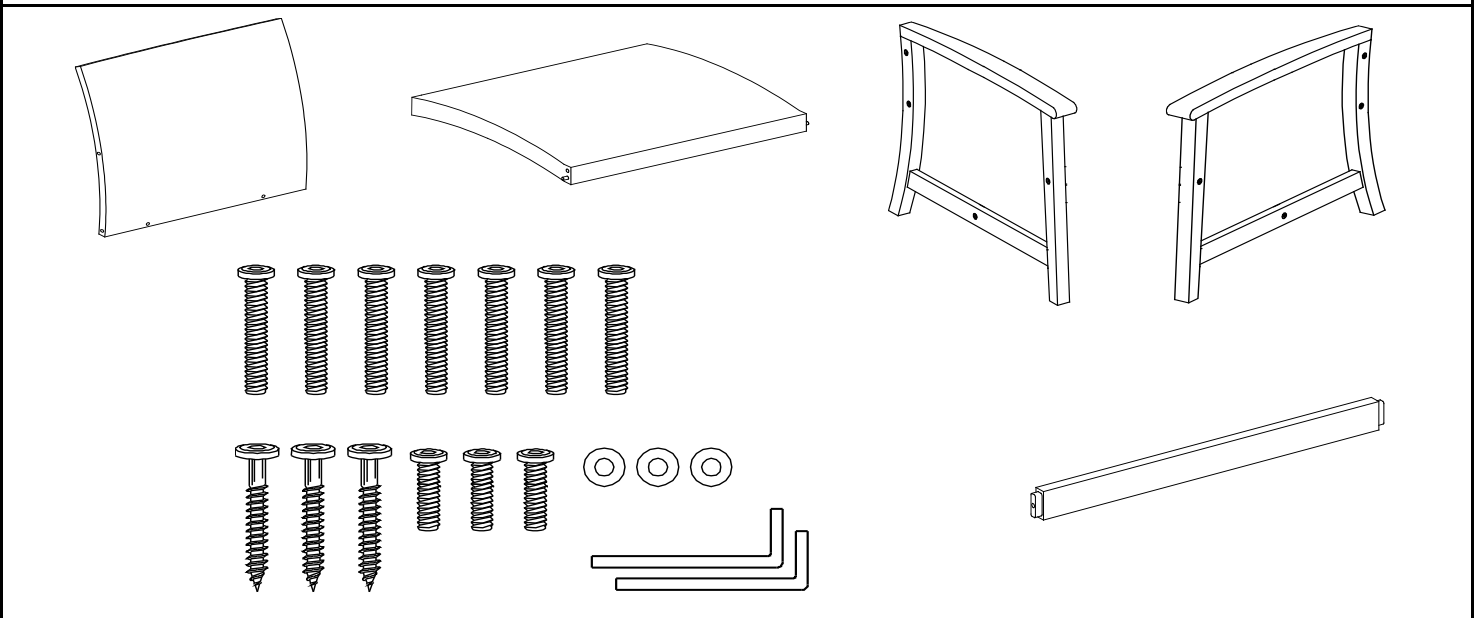

- Read instructions, cover to cover-



- Have 2 adults on hand for assembly-



- Do not assemble on flooring or carpet-



- Assemble on a clean non-marring surface (packing foam)-



- Save all packaging until finished-

# Assembly Steps

## Overview

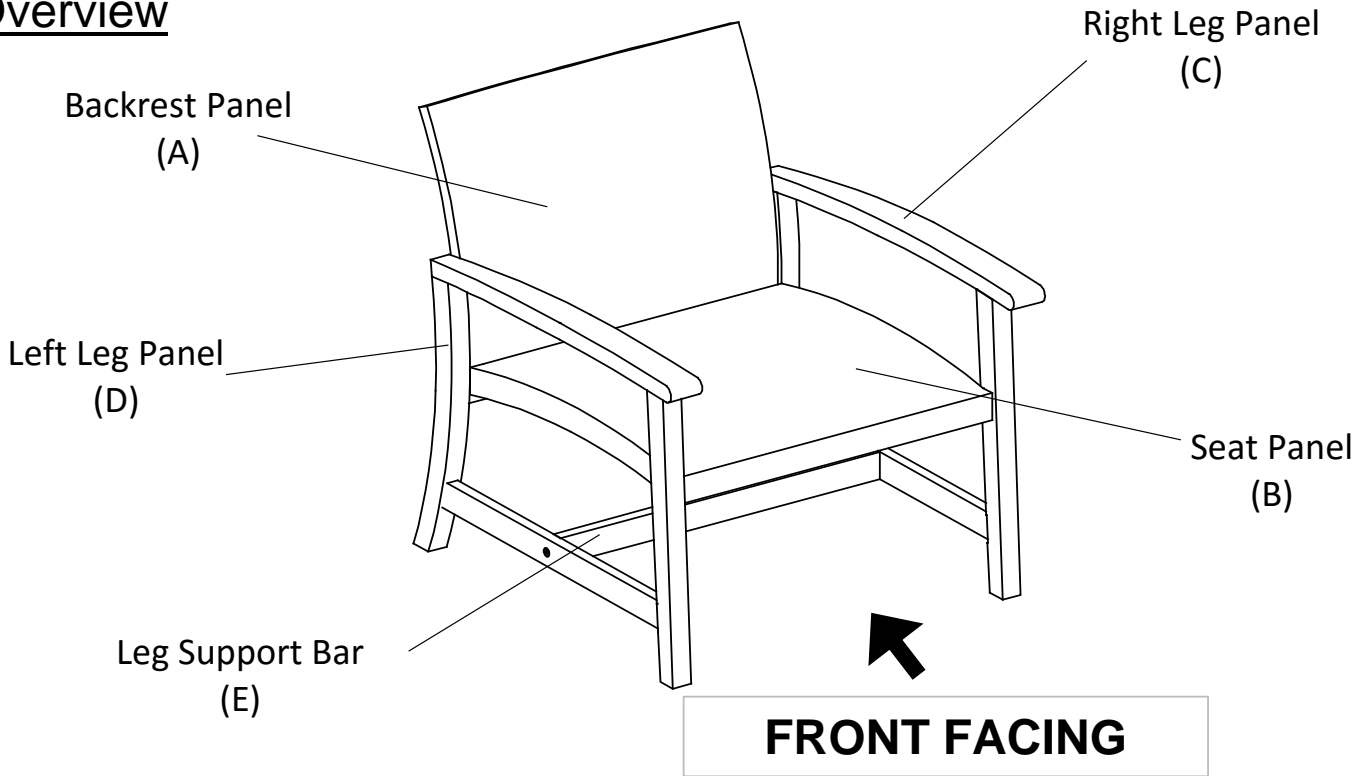

This Chair has multiple parts and may require up to 30 minutes to assemble. To give you an overview of the Chair parts, the above picture is to help you put the various parts into perspective. Please read through the instructions below to familiarise yourself with the parts and steps before assembly.

## Step 1

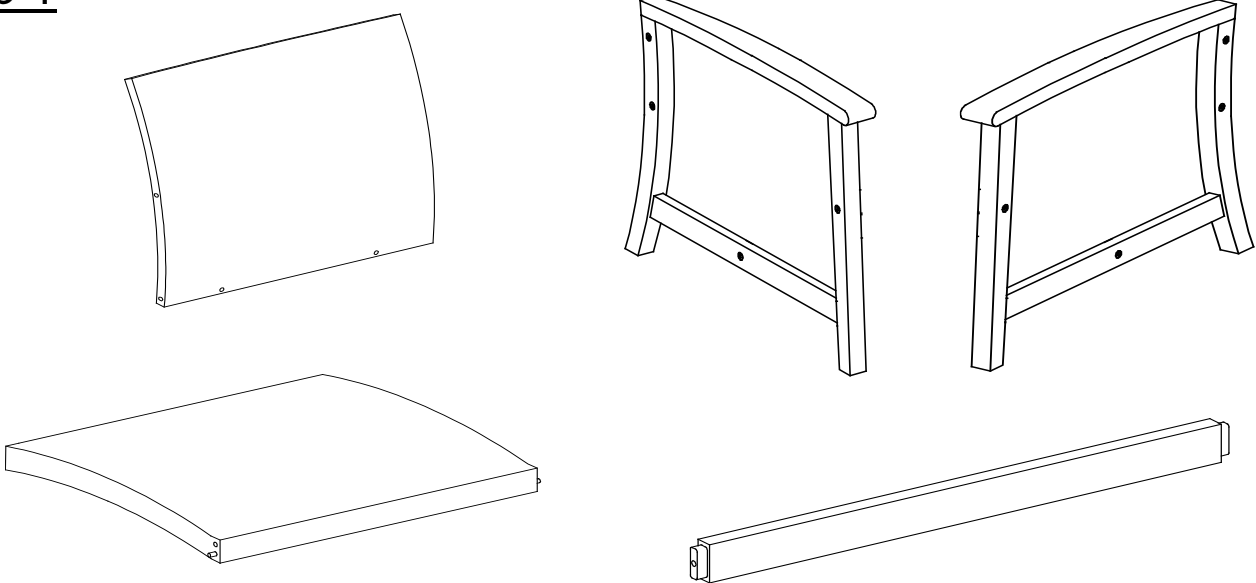

Unpack and place all parts on a clean, non-marring surface.

## Step 2

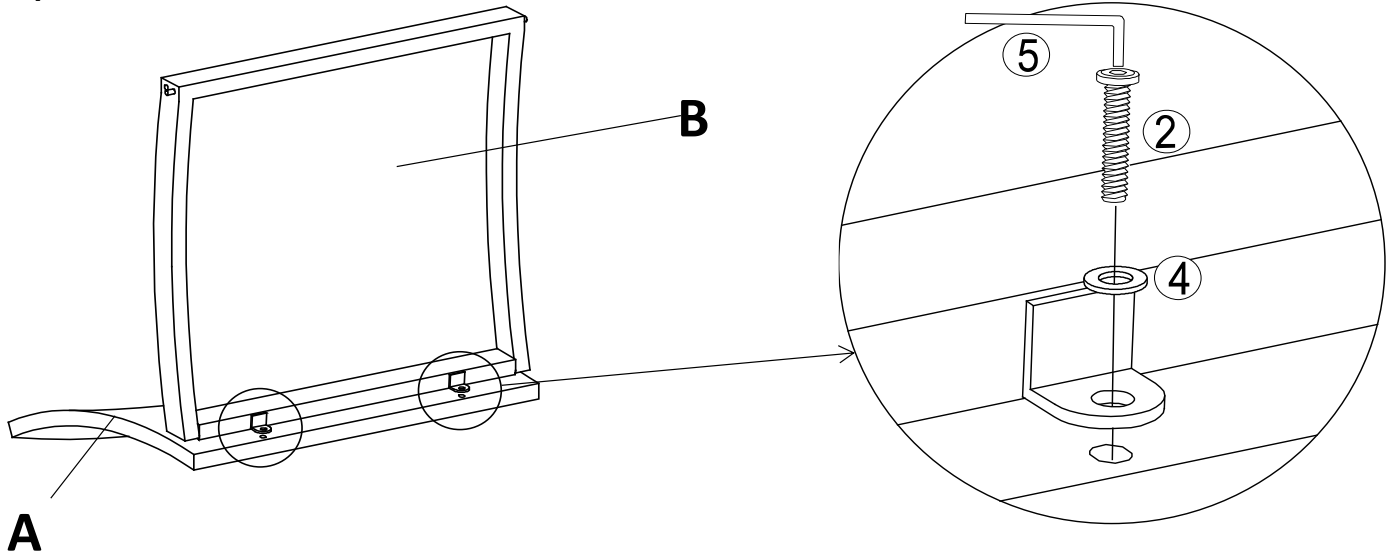

Lay down Backrest Panel (A) then attach Seat Panel (B) to Backrest Panel (A) by using Bolts (②), Flat Washer (④) and secure by Allen key (⑤).

**Do not fully tighten the Bolts.**

## Step 3

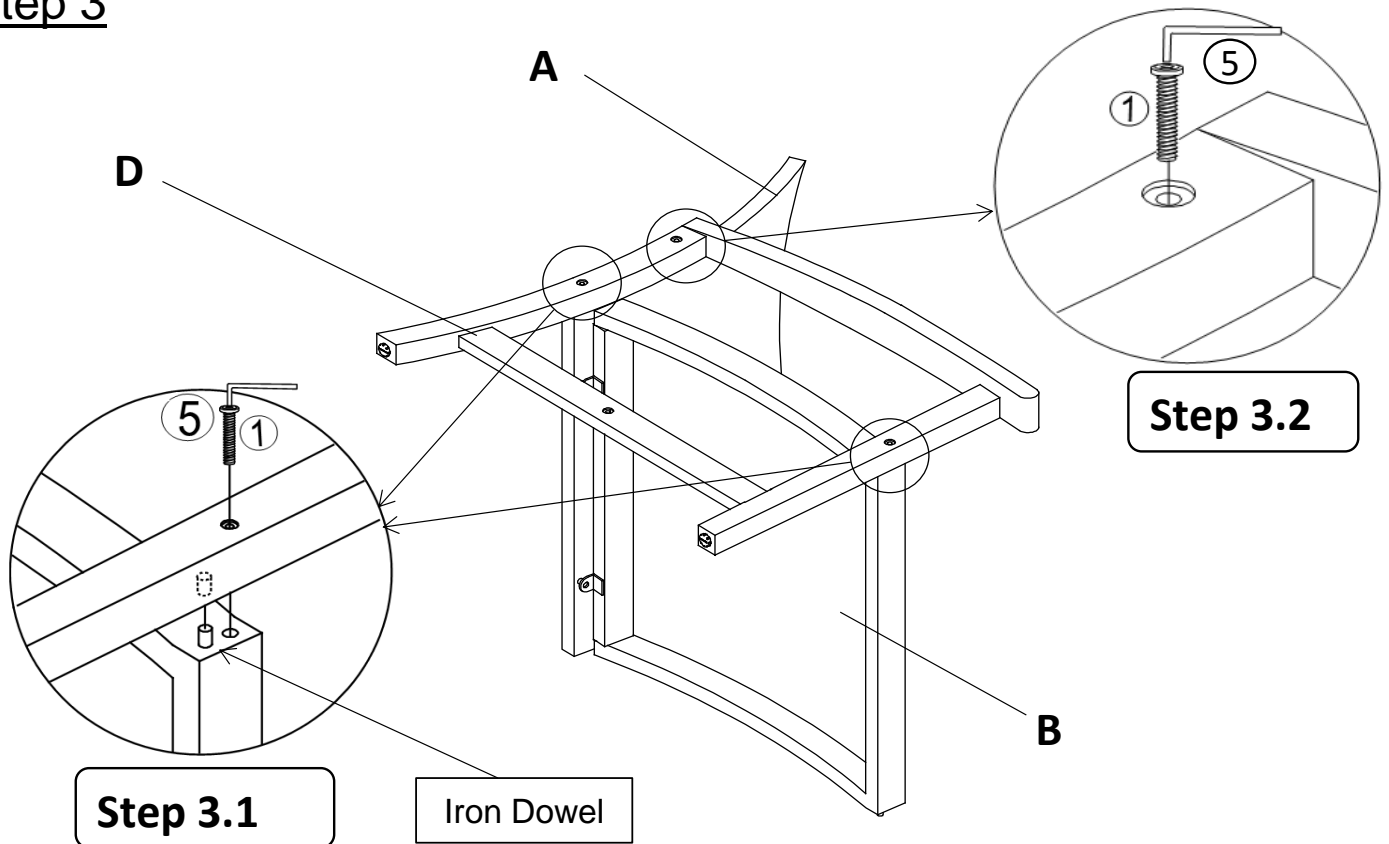

Position housing of Left Leg Panel (D) into pre-fixed iron dowel on Seat Panel (B) as picture above.

Step 3.1: Secure Left Leg Panel (D) to Seat Panel (B) by using Bolt (①) with Allen Key (⑤)

Step 3.2: Secure Left Leg Panel (D) to Backrest Panel (A) by using Bolt (①) with Allen Key (⑤)

**Do not fully tighten the Bolts.**

## Step 4

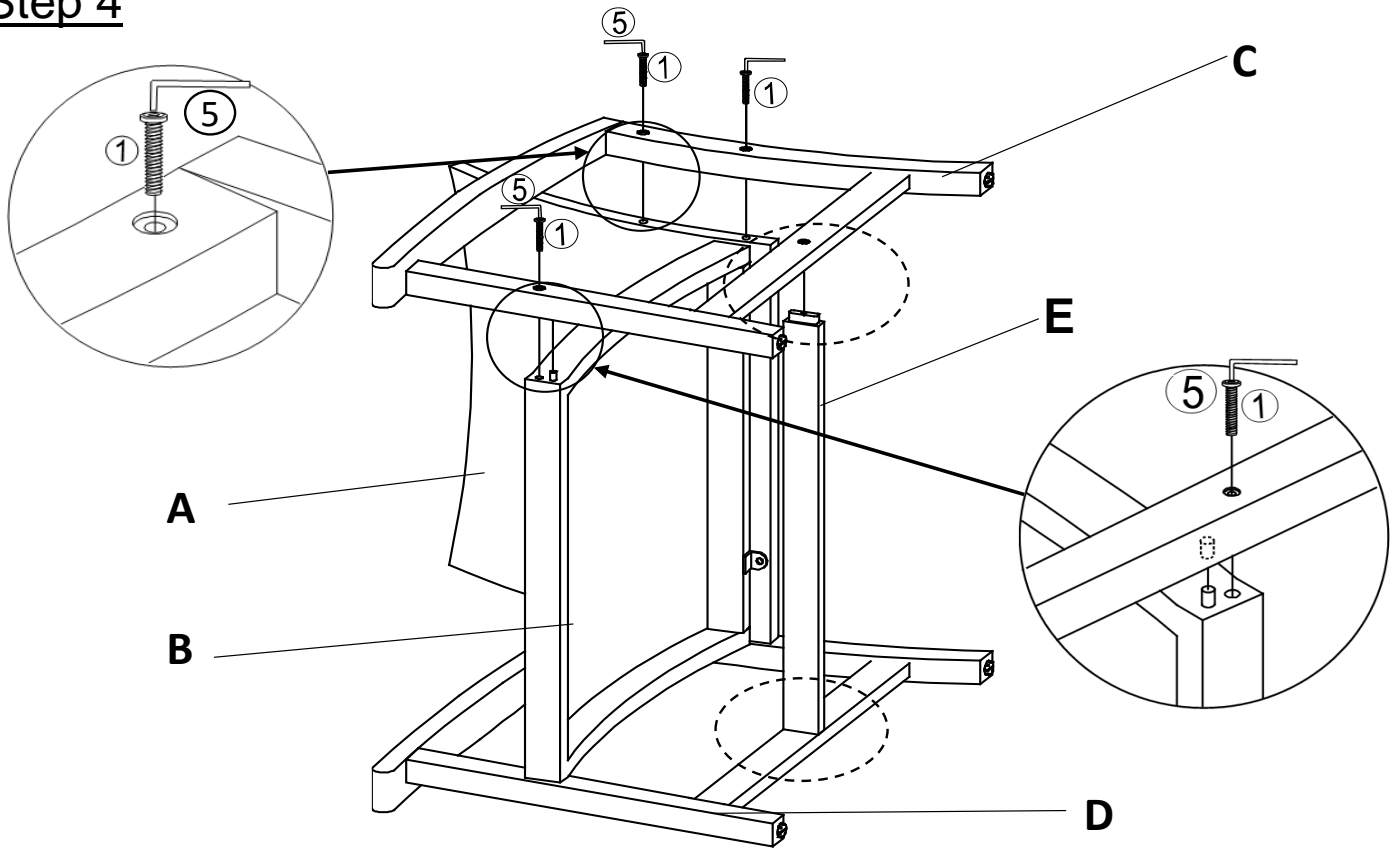

With assistance from your adult partners, turn the pre-assembled part in step 3 to the other side.

Align the Tenon of Leg Support Bar(E) into the Mortise of Left Leg Panel(D). Then position Mortise of Right Leg Panel(D) onto Tenon of Leg Support Bar(E) as shown above.

Repeat same process in step 3.1 and 3.2 to Secure Right Leg Panel(C) to Seat Panel (B) and Backrest Panel (A).

**Do not fully tighten all the Bolts**

## Step 5

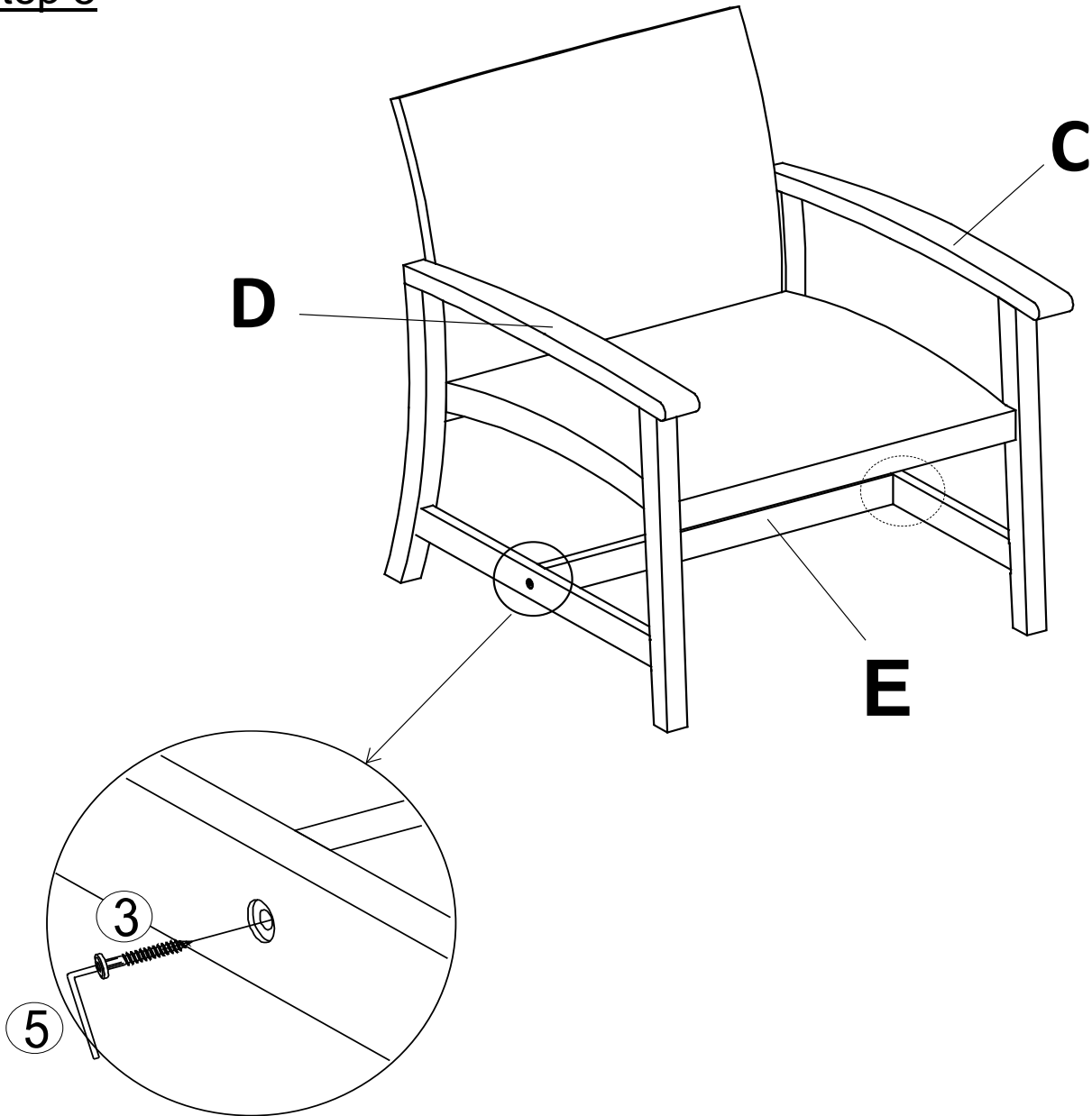

With assistance from your adult partners, turn the Chair back to normal flat ground. Secure Left Leg Panel (D) to Leg Support Bar (E) by using Screw (③) with Allen Key (⑤).

Repeat the same process to secure Right Leg Panel (C) to the remaining Leg Support Bar (E).

**Do not fully tighten the Screws.**

## Step 6

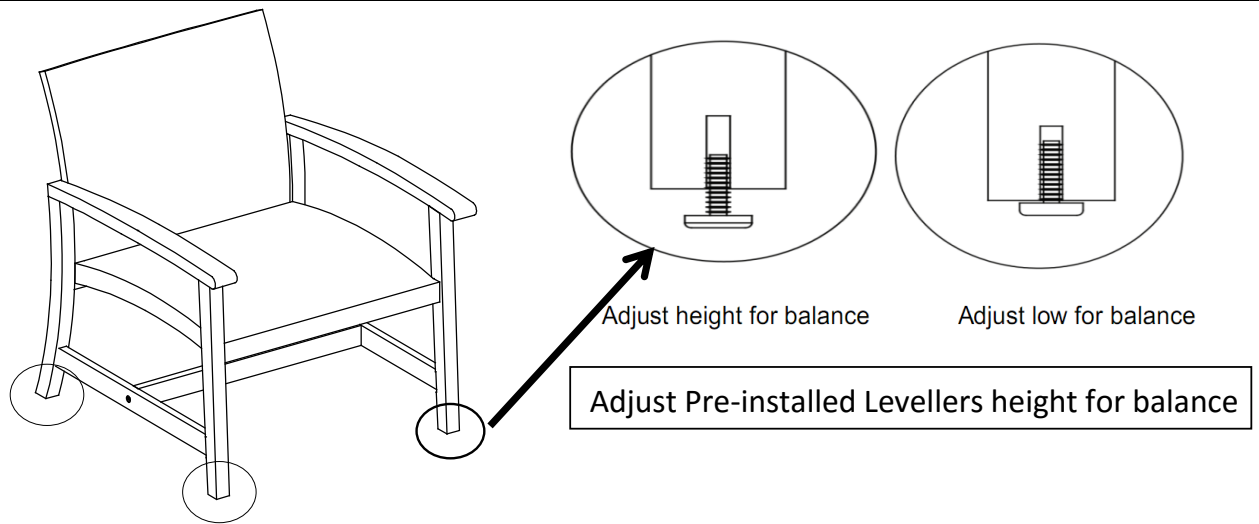

Stand the Chair up.

Place the Chair on a LEVEL surface.

Inspect it and make sure all parts are adequately connected.

Gently and gracefully, sit onto the Chair.

This pressure will help the Legs and Chair reach full alignment status.

Check for wobbles on a LEVEL surface.

If no wobbles are found proceed to tighten the Bolts and Screws in a sequential manner, until evenly secured.

**When tightening the Bolts and Screws tighten sequentially.**

**Do not tighten any Bolt or Screw fully and then move on towards the next one.**

With assistance from your adult partners, adjust the Levellers to desired height to avoid wobbles.



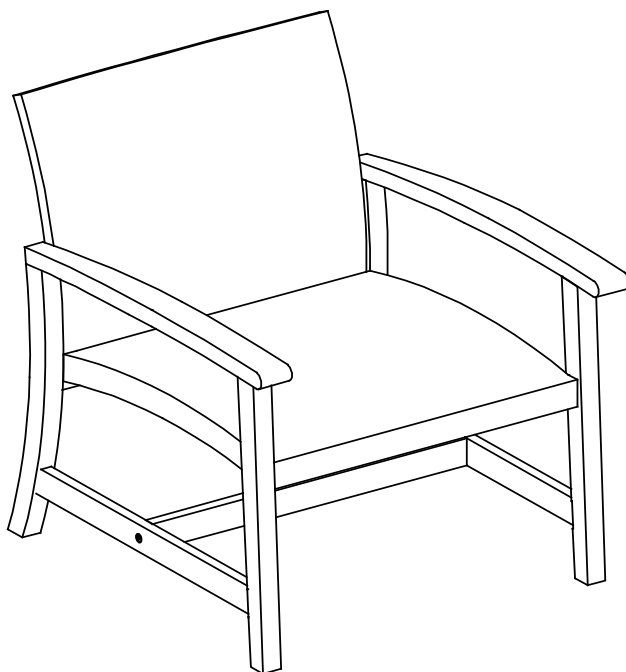

















## Step 7



Your Chair is ready for use

**This Chair can be used on a flat, level surface**

## Care & Maintenance

-   ● Do not put hot items directly on furniture surface
  -   ● Do not clean furniture with harsh cleansers or polish.
  -   ● To obtain the longest lifespan of your outdoor products, minimizing exposure to direct sunlight is recommended.
  -   ● Children should not climb or jump on the furniture.
  -   ● Do not write on furniture without a padded barrier to protect the surface.
  -   ● To obtain the longest lifespan of your outdoor products, avoid extended and lengthy exposure to rain, snow, and direct sunshine. Whenever possible cover the product and /or place under patio or awnings.
  -   ● Not for commercial use. For residential use only .
  -   ● Stains may be removed with mild soap solution and damp cloth.
  -   ● Keep away from sources of ignition.
- 
-   ● Dust and pick-up spills using a clean, non-colored, lint-free cloth.