

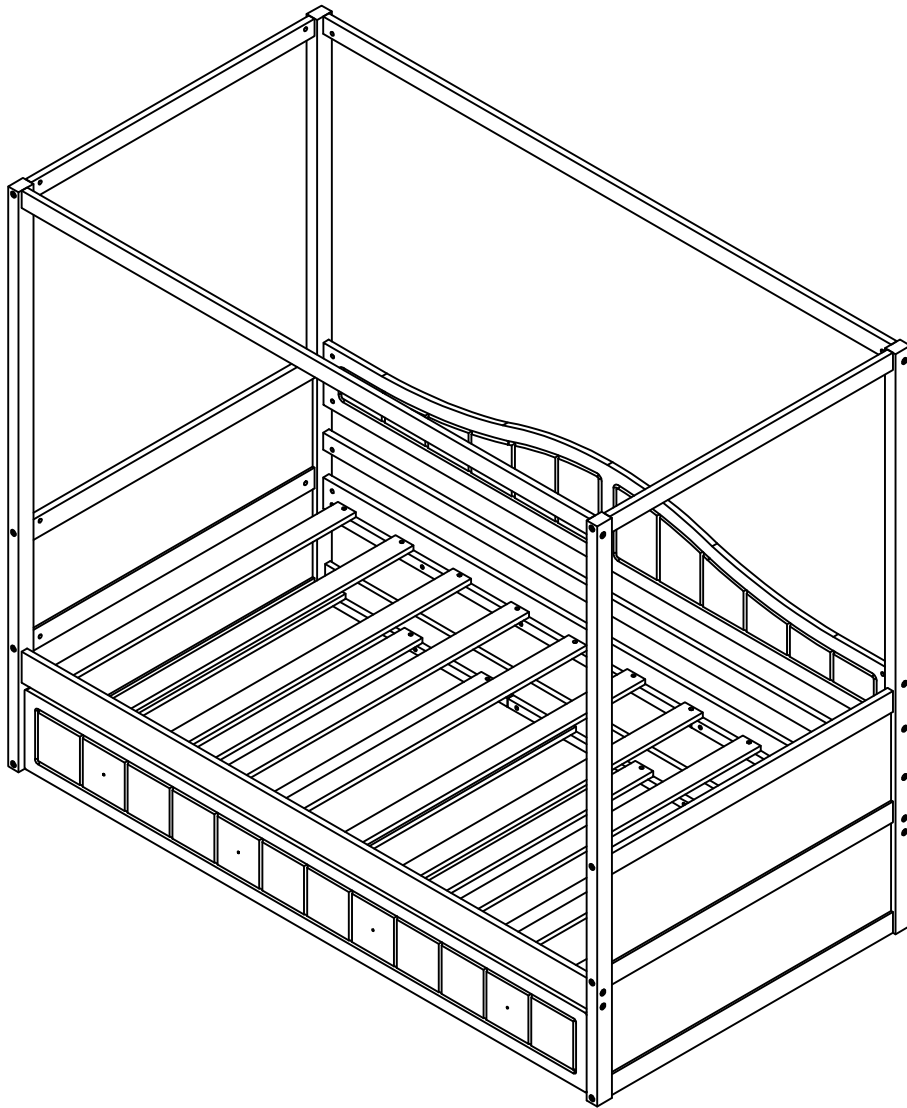

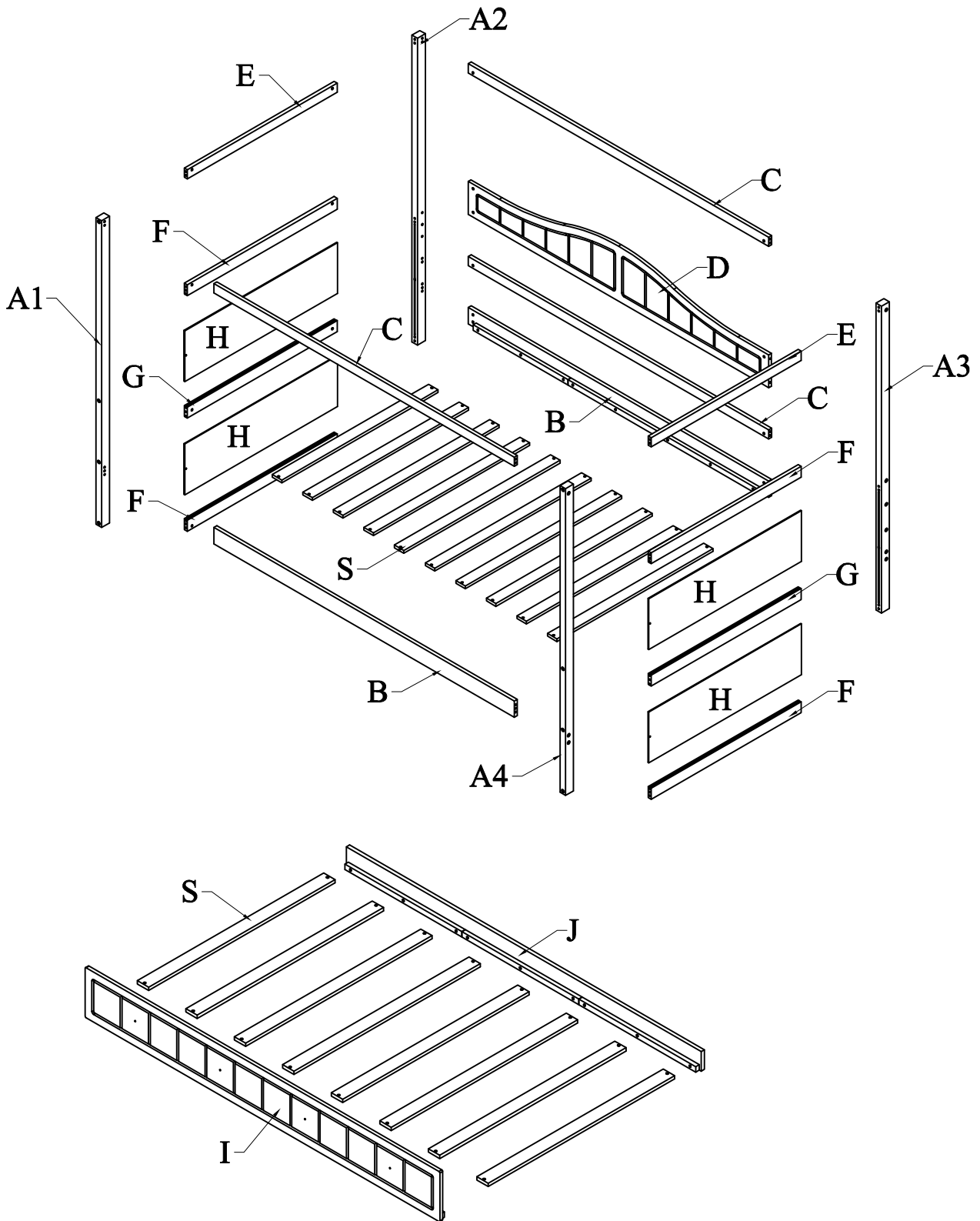

ASSEMBLY INTRUCTIONS







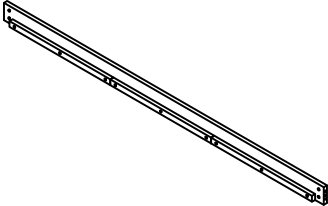
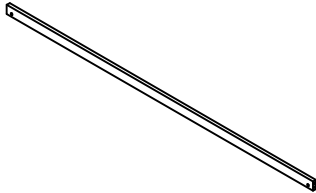
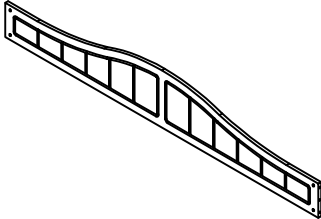
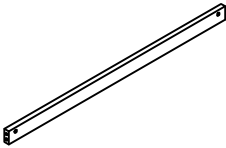
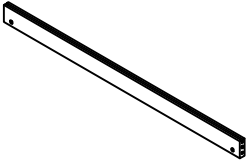
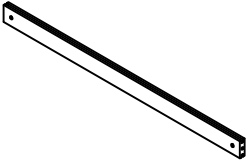
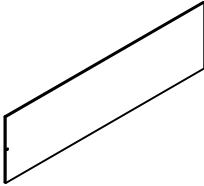
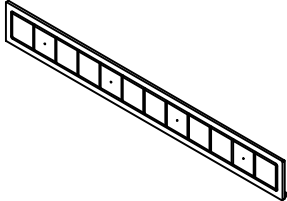
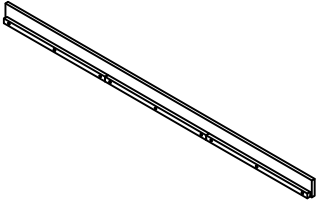
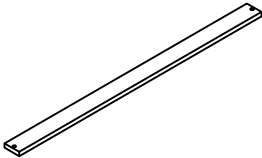

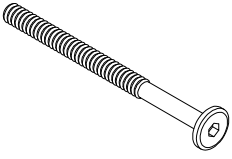
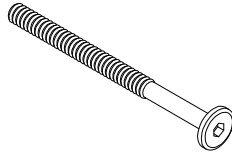

DETAIL VIEW

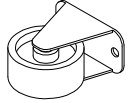
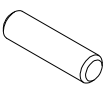

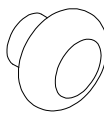
| | | | |
|--|--|--|---|
| <p>A1</p>  <p>Front leg - left (1pc)</p> | <p>A2</p>  <p>Back leg - left (1pc)</p> | <p>A3</p>  <p>Back leg - right (1pc)</p> | <p>A4</p>  <p>Front leg - right (1pc)</p> |
| <p>B</p>  <p>Side rail (2pcs)</p> | <p>C</p>  <p>Back rail (2pcs)</p> | <p>D</p>  <p>Back panel (1pc)</p> | <p>E</p>  <p>Horizontal rail - top (2pcs)</p> |
| <p>F</p>  <p>Horizontal rail - bottom (4pcs)</p> | <p>G</p>  <p>Horizontal rail - middle (2pcs)</p> | <p>H</p>  <p>Side panel (4pcs)</p> | <p>I</p>  <p>Front trundle (1pc)</p> |
| <p>J</p>  <p>Back trundle (1pc)</p> | <p>S</p>  <p>Slats (18pcs)</p> | | |

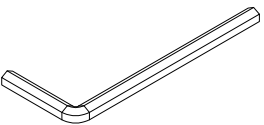
HARDWARE LIST:

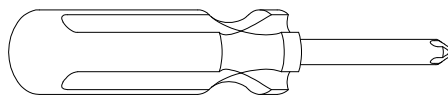

| | | | |
|---|---|--|--|
| <p>1</p>  <p>Hex - Head bolts Ø1/4" * 90 - 16pcs</p> | <p>2</p>  <p>Hex - Head bolts Ø1/4" * 80 - 18pcs</p> | <p>3</p>  <p>Horizontal - Hold bolts Ø1/4" - 34pcs</p> | <p>4</p>  <p>Wheel 4pcs</p> |
| <p>5</p>  <p>Wood dowel Ø8 * 30 - 24pcs</p> | <p>6</p>  <p>L - Bracket - 4pcs</p> | <p>7</p>  <p>Handle - 4pcs</p> | <p>8</p>  <p>Round crews Ø5/32" * 22 - 4pcs</p> |
| <p>9</p>  <p>Allen key K4 - 1pc</p> | <p>10</p>  <p>Wood crews M4 * 25 - 36pcs</p> | <p>11</p>  <p>Wood crews M3.5 * 15 - 16pcs</p> | |

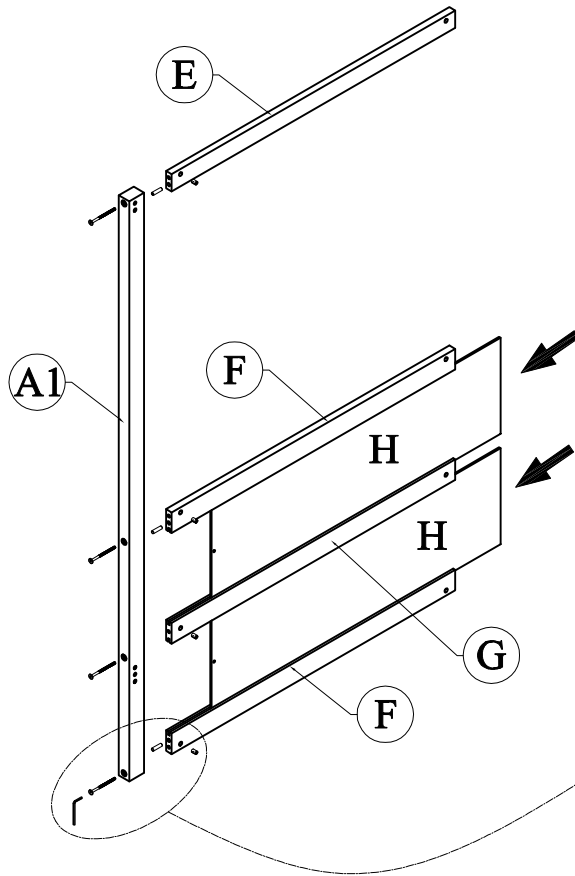

Assembly Tools Required (Not Included)

STEP 1



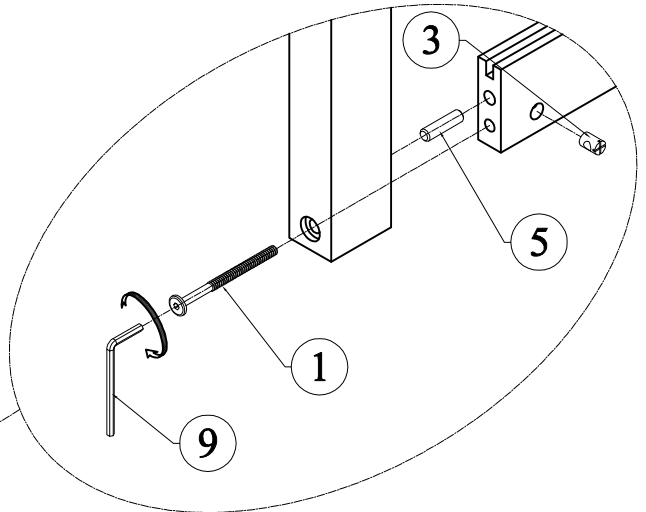

| | | |
|---|---|--|
| <p>1</p>  <p>Hex - Head bolts Ø1/4" * 90- 4pcs</p> | <p>3</p>  <p>Horizontal - Hold bolts Ø1/4" - 4pcs</p> | <p>5</p>  <p>Wood dowel Ø8 * 30 - 3pcs</p> |
|---|---|--|

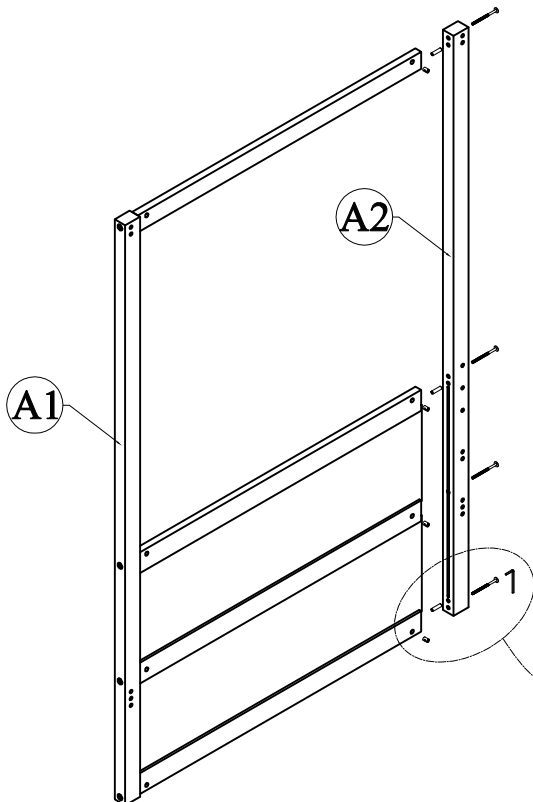

STEP 2



| | | |
|---|---|--|
| <p>1</p>  <p>Hex - Head bolts Ø1/4" * 90- 4pcs</p> | <p>3</p>  <p>Horizontal - Hold bolts Ø1/4" - 4pcs</p> | <p>5</p>  <p>Wood dowel Ø8 * 30 - 3pcs</p> |
|---|---|--|

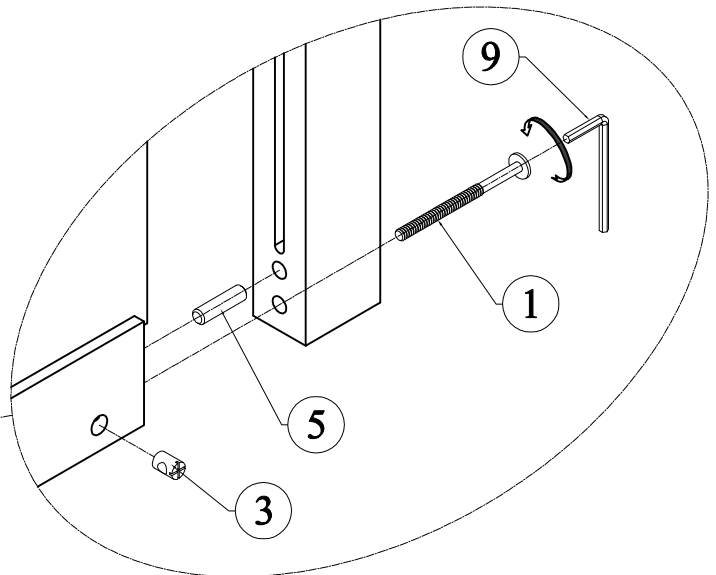

STEP 3

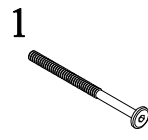
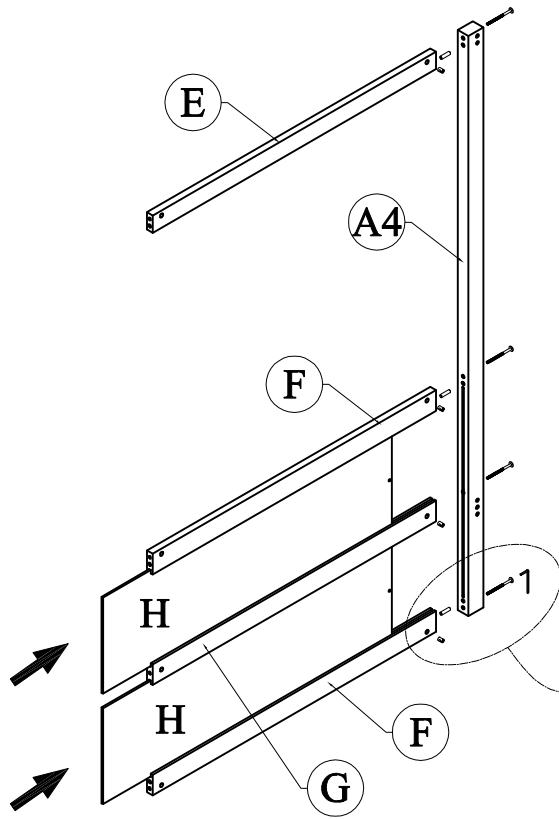

Hex - Head bolts
Ø1/4" * 90- 4pcs

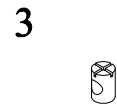

Horizontal - Hold bolts
Ø1/4" - 4pcs

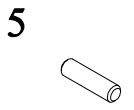

Wood dowel
Ø8 * 30 - 3pcs

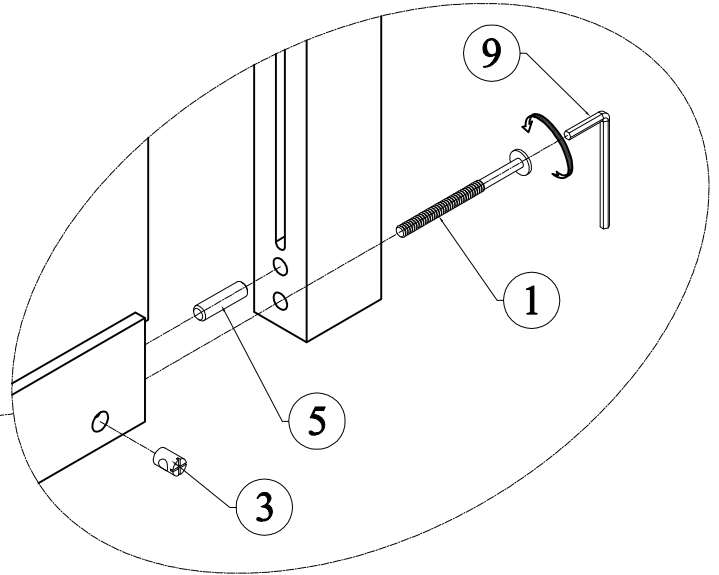

STEP 4

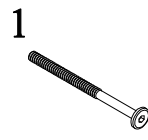
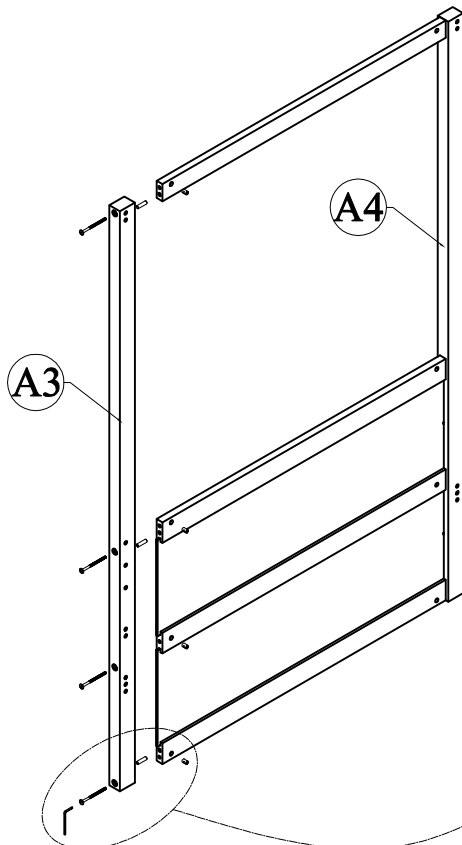

Hex - Head bolts
Ø1/4" * 90- 4pcs

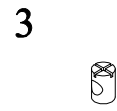

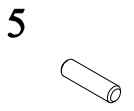

Horizontal - Hold bolts
Ø1/4" - 4pcs

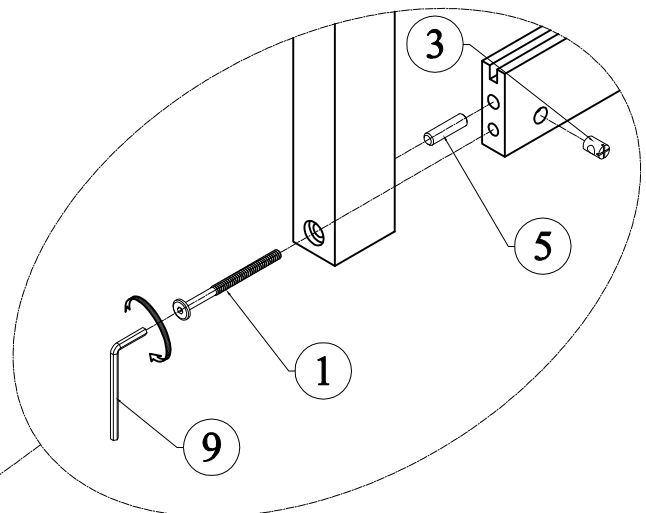

Wood dowel
Ø8 * 30 - 3pcs



STEP 5

- | | | |
|---|---|--|
| 2  Hex - Head bolts Ø1/4" * 80- 18pcs | 3  Horizontal - Hold bolts Ø1/4" - 18pcs | 5  Wood dowel Ø8 * 30 - 12pcs |
|---|---|--|

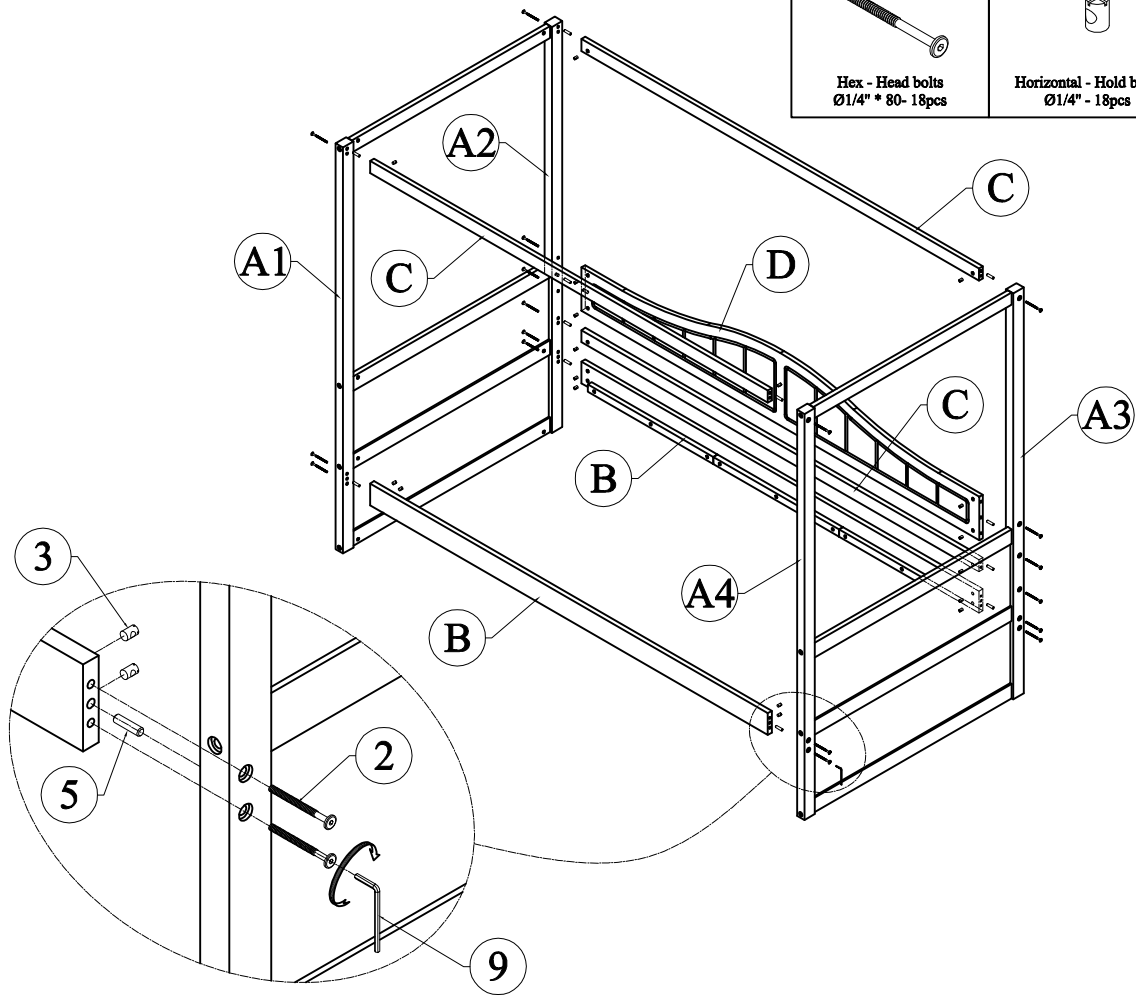

STEP 6

- | |
|---|
| 10  Wood crews M4 * 25 - 20pcs |
|---|

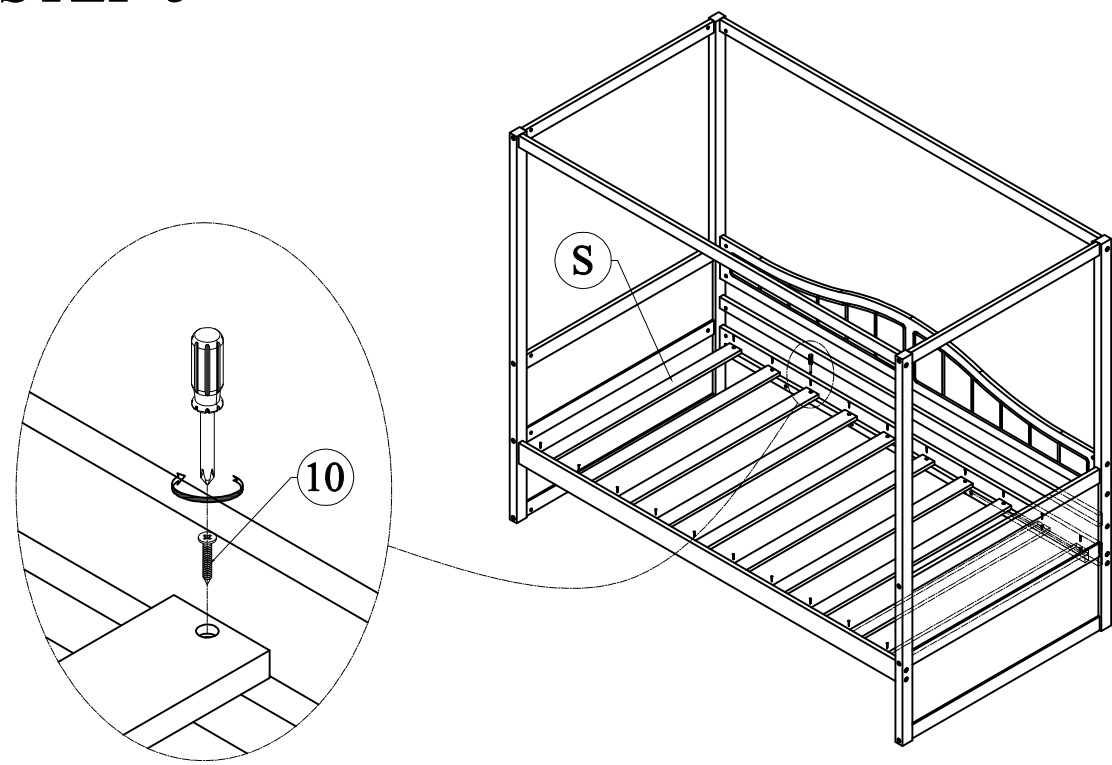

STEP 7

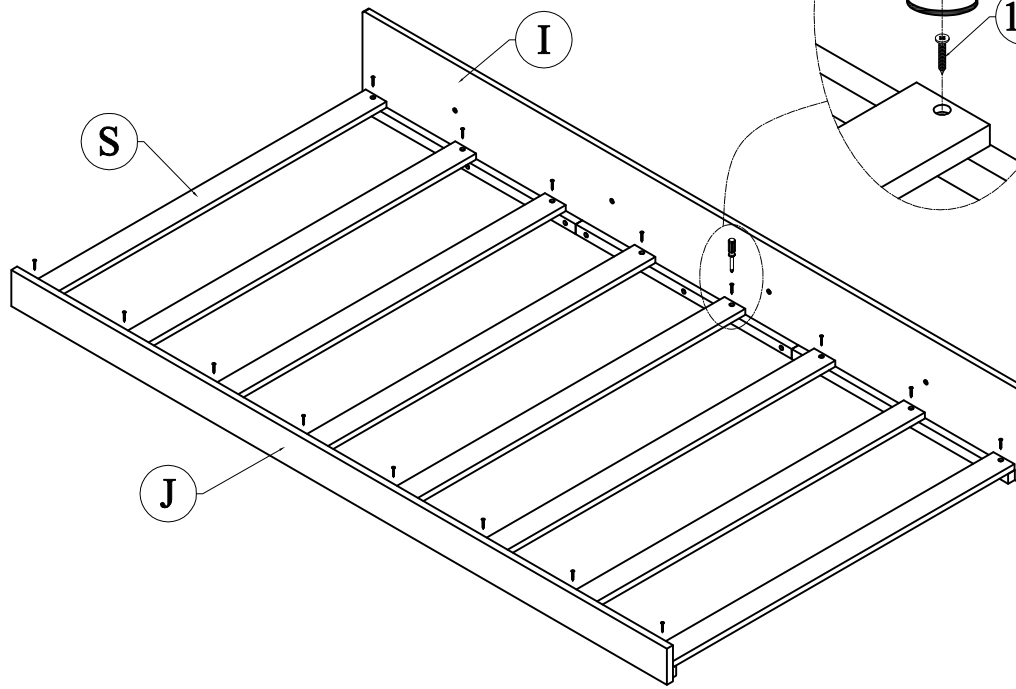

10



Wood screws
M4 * 25 - 16pcs

STEP 8

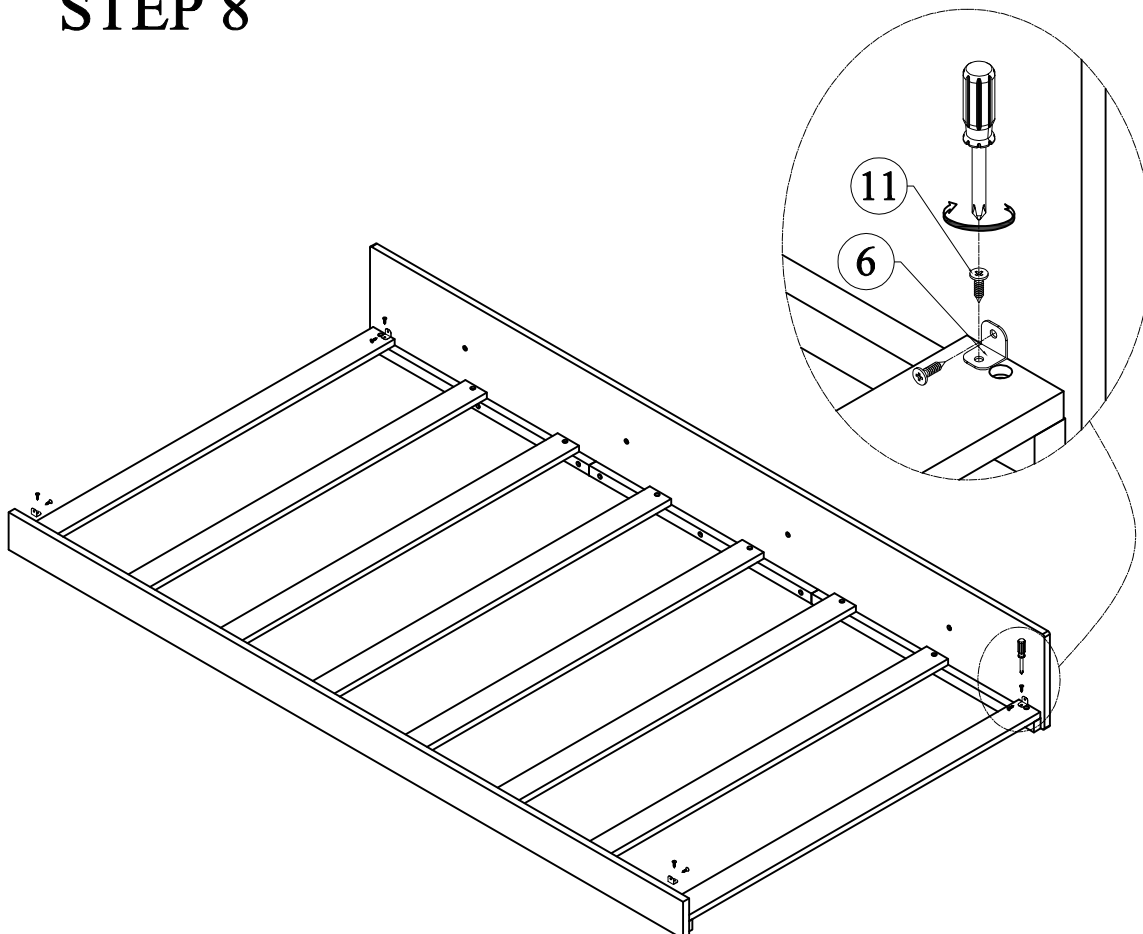

6



L - Bracket - 4pcs

11



Wood screws
M3.5 * 15 - 8pcs

STEP 9

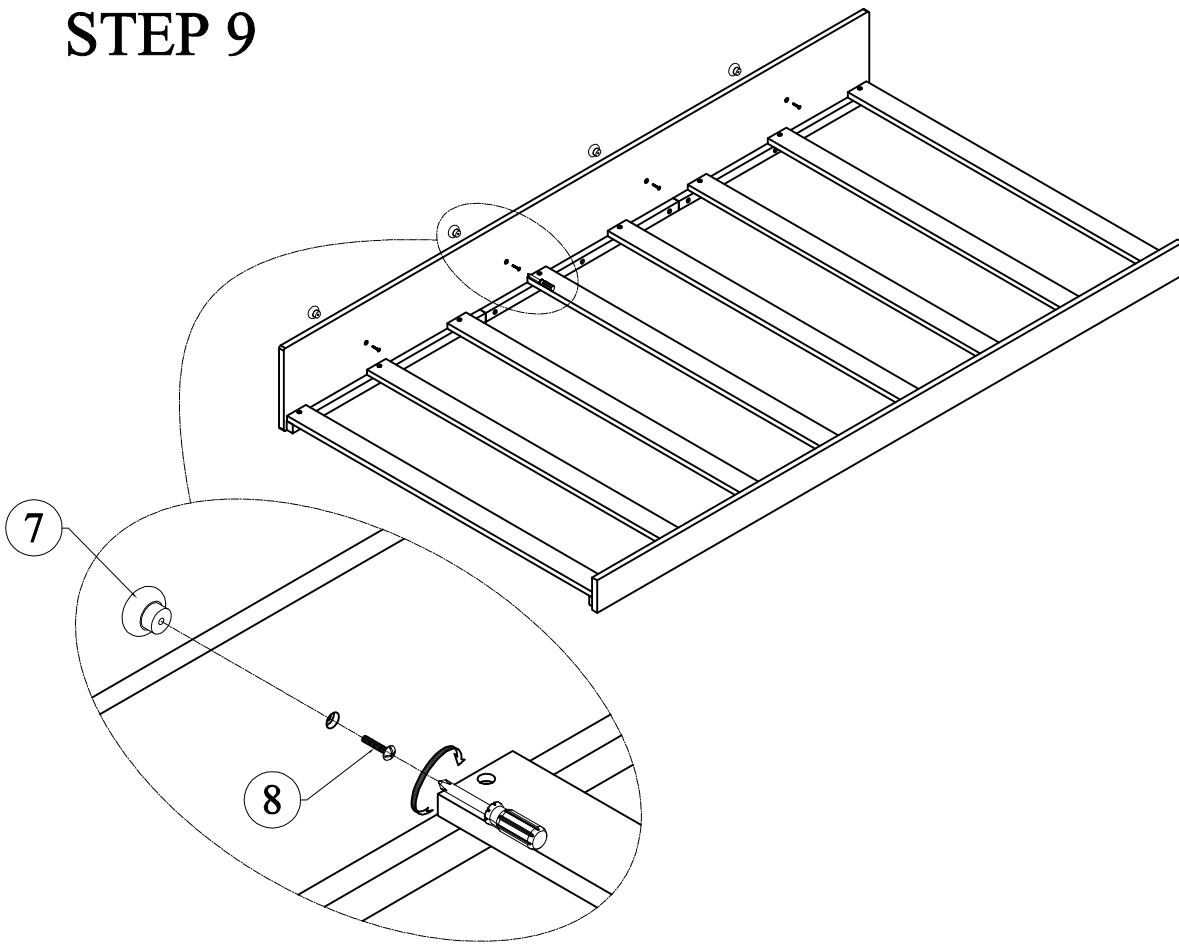

7



Handle - 4pcs

8



Round crews
Ø5/32" * 22 - 4pcs

STEP 10

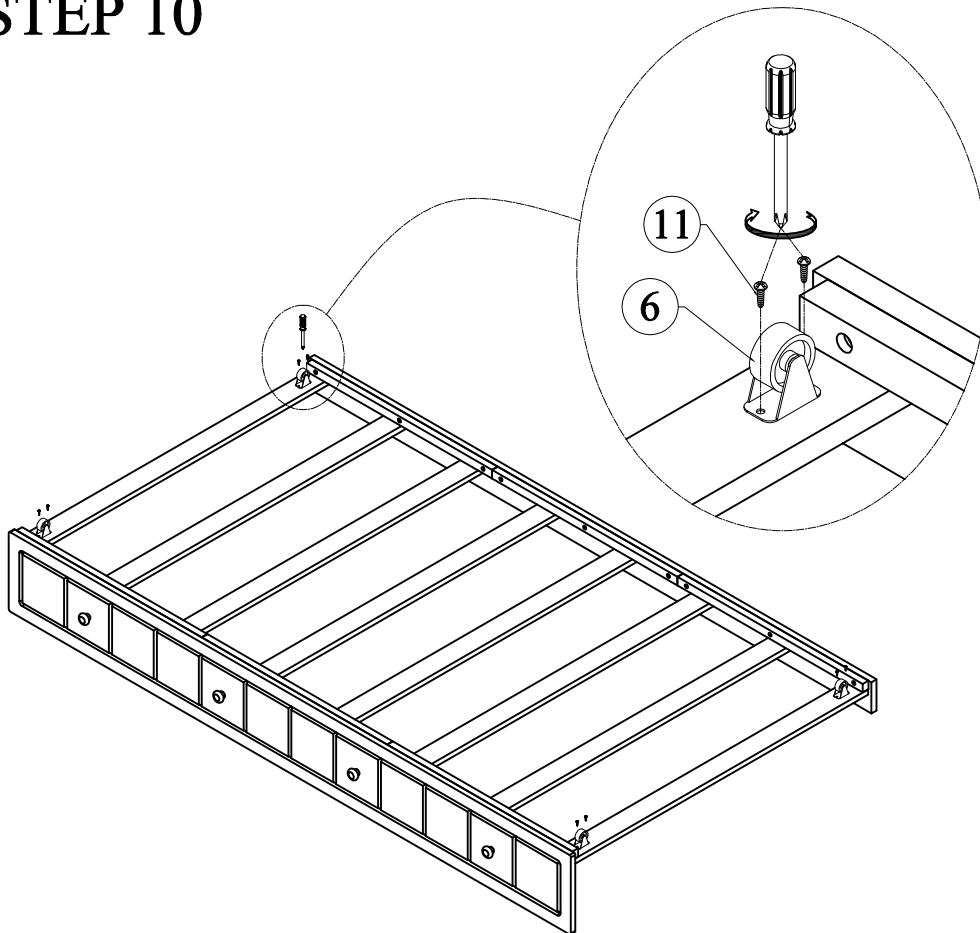

6



L - Bracket - 4pcs

11



Wood crews
M3.5 * 15 - 8pcs

STEP 11

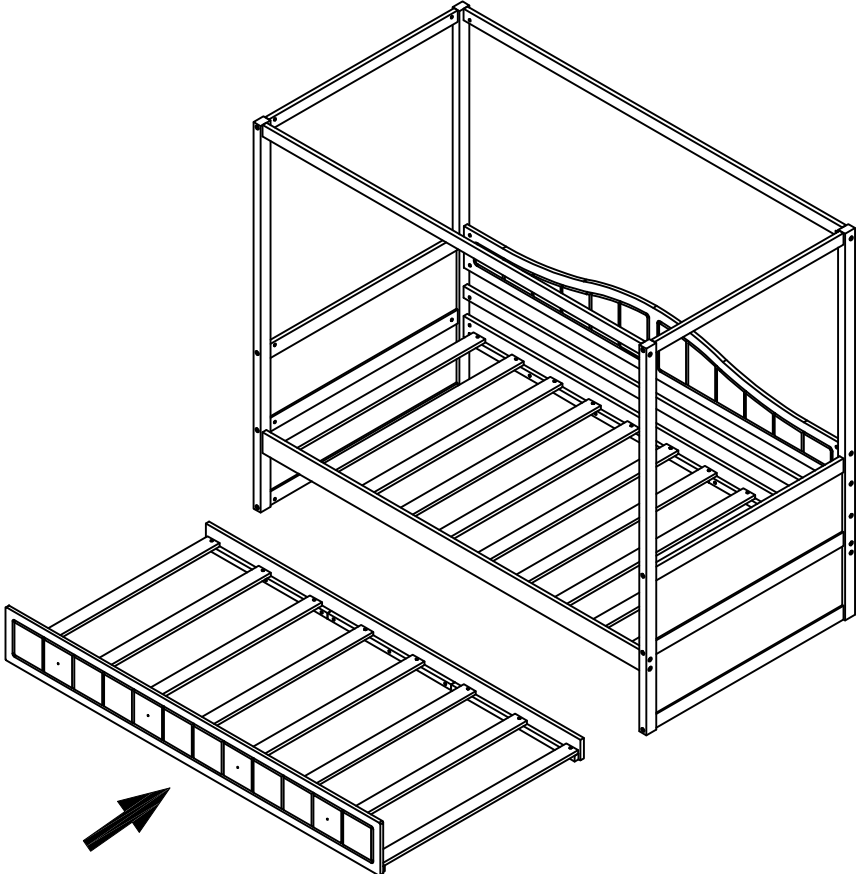

COMPLETED

