











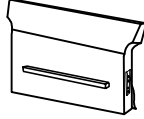

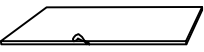

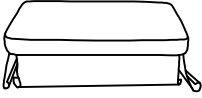
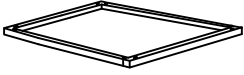
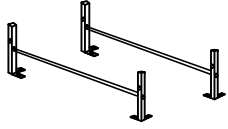
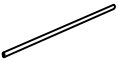

ASSEMBLY INSTRUCTION

A Seat cushion x1 	B Armrest-L X1 	C Armrest-R X1 	D Backrest x1 	E Front panel X1 
F Seat panel x1 	G Back Cushion x1 	H Ottoman cushion X1 	I Ottoman base X1 	J ottoman leg X2 
L ottoman base side iron x2 	N Leg x4 	O Velcro x4 	P Corner iron x2 	R Bolt M8*20 X16 
Q Washer M8*20 X 16 	S Allen wrench x1 8M 	T Bolt M6*35 X4 	U Allen wrench x1 6M 	V Corner cover x4 

You can follow the instructions as below which can make back cushion plumpy more faster .

1. Grab each end of the pillow with both hands.

It's like playing an accordion, pushing the pillow together and pulling it apart, be faster as you can .

If the pillow is not absorbing too much moisture, you can use both fists to hit both sides of the pillow at the same time to loosen the stuffing.

2. Punch the throw pillow.

3. Squeeze the throw pillow.

Pls wait for 48-72 hours before using .

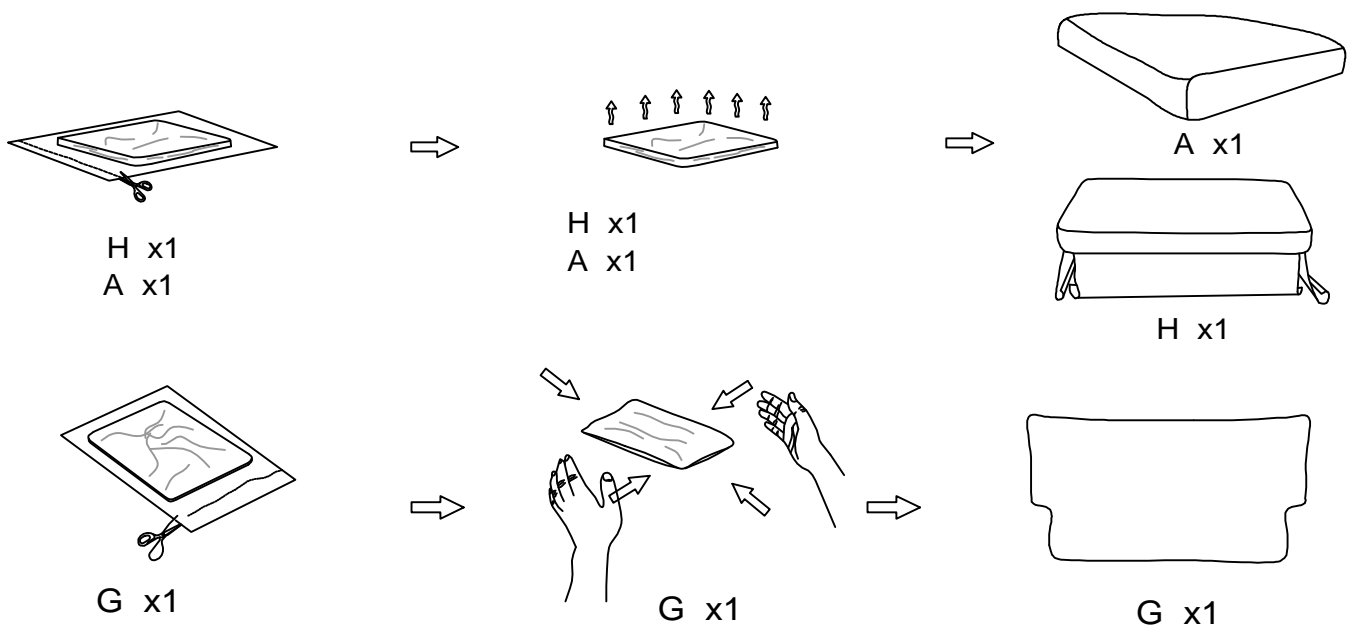

STEP1:

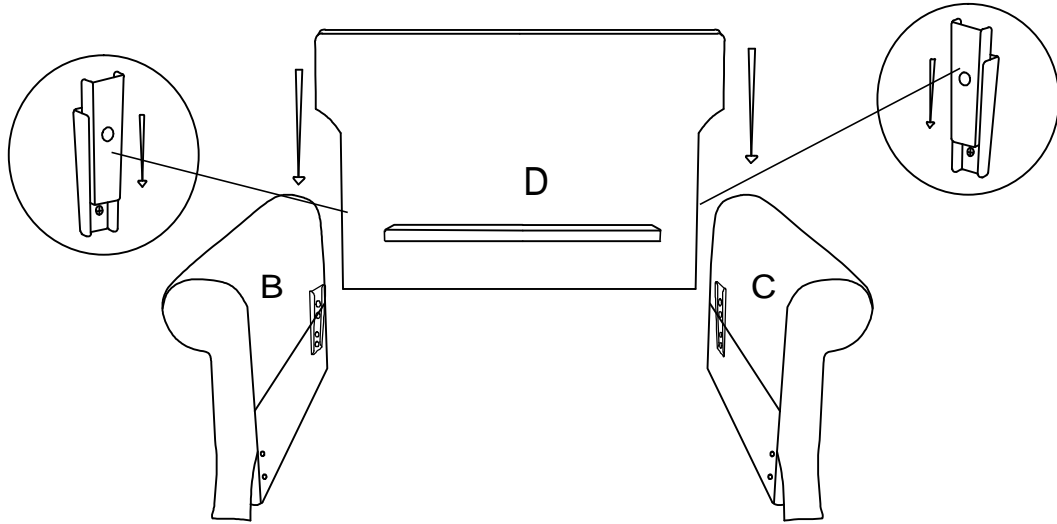

STEP2:

1.

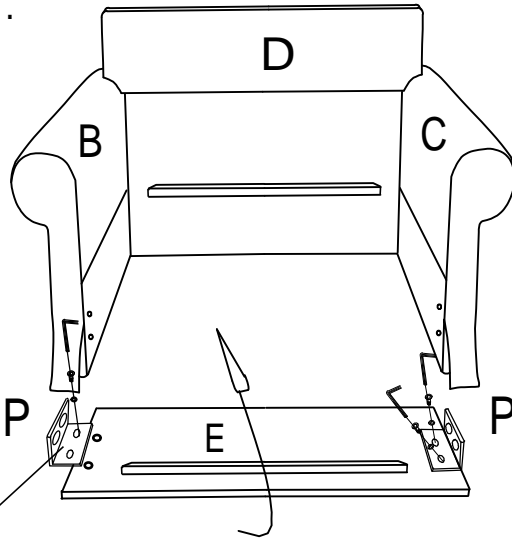

2.

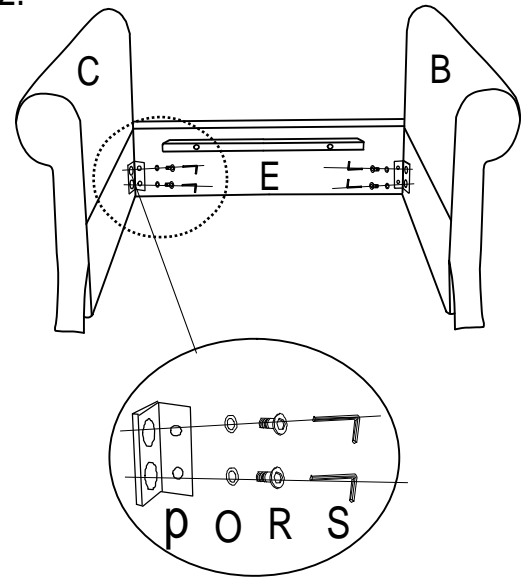

1. Use the round holes on the corner braces to connect the front panel. Do not fully tighten the screws at this stage.
2. Use the oval holes on the corner braces to connect the armrests. Once the holes on both sides are properly aligned, fully tighten all screws.

	P	x2pcs
	Q	x 8pcs
	R	x8pcs
	S	x 1pcs

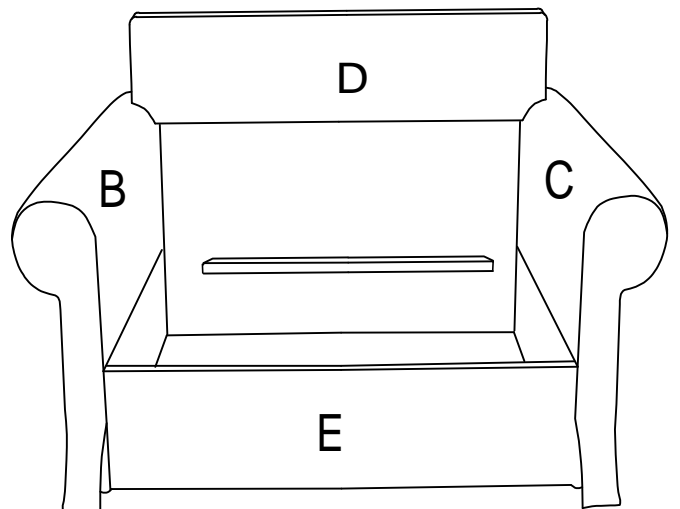

STEP3:

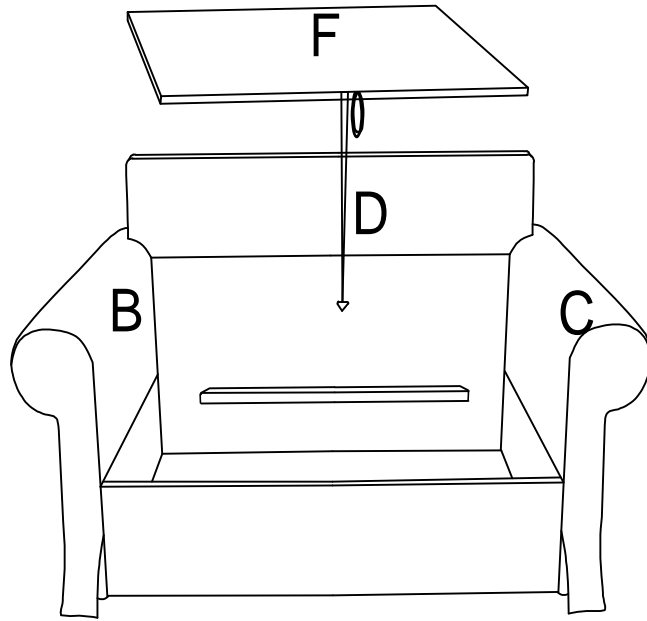

STEP4:

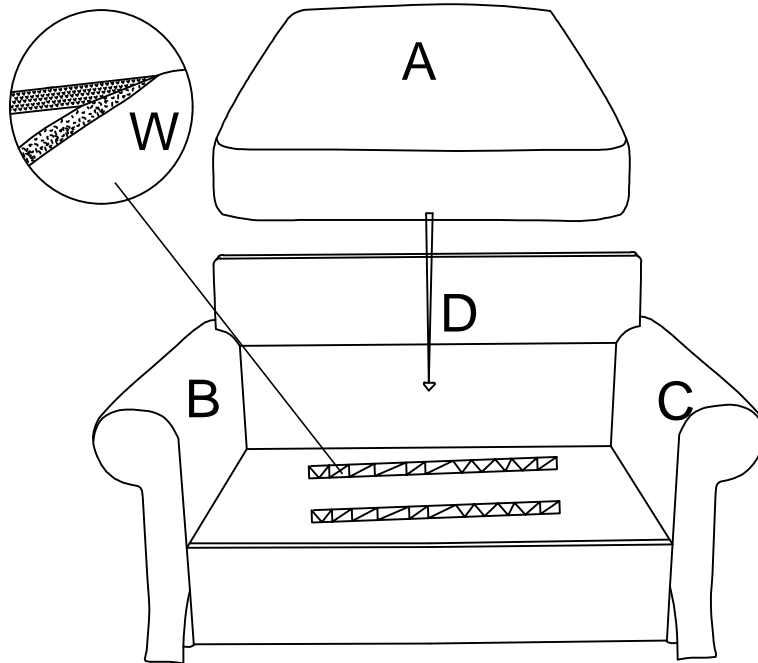

STEP5:

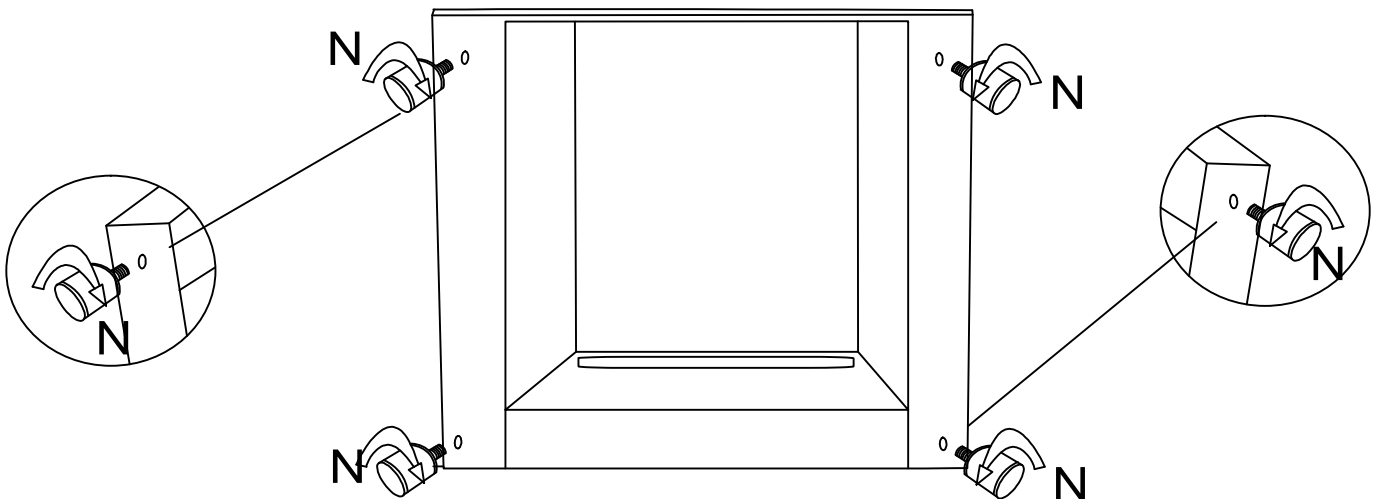

N x4pcs

3 OF 5

STEP6:

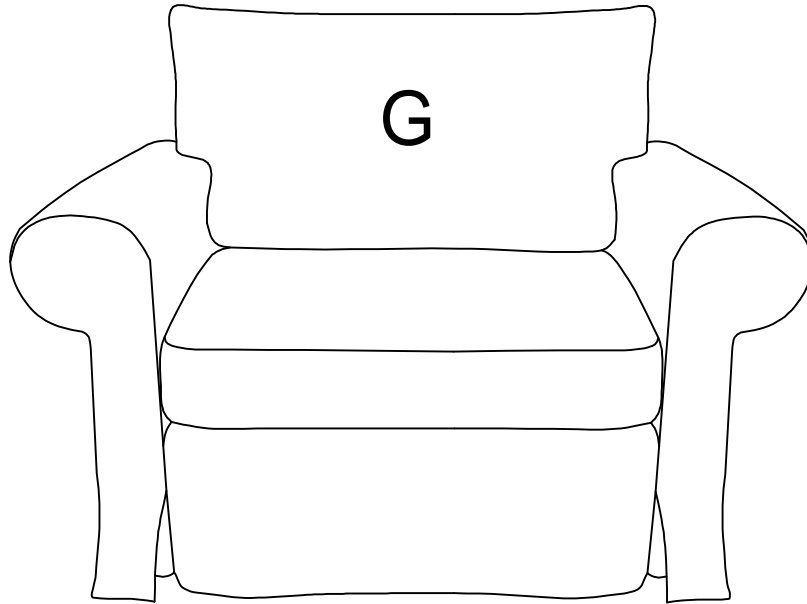

STEP7:

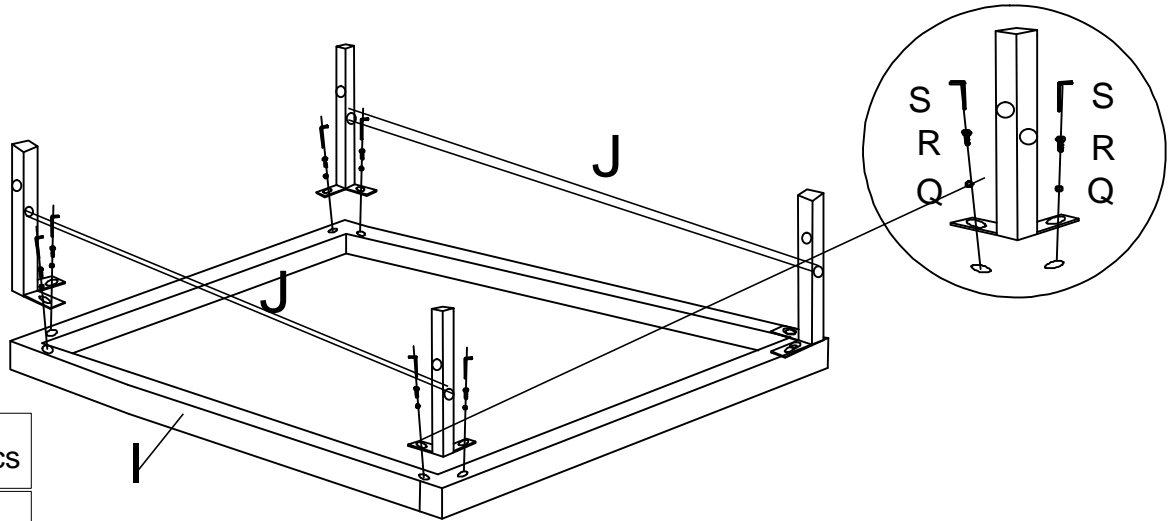

	Q	x 8pcs
	R	x8pcs
	S	x 1pcs

STEP8:

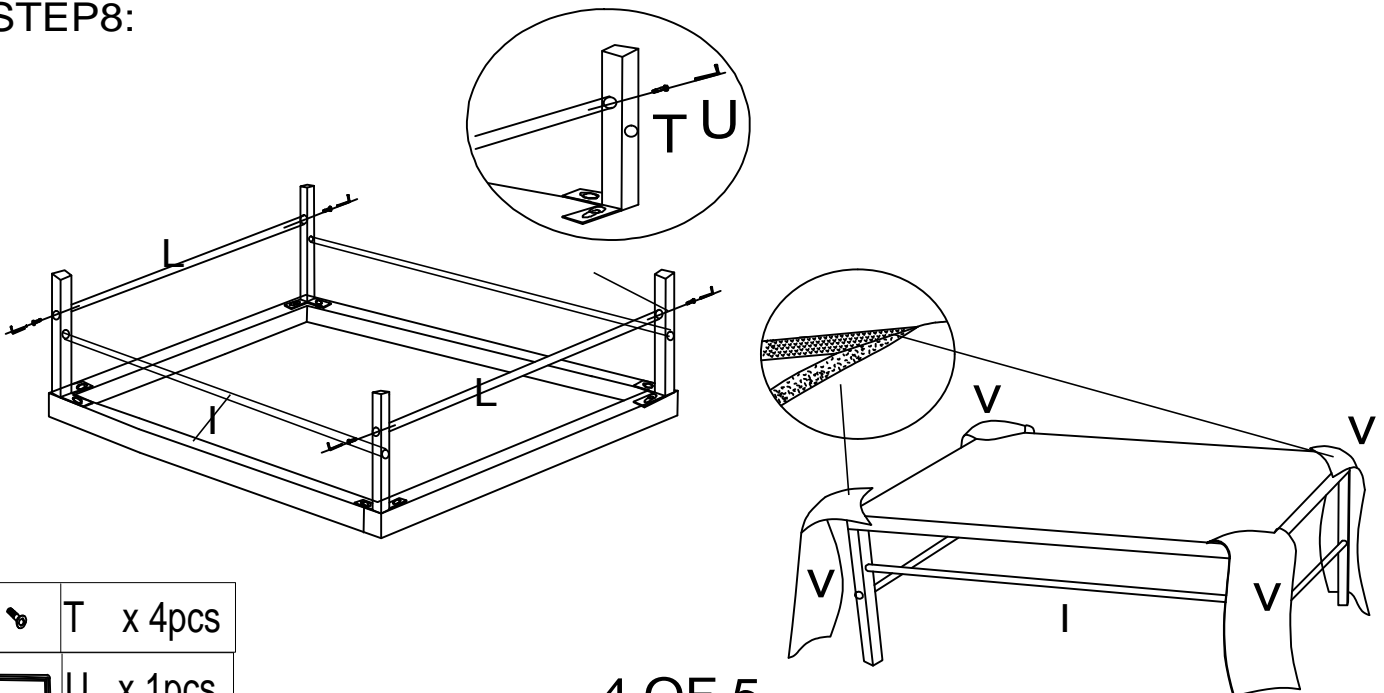

	T	x 4pcs
	U	x 1pcs

STEP9:

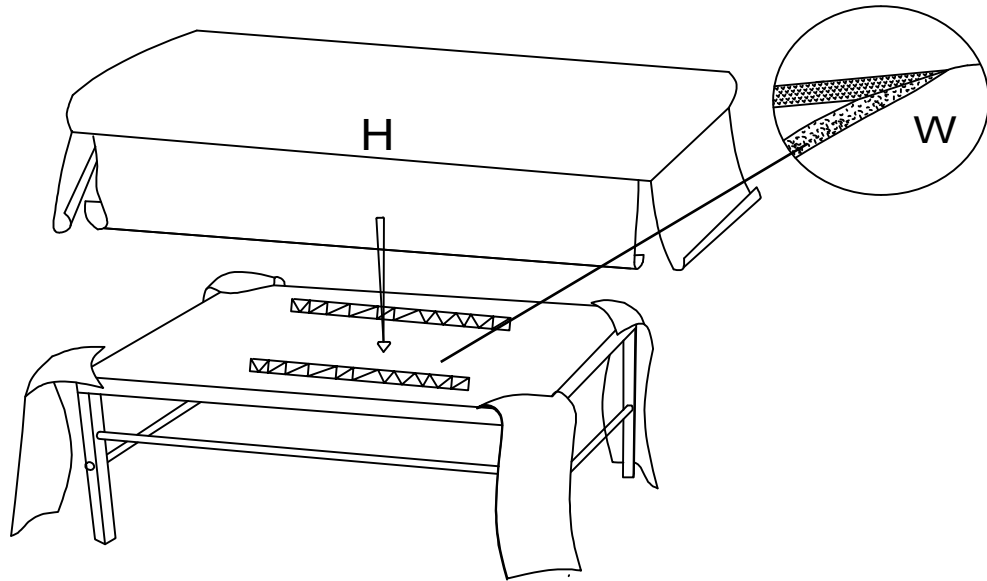

STEP10:

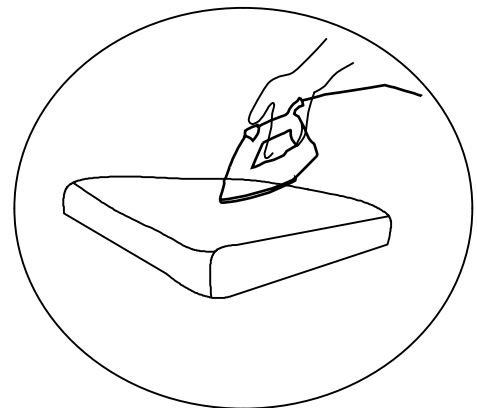
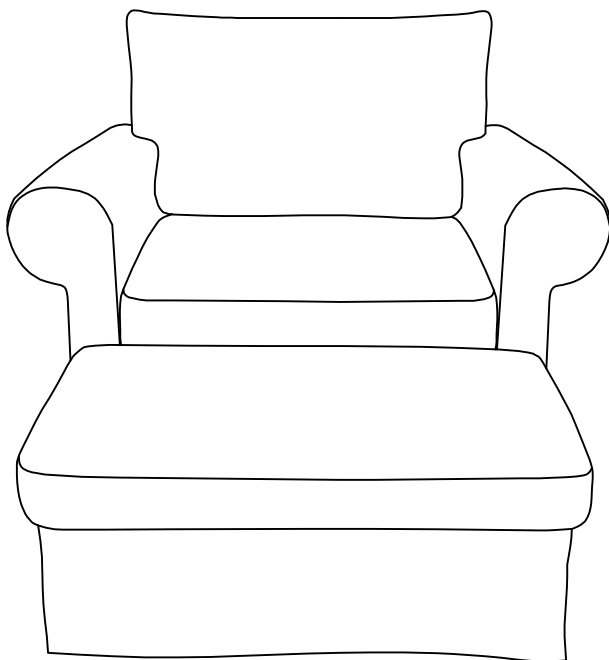
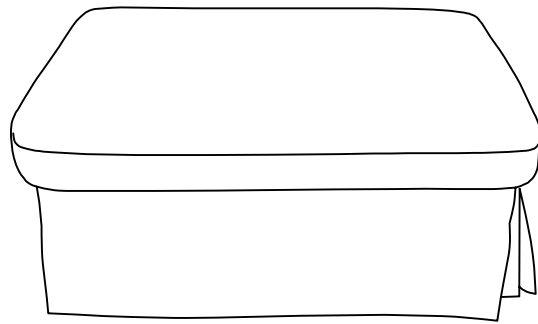

When the fabric is wrinkled, simply iron it to restore its smoothness.