

Assembly Instructions

Thank you for purchasing our products. Please review the assembly diagram before starting.

Note: Insert all screws/bolts loosely first. Once the item is fully assembled, positioned upright, and leveled, then tighten all screws/bolts completely.

PARTS LIST

NO.	DESCRIPTION	Q' ty
A	Top Frame	1
B	Shelf	1
C	Leg	4

HARDWARE LIST

NO.	DESCRIPTION	Q' ty
D	Flat washer	$\Phi 1/4" * 16\text{mm}$
E	Lock washer	$\Phi 1/4"$
F	Screw	$\Phi 1/4" * 1/2" L$
G	Screw	$\Phi 1/4" * 1-3/4" L$
H	Connecting Metal	$1-1/4" * 7/8" * 3/4" * 1/8"$
I	Allen Wrench	4mm
J	Screw	$\Phi 1/4" * 3/4" L$

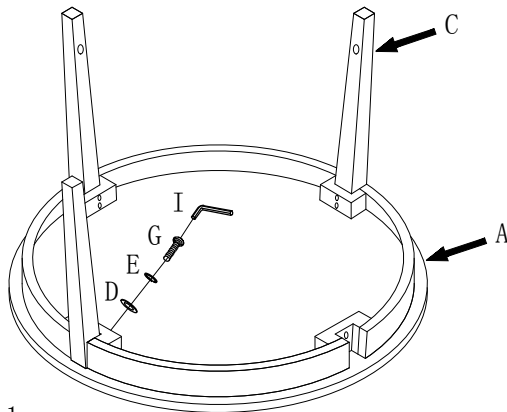
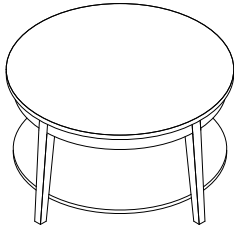

Step 1:

Place the face frame (A) face-down on a flat surface. Attach the 3 legs (C) to the face frame (A) using screws (G), spring washers E, and flat washers D, following this sequence.

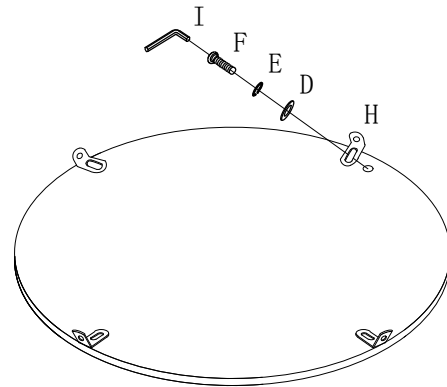

Step 2.

Place the Base Plate (B) face down on a flat surface. Secure the L-shaped iron piece (H) to the base plate (B) using the screws (F), spring washers (E), and flat washers (D) in the following order.

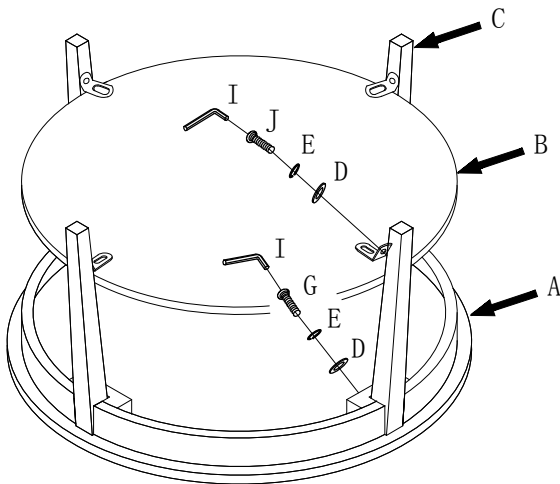

Step 3: Place the laminate (B) face down in the slots of the 3 legs (C). Secure the laminate (B) to the 3 legs (C) with screws (J), spring washers (E) and flat washers (D) through the L-shaped metal strip (H) and finally install the 4th leg. Install the 4th leg in the same manner as the other 3 legs, making sure to tighten all screws last.

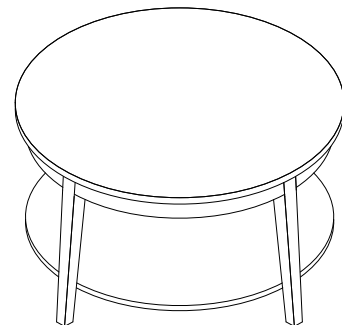

Use fittings according to the actual screw holes, extra fittings are spares