

To receive free replacement, Control No. and Proof-of-Purchase from an authorized dealer/retailer **MUST** be provided with request within 60 days from date of purchase.

Pour obtenir un remplacement gratuit, le numéro de contrôle et la preuve d'achat auprès d'un concessionnaire/magasin autorisé **DOIVENT** être fournis avec une demande soumise dans les 60 jours suivant la date d'achat.

Para recibir un reemplazo gratis, numero de Control y prueba de compra de un comerciante/vendedor autorizado, **DEBE** ser recibido dentro de 60 días desde la fecha de compra.

IMPORTANT! Please provide **CONTROL NO.** to ensure replacement parts will properly fit unit on hand.

IMPORTANT! Fournir N° de **CONTRÔLE** pour assurer que les pièces de recharge s'adaptent correctement à l'unité en question.

IMPORTANTE! Favor de proporcionar el **NUMERO DE CONTROL** para garantizar que las piezas de reemplazo ajuste corrctame su productor.

Missing parts request:

To obtain replacement part(s), fill in quantity in the "missing" box under the "Parts List" section. Complete contact and shipping information in address box accurately and clearly. Please allow 7-14 days for delivery.

Demande de pièces manquantes:

Pour obtenir une (des) pièce(s) de remplacement, remplissez la case « manquant » sous la section « Liste des pièces ». Fournissez vos coordonnées et informations d'expédition dans la case Adresse de manière claire et précise. La livraison aura lieu dans un délai de 7 à 14 jours.

Petición de partes perdidas:

Para obtener parte(s) de reemplazo, llené en número la cantidad en el cuadro de "missing" debajo de "Lista de partes" sección. Llené su información de contacto y envíe en el cuadro de dirección clara y correcta. Por favor permita 7-14 días para envío.

Name - Nom - Nombre

Address - Adresse - Dirección

City/State/Zip - Ville/Province/Code postal - Ciudad/Estado/Zona Postal

Phone - Téléphone - Teléfono

Email

Reason of replacement part(s)

Raison de(s) pièce(s) de remplacement - Razón del reemplazo la parte(s):

- Missing/Manquant/Ausente Not Fit/Ne rentre pas/No ajusta
 Damaged/Endommagé/Dañado Other/Autre/Otro:

Provide Details/Fournis détails/Proporcionar detalles:

Parts List - Liste des pièces - Lista de partes

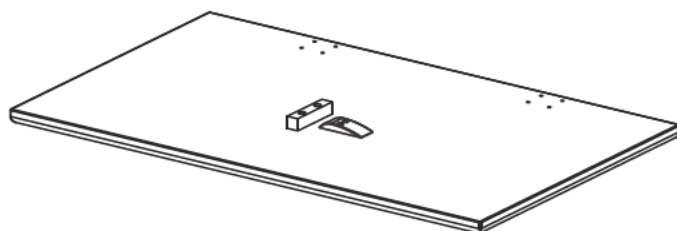

A	Drop-Leaf Rallonge Hoja plegable		
Quantity Quantité Cantidad	2	Replace Remplacer Reemplazar	

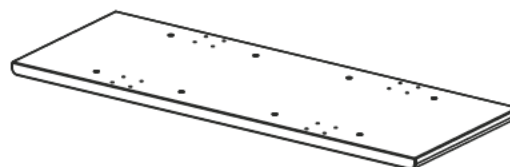

B	Table Top Dessus de table Tapa de mesa		
Quantity Quantité Cantidad	1	Replace Remplacer Reemplazar	

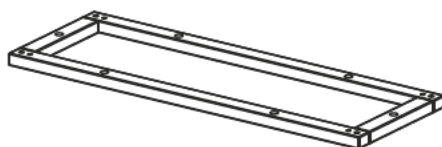

C	Side Frame Cadre latéraux Bastidor lateral		
Quantity Quantité Cantidad	2	Replace Remplacer Reemplazar	

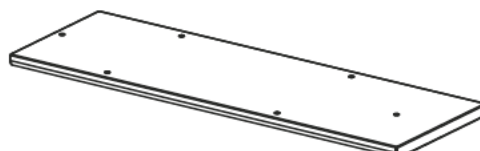

D	Side Panel Panneau latéraux Panel lateral		
Quantity Quantité Cantidad	2	Replace Remplacer Reemplazar	

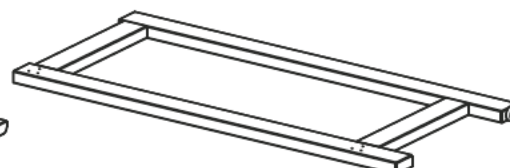

E	Leg Pied Pata		
Quantity Quantité Cantidad	2	Replace Remplacer Reemplazar	

IMPORTANT! Please provide
CONTROL NO. to ensure replacement parts
will properly fit unit on hand.

IMPORTANT! Fournir N° de CONTRÔLE pour
assurer que les pièces de recharge s'adaptent
correctement à l'unité en question.

IMPORTANTE! Favor de proporcionar el
NUMERO DE CONTROL para garantizar que las
piezas de reemplazo ajuste correctamente su productor.

Name - Nom - Nombre

Address - Adresse - Dirección

City/State/Zip - Ville/Province/Code postal - Ciudad/Estado/Zona Postal

Phone - Téléphone - Teléfono

Email

Reason of replacement part(s)
Raison de(s) pièce(s) de remplacement
Razón del reemplazo la parte(s):

- Missing/Manquant/Ausente
 Damaged/Endommagé/Dañado
 Not Fit/Ne rentre pas/No ajusta
 Other/Autre/Otro:

Provide Details/Fournis détails/Proporcionar detalles:

Parts List - Liste des pièces - Lista de partes

- * Screw Driver is required and not included in the package.
* Un tournevis est nécessaire mais n'est pas inclus avec cet ensemble.
* Se requiere desarmador de cruz y no viene incluido.

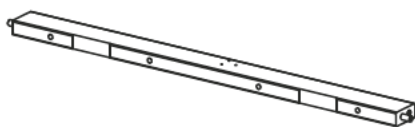

F	Cross Support (Upper) Support transversal (supérieure) Soporte atravesado (superior)	Quantity Quantité Cantidad	2	Replace Remplacer Reemplazar
----------	--	----------------------------------	---	------------------------------------

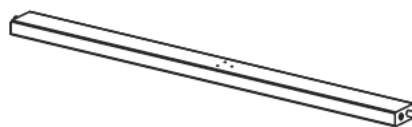

G	Cross Support (Lower) Support transversal (inférieure) Soporte atravesado (de abajo)	Quantity Quantité Cantidad	2	Replace Remplacer Reemplazar
----------	--	----------------------------------	---	------------------------------------

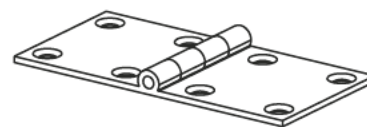

H	Hinge (for leaf) Charnière (pour rallonge) Bisagra (para hoja plegable)	Quantity Quantité Cantidad	4	Replace Remplacer Reemplazar
----------	---	----------------------------------	---	------------------------------------



I	Hex Bolt (Long) Boulon hexagonable (long) Tornillo hexagonal (largo)	Quantity Quantité Cantidad	16	Replace Remplacer Reemplazar
----------	--	----------------------------------	----	------------------------------------



J	Hex Bolt (Short) Boulon hexagonable (court) Tornillo hexagonal (corto)	Quantity Quantité Cantidad	12	Replace Remplacer Reemplazar
----------	--	----------------------------------	----	------------------------------------

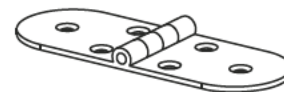

K	Hinge (for leg) Charnière (pour pied) Bisagra (para pata)	Quantity Quantité Cantidad	4	Replace Remplacer Reemplazar
----------	---	----------------------------------	---	------------------------------------



For Hinge H (leaf)
Pour Charnière H (rallonge)
Para Bisagra H (hoja plegable)

L	Screw - Phillips* (Large) Vis - Phillips* (grand) Tornillo - Phillips* (grande)	Quantity Quantité Cantidad	32	Replace Remplacer Reemplazar
----------	---	----------------------------------	----	------------------------------------



For Hinge K (leg)
Pour Charnière K (pied)
Para Bisagra K (pata)

M	Screw - Phillips* (small) Vis - Phillips* (petit) Tornillo - Phillips* (pequeño)	Quantity Quantité Cantidad	24	Replace Remplacer Reemplazar
----------	--	----------------------------------	----	------------------------------------



	Hex Wrench Clé hexagonable Llave hexagonal	Quantity Quantité Cantidad	1	Replace Remplacer Reemplazar
--	--	----------------------------------	---	------------------------------------

Care instructions:

To clean, wipe with wet cloth and dry thoroughly. Use mild soap if necessary. Avoid use of commercial waxes or polishes or abrasive cleaning materials.

Instructions d'entretien:

Pour nettoyer, essuyez avec un linge humide et séchez à fond. Utilisez un savon doux au besoin. Évitez d'utiliser des cires ou produits à polir de type commercial ou des matériaux de nettoyage abrasifs.

Instrucciones para el cuidado:

Para limpiar, frótelo con algo húmedo y séquelo bien. Use un jabón suave si es necesario. Evite el uso de ceras o pulidores comerciales o materiales abrasivos.

1

↓
Assemble Unit UPSIDE DOWN
Assembler en tenant l'unité À L'ENVERS
Armé la unidad al revés

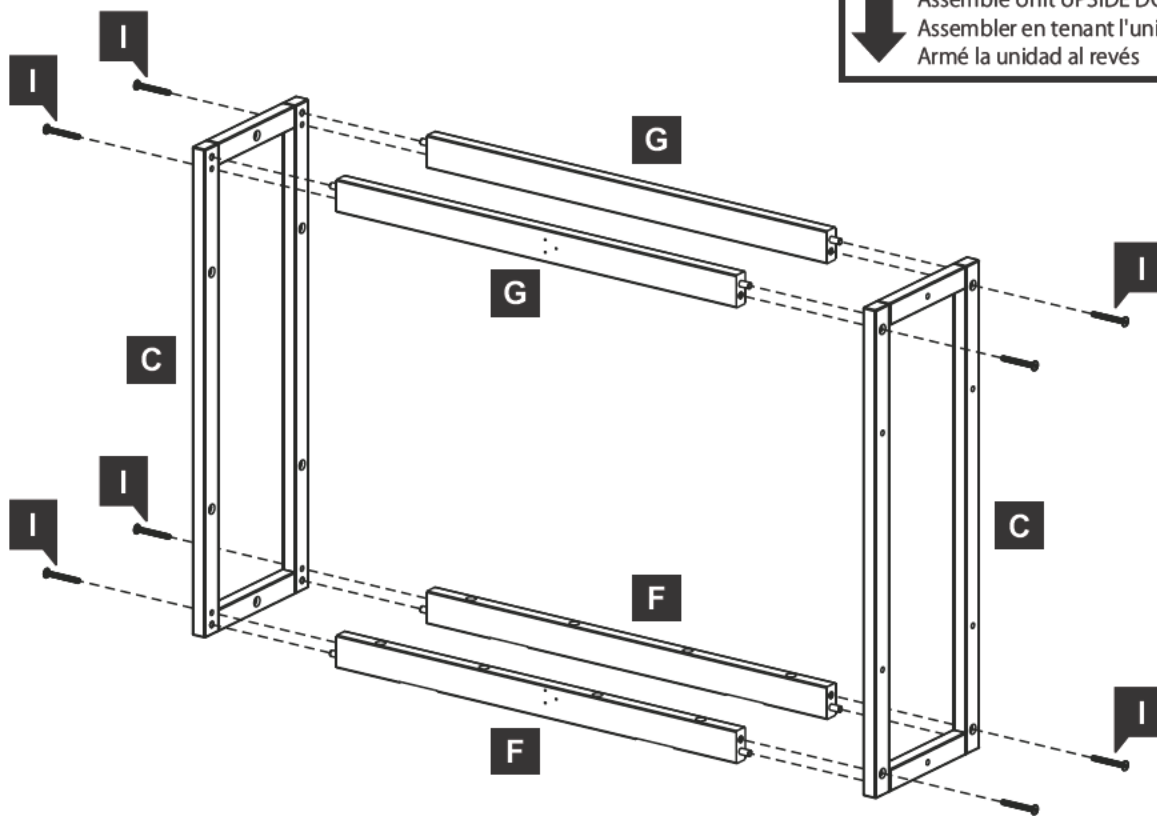

2

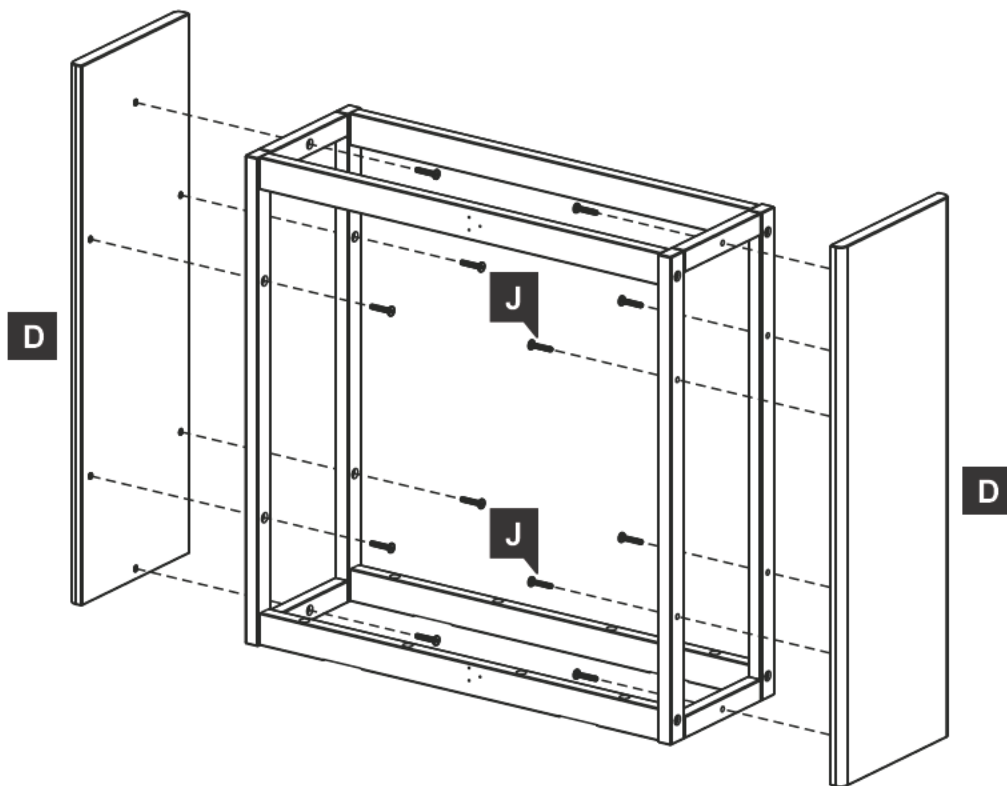

ASSEMBLY
ASSEMBLAGE
ENSAMBLAJE



TWO PERSONS
DEUX PERSONNES
DOS PERSONAS

3

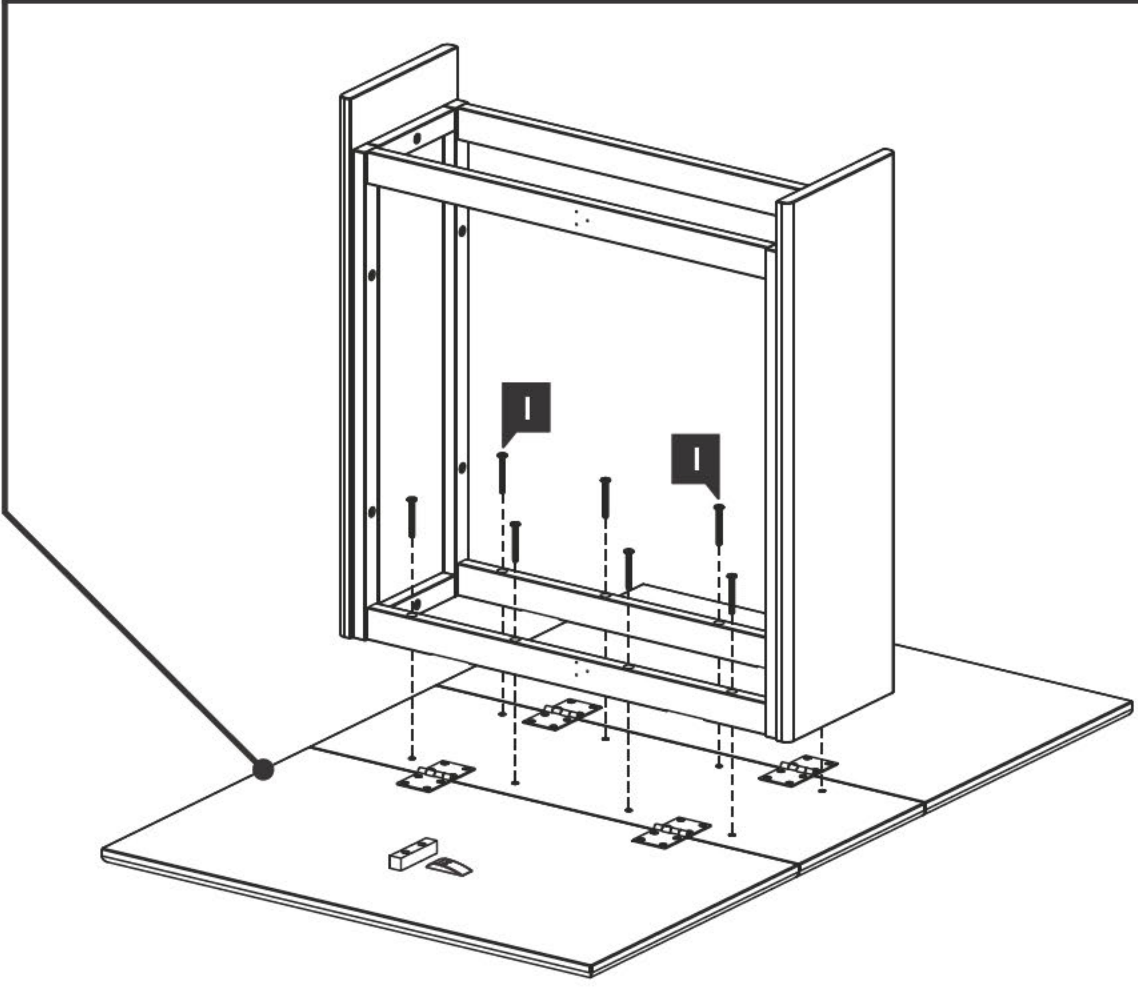
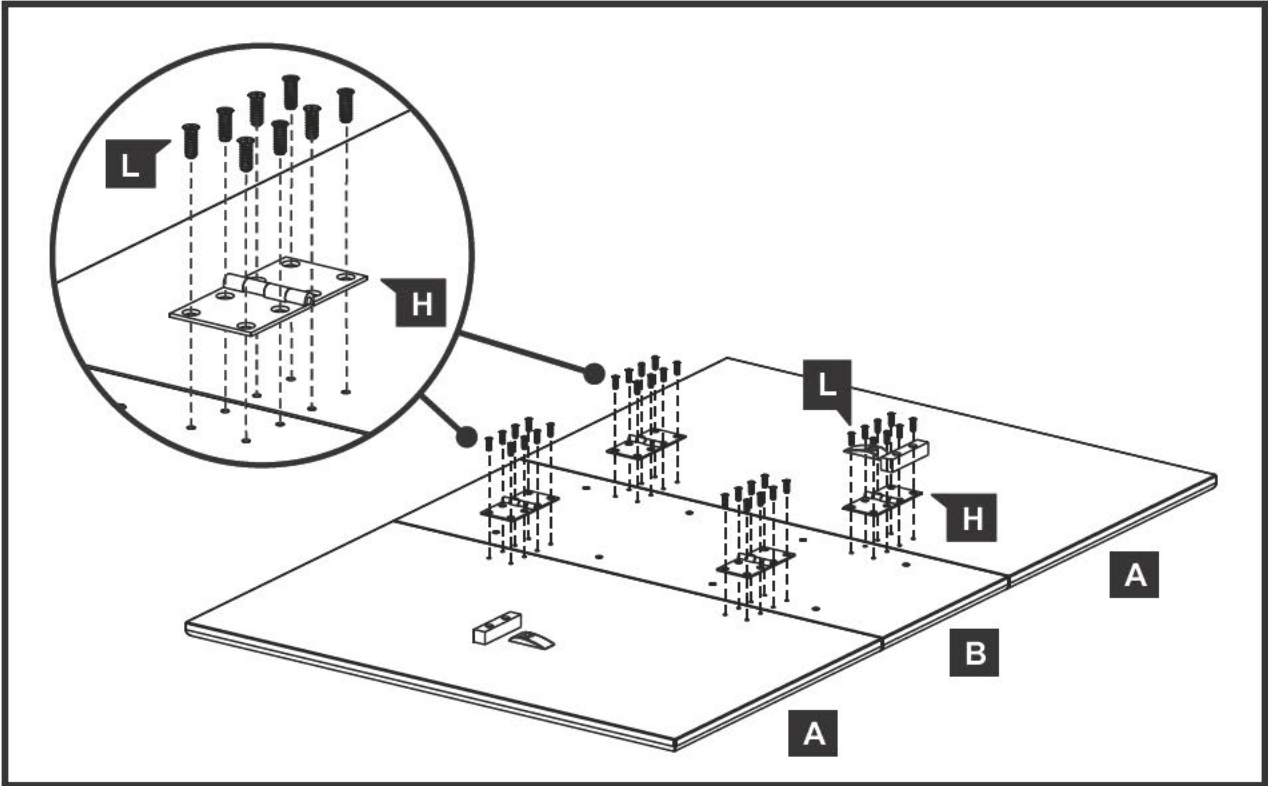

4

Leg - Pied - Pata
x 2

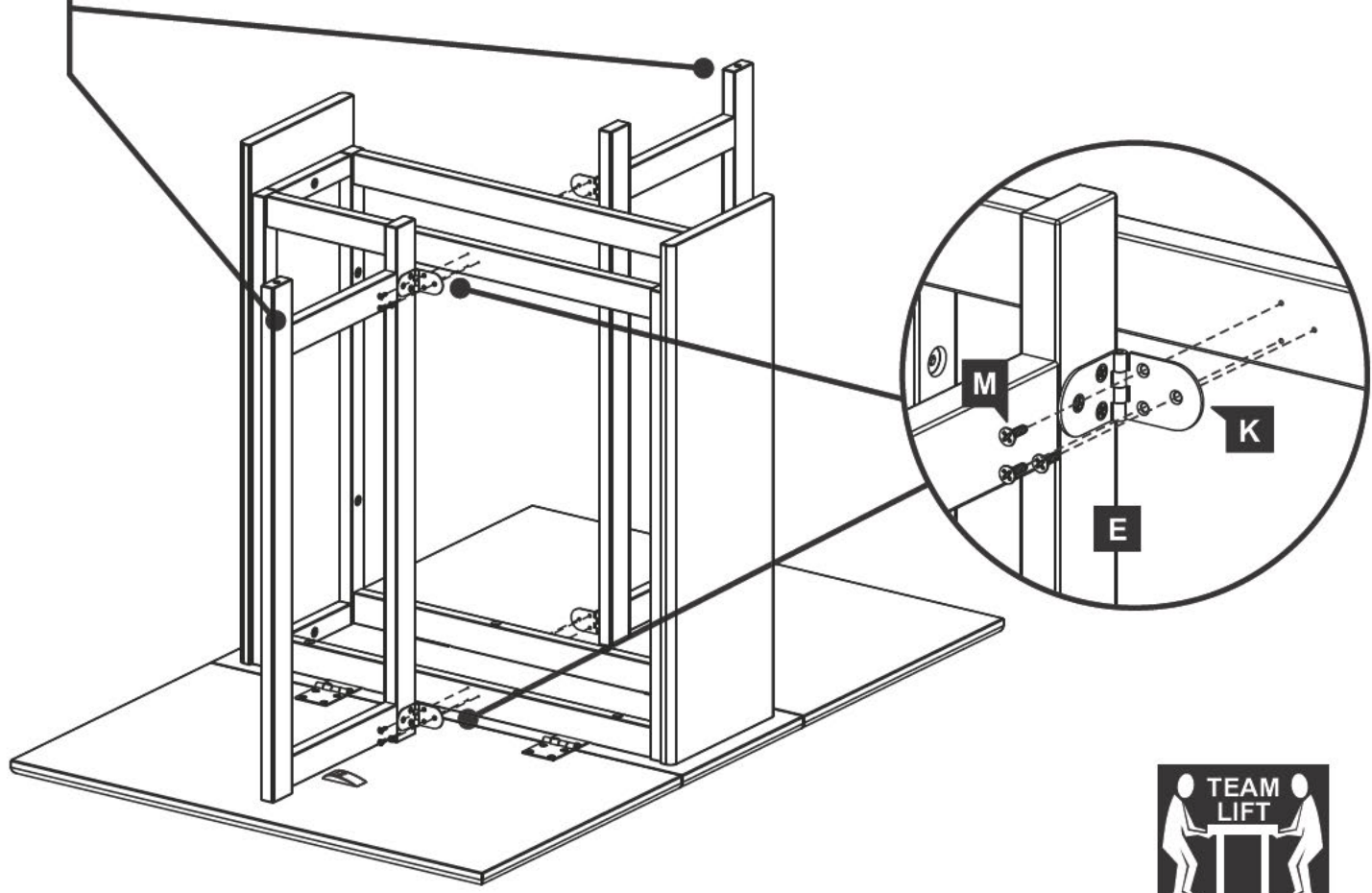
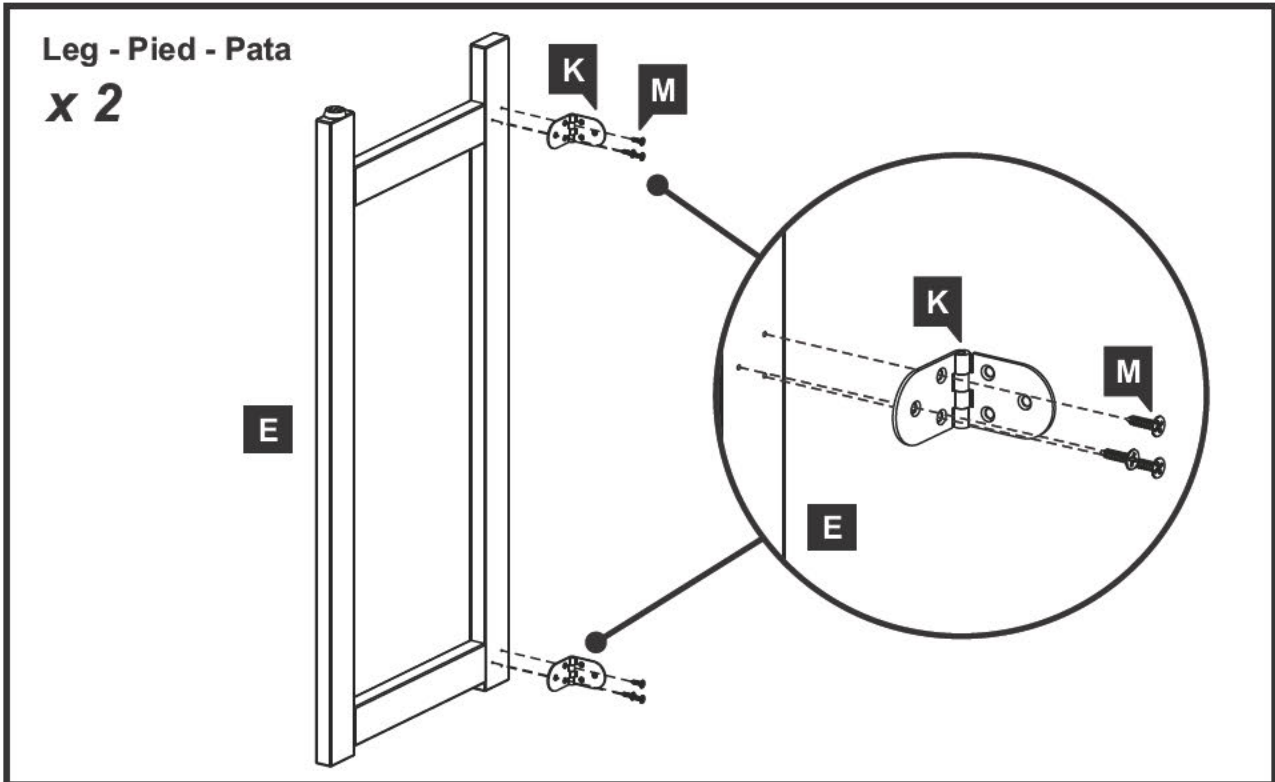

To fold drop-leaf
Pour replier rallonge
Plegar la tapa

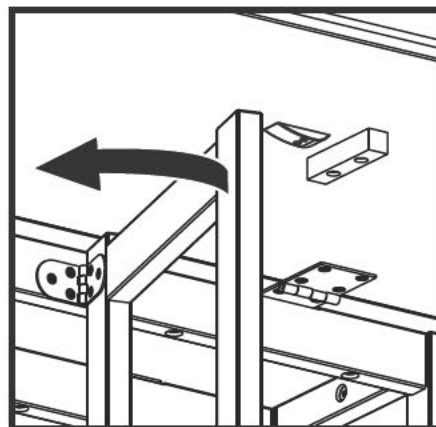
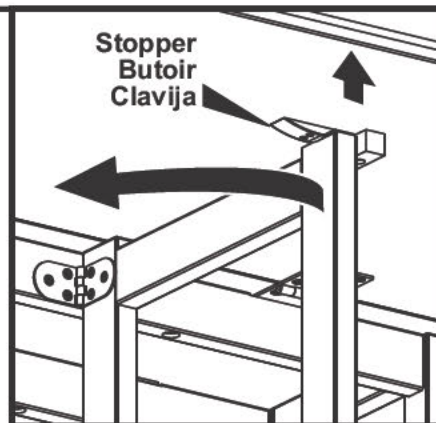
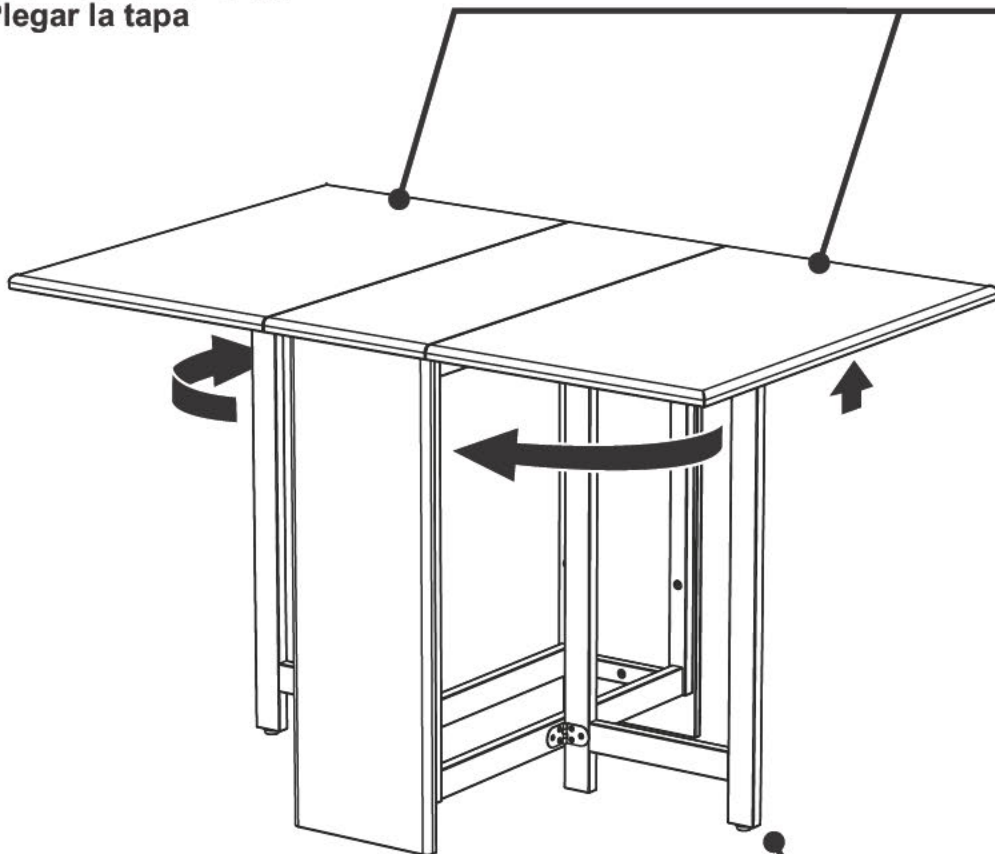

Turn to unlock
Tourner pour déverrouiller
Girar para desbloquear

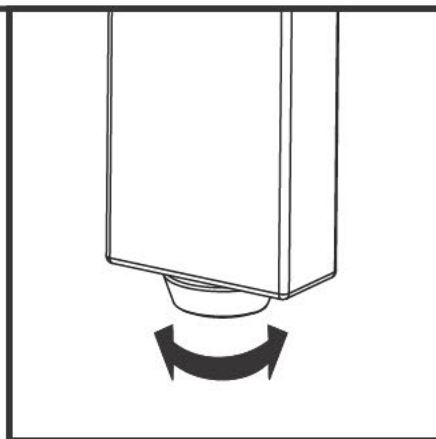
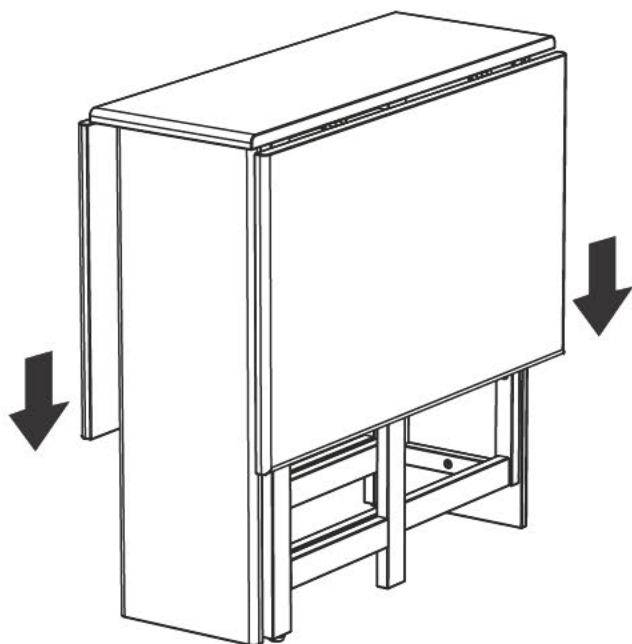

Foot Adjustor
Vis de réglage pour les pieds
Ajustador para las patas