

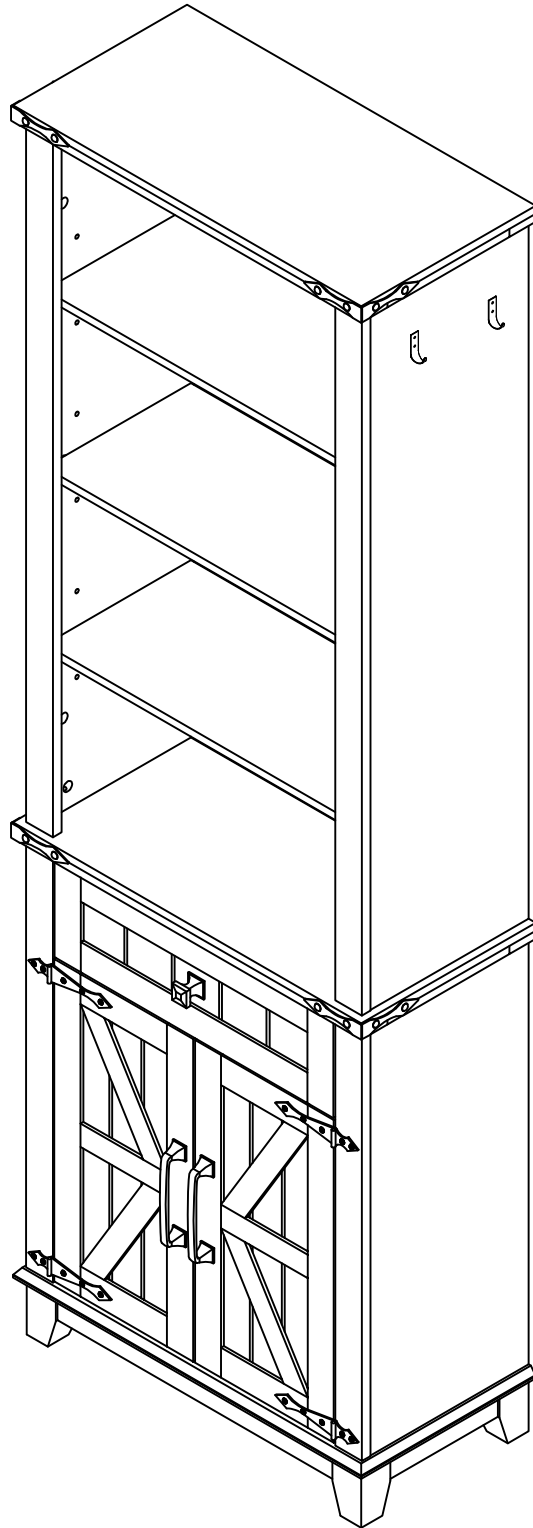

# Assembly Instructions

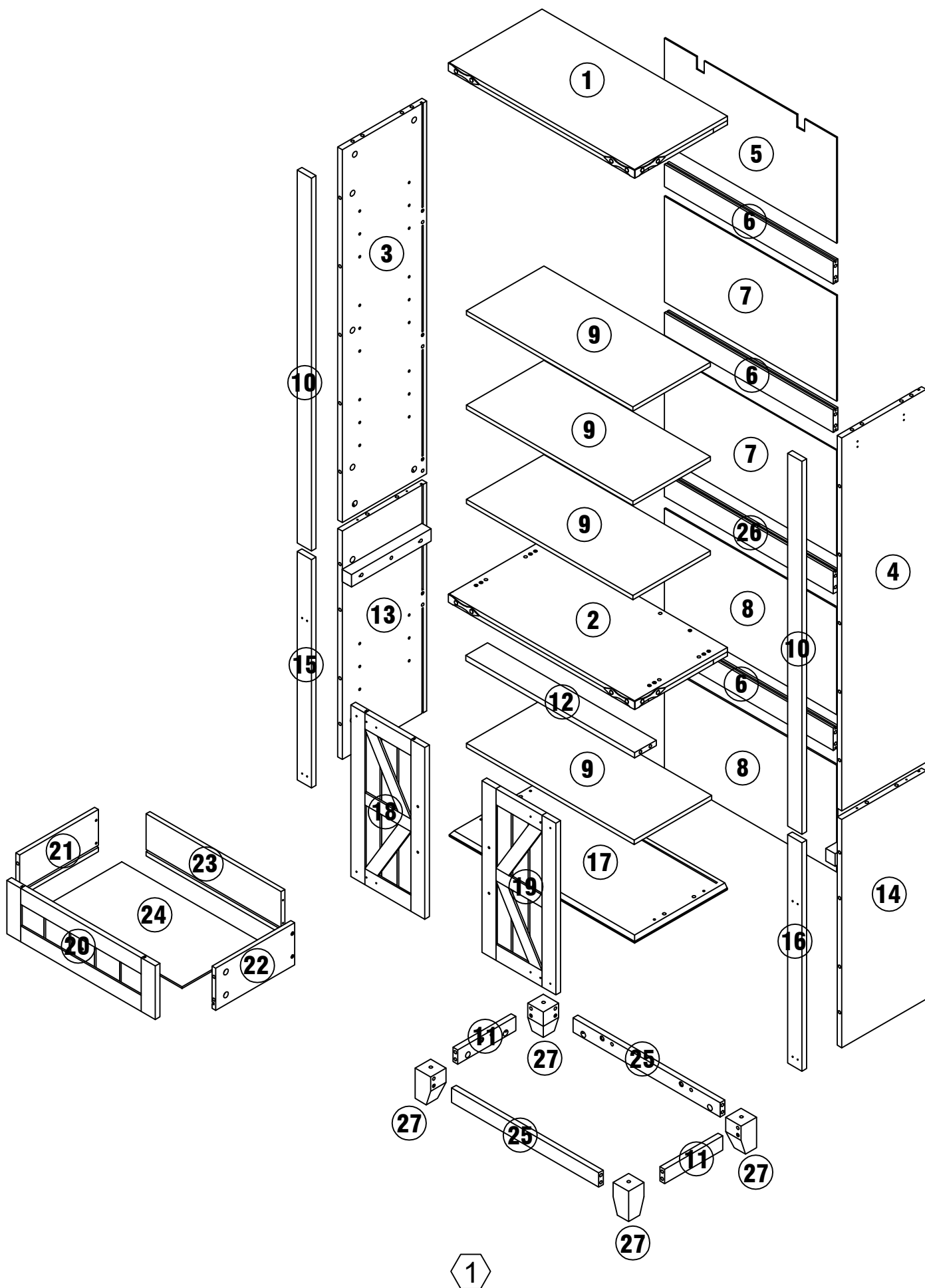



# PART LIST

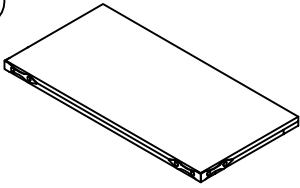
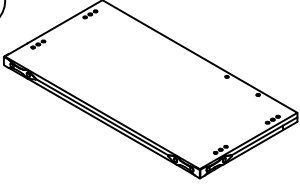
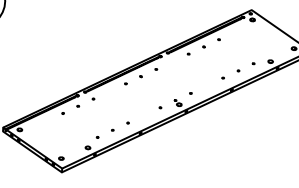
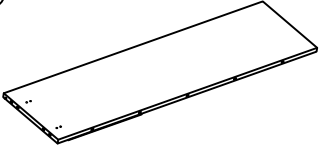
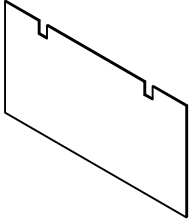
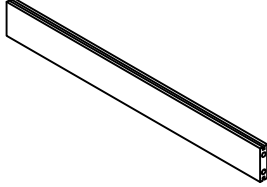
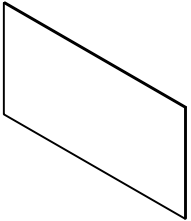
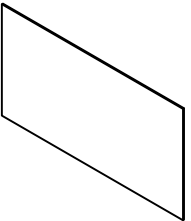
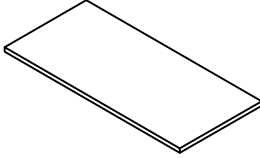
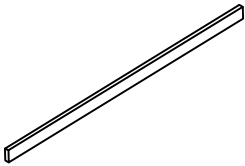
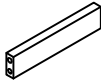
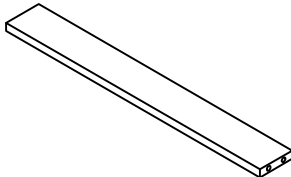
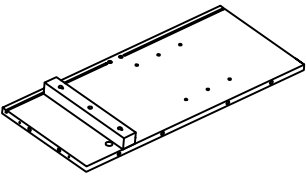
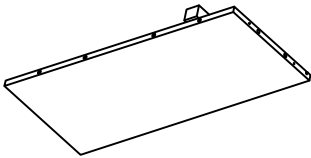
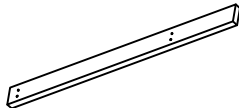
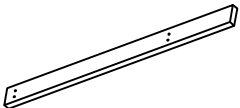
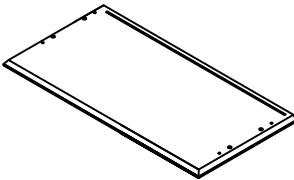
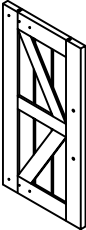

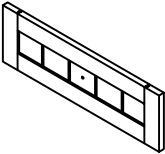
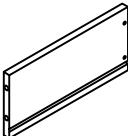



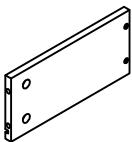
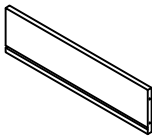
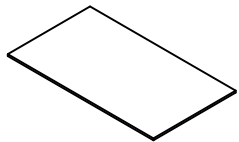
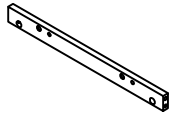

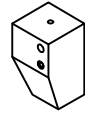

# PART LIST

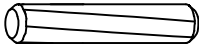
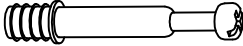
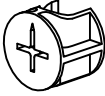
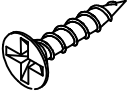
<p>①</p>  <p>1 pcs</p>	<p>②</p>  <p>1 pcs</p>	<p>③</p>  <p>1 pcs</p>
<p>④</p>  <p>1 pcs</p>	<p>⑤</p>  <p>1 pcs</p>	<p>⑥</p>  <p>3 pcs</p>
<p>⑦</p>  <p>2 pcs</p>	<p>⑧</p>  <p>2 pcs</p>	<p>⑨</p>  <p>4 pcs</p>
<p>⑩</p>  <p>2 pcs</p>	<p>⑪</p>  <p>2 pcs</p>	<p>⑫</p>  <p>1 pcs</p>
<p>⑬</p>  <p>1 pcs</p>	<p>⑭</p>  <p>1 pcs</p>	<p>⑮</p>  <p>1 pcs</p>
<p>⑯</p>  <p>1 pcs</p>	<p>⑰</p>  <p>1 pcs</p>	<p>⑱</p>  <p>1 pcs</p>
<p>⑲</p>  <p>1 pcs</p>	<p>⑳</p>  <p>1 pcs</p>	<p>㉑</p>  <p>1 pcs</p>

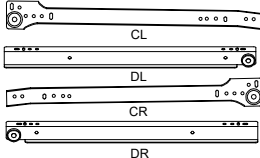
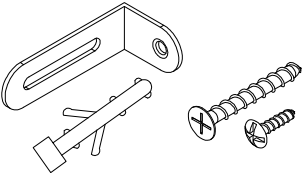
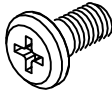
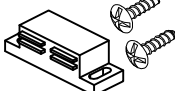
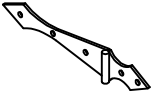
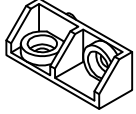
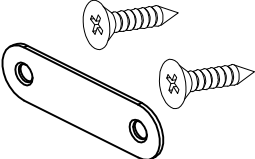
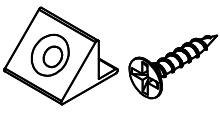
# PART LIST

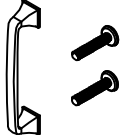

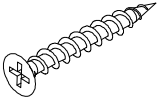
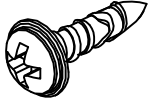
<p><b>22</b></p>  <p><b>1 pcs</b></p>	<p><b>23</b></p>  <p><b>1 pcs</b></p>	<p><b>24</b></p>  <p><b>1 pcs</b></p>
<p><b>25</b></p>  <p><b>2 pcs</b></p>	<p><b>26</b></p>  <p><b>1 pcs</b></p>	<p><b>27</b></p>  <p><b>4 pcs</b></p>

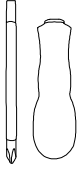
# HARDWARE LIST

<p><b>A X48+2</b></p>  <p>Ø8X30MM</p>	<p><b>B X42+2</b></p> 	<p><b>C X38+2</b></p>  <p>Ø15X12MM</p>
<p><b>D X8+1</b></p>  <p>Ø3X12MM</p>	<p><b>E X4</b></p>  <p>Ø4X35MM</p>	<p><b>F X1</b></p> 
<p><b>G X2</b></p> 	<p><b>H X12+1</b></p>  <p>Ø15X12MM</p>	<p><b>I X1</b></p> 
<p><b>J X4</b></p> 	<p><b>K X6</b></p> 	<p><b>L X2</b></p> 
<p><b>M X8</b></p> 	<p><b>N X1</b></p> 	<p><b>O X2</b></p> 
<p><b>P X16+1</b></p> 	<p><b>Q X4</b></p>  <p>Ø15X10MM</p>	<p><b>R X8+1</b></p>  <p>Ø4X50MM</p>
<p><b>S X24+1</b></p>  <p>Ø3.5X14MM</p>	<p><b>T X2</b></p> 	

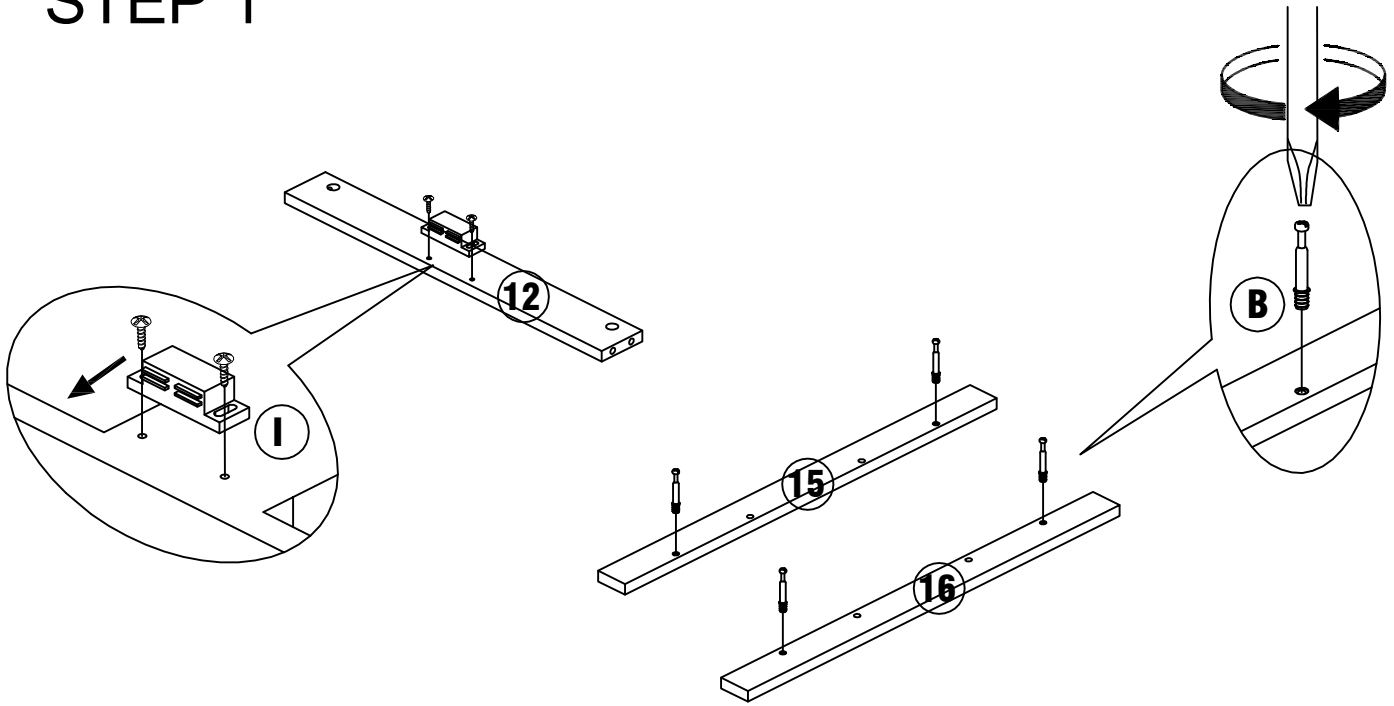

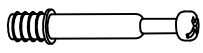
# STEP 1

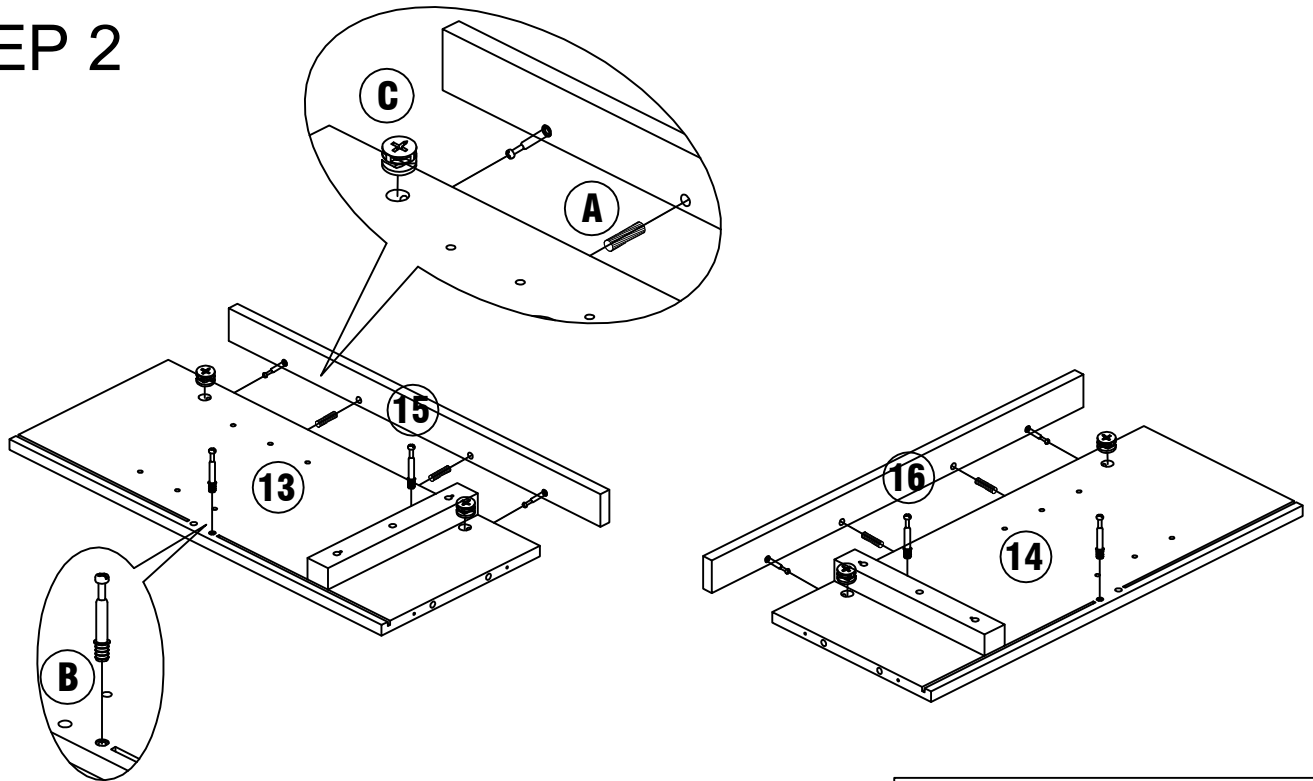

<b>B</b>		<b>X4</b>
<b>I</b>		<b>X1</b>

# STEP 2

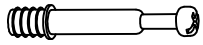

<b>A</b>		<b>X4</b>
<b>B</b>		<b>X4</b>
<b>C</b>		<b>X4</b>

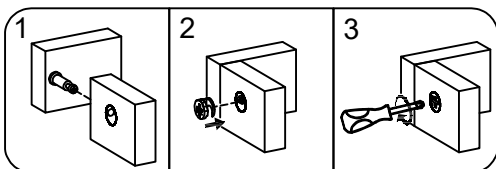

# STEP 3

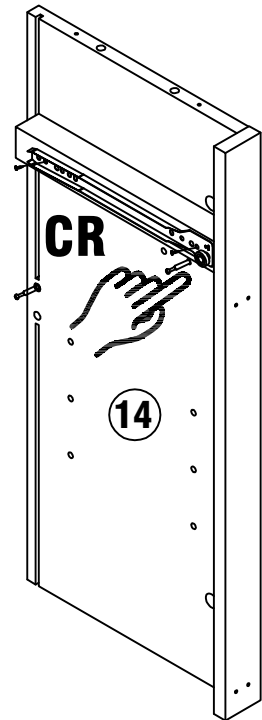
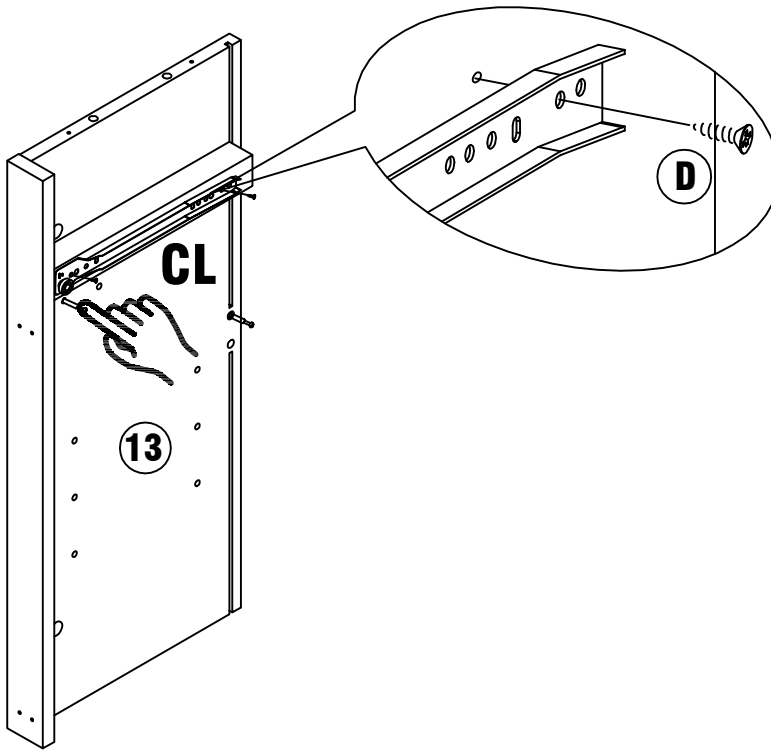
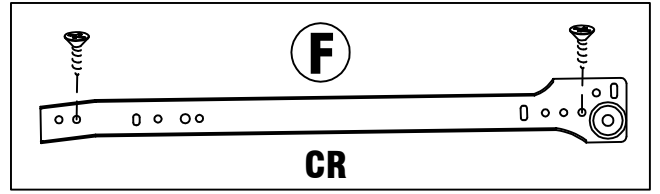
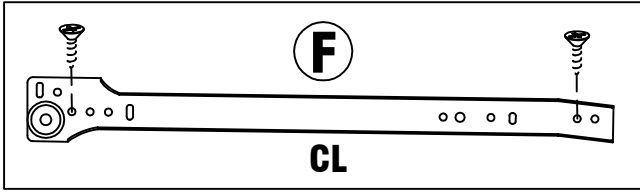

<b>D</b>		<b>X4</b>
<b>F</b>		<b>X1</b>

# STEP 4

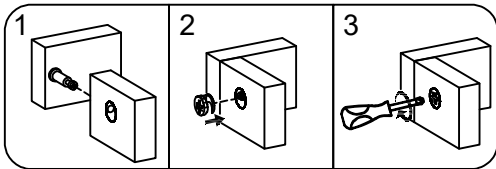
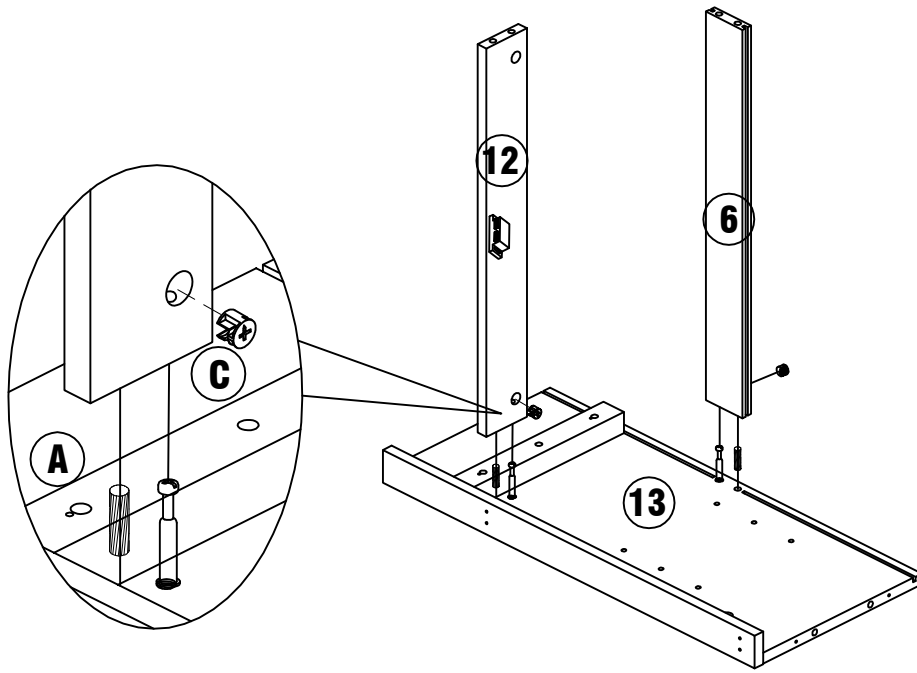

<b>A</b>		<b>X2</b>
<b>C</b>		<b>X2</b>

# STEP 5

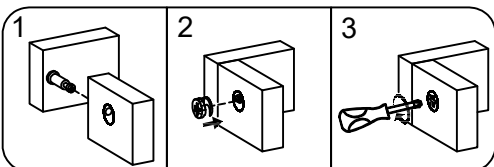
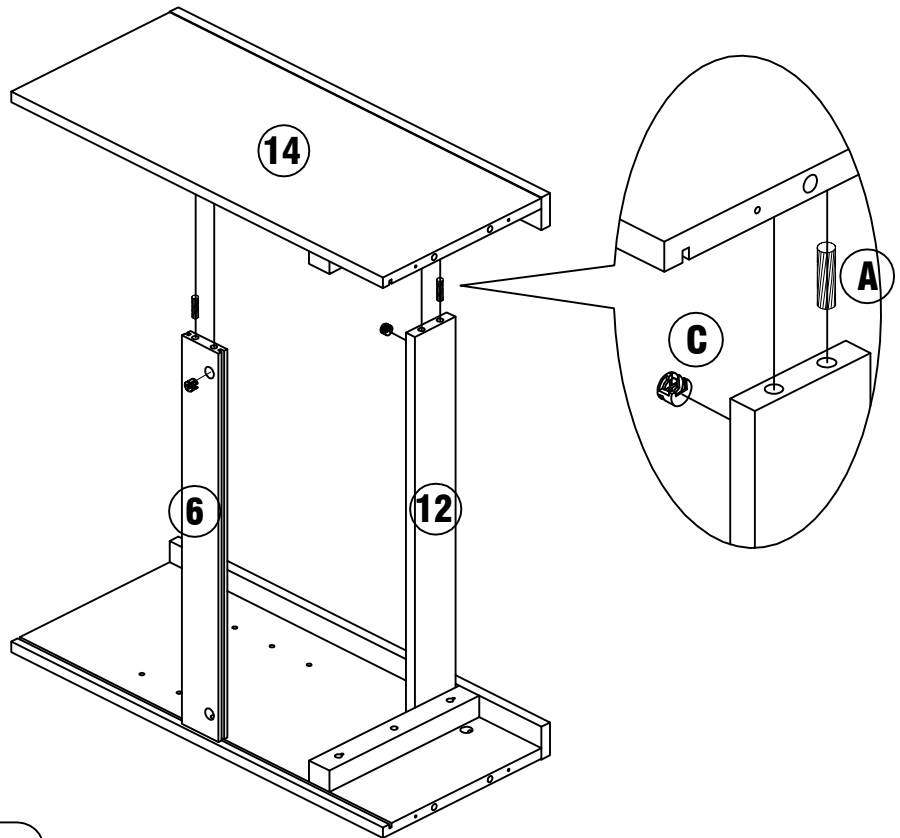

<b>A</b>		<b>X2</b>
<b>C</b>		<b>X2</b>

# STEP 6

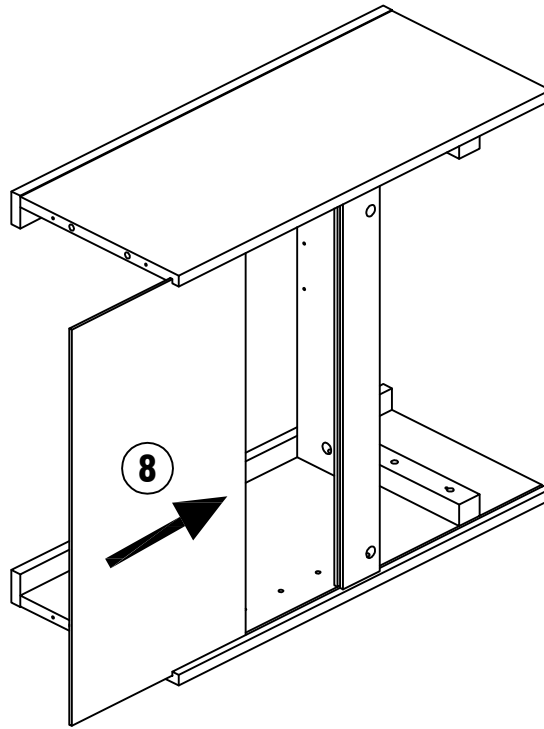

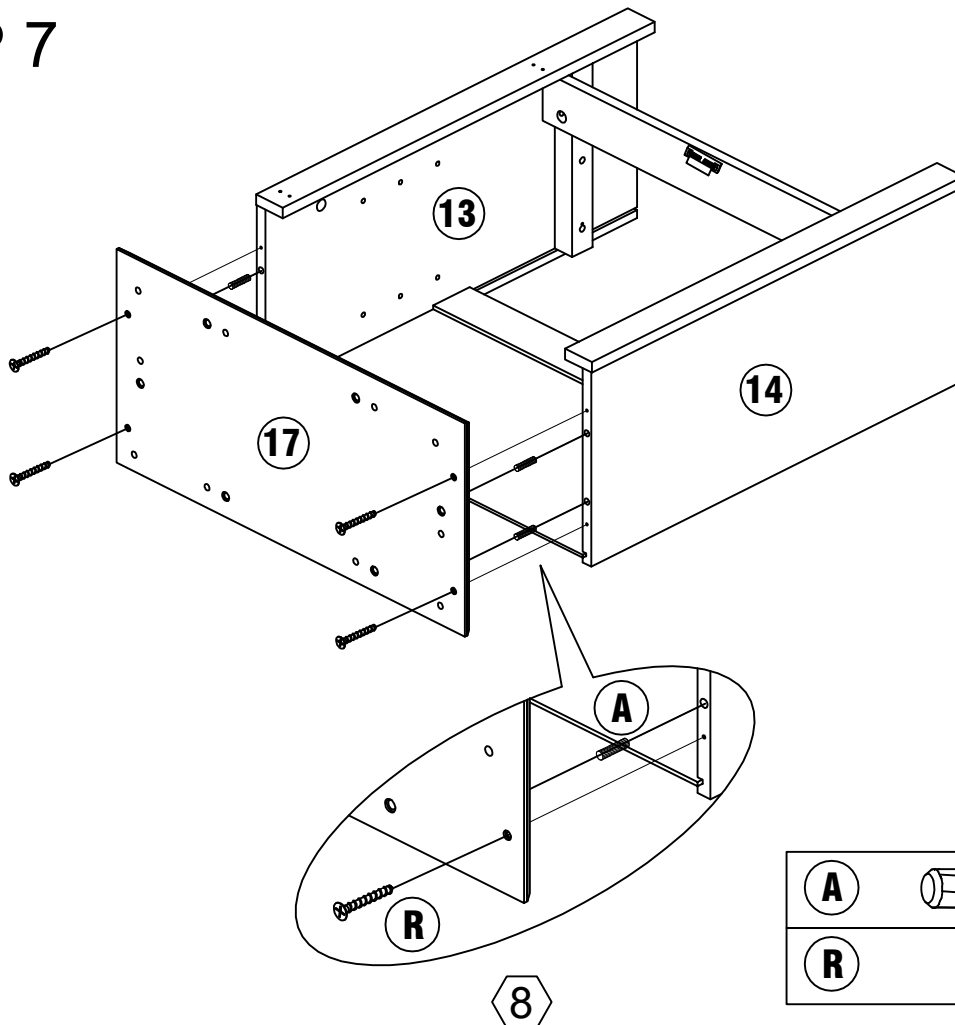

# STEP 7

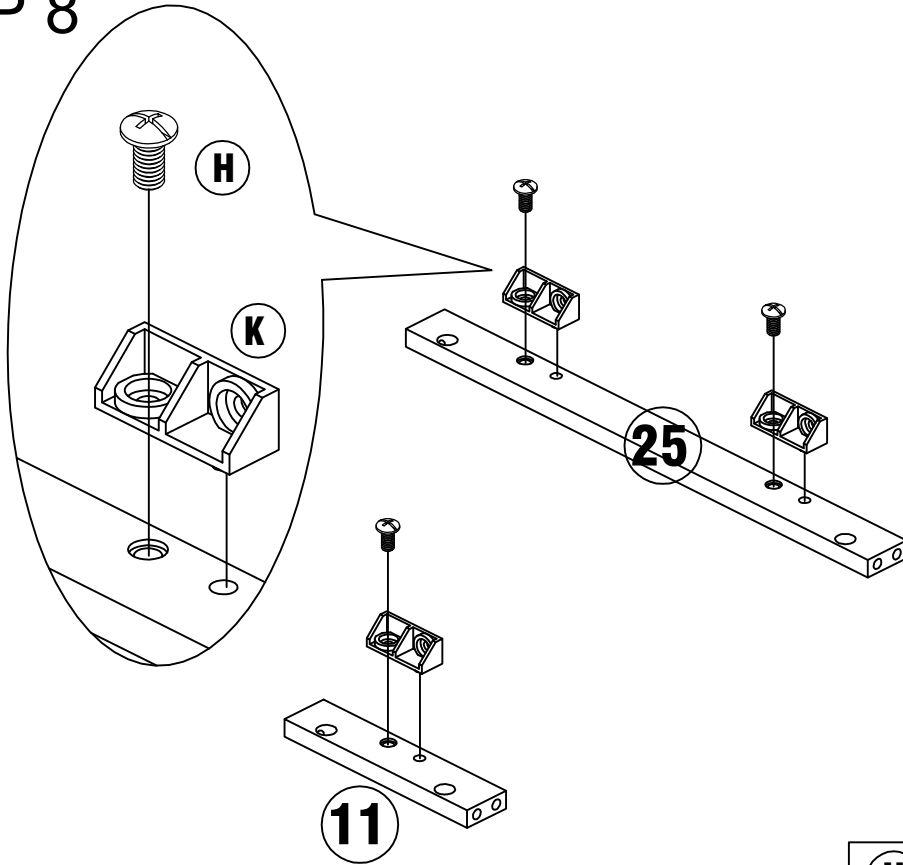

# STEP 8



**X2**

<b>H</b>		<b>X6</b>
<b>K</b>		<b>X6</b>

# STEP 9

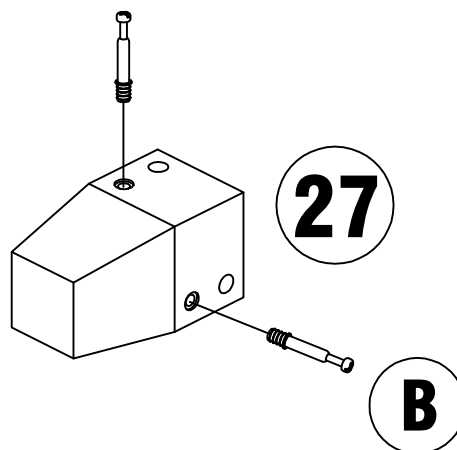

**X4**

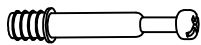

<b>B</b>		<b>X8</b>
----------	---	-----------

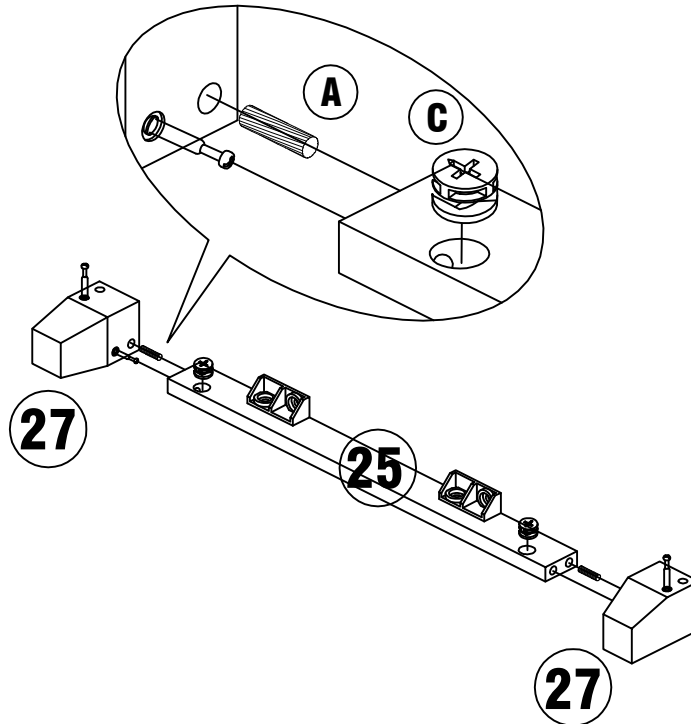
# STEP 10



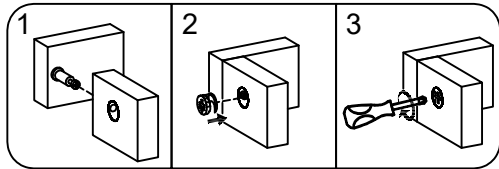

**X2**

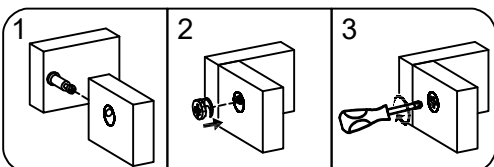
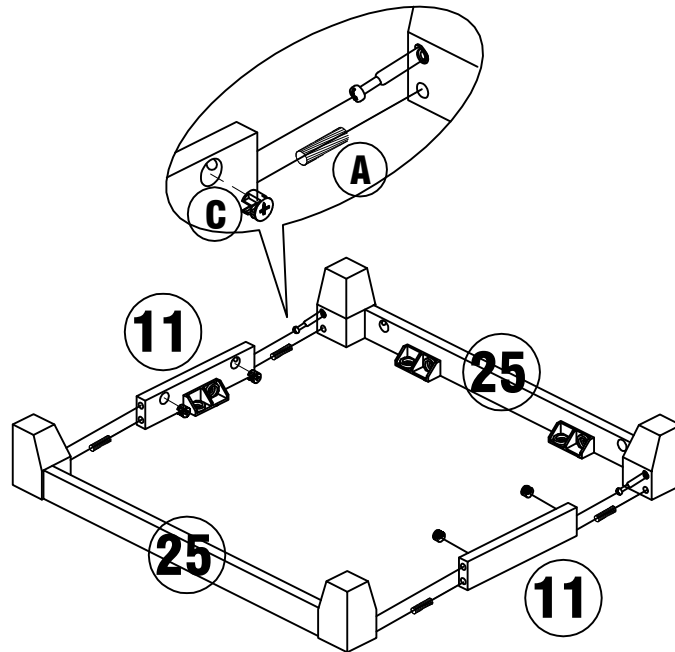

<b>A</b>		<b>X4</b>
<b>C</b>		<b>X4</b>

# STEP 11

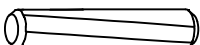

<b>A</b>		<b>X4</b>
<b>C</b>		<b>X4</b>

# STEP 12

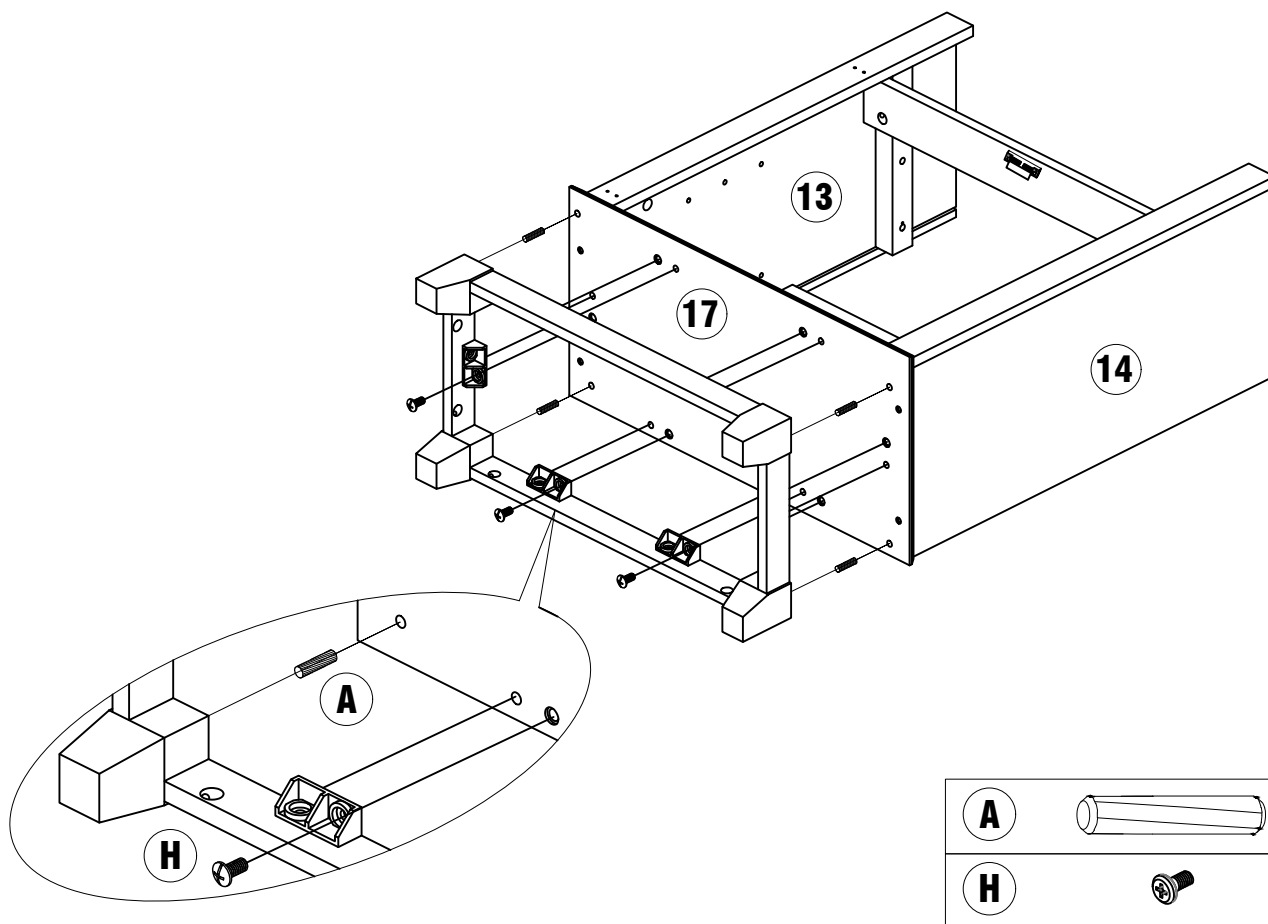

# STEP 13

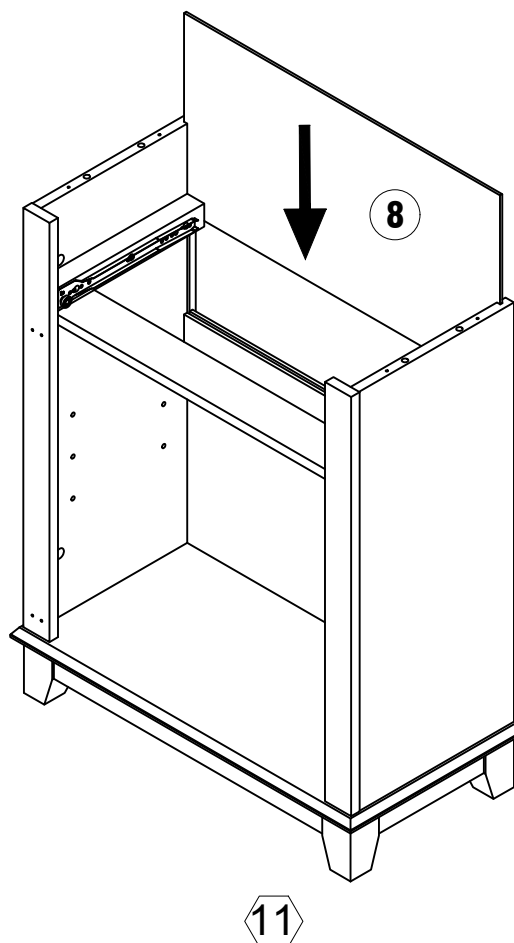

# STEP 14

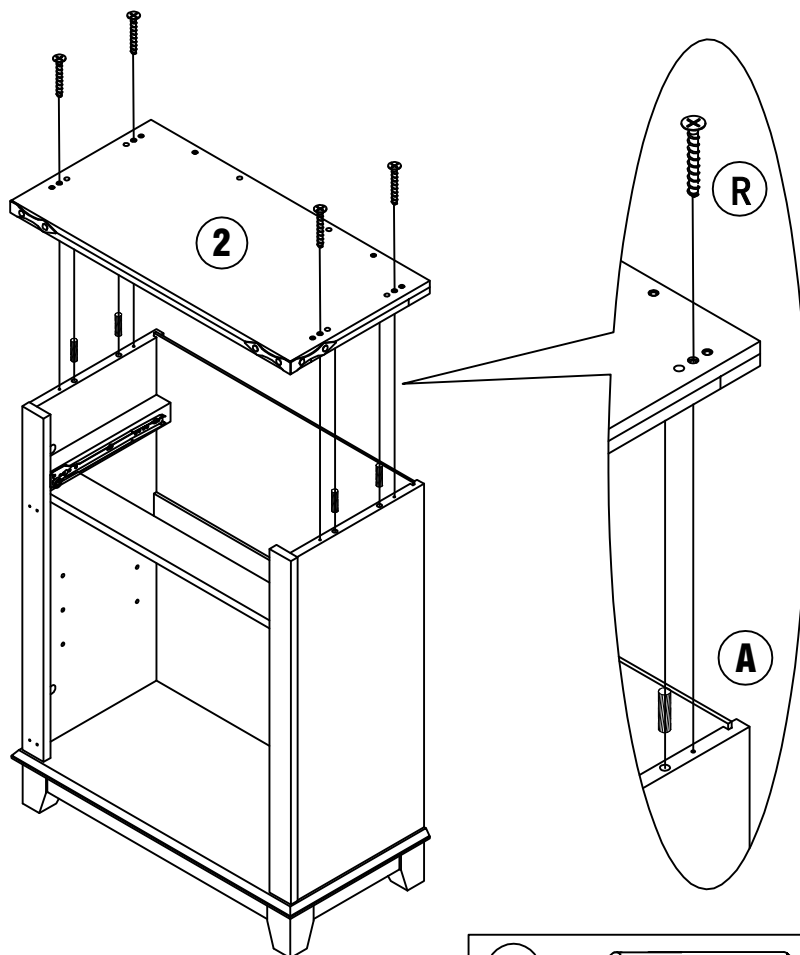

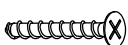
<b>A</b>		<b>X4</b>
<b>R</b>		<b>X4</b>

# STEP 15

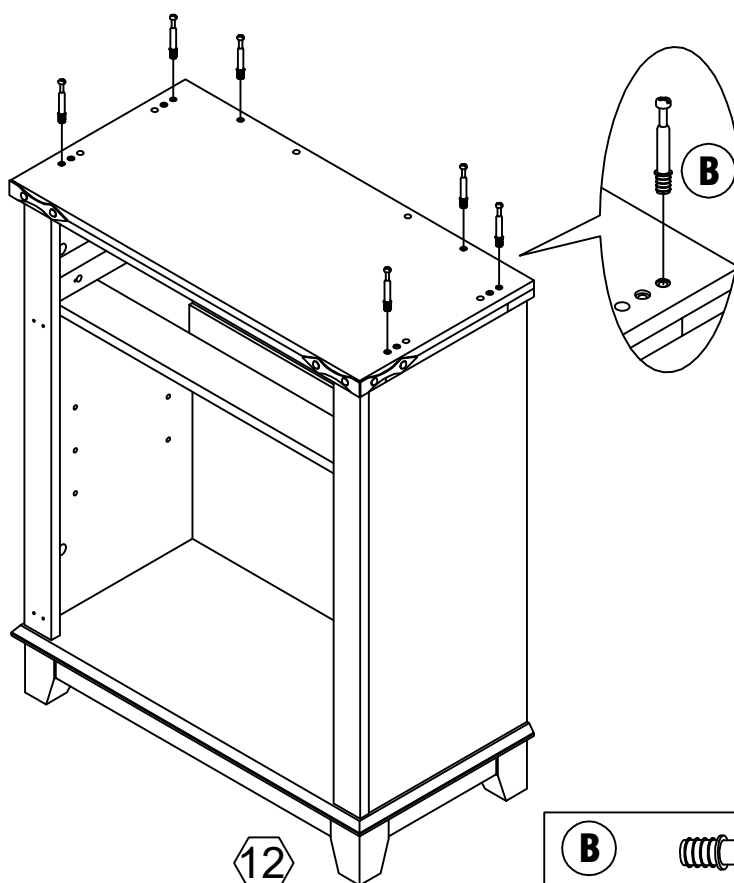

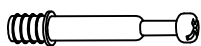
<b>B</b>		<b>X6</b>
----------	---	-----------

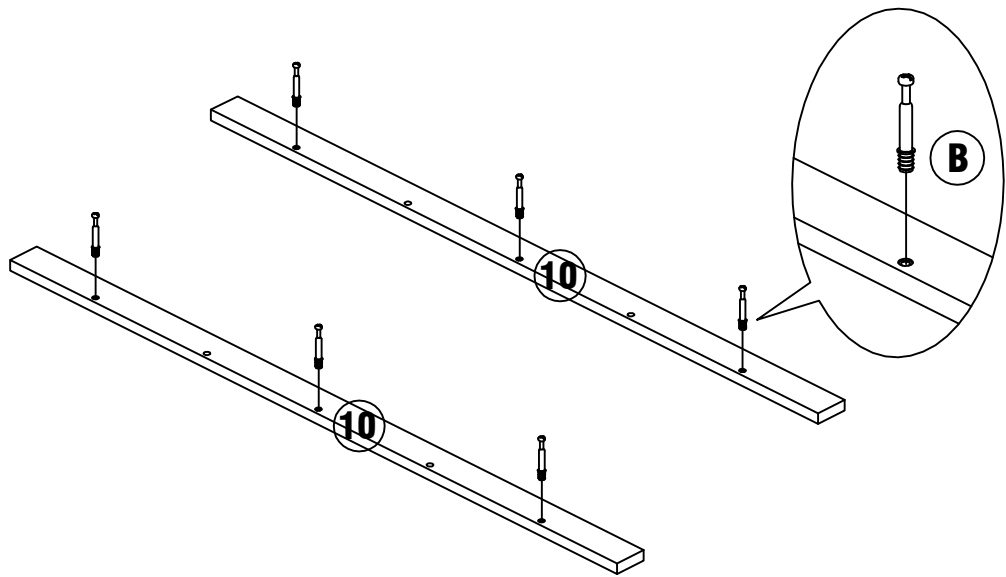

# STEP 16

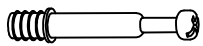

<b>B</b>		<b>X6</b>
----------	---	-----------

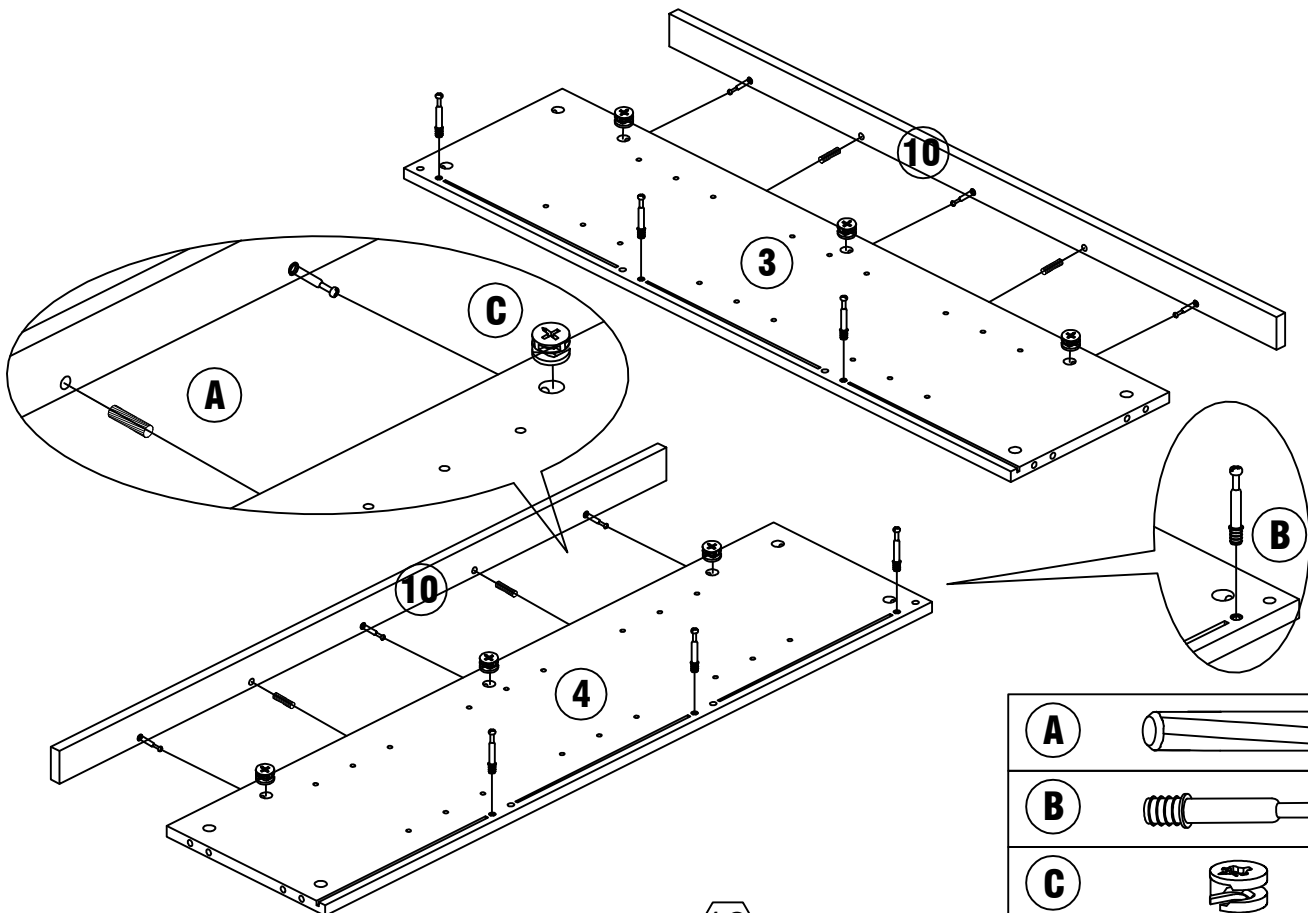
# STEP 17

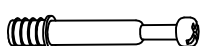

<b>A</b>		<b>X4</b>
<b>B</b>		<b>X6</b>
<b>C</b>		<b>X6</b>

# STEP 18

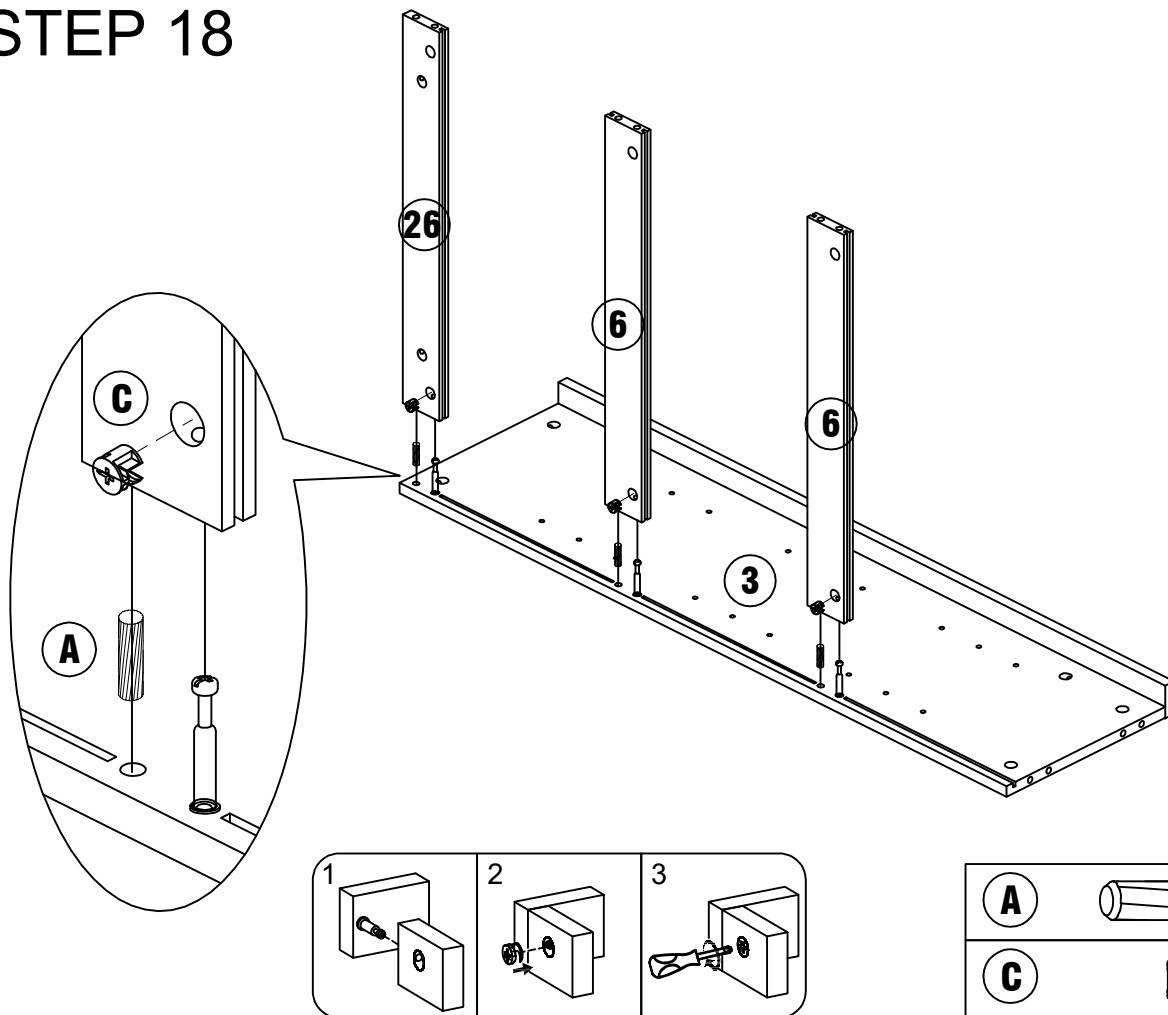

# STEP 19

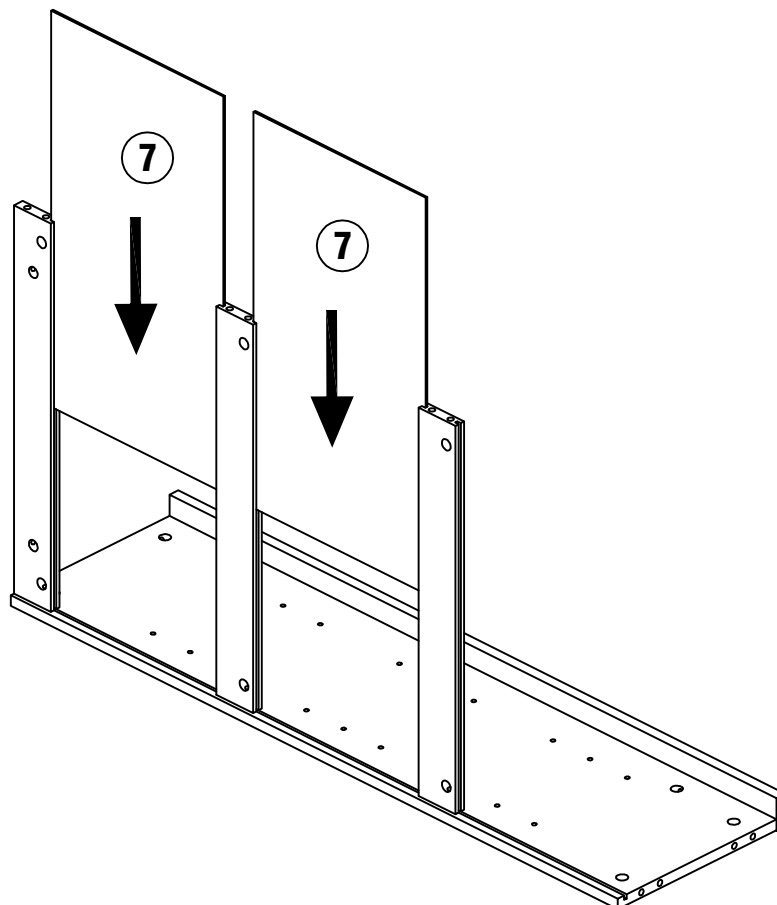

# STEP 20

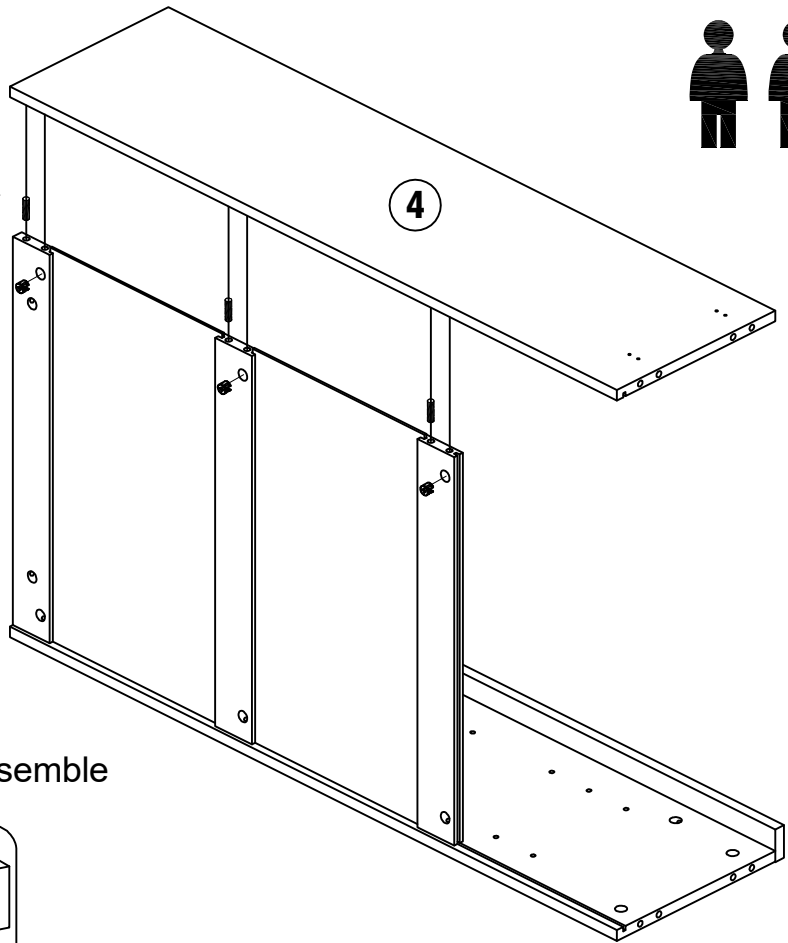
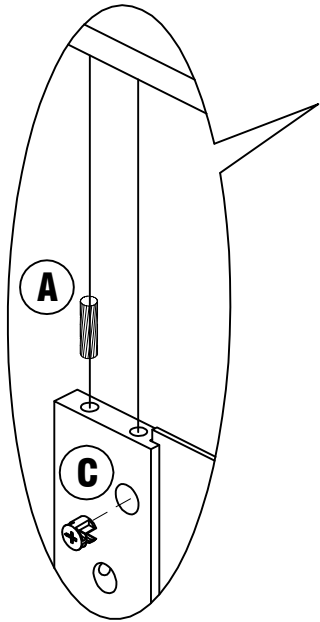
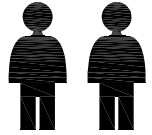

Attention:  
Two people are required to assemble

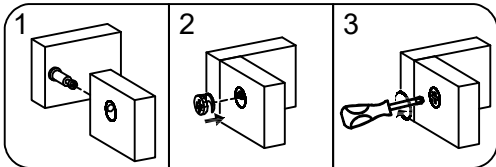

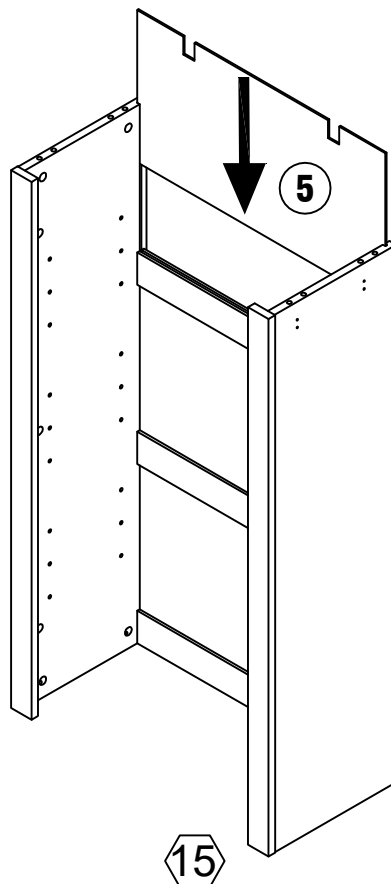

<b>A</b>		<b>X3</b>
<b>C</b>		<b>X3</b>

# STEP 22



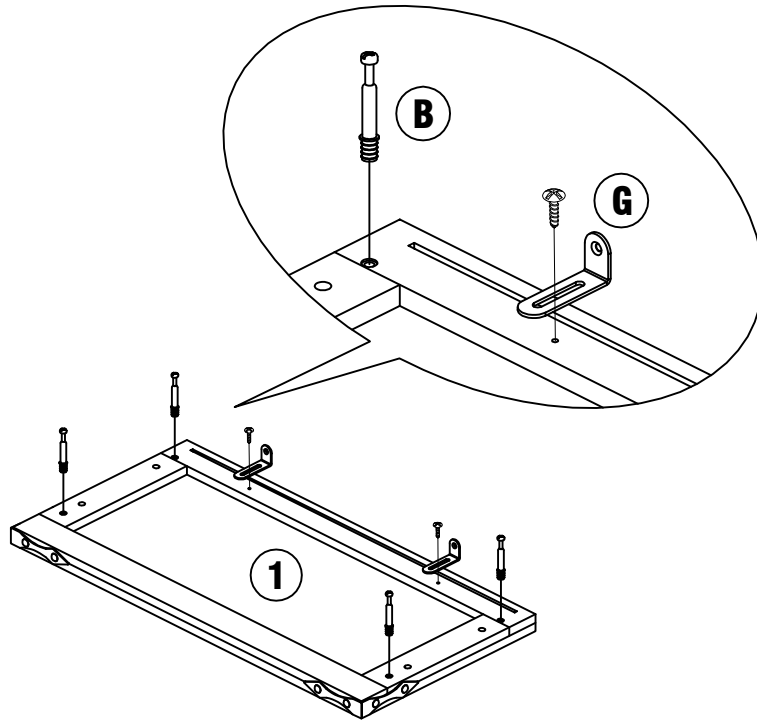

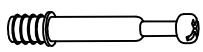
# STEP 23

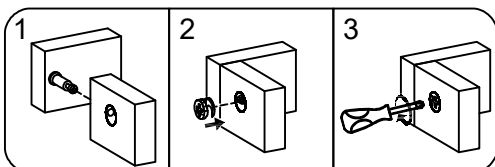
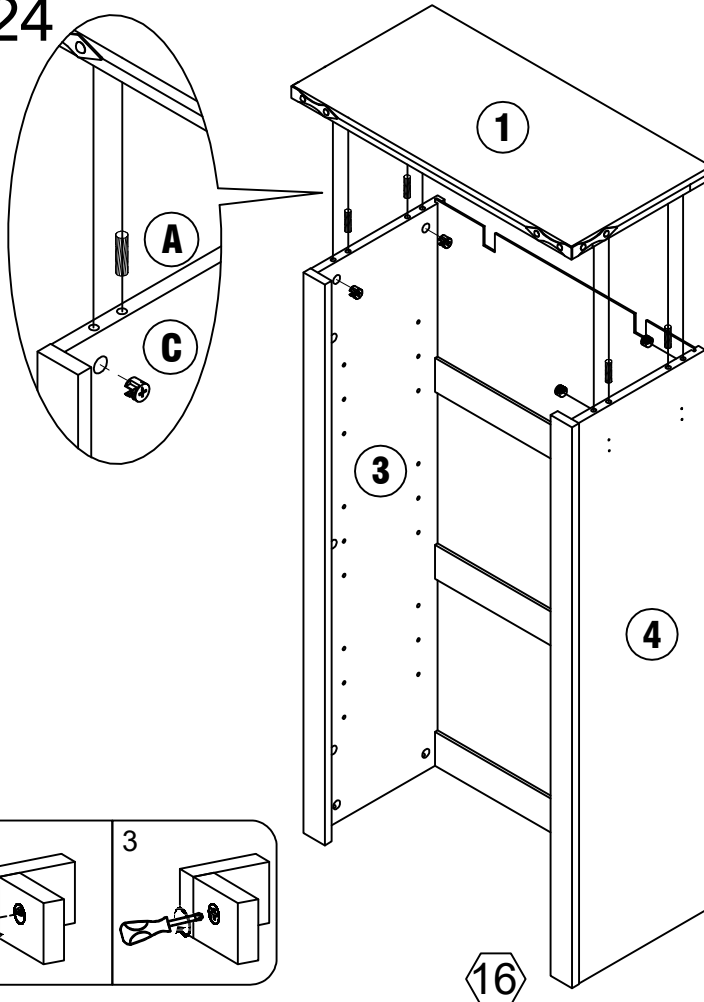

<b>B</b>		<b>X4</b>
<b>G</b>		<b>X2</b>

# STEP 24

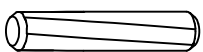

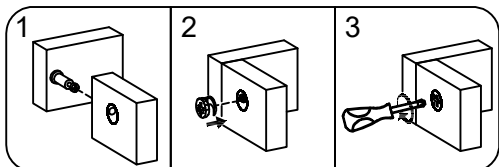
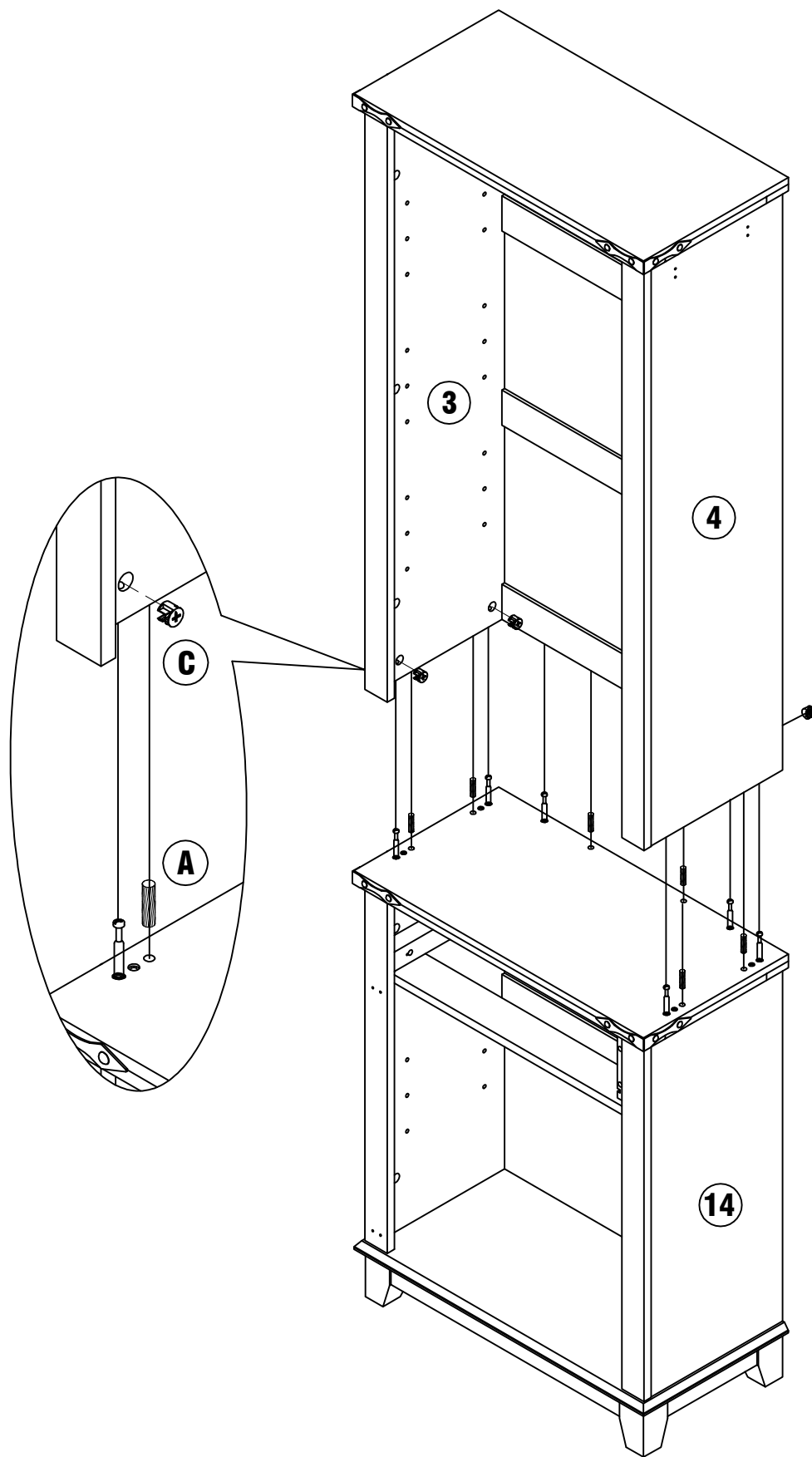

<b>A</b>		<b>X4</b>
<b>C</b>		<b>X4</b>

# STEP 25



17

<b>A</b>		<b>X6</b>
<b>C</b>		<b>X6</b>

# STEP 26

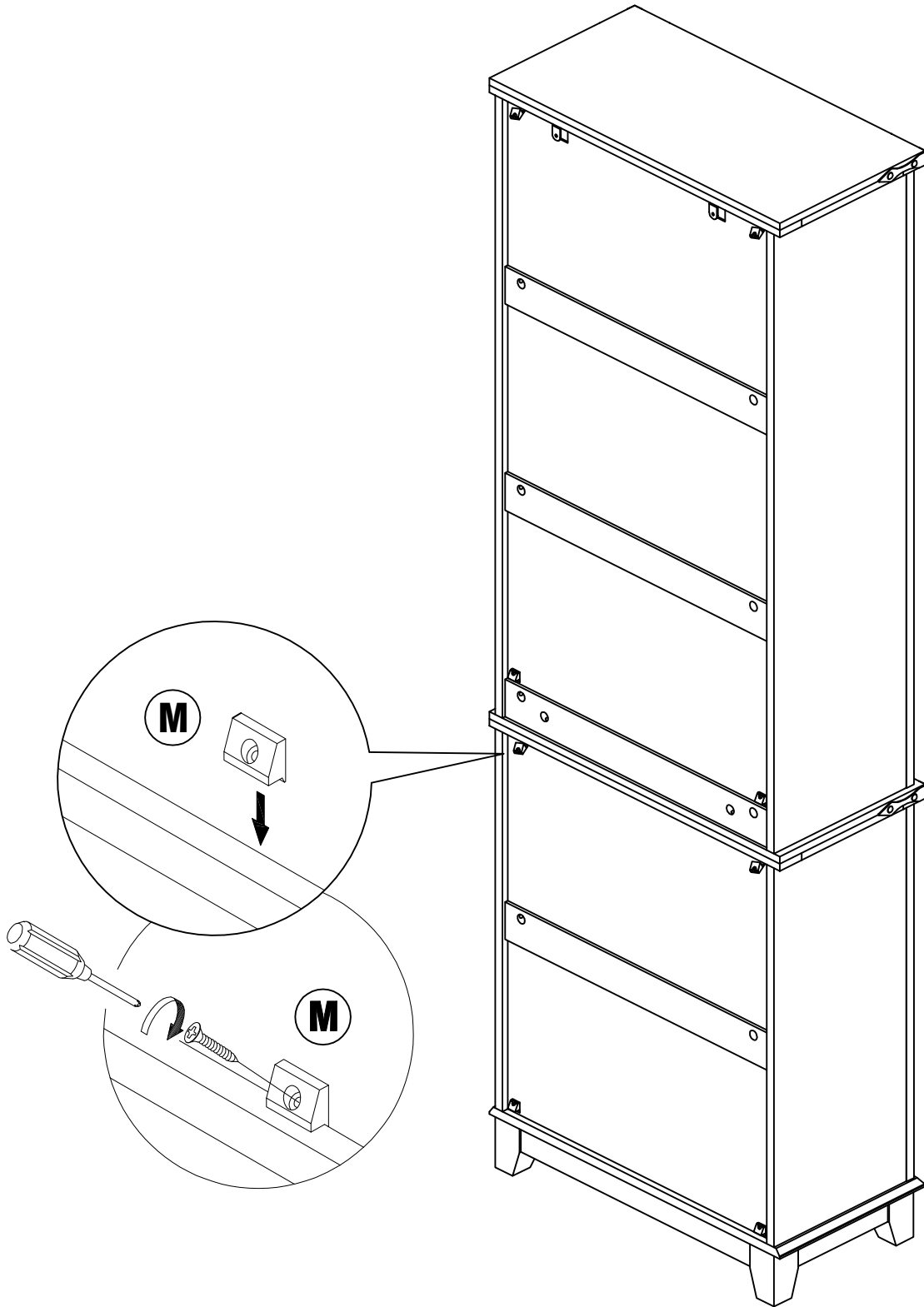

# STEP 27

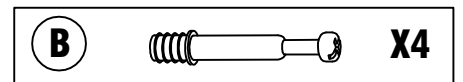
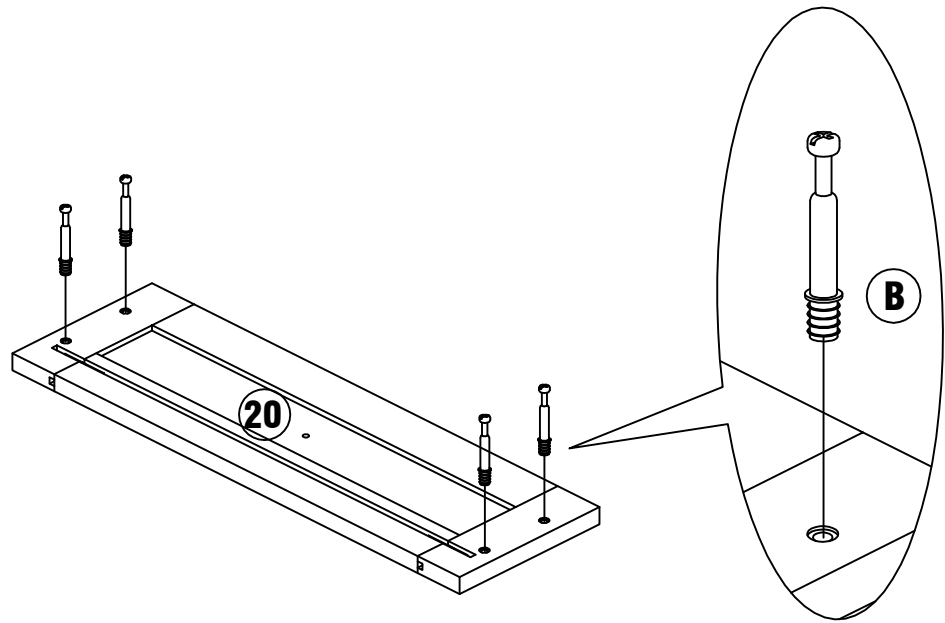

# STEP 28

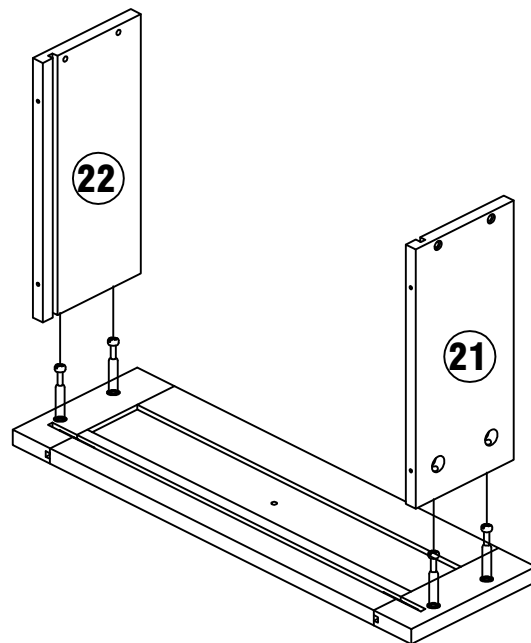

# STEP 29

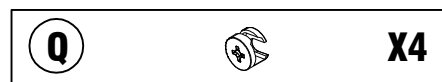
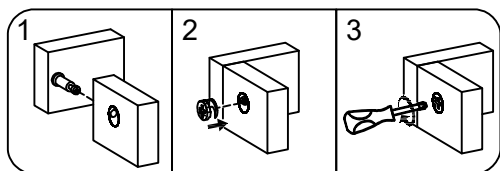
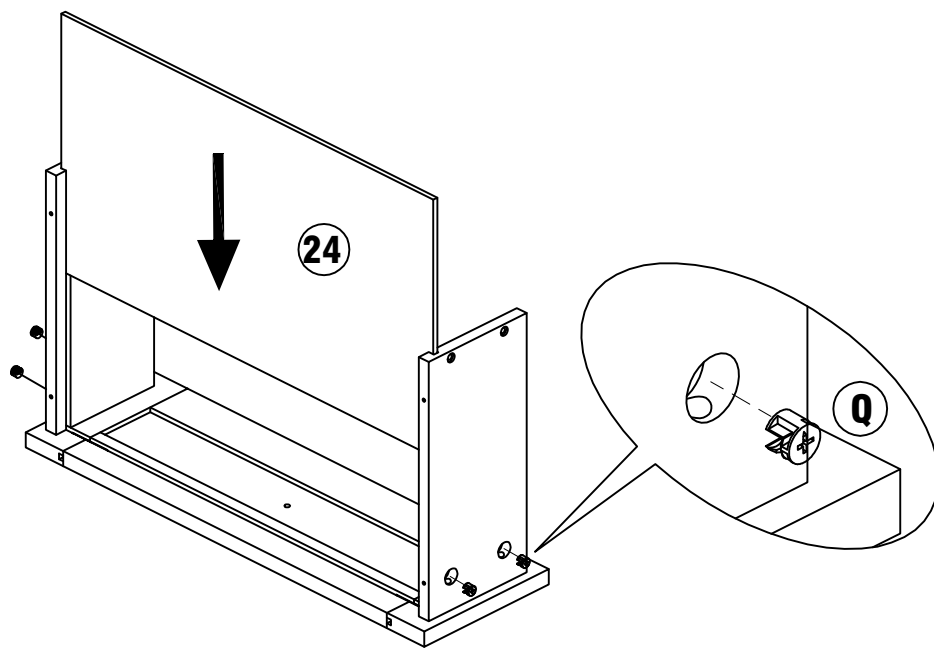

# STEP 30

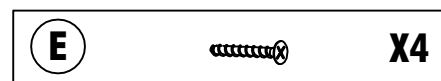
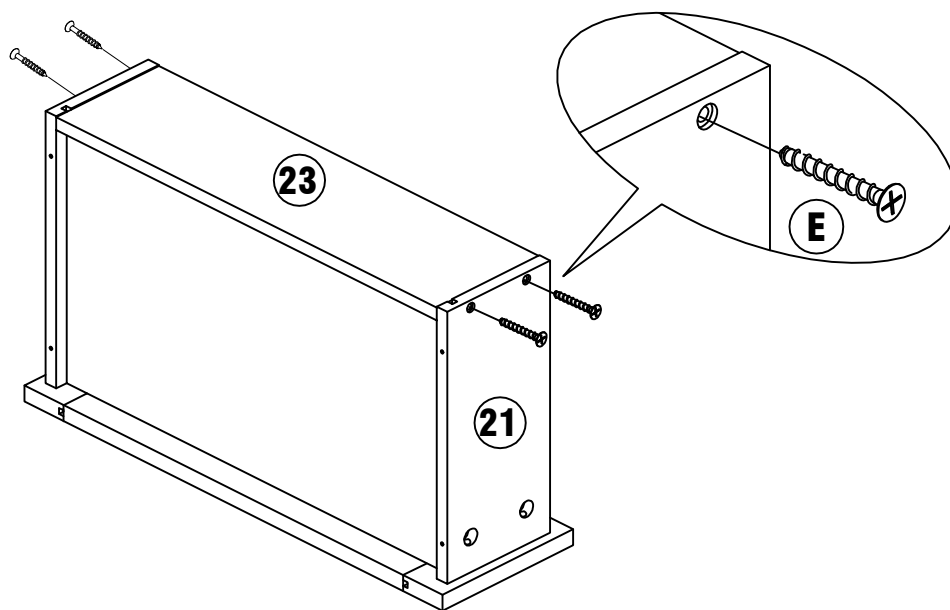

# STEP 31

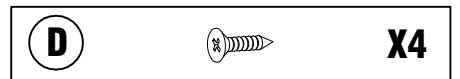
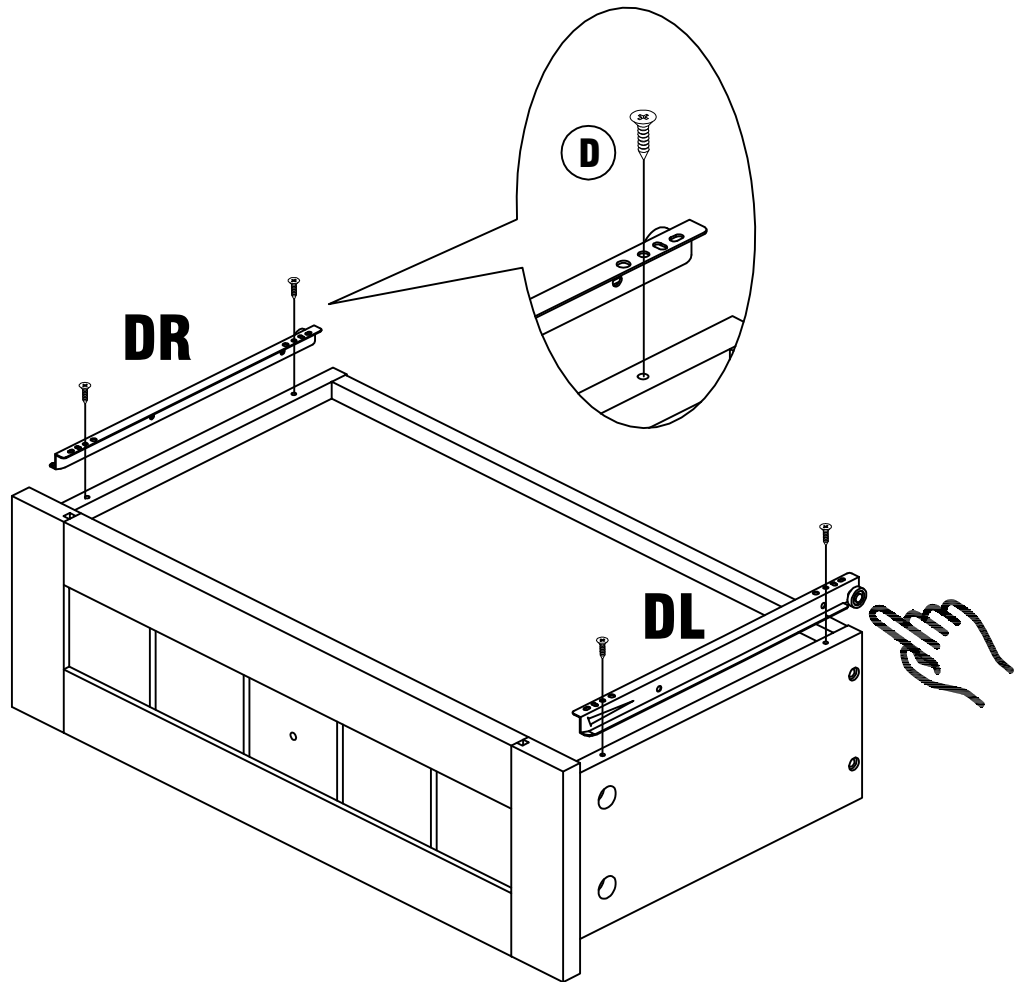
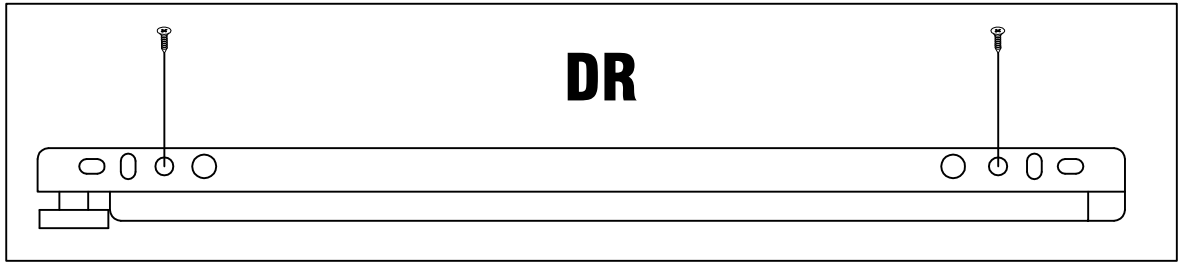
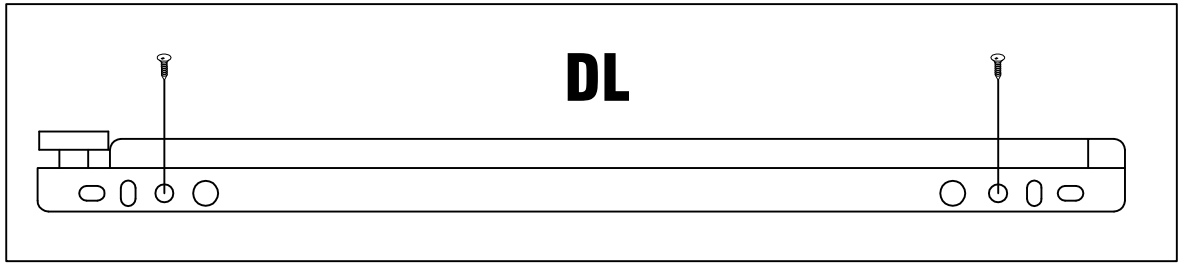

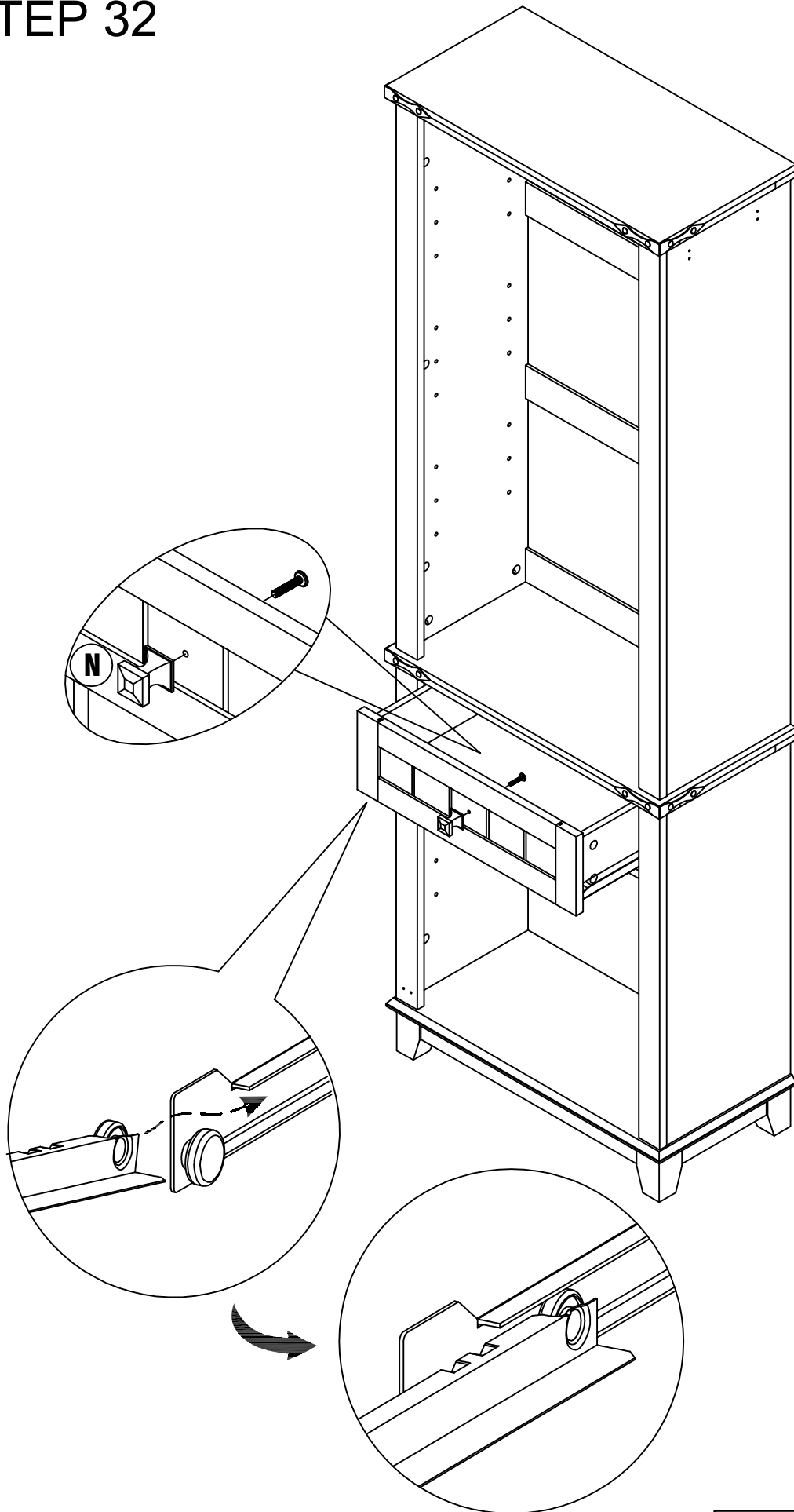

# STEP 32

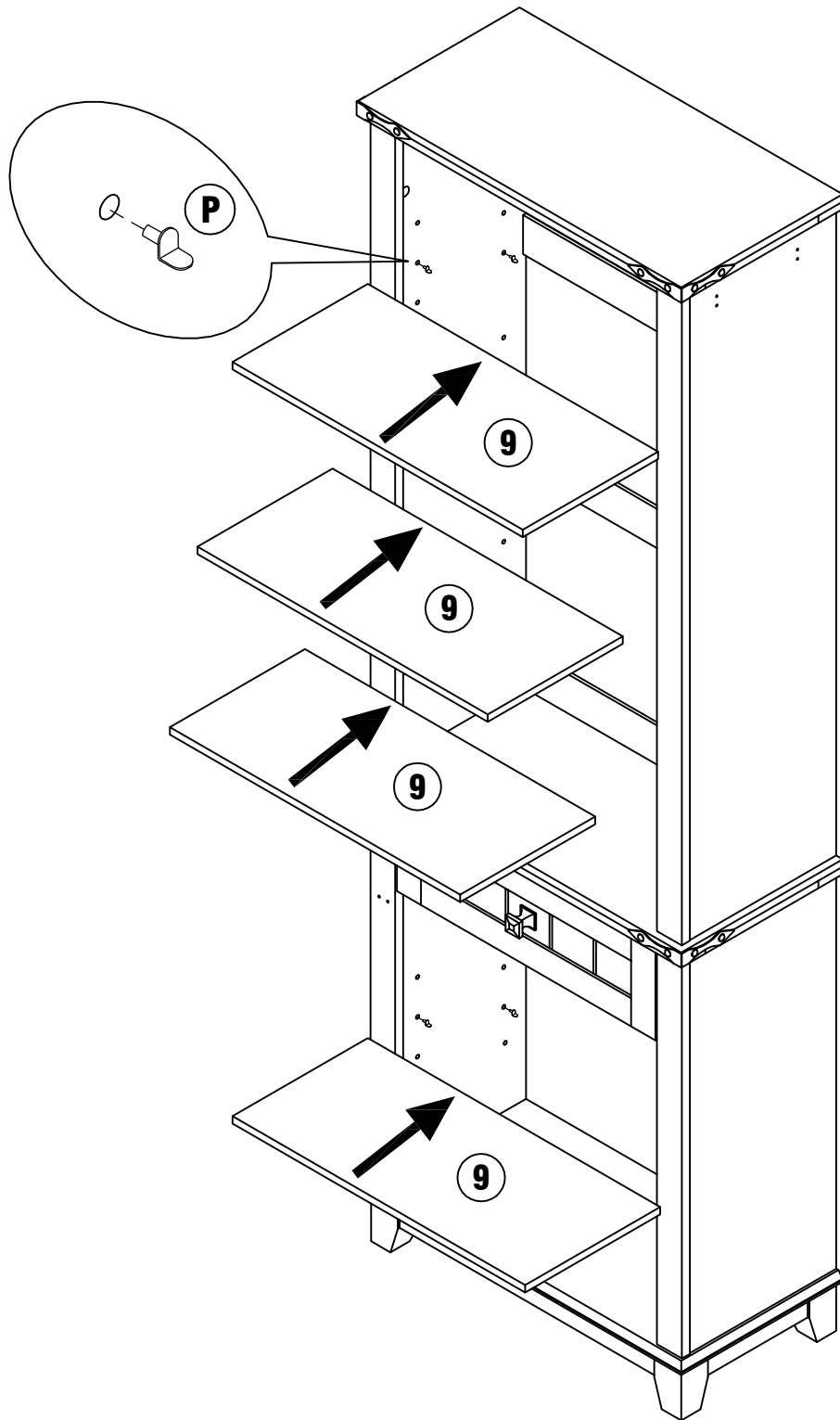

N		X1
---	--	----

# STEP 33



<b>P</b>		<b>X16</b>
----------	---	------------

# STEP 34

J		X4
L		X2
O		X2
S		X12

# STEP 35

S		X12
T		X2

# STEP 36

