

# HEADBOARD

## ASSEMBLY INSTRUCTIONS

Before assembling your headboard, please read through these instructions carefully and familiarize yourself with the different parts.

**ATTENTION!** If you receive a damaged or defective item, please contact us



### PARTS LIST

- 1 HEADBOARD PANEL 1 PC
- 2 LEFT LEG 1 PC
- 3 RIGHT LEG 1 PC

Instructions apply for bed sizes  
TWIN > FULL > QUEEN

### HARDWARE

- A** Wooden dowel - 4 pcs  
Spare - 1 pc
  - B** JCB M6 X 35mm (1 3/8") - 4 pcs  
Spare - 1 pc
  - C** JCB M8 X 15mm (5/8") - 4 pcs
  - G** Allen wrench - 1 pc  
Spare - 1 pc
- Assembly headboard to open bed frame*

- HARDWARE FOR METAL BED FRAME**
- D** JCB M6 X 25mm (1") - 4 pcs  
Spare - 1 pc
  - E** Flat washer - 4 pcs  
Spare - 1 pc
  - F** Split washer - 4 pcs  
Spare - 1 pc

NOTE: WE INCLUDE SPARE HARDWARE IN CASE DAMAGE OCCURS DURING ASSEMBLY.

### Step 1

Attach the left leg (2) and right leg (3) to headboard panel (1), using wooden dowels (A) and JCB M6 X 35mm (B). Tighten with the Allen wrench (G).

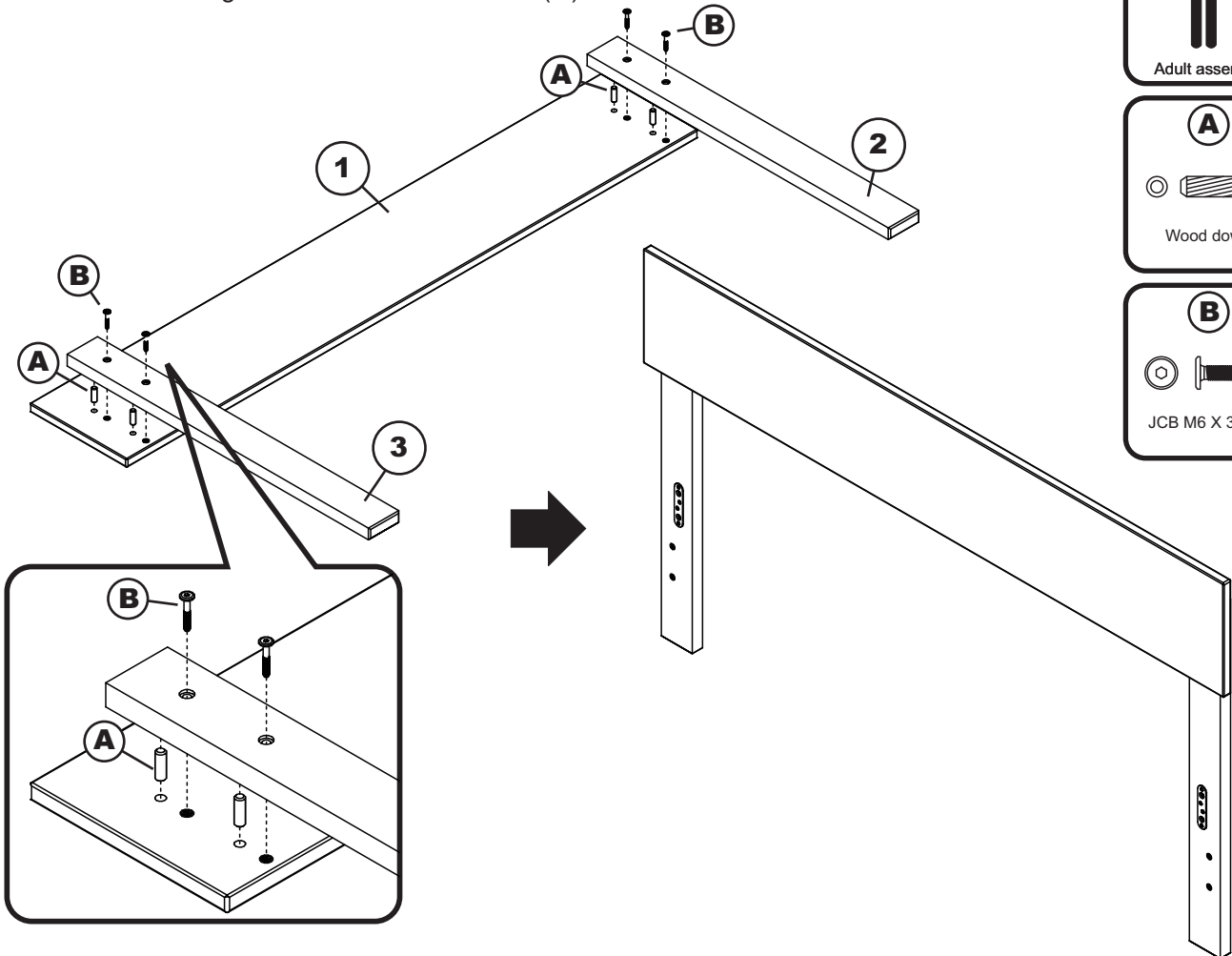
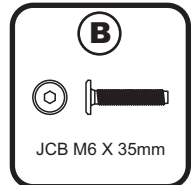
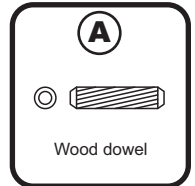

**FOR BED FRAME ASSEMBLY** follow assembly instructions included with your bed frame. If you purchased a wood headboard to attach to metal bed frame, please refer to page 2.

# OPEN BED FRAME

## QUEEN

### ASSEMBLY INSTRUCTIONS

Before assembling your bed frame, please read through these instructions carefully and familiarize yourself with the different parts.

**ATTENTION!** If you receive a damaged or defective item, please contact us



#### PARTS LIST

①	<b>FOOT RAIL</b>	<b>1 PC</b>
②	<b>LEFT LEG</b>	<b>1 PC</b>
③	<b>RIGHT LEG</b>	<b>1 PC</b>
④	<b>SIDE RAILS</b>	<b>2 PCS</b>
⑤	<b>SLAT KIT</b>	<b>2 SETS</b>
⑥	<b>SLAT SUPPORT 1</b>	<b>1 PC</b>
⑦	<b>SLAT SUPPORT 2</b>	<b>1 PC</b>
⑧	<b>SUPPORT LEGS</b>	<b>3 PCS</b>

#### HARDWARE

ⓐ	JCB M6 X 110mm (4 3/8") - 2 pcs Spare - 1 pc	ⓔ	JCB M6 X 30mm(1 1/4") - 6pcs
ⓑ	Barrel nut - 2 pcs	ⓕ	Cap nut - 6pcs
ⓒ	JCB M8 X 15mm ( 5/8") - 4 pcs	ⓓ	Allen wrench M6 - 1pc
ⓓ	Wood screw(1 1/4") - 29 pcs Spare - 2 pcs	ⓖ	JCB M8 X 40mm(1 5/8") - 3pcs
		ⓙ	Allen wrench M4 - 1pc Spare - 1pc
		ⓚ	Split washer - 3pcs Spare - 1pc
		Ⓚ	Flat washer - 3pcs Spare - 1pc

NOTE: WE INCLUDE SPARE HARDWARE IN CASE DAMAGE OCCURS DURING ASSEMBLY.

### Step 1

Attach the legs (2) and (3) to foot rail (1), using JCB M6 X 110mm (A) and barrel nut (B).  
Tighten with the Allen wrench M4 (I).

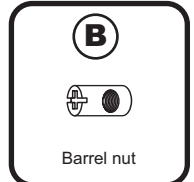
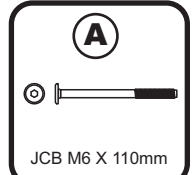
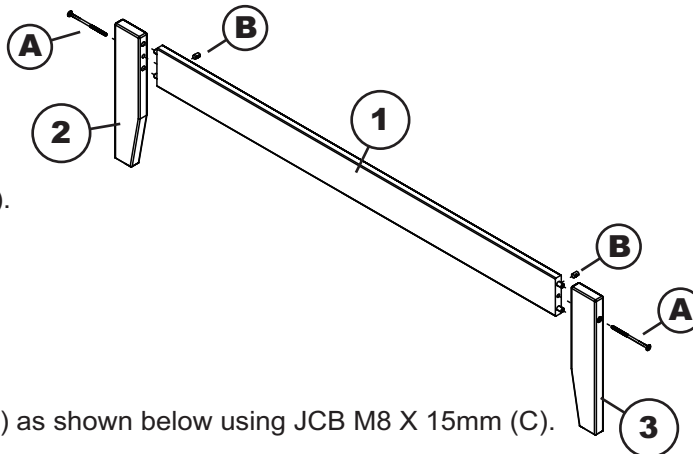

### Step 2

Attach side rails (4) to the foot rail (1) as shown below using JCB M8 X 15mm (C).  
Tighten with Allen wrench M6 (H).

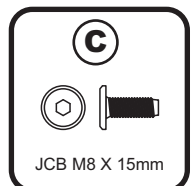
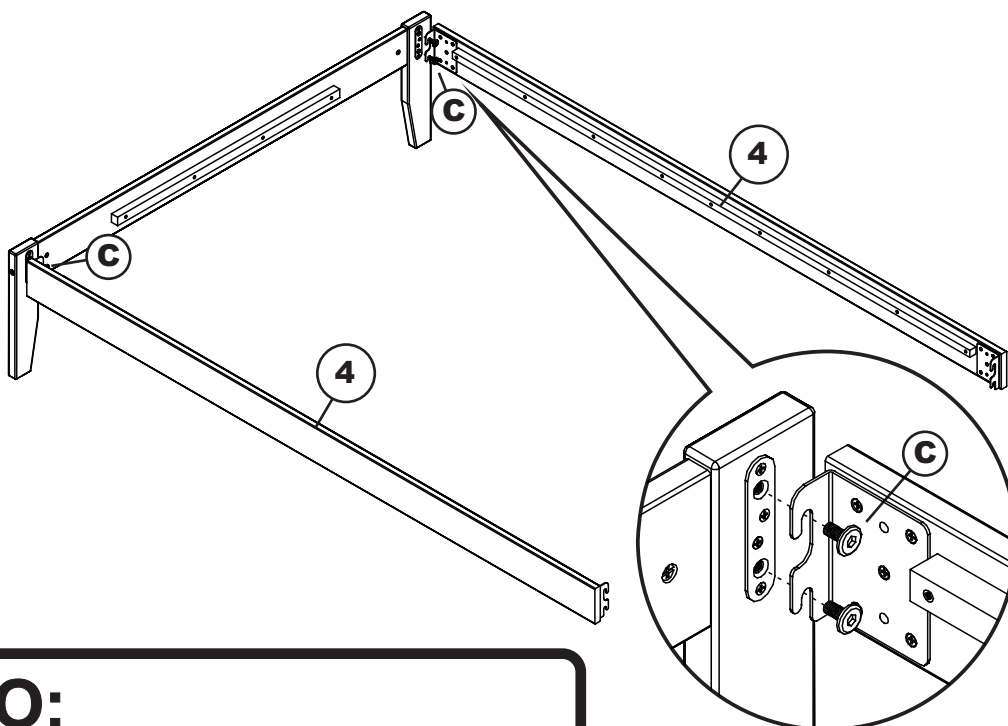

**PO:**

# OPEN BED FRAME

QUEEN



## Step 3

Attach open bed frame to the headboard as shown below using 4 JCB M8 X 15mm bolts that are supplied with your headboard. Tighten with the Allen wrench M6 (H).

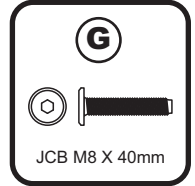
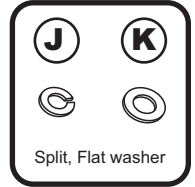
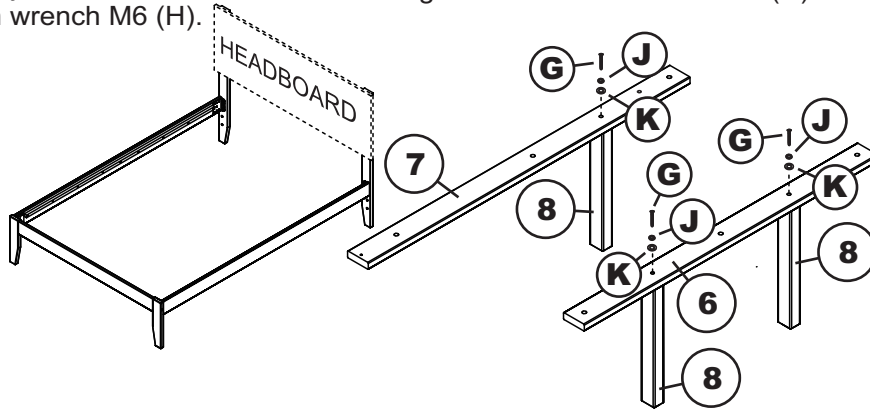
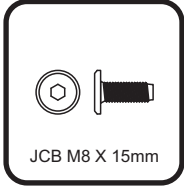

## Step 5

Attach slat support 1(6) and slat support 2 (7) to the slat kit (5) as shown below using JCB M6 X 30mm (E) and cap nut (F). Tighten with Allen wrench M4 (I).

2 legs at headboard section.

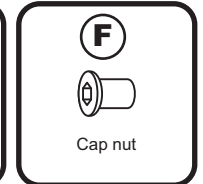
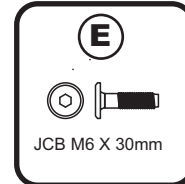
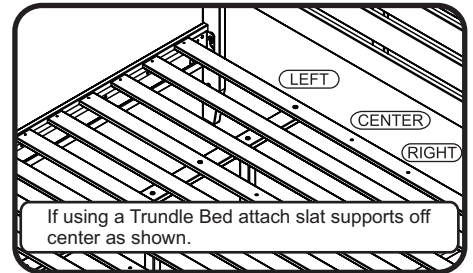
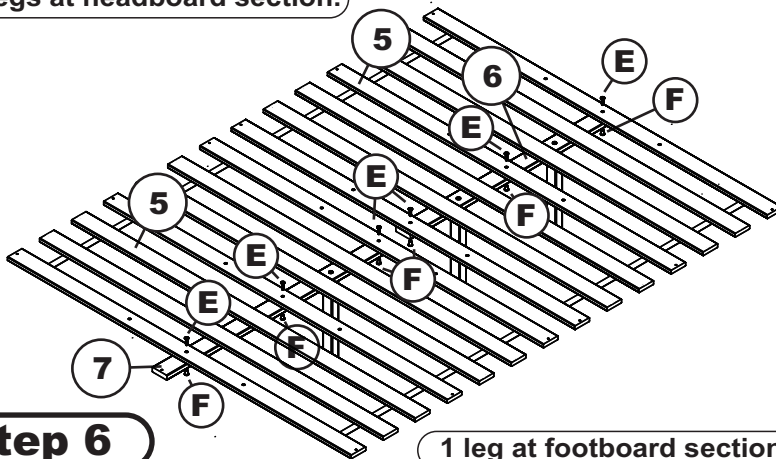

## Step 6

Attach 2 slat kits (5) to the open bed frame as shown below using wood screws 1 1/4" (D). Tighten with Phillips head screw driver. (customer supplied)

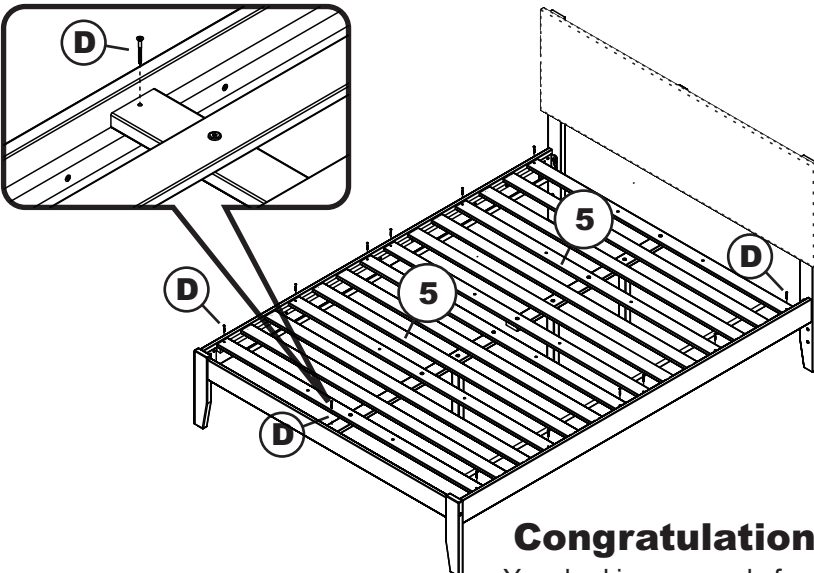

**Congratulations!**

Your bed is now ready for use.

We recommend that you periodically recheck that all screws are tight to ensure lasting safety.