

Owner Manual



Sofa

WARRANTY

We strive to offer high quality product and we also try our best to satisfy each customer that order from us, no matter on products or services as needed. Each customer receives a record of their order, such as the order number or item receipt. For any items that are out of warranty period, you may still be able to purchase the replacement parts from our company if they are available.

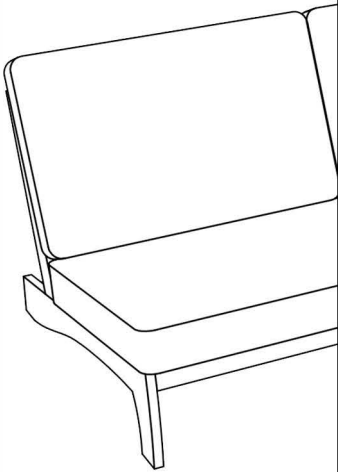

MAINTENANCE AND WARNING

Please read the manual thoroughly
before you start installing.

Please keep the product away from
sharp object.

Packaging and small parts may have
chocking hazard, please keep them away
from children and pets.

Please clean the product according to each
clean code, check the product description
for more information.

Please keep the product away from
fire.

If you have any other questions, please
contact us, we will be glad to help you out.

If the product is placed under direct
sunlight, the pattern or color might fade
away overtime.

Check the product periodically to make
sure everything is secured and tightened.

Always use proper tools for installation.

Do not jump on the product.

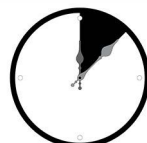

Around 45 min

PRODUCT DESCRIPTION

The waterproof cotton blend fabric keeps you dry and comfortable, even in rainy weather, making this chair perfect for year round outdoor use.

Crafted with a durable solid wood frame, this chair supports up to 400 lbs, offering solid strength for long lasting outdoor enjoyment.

The chair features soft, cushioned seating that adds comfort for hours of relaxation in your garden, patio, or balcony.

Set up is quick and simple, allowing you to enjoy your outdoor seating area without hassle.

This set includes two chairs, making it an ideal choice for couples, guests, or small outdoor gatherings.

EXPLODED VIEW

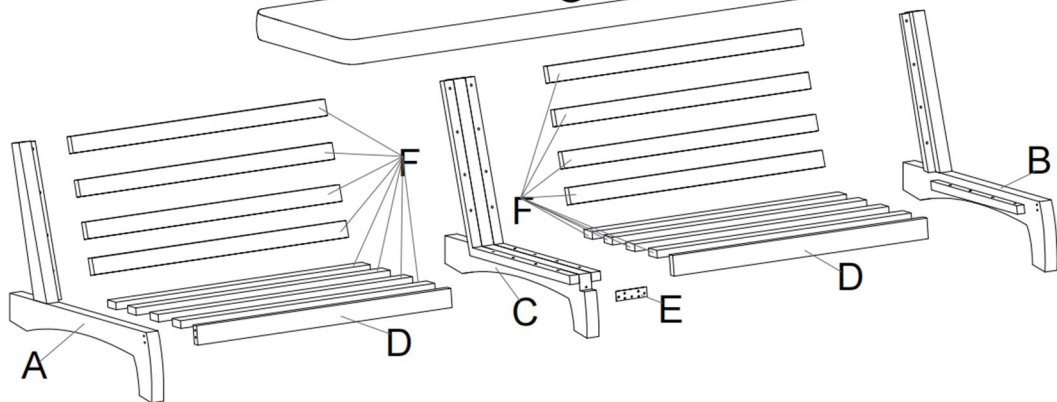
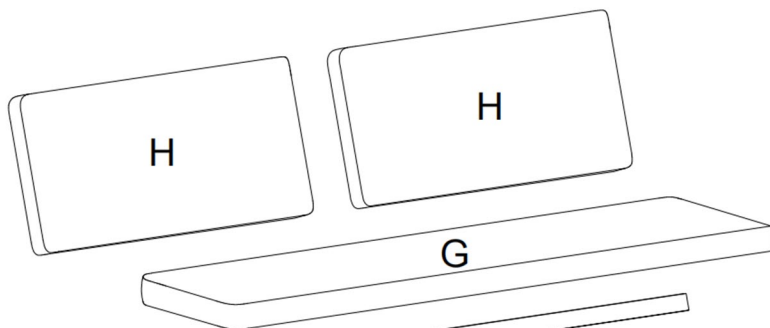
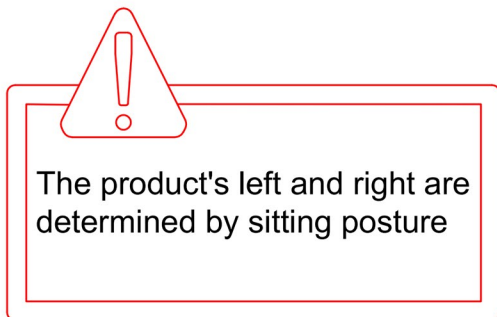
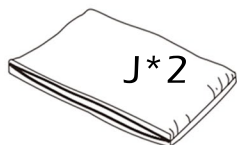
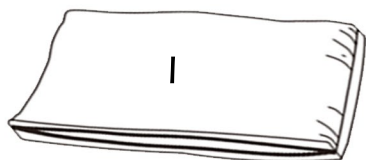

PARTS

Ax1

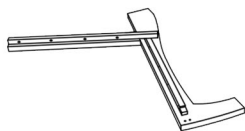

Right leg

Bx1

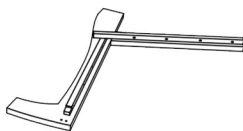

Left leg

Cx1

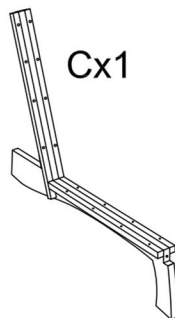

Middle leg

Dx2

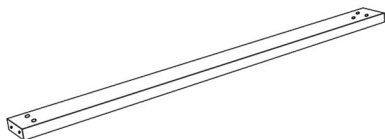

Front rail

Ex1

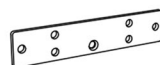

Connecting iron sheet

Fx16

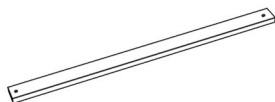

Wooden connector

Gx1

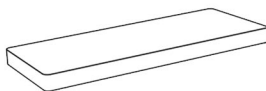

Seat cushion

Hx2



Back cushion

I*1



Seat cover
(Hide in bag)

J*2



Backrest cover
(Hide in bag)

Ox2



Bag

★The Cover with the washing label is the Backrest Cover

HARDWARE

TOOL LIST

NOTE: Designated with (★) We provide additional spare parts in the hardware package

①*7



★ M6*16mm
Bolts

②*32



★ M6*30mm
Bolts

③*4



M6*45mm
Bolts

④*1

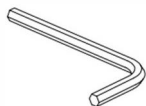

Allen key

⑤*4



Vertical nut ★ Hole cover

⑥*20



⑦*36



★ Ø6*14mm
Flat washer

Please make sure all hardware & packing material fitting the list. Especially some small accessories may be missing during transportation. Please contact us if you have any question.

step 1 ---Cut the air compression bags

After taking out the cushions (G) from the air compression bags, please allow them to recover for a period of time. It may take up to **48** hours to fully recover. You can gently slap them to speed up the process.

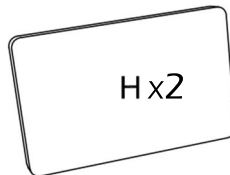
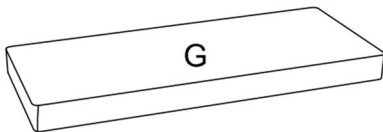
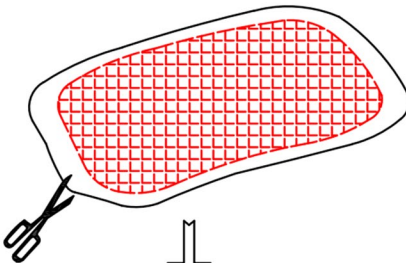
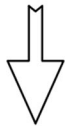
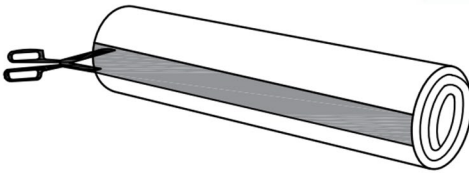
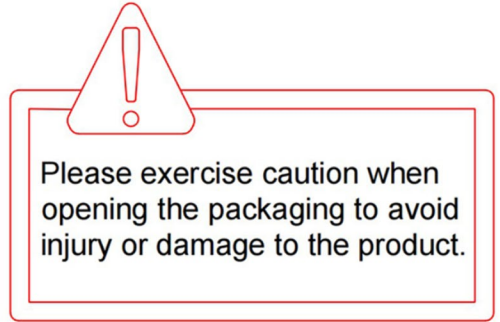

step 2 ---Take out the cushion cover

Open the bag, take out the seat cushion cover (I) and back cushion cover (J).

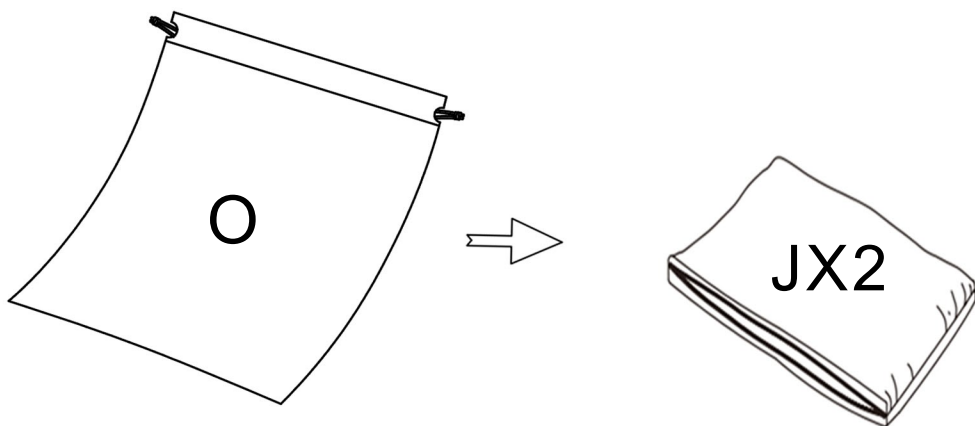
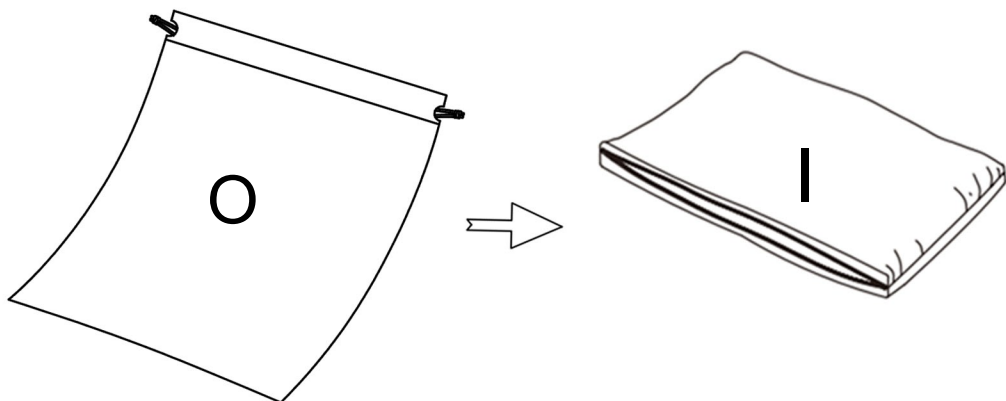

step 3 ---Put on the cushion cover

How to Put on the Cushion Cover

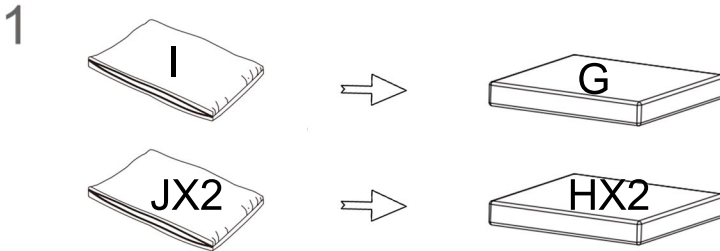

1.Take the cushion covers and inner inserts out of the carton.

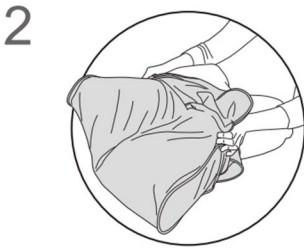

2.Fold the inner in half, pushing the sides together,then begin to slide the cover onto it.

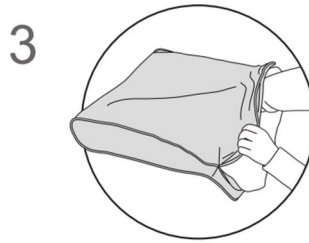

3.Align both far corners, then gently compress insert while fitting cover around it.

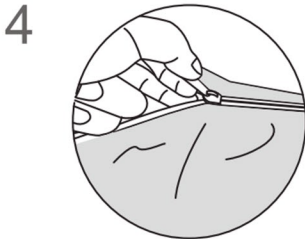

4.To avoid a stuck zipper, please pull the fabric away from the zipper before moving forward.

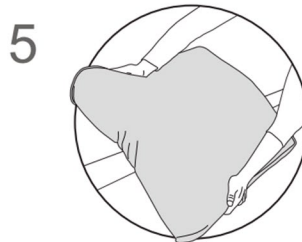

5.When all done, please pat the cushion or give it a little shake to make it more flat.

step 4 ---Fix the Iron Plate (E)

Secure the iron plate (E) to the Middle Leg (C). Use the provided allen wrench (4) to tighten the bolt. (1)

The side of the iron plate with the threaded holes is facing outward.

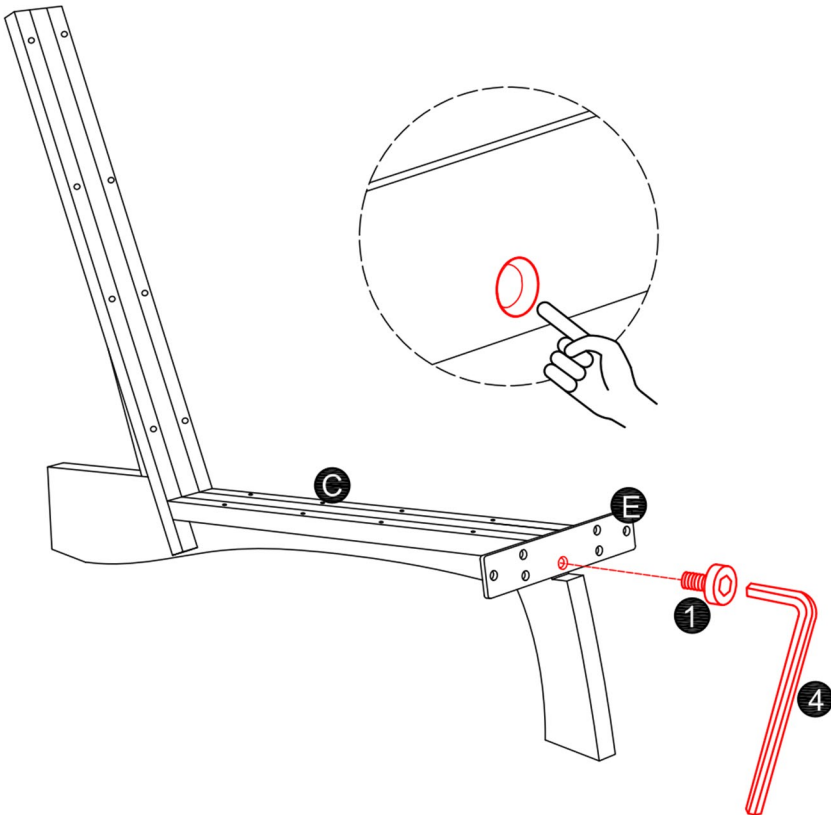

step 5 ---Connect the Front Bars (D)

Align the Front Bars (D) with the iron plate installed in the previous step. Use the provided allen wrench (4) to tighten the bolts (1) on both sides of the Iron Plate to **80%** as shown.



Notice:

We suggest tightening the bolts for 30-50% first, make sure the process is correct and bolt holes are aligned, then fully tightening them all.

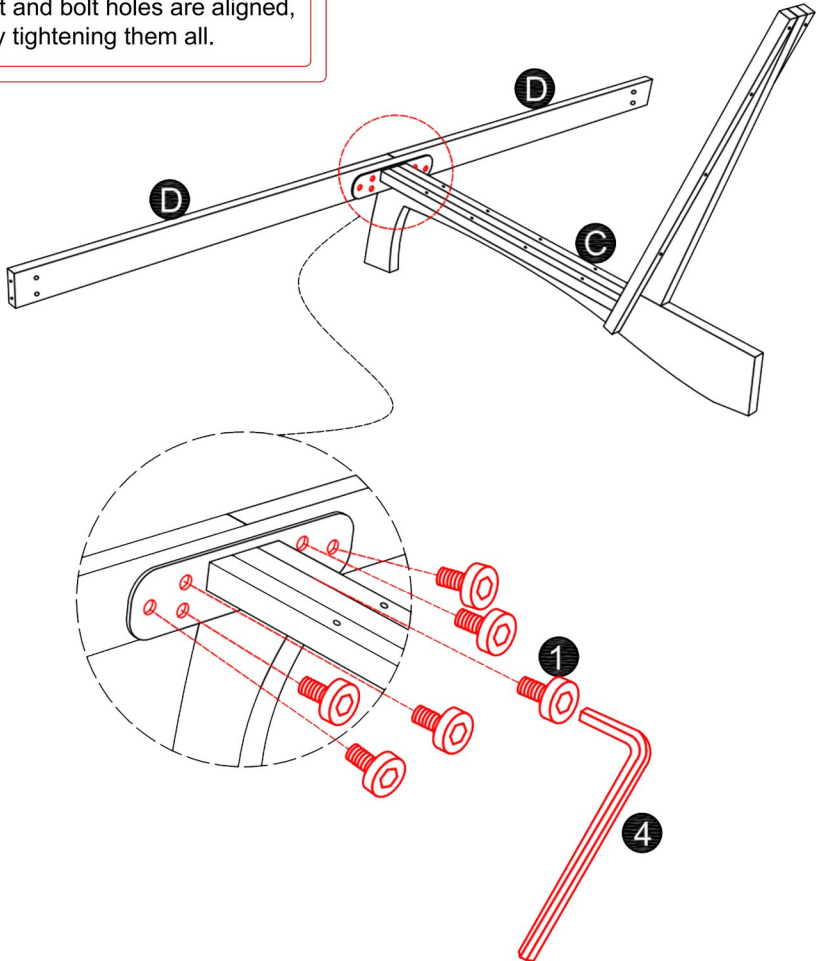

step 6 ---Install the Wood Frame Bars (F)

Align the Wood Frame Bars (F) with the designated holes on both the Left and Right Legs, as shown. Place one washer on each bolt, then use the provided allen wrench (4) to tighten all bolts (2) to **80%**.

! First add one flat washer on each bolt as shown, use the allen wrench provided to tighten all the bolts by 30-50% first, make sure that all bolts are aligned correctly before fully tightening.

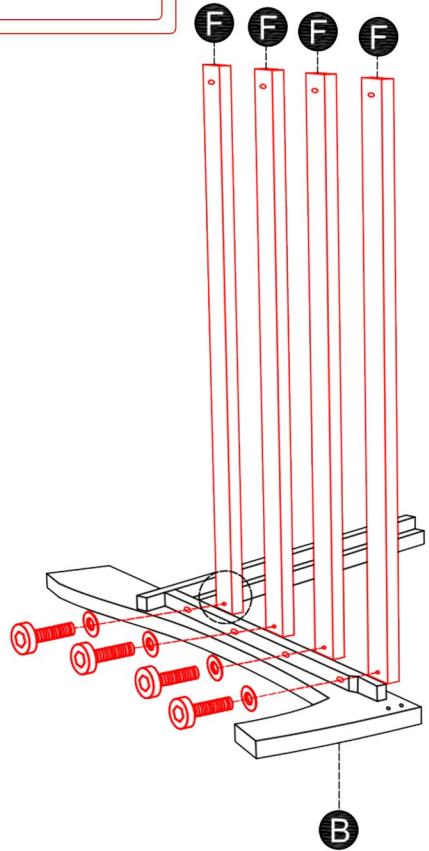
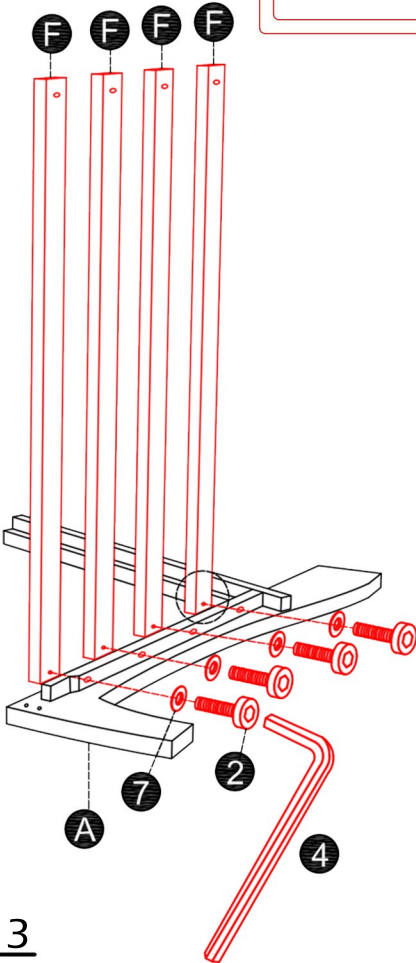

step 7 ---Place the Vertical Nuts (5)

Insert the Vertical Nuts (5) into the pre-drilled holes on the Front Bars (D). Ensure the holes on the side of the Vertical Nuts align with the holes on the sides of the Front Bars.

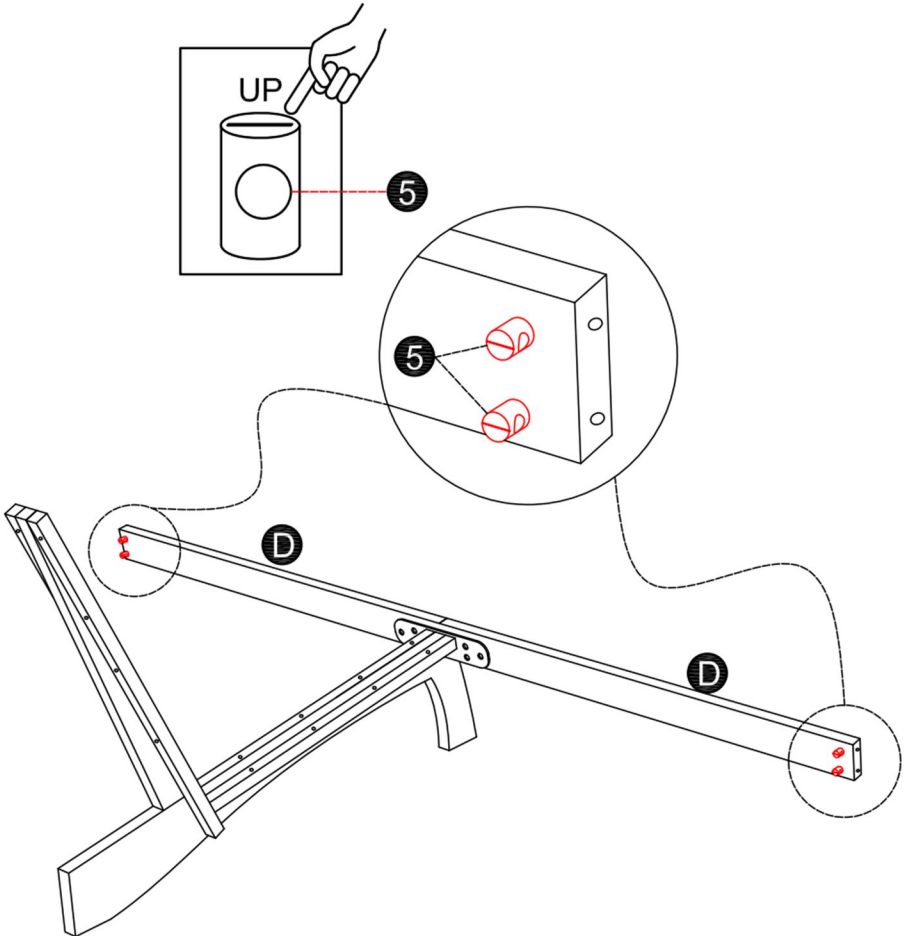

step 8 ---Connect the Left and Right Legs (A&B)

Place one flat washer (7) on each bolt (3). Then, use the provided allen wrench (4) to secure the Left and Right Legs to the Front Bars as shown. Tighten all bolts (3) to **80%**.

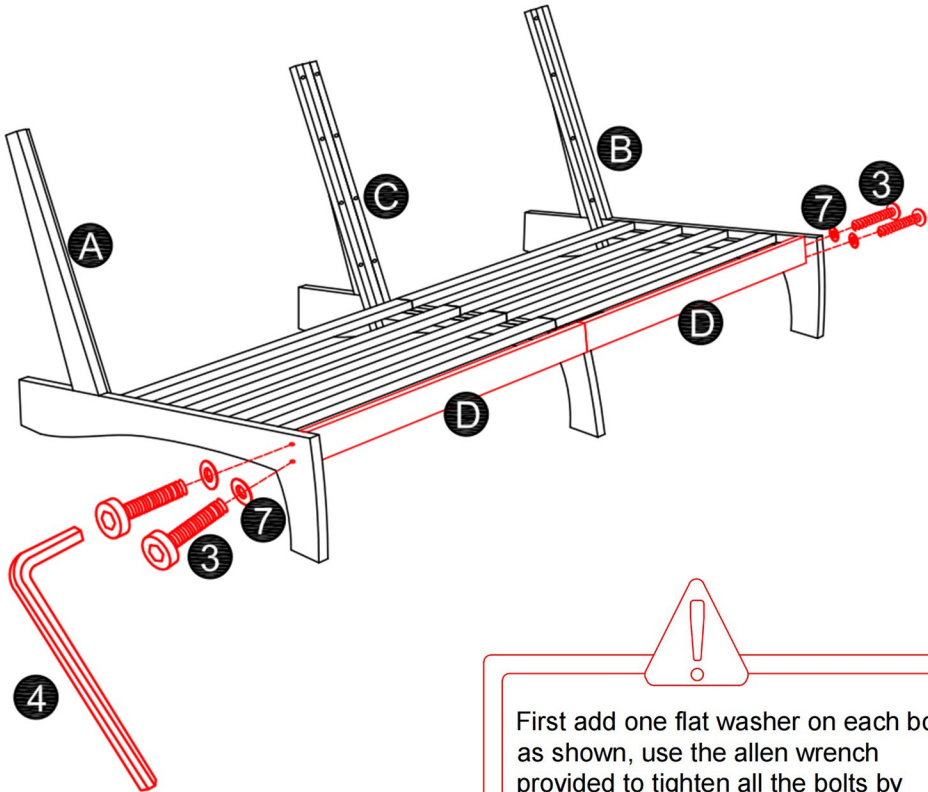

First add one flat washer on each bolt as shown, use the allen wrench provided to tighten all the bolts by 30-50% first, make sure that all bolts are aligned correctly before fully tightening.

step 9 --- Secure the Middle Legnd the Middle Leg to 80%.

Flip the assembled unit over as shown. Use the provided allen wrench (4) to tighten the bolts (2) and washers (7) connecting the Wood Frame Bars and the Middle Leg to 80%.

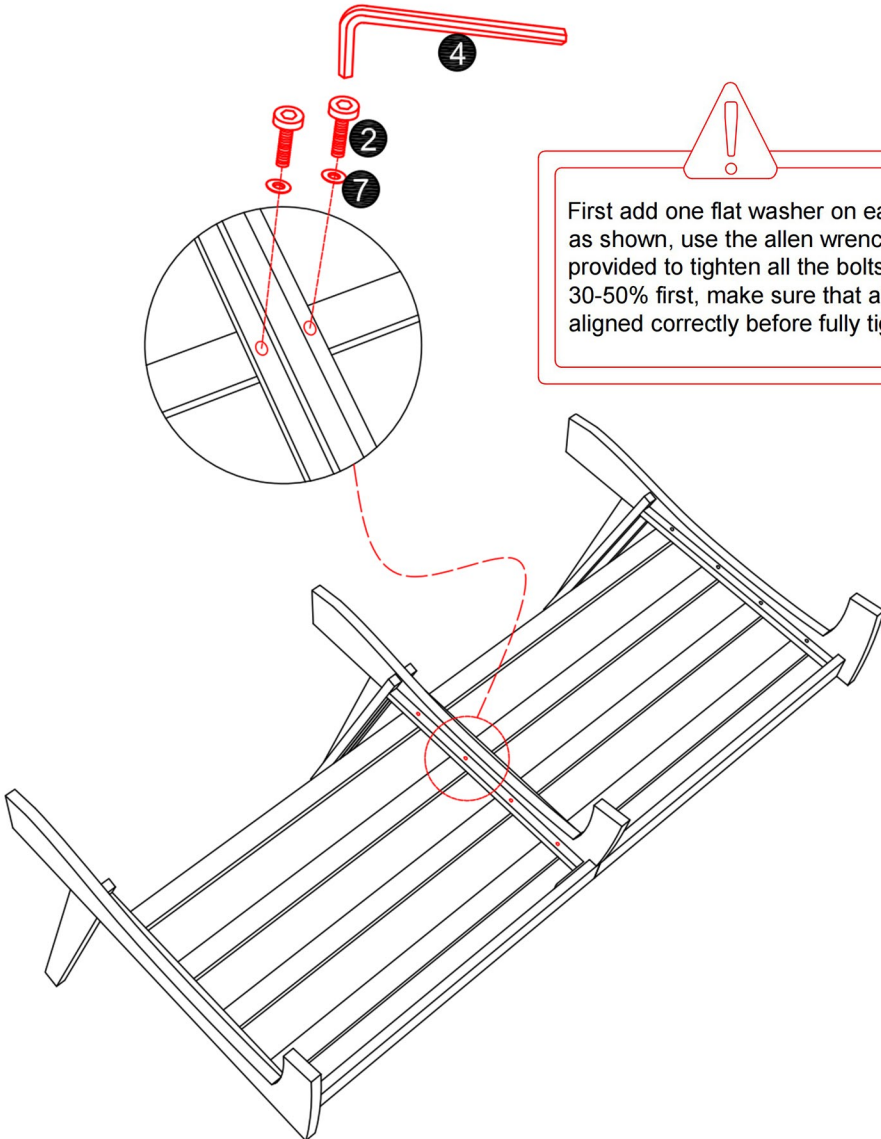

step 10 --- Install the Back Frame Bars (F)

Stand the assembled unit on its legs. Install the Wood Frame Bars (F) to the back as shown. Use the provided allen wrench (4) to fully tighten all bolts (2) and washers (7).



First add one flat washer on each bolt as shown, use the allen wrench provided to tighten all the bolts by 30-50% first, make sure that all bolts are aligned correctly before fully tightening.

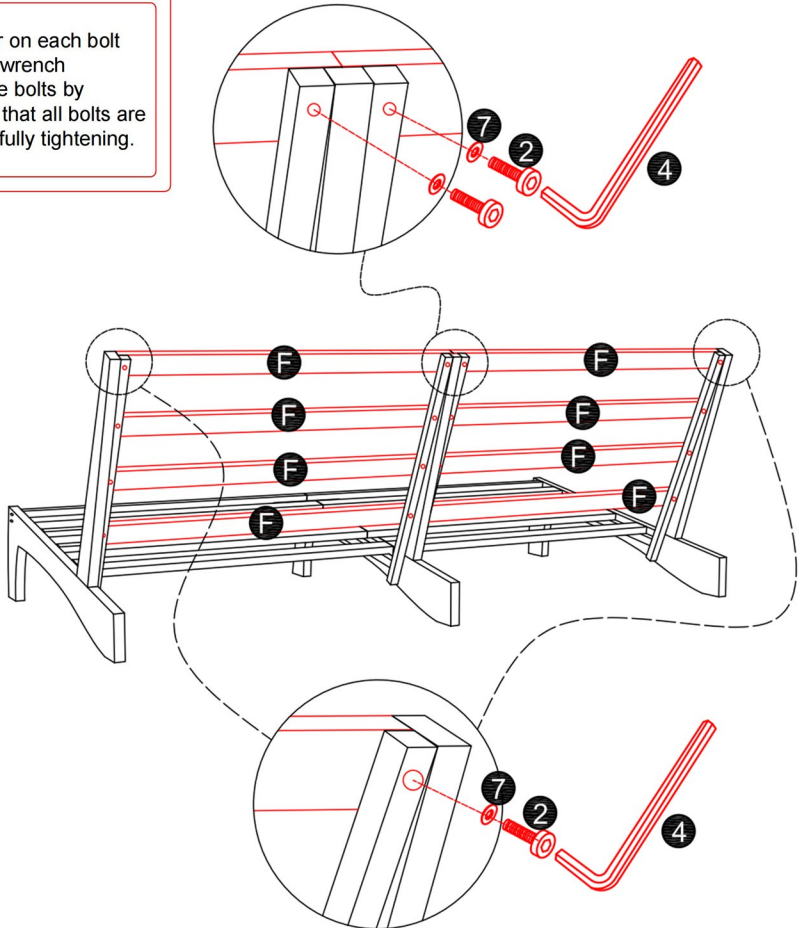

step 11 --- Install the Plastic Caps (6)

Place the Plastic Caps (6) to cover all bolt holes, as shown.

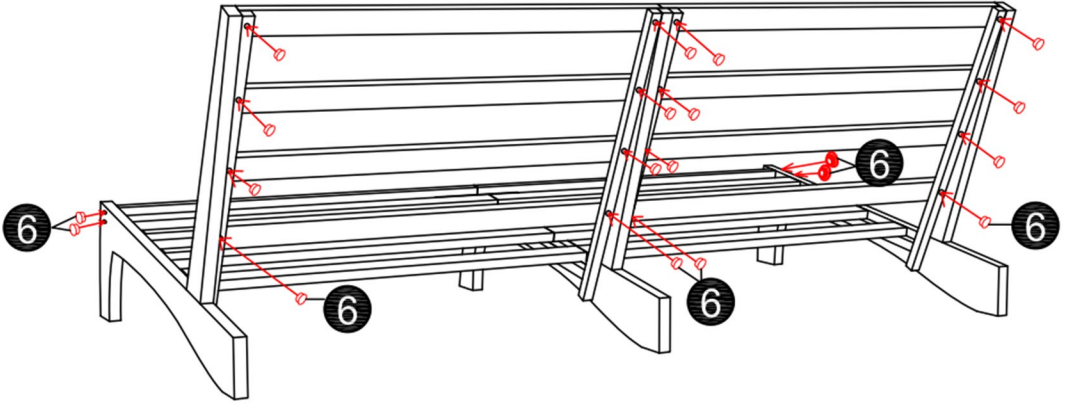

step 12 ---Place the Seat Cushion (G)

Place the Seat Cushion (G) on the chair.

Turn the Seat cushion with the labeled side facing up.

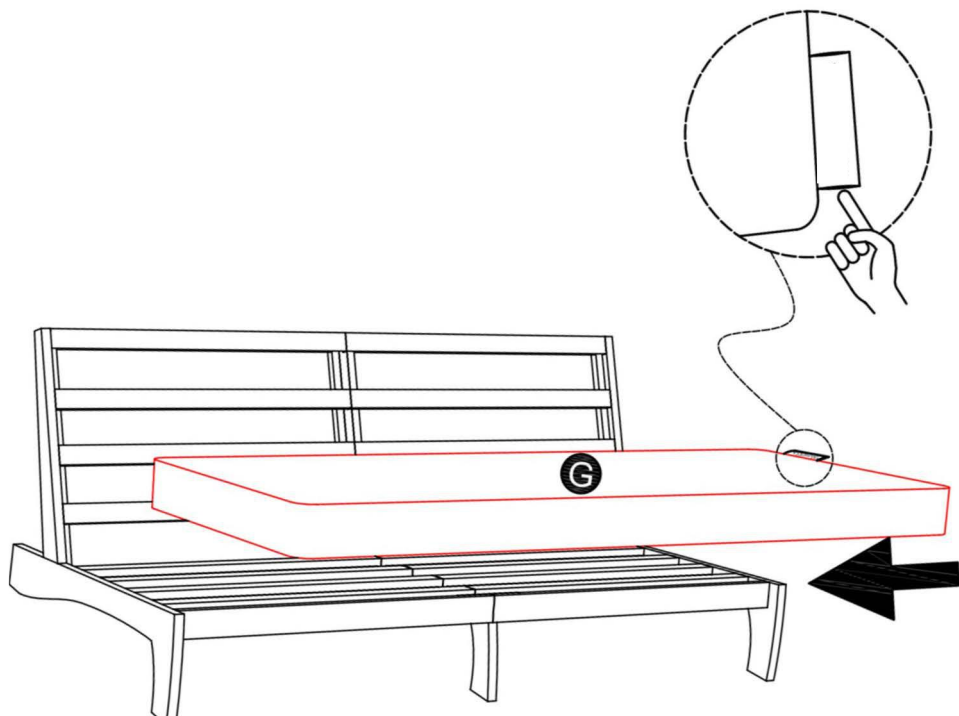

step 13 ---Place the Back Cushion (H)

Place the Back Cushion (H) on the chair.

Turn the Seat cushion with the labeled side facing up.

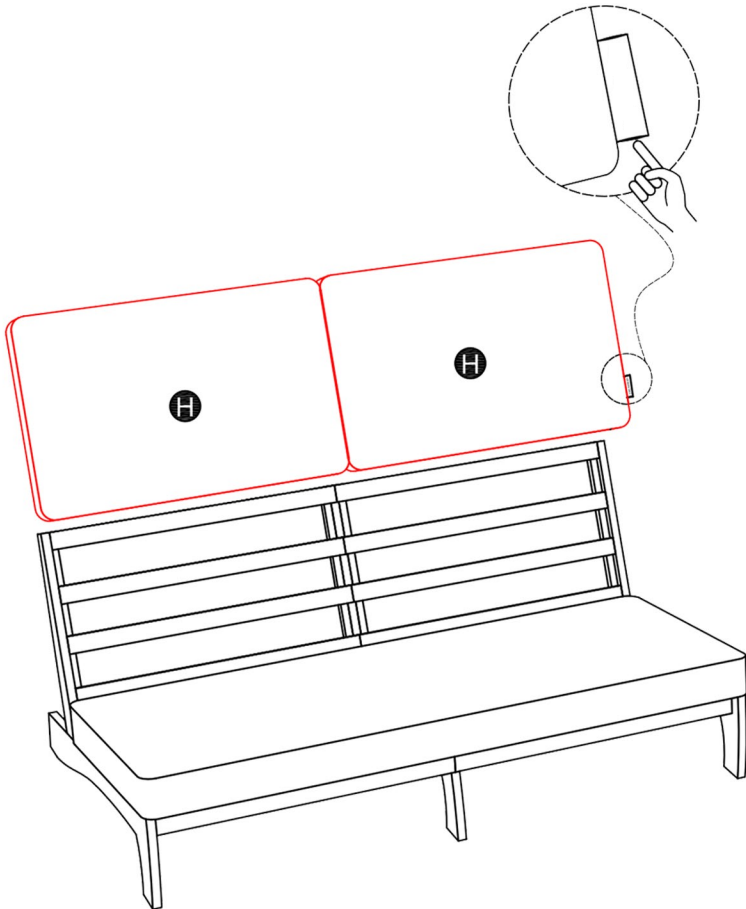

step 14 ---Assemble complete

Congradulations! You have finished the assembly, thank you again for choosing our product! Please enjoy!

