

Dear Customer

Thank you for your order. We hope that you have received your furniture in the pristine condition that we sent it out in.

In the unfortunate event that your order was mishandled during transit, please contact us to let us know the extent of the damages so we can resolve for you as soon as possible.









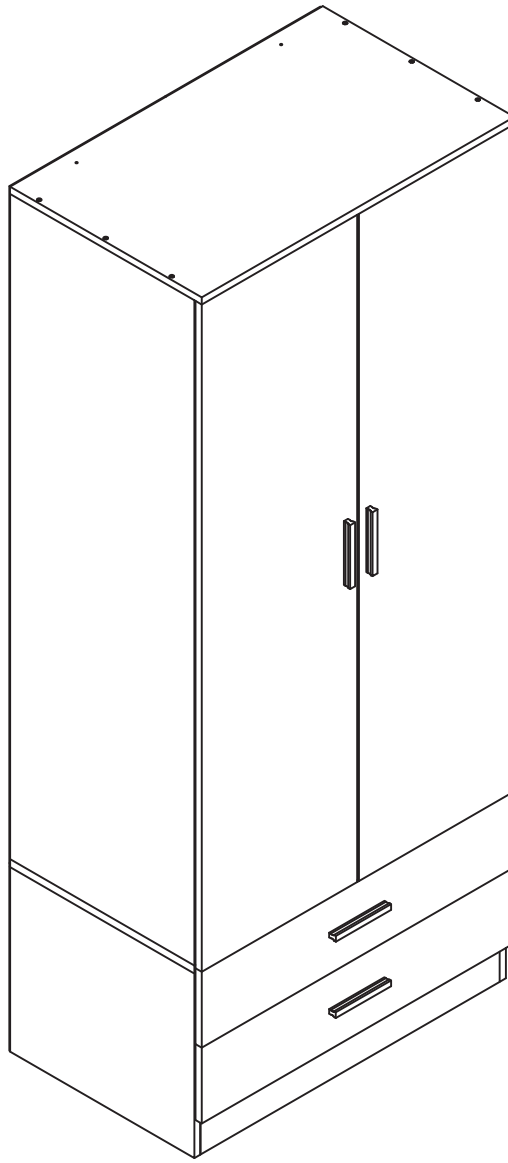

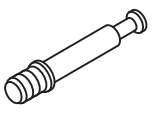



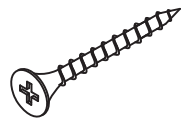

If replacement parts are required, please email us with images and the part number referenced in this manual and we will have a replacement sent out right away.

Please include the full name and postcode used to place the order in your email so we can locate your order in our systems.

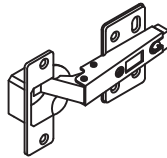
The Customer Satisfaction Team

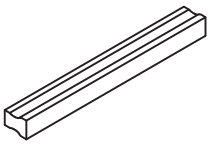
ASSEMBLY INSTRUCTIONS



													
A	24PCS	B	24PCS	C	12PCS	D	24PCS	E	4PCS	F	2PCS	G	24PCS
													
H	10PCS	I	10PCS	J	36PCS	K	6PCS	L	36PCS	M	8PCS	N	4PCS
 CL DL DR CR													
O	2PCS	P	2PCS	Q	2PCS								

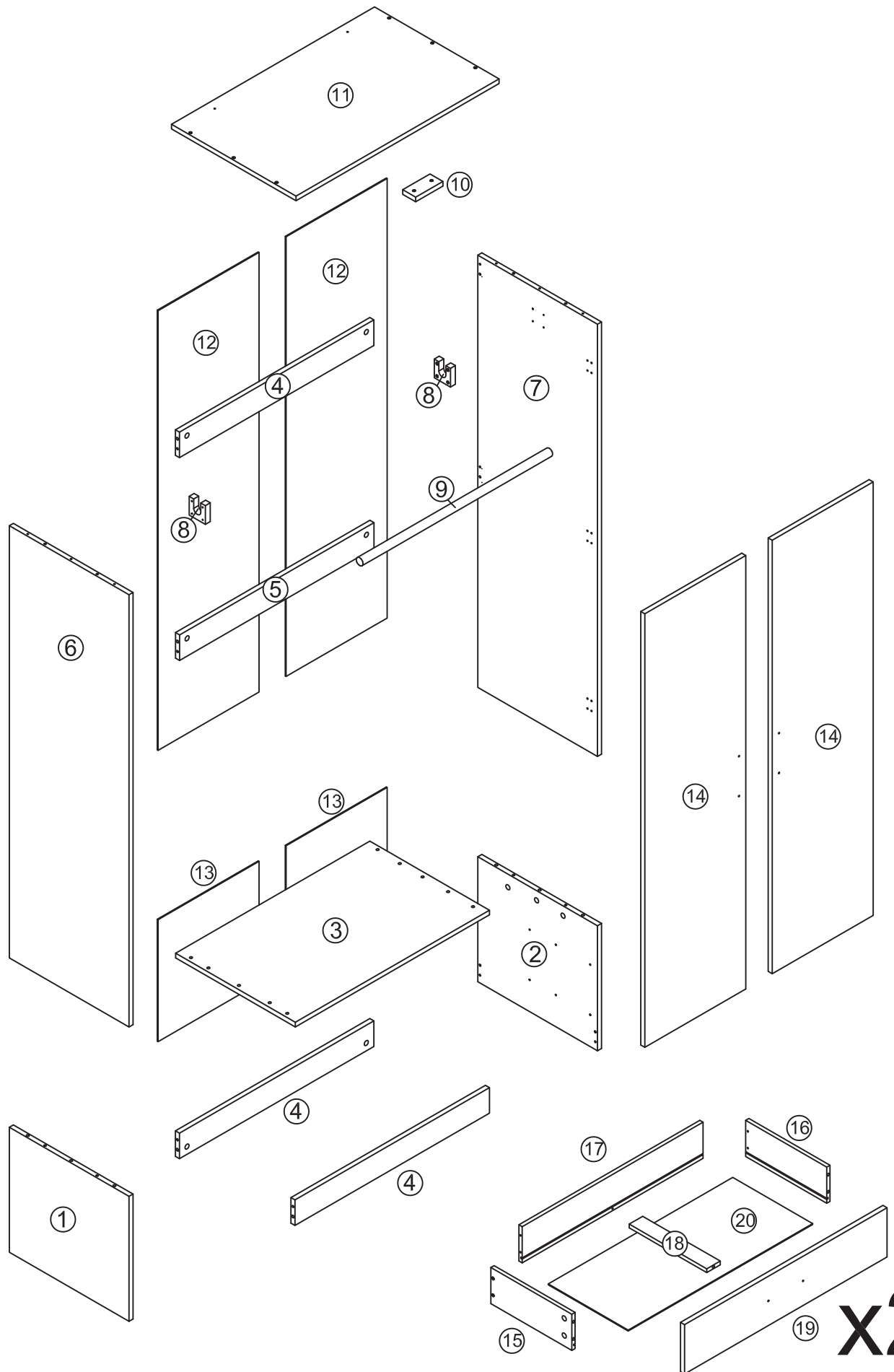

x2

1

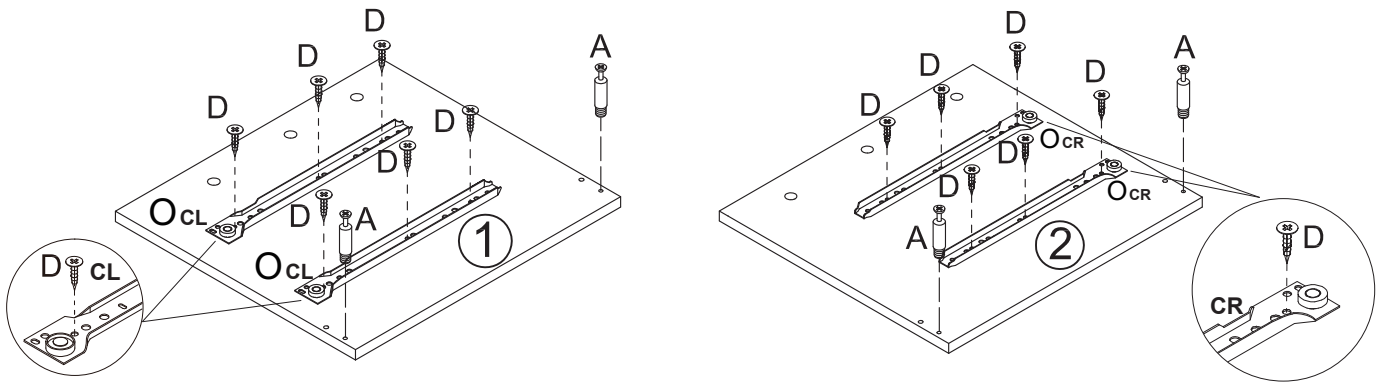

2

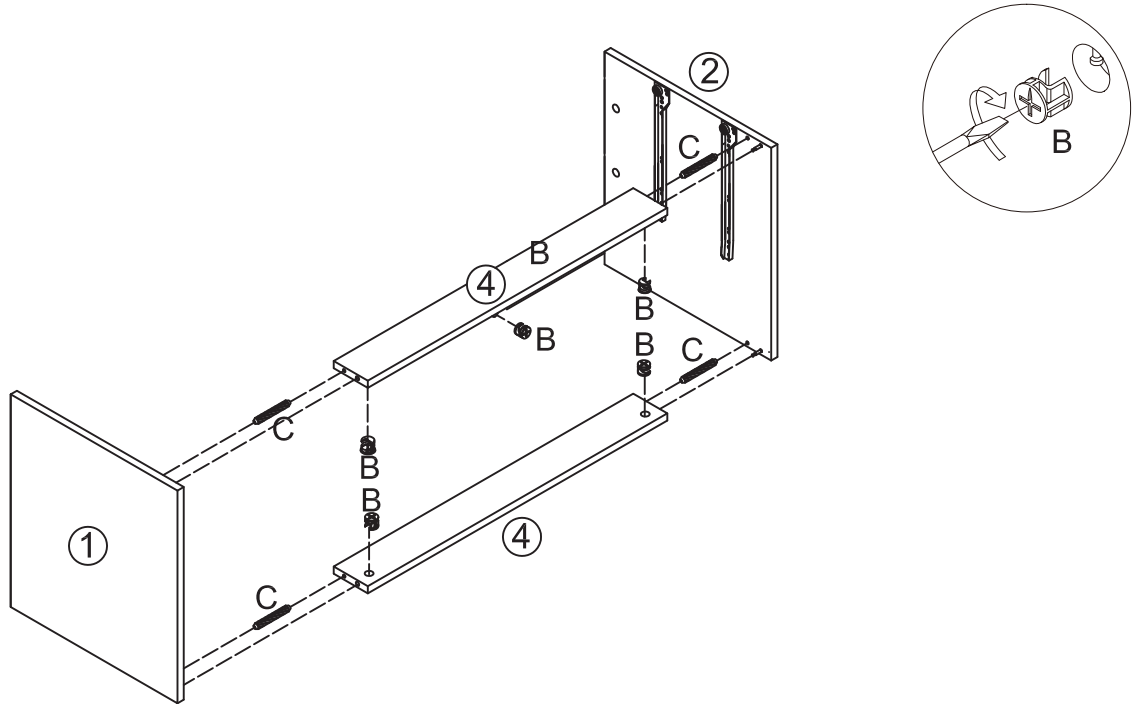

3

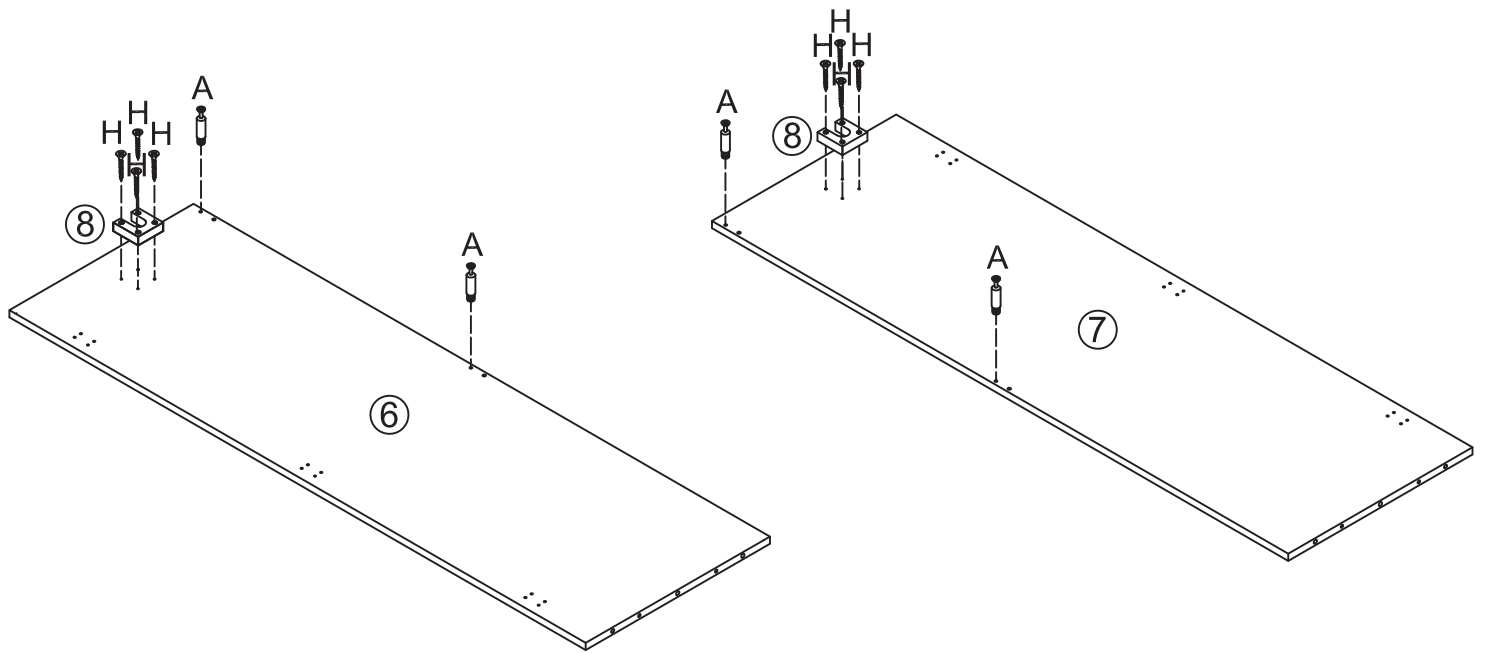

4

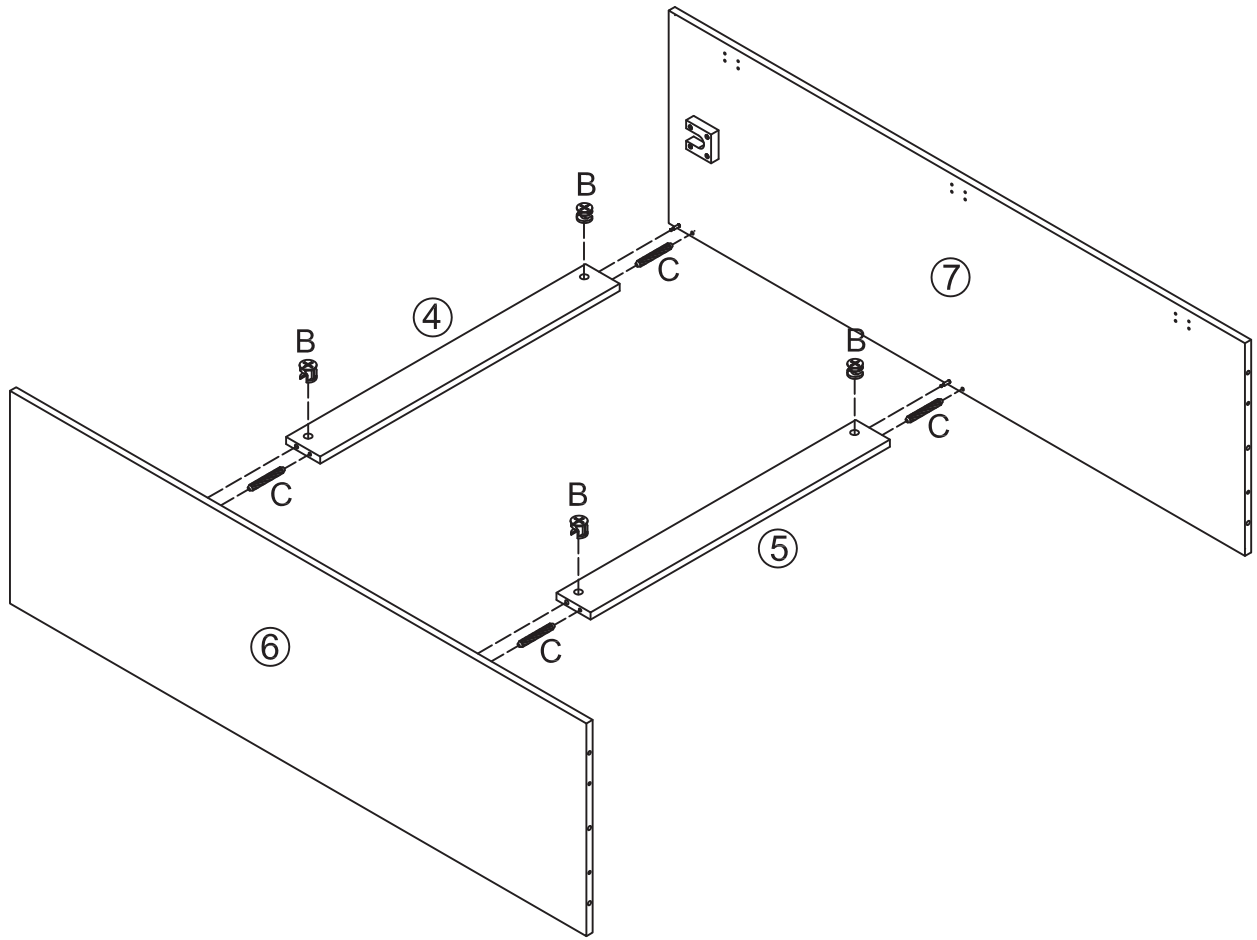

5

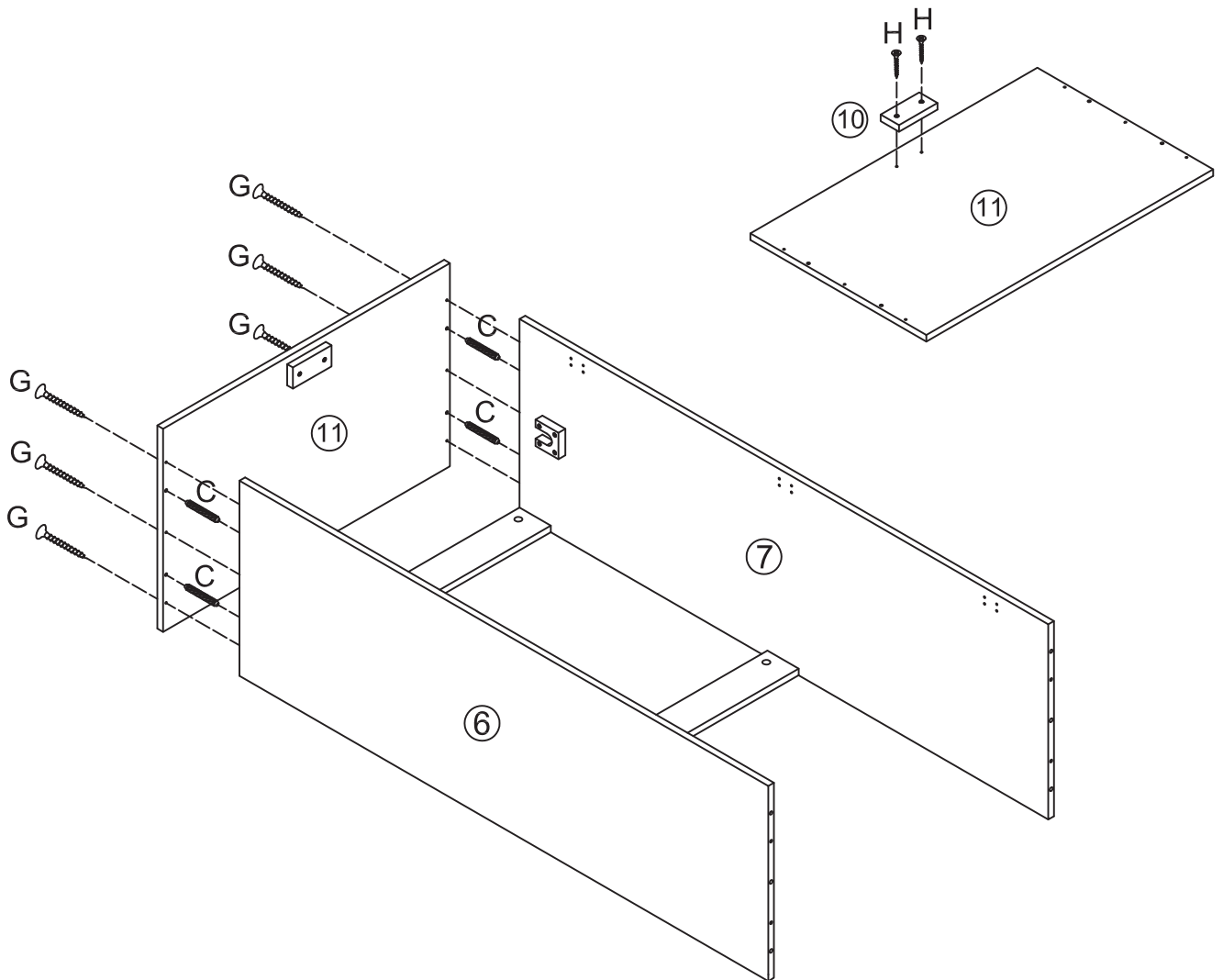

6

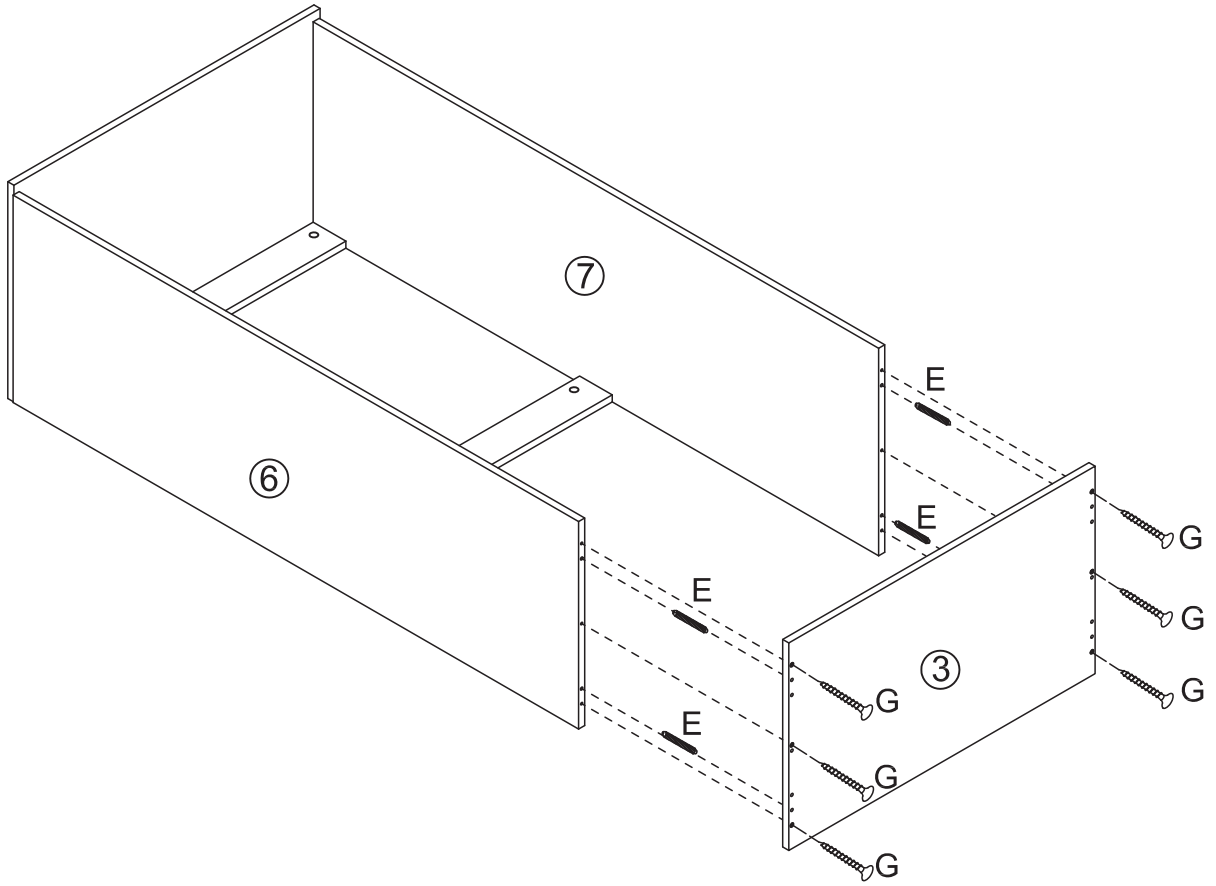

7

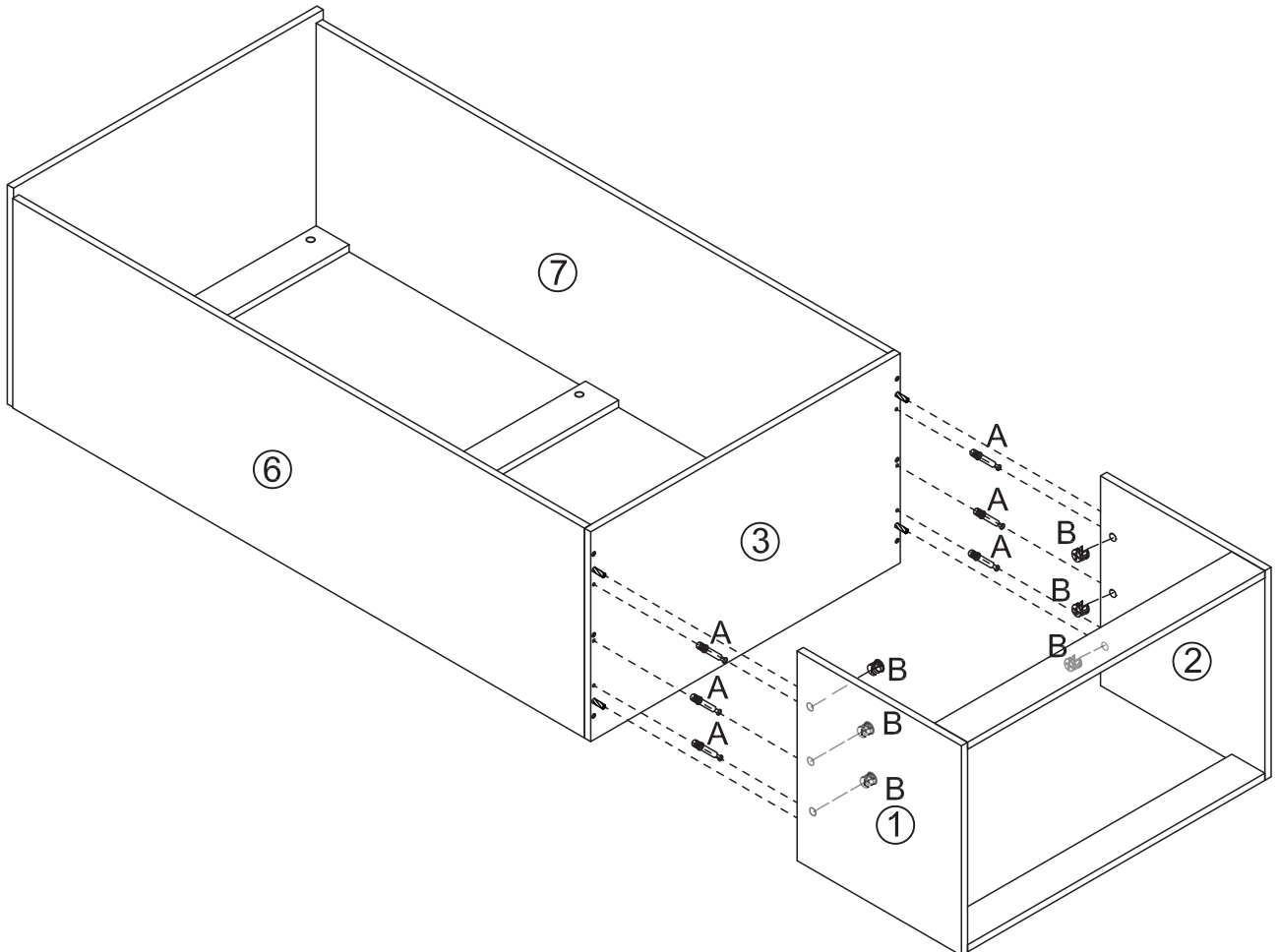

8

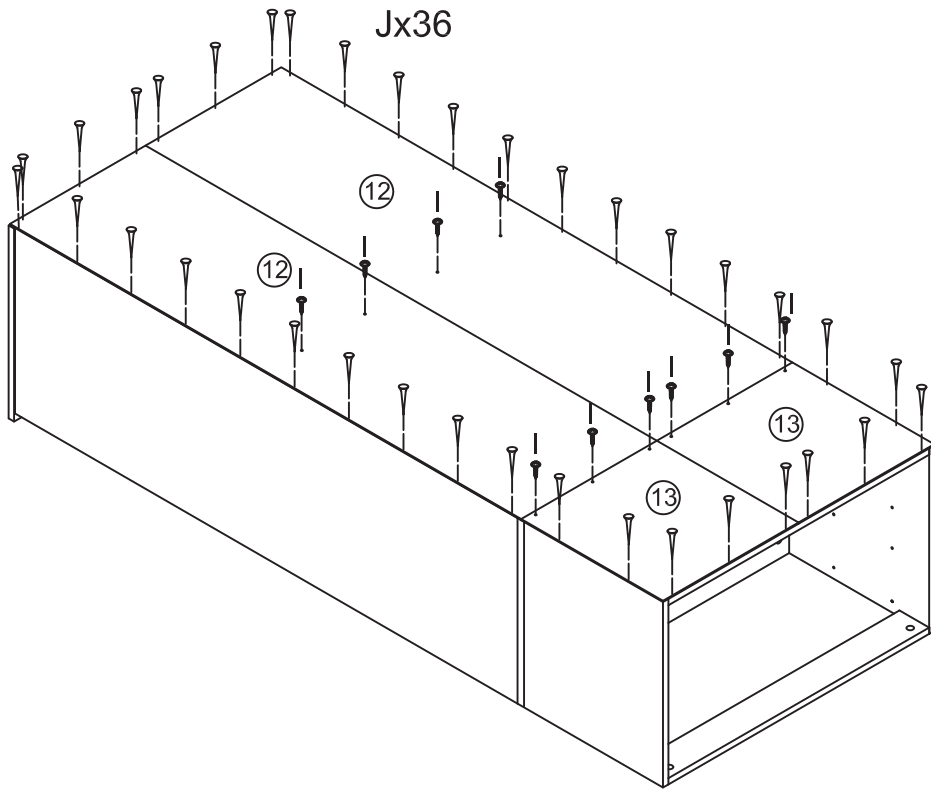

9

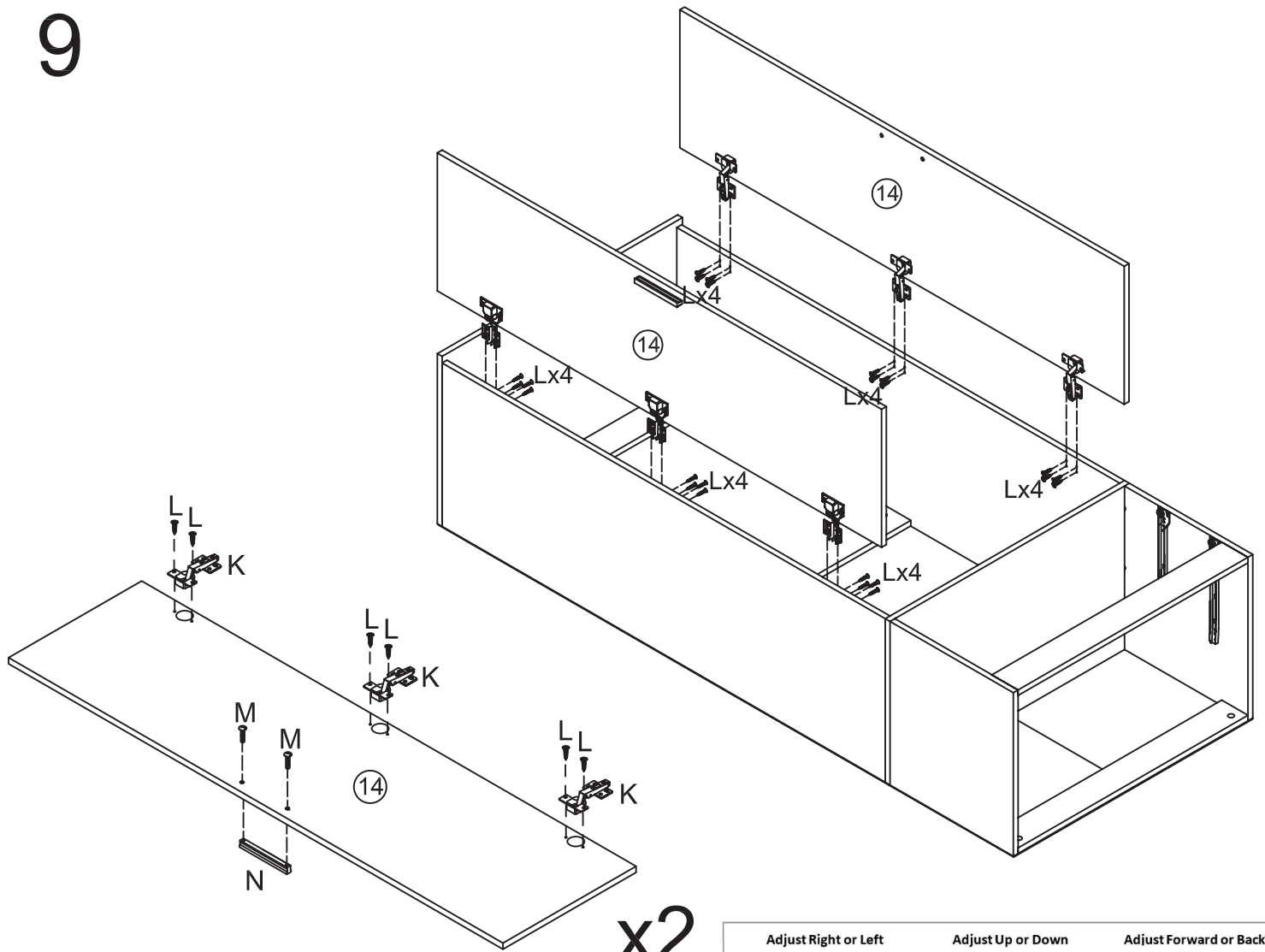

x2

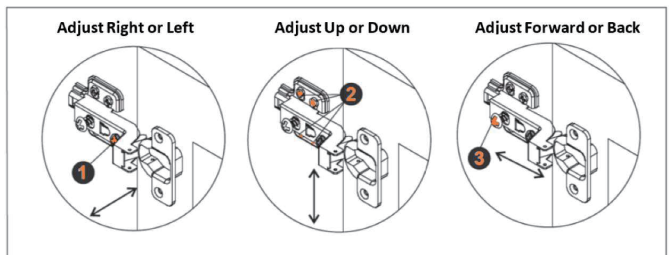

10

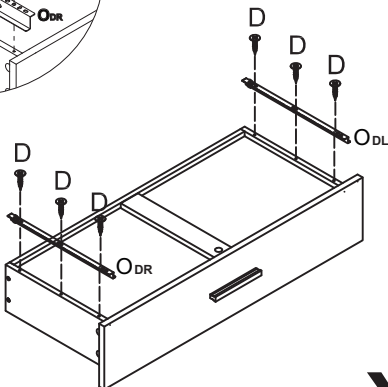
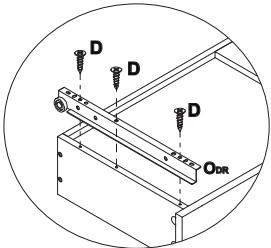
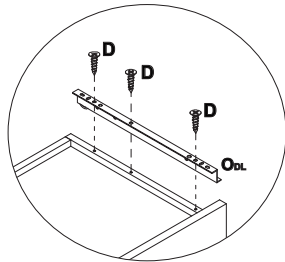
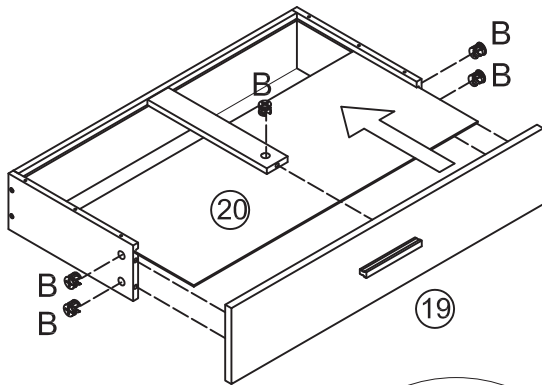
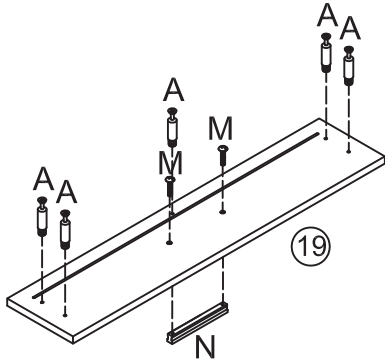
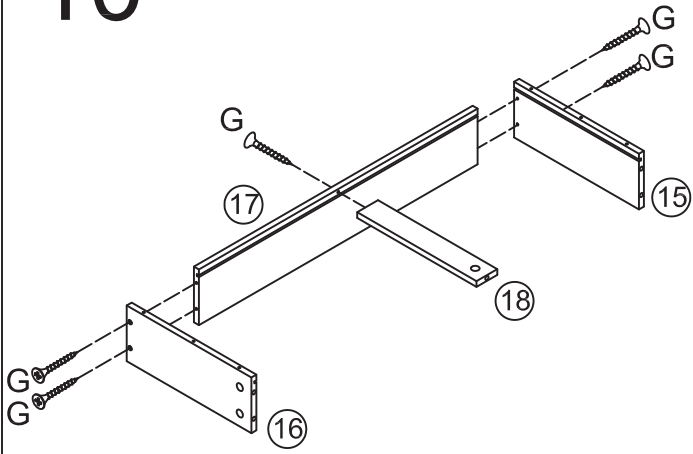

x2

11

