

# Assembly Instructions

## Low Loft Bed with End Ladder and Tent

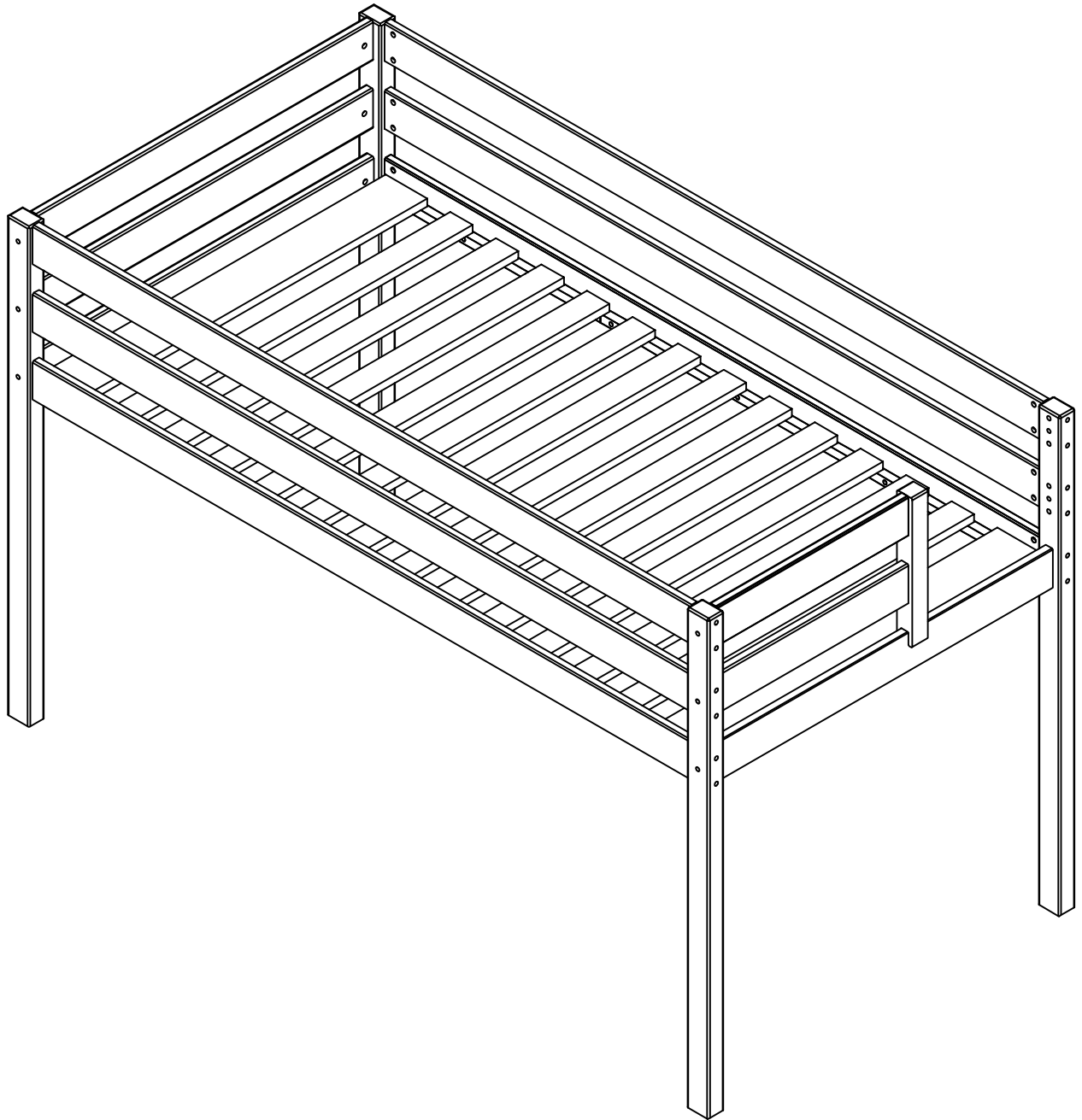

**WARNING - CHOKING HAZARD**  
**To be Assembled by Adults only!**  
**Small parts can be a choking hazard for children**

ASSEMBLY INSTRUCTION  
LOW LOFT BED  
FAIBLE LIT MEZZANINE  
CAMA ALTA BAJA

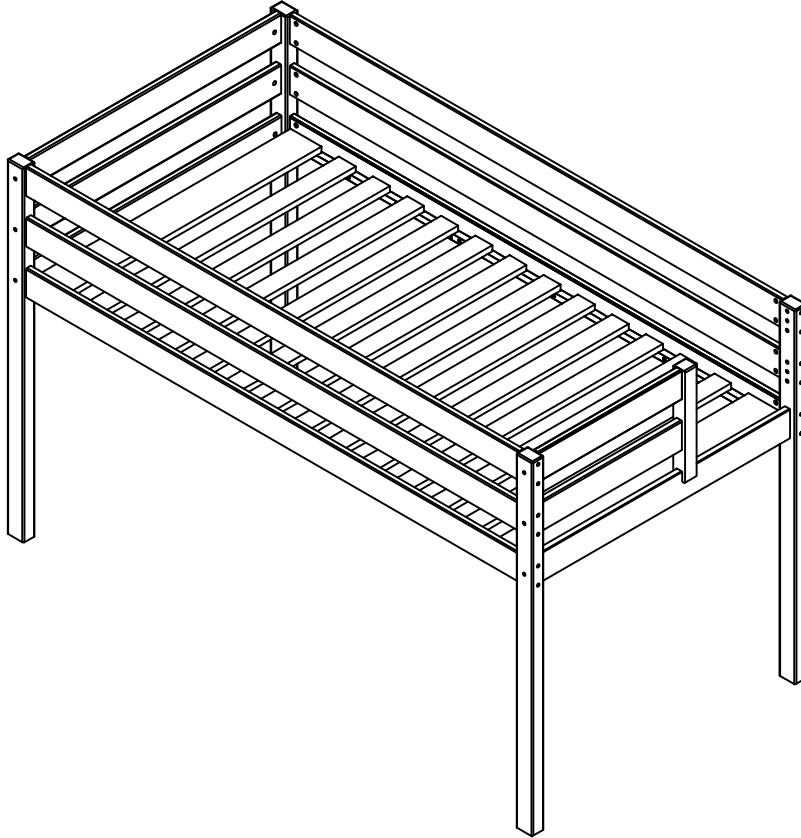



01 - 2x



02 - 2x

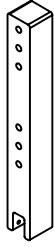

05 - 1x

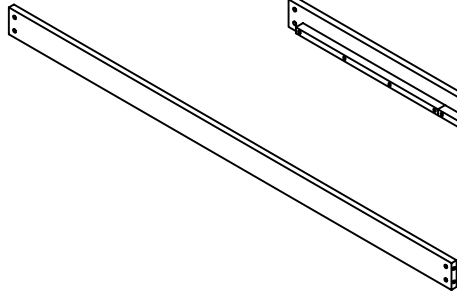

06 - 4x

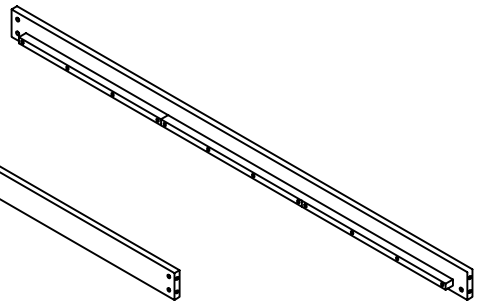

07 - 2x

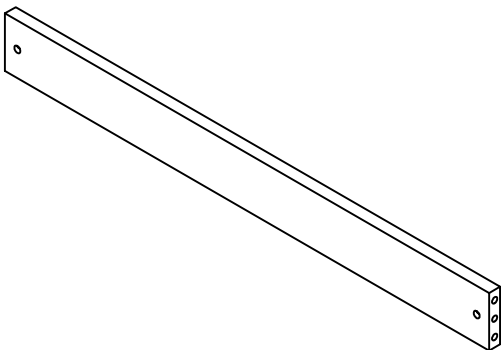

03 - 4x

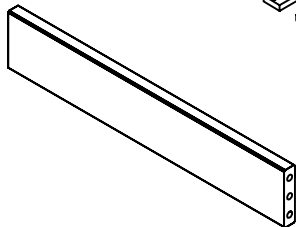

04 - 2x

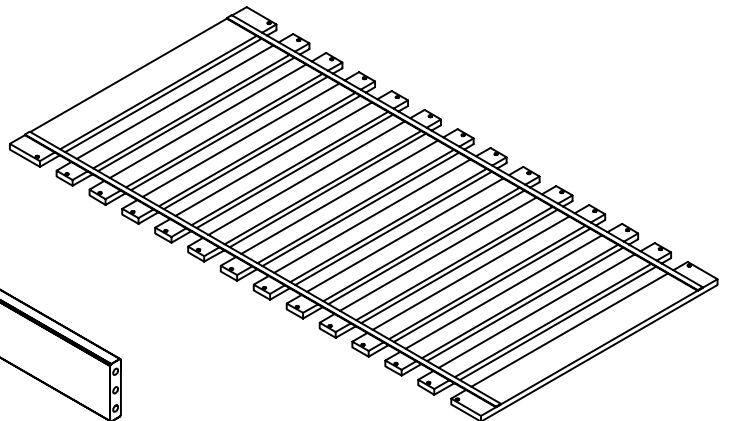

10 - 1x

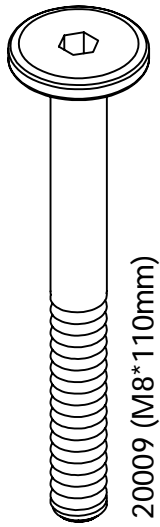

20009 (M8\*110mm)

36x

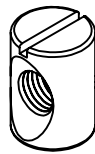

20359 (φ8\*17mm)

36x

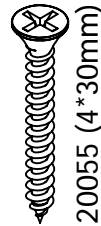

20055 (4\*30mm)

28x



20343 (4\*25mm)

3x

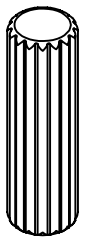

20056 (φ10 x 40mm)

24x



20033(φ10\*10mm)

12x

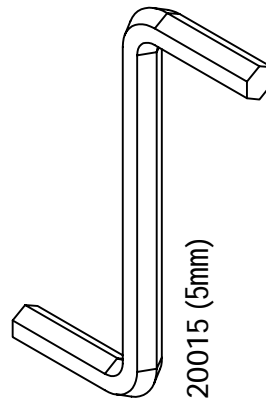

20015 (5mm)

1x





**WARNING:**

**CHOKING HAZARD--Small Parts**  
Not for children under 3 years.  
To be Assembled by an Adult

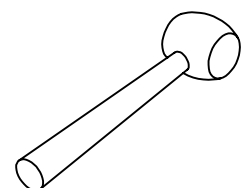

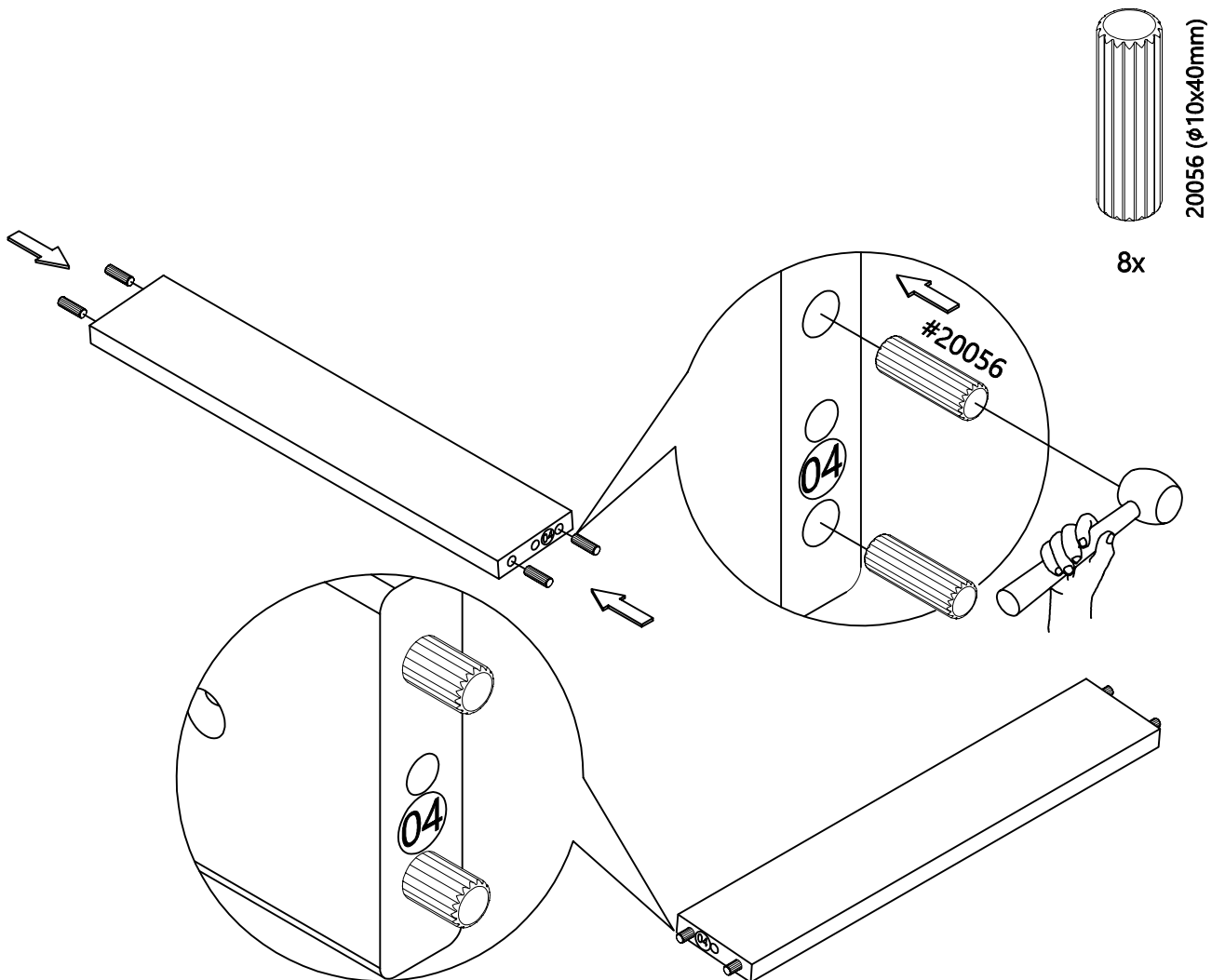
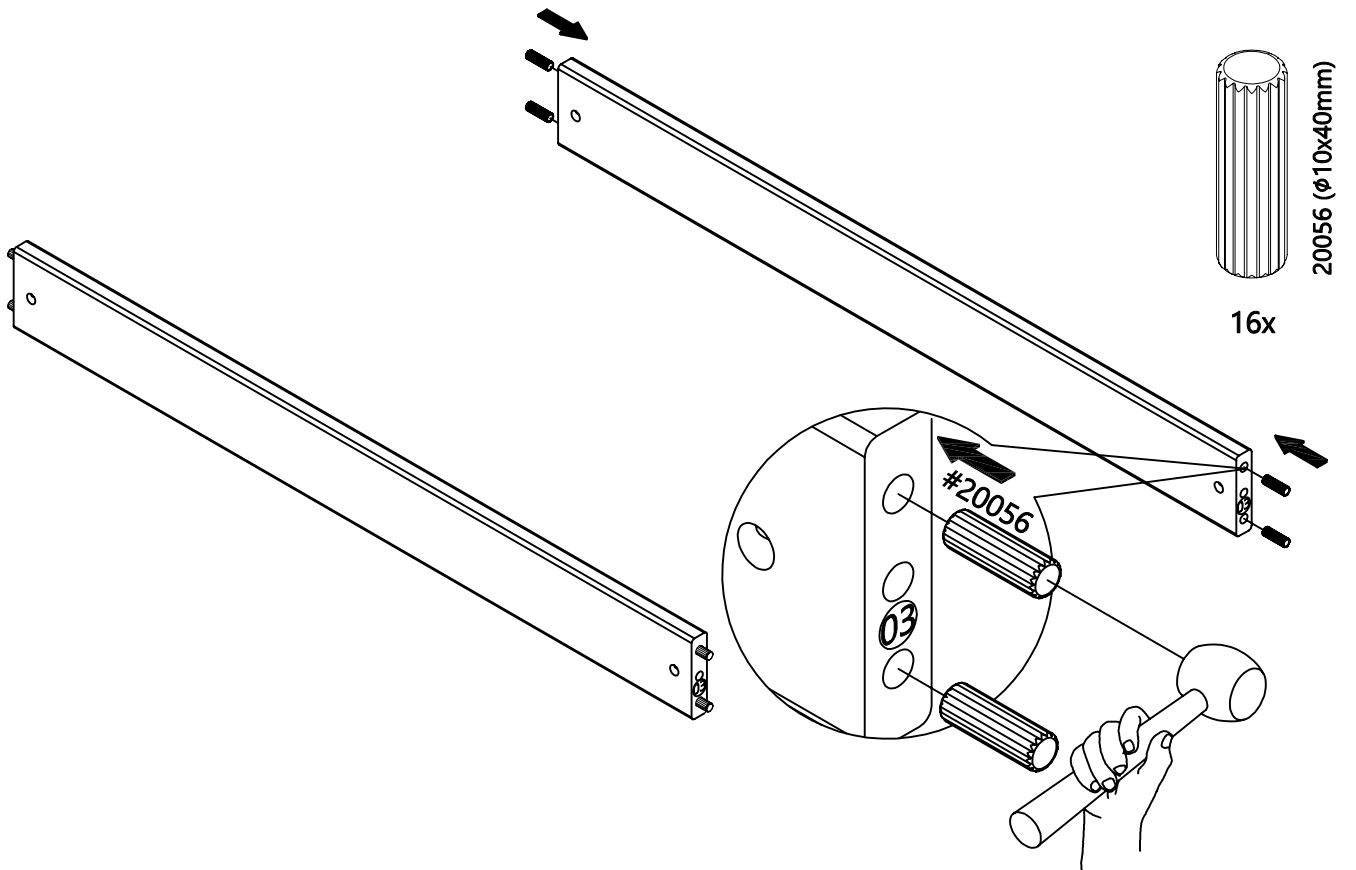
Not Include  
Non Inclus  
No Incluido



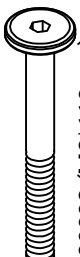

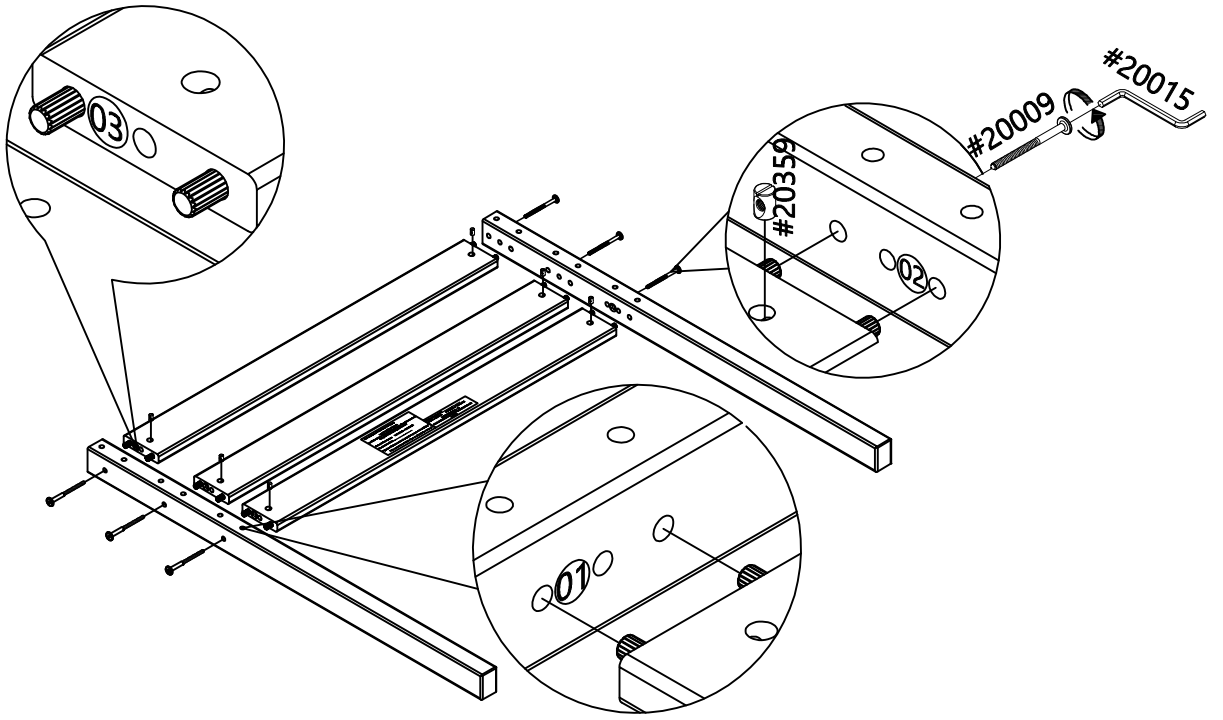
- 
 20359 (ø8\*17mm)  
 6X
- 
 20009 (M8\*110mm)  
 6X



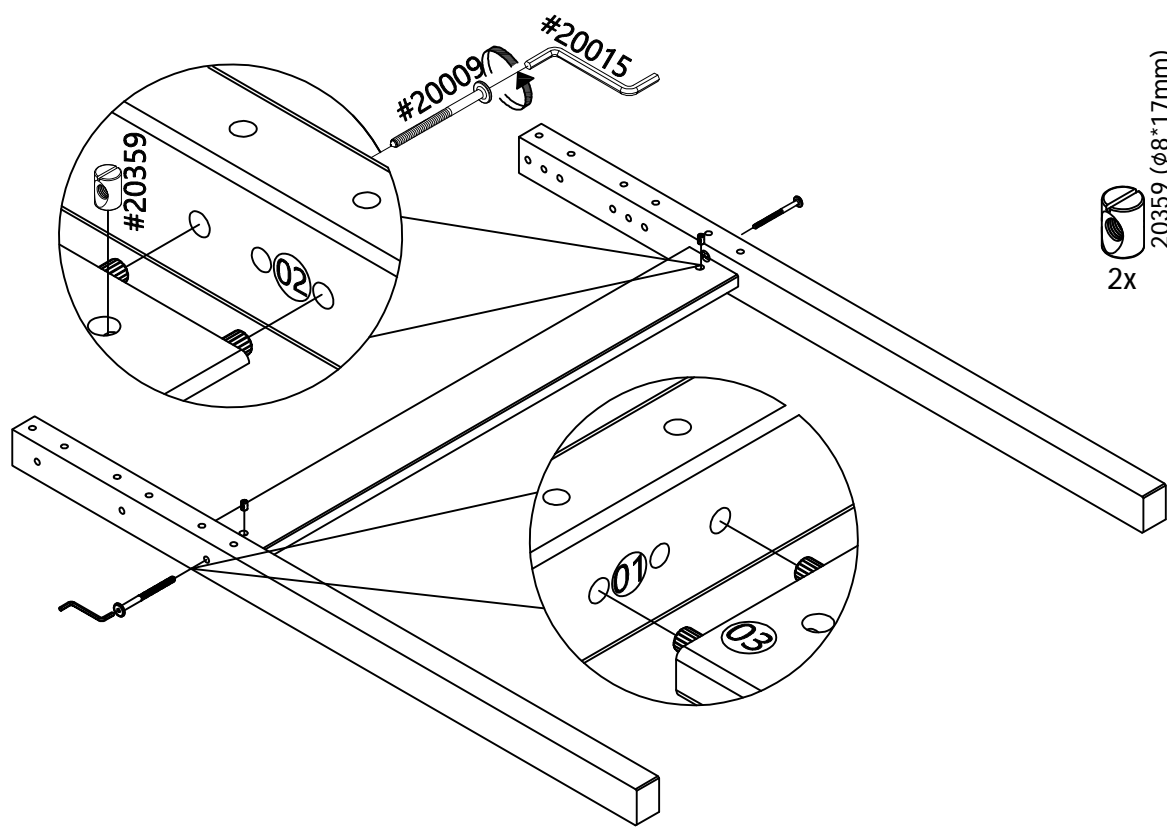

- 
 20359 (ø8\*17mm)  
 2X
- 
 20009 (M8\*110mm)  
 2X

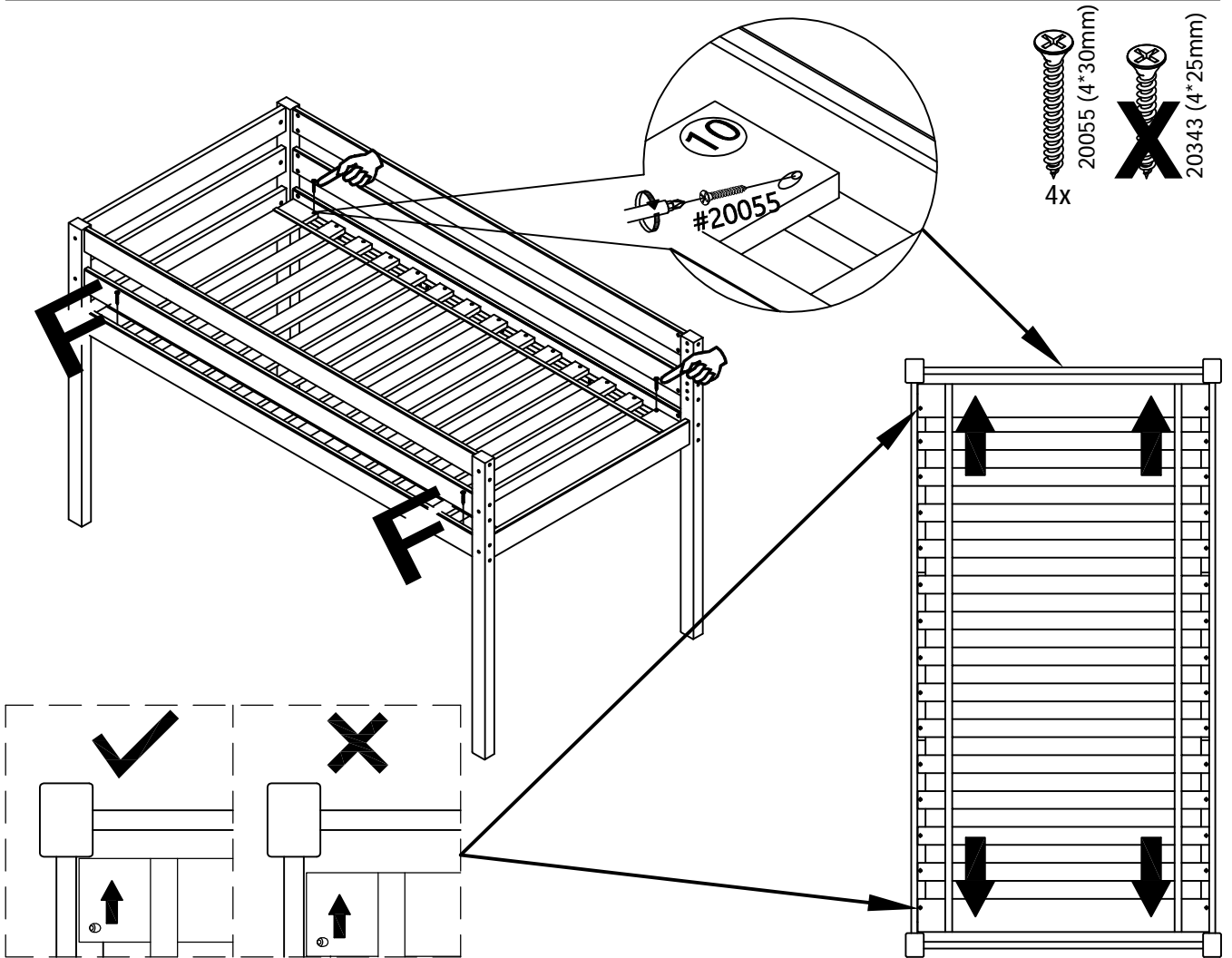
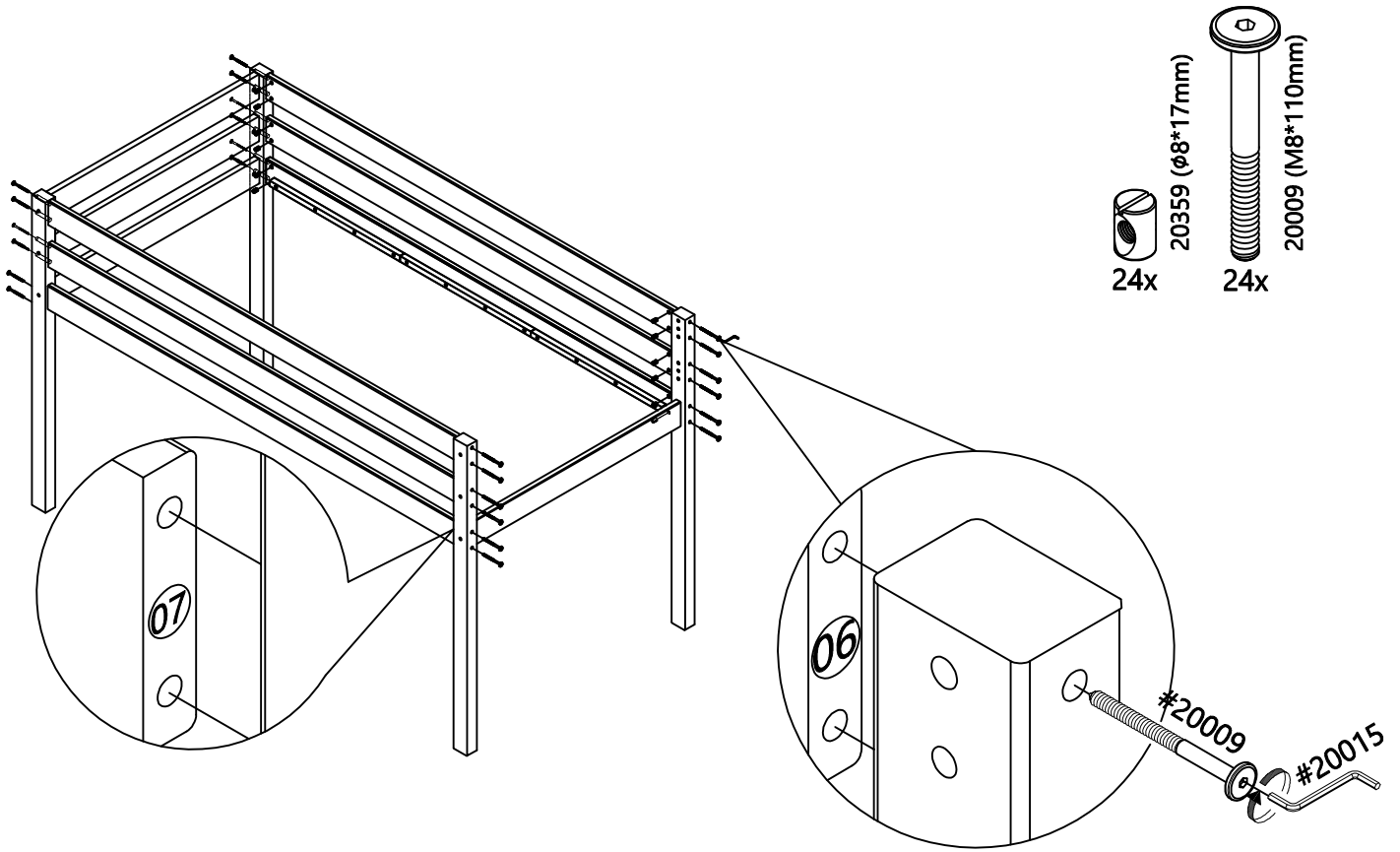

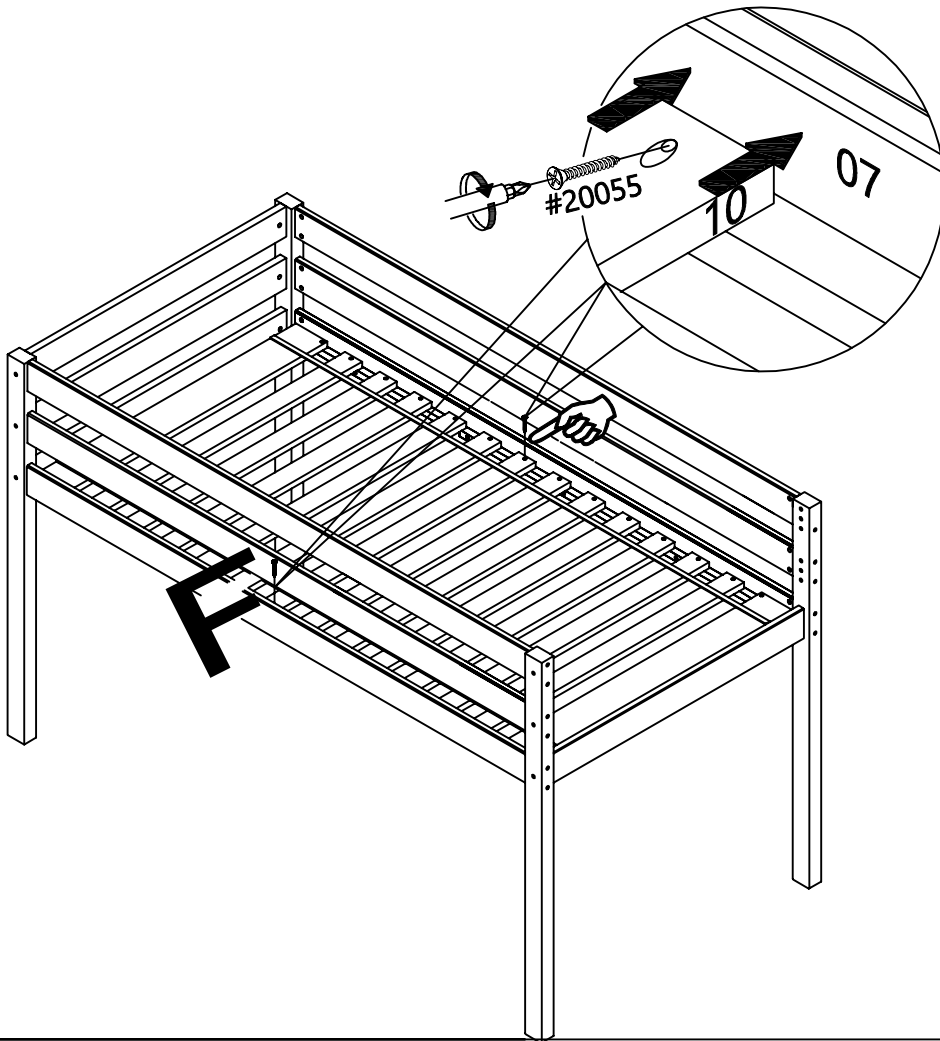



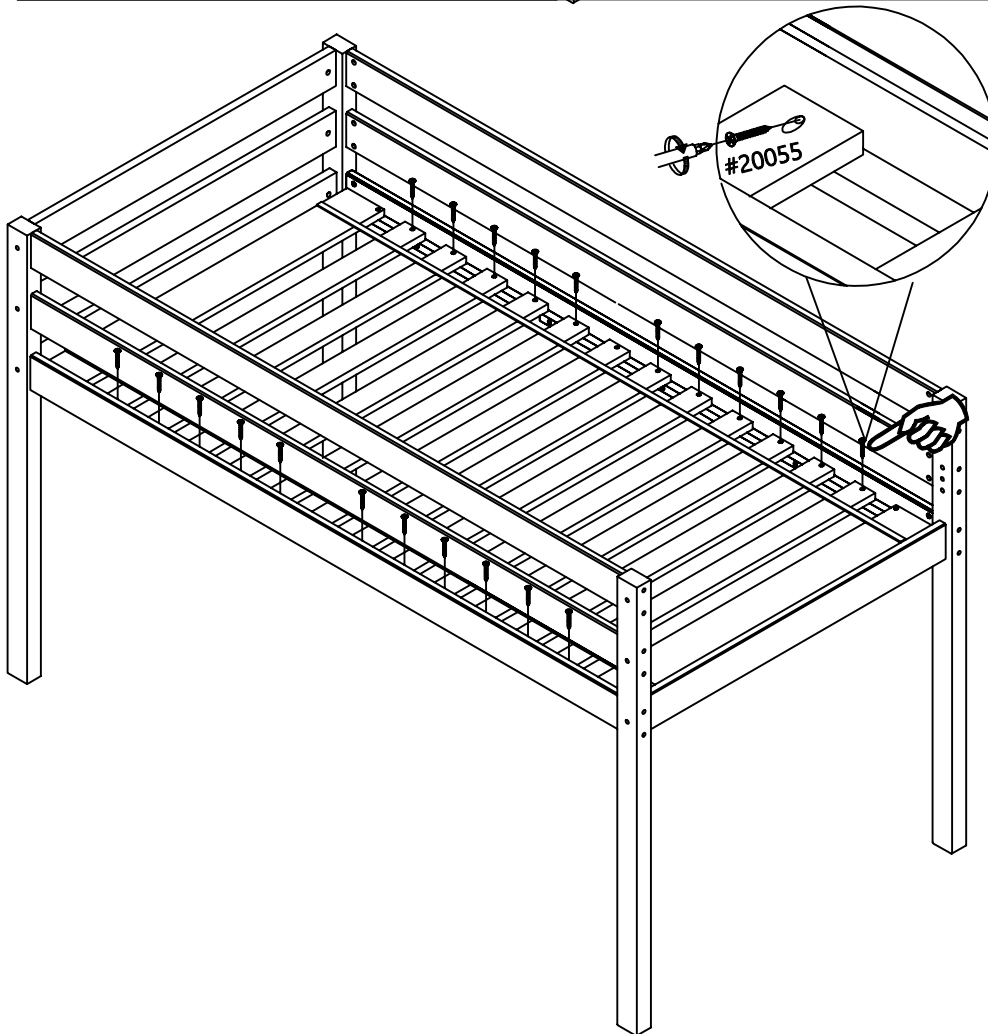

-  20055 (4\*30mm)  
2x
- ~~~~ 20343 (4\*25mm)



-  20055 (4\*30mm)  
22x
- ~~~~ 20343 (4\*25mm)

**A**

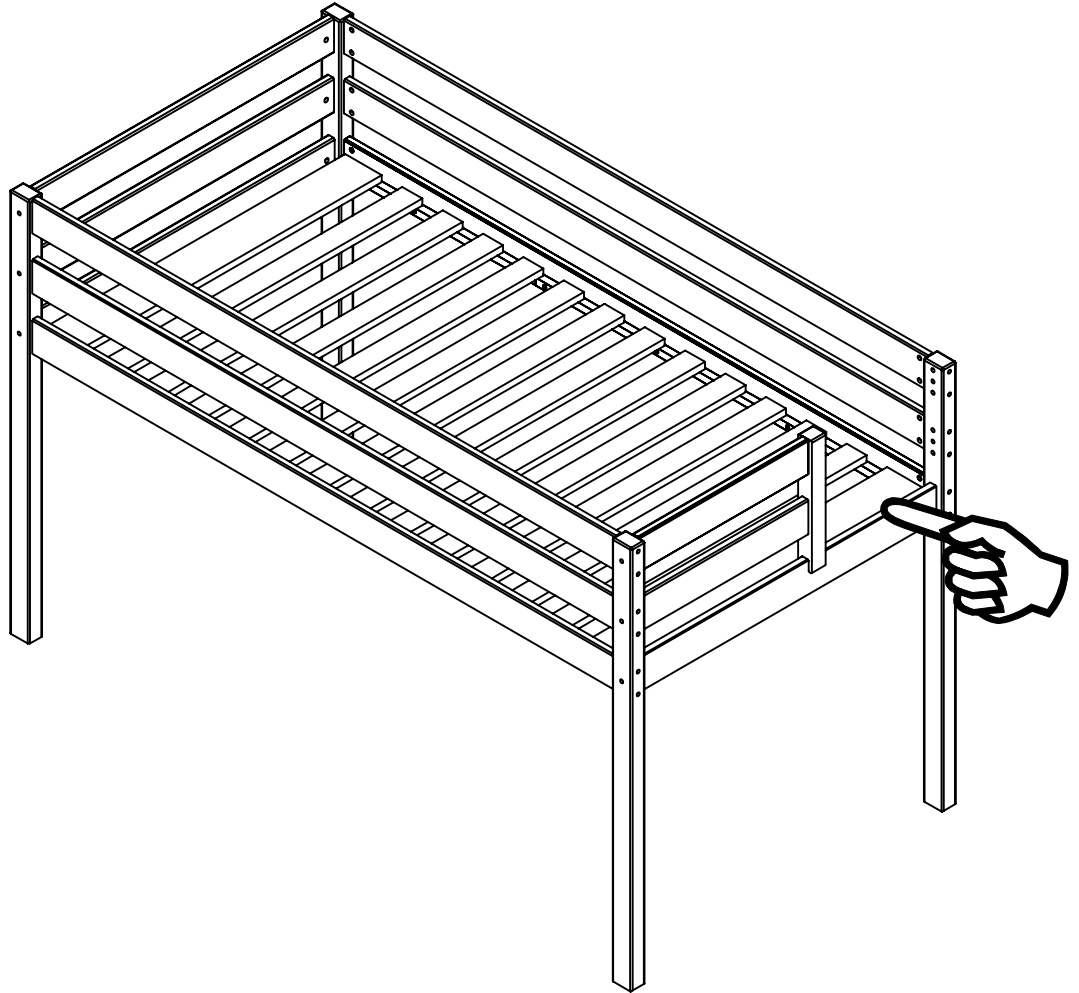

**B**

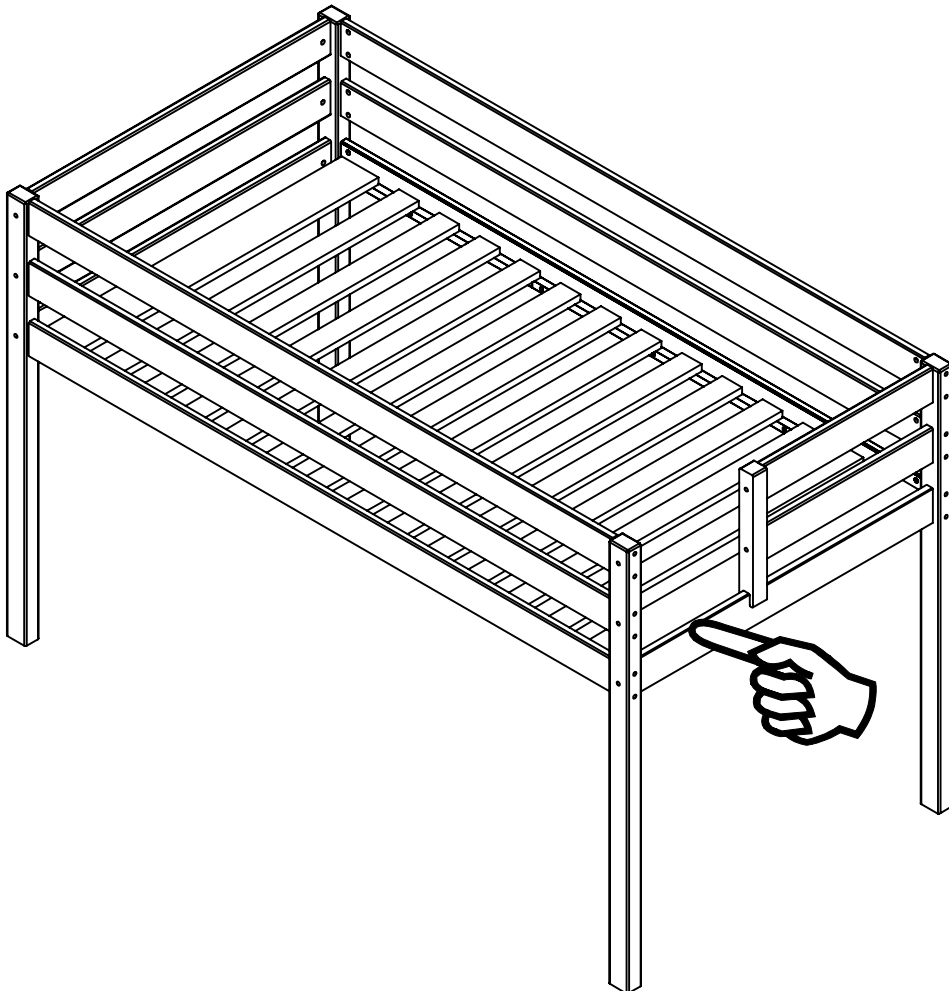

**A**

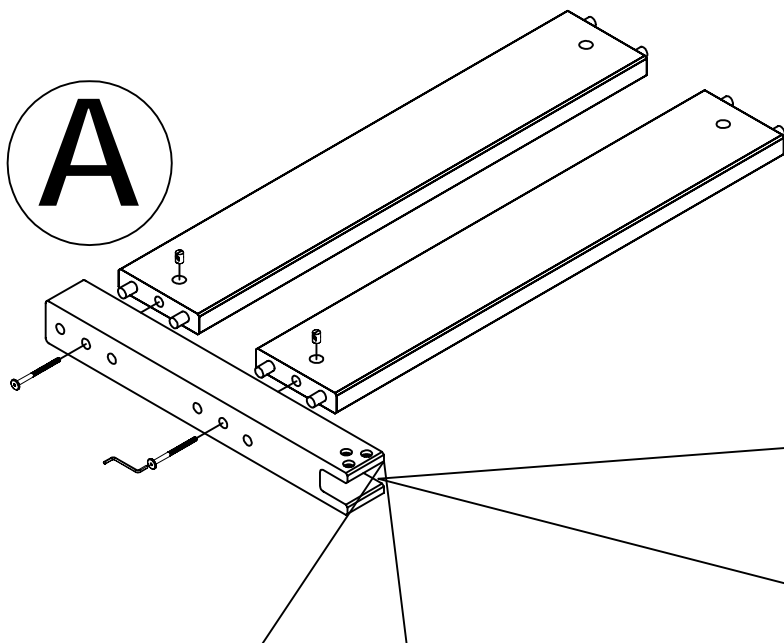

- 20359 (φ8\*17mm) 2X
- 20009 (M8\*110mm) 2X

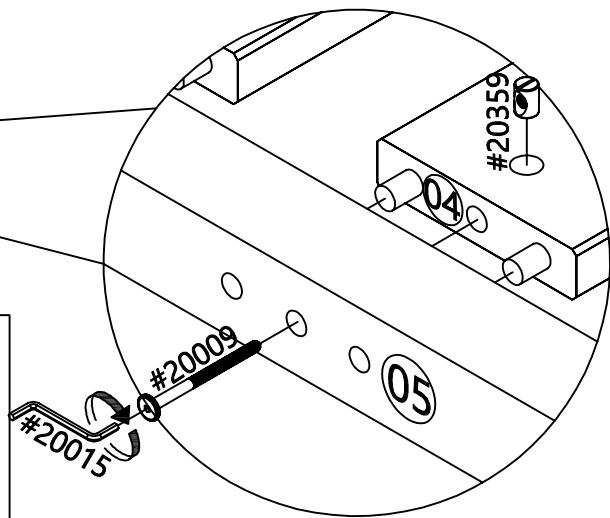
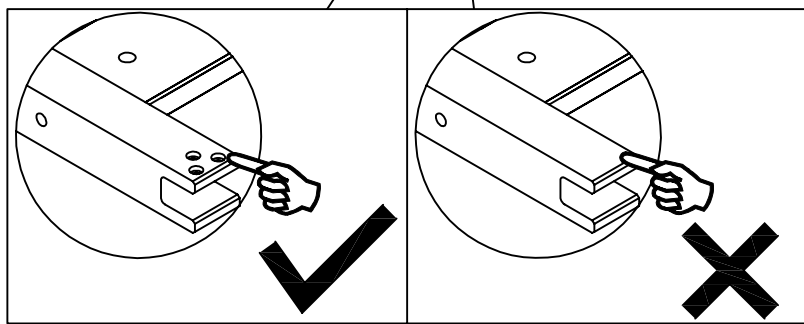

**B**

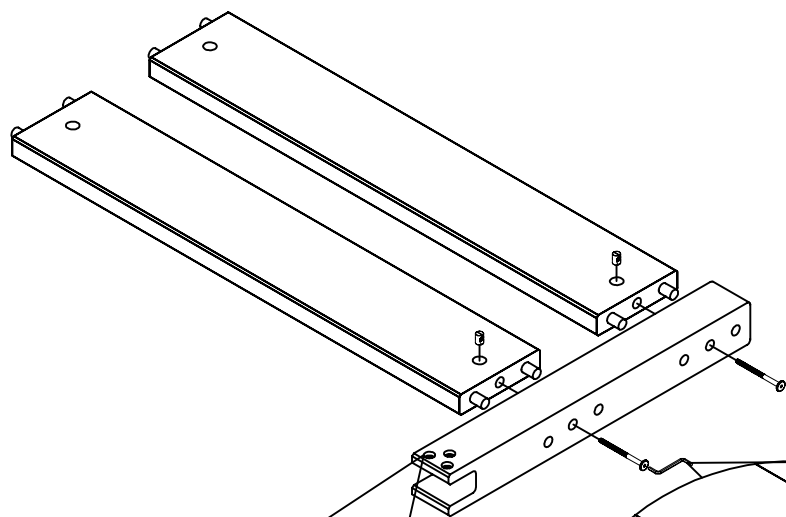

- 20359 (φ8\*17mm) 2X
- 20009 (M8\*110mm) 2X

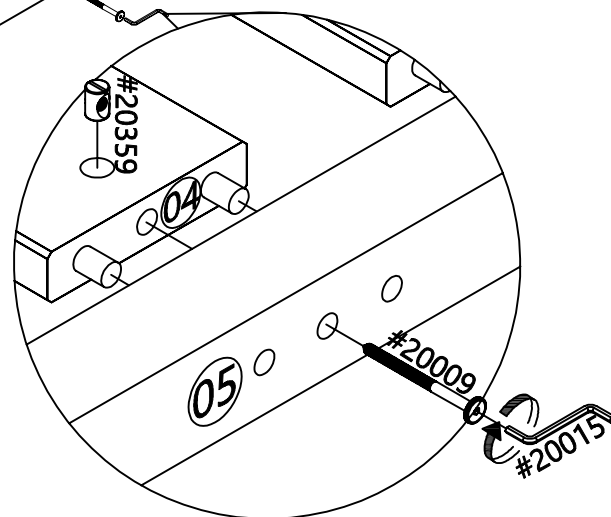
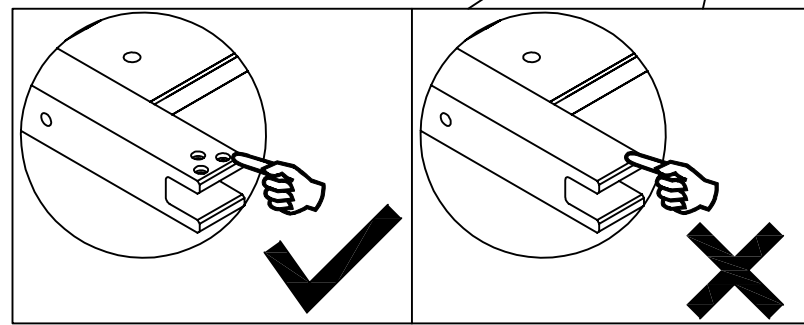

A

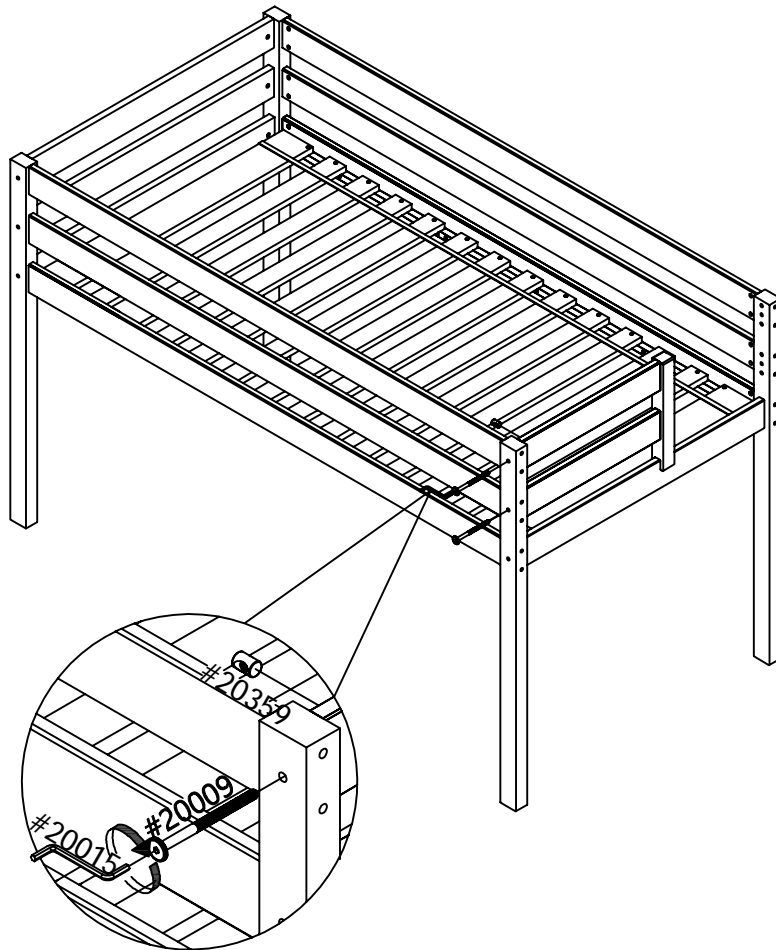

- 2x 20359 (φ8\*17mm)
- 2x 20009 (M8\*110mm)

A

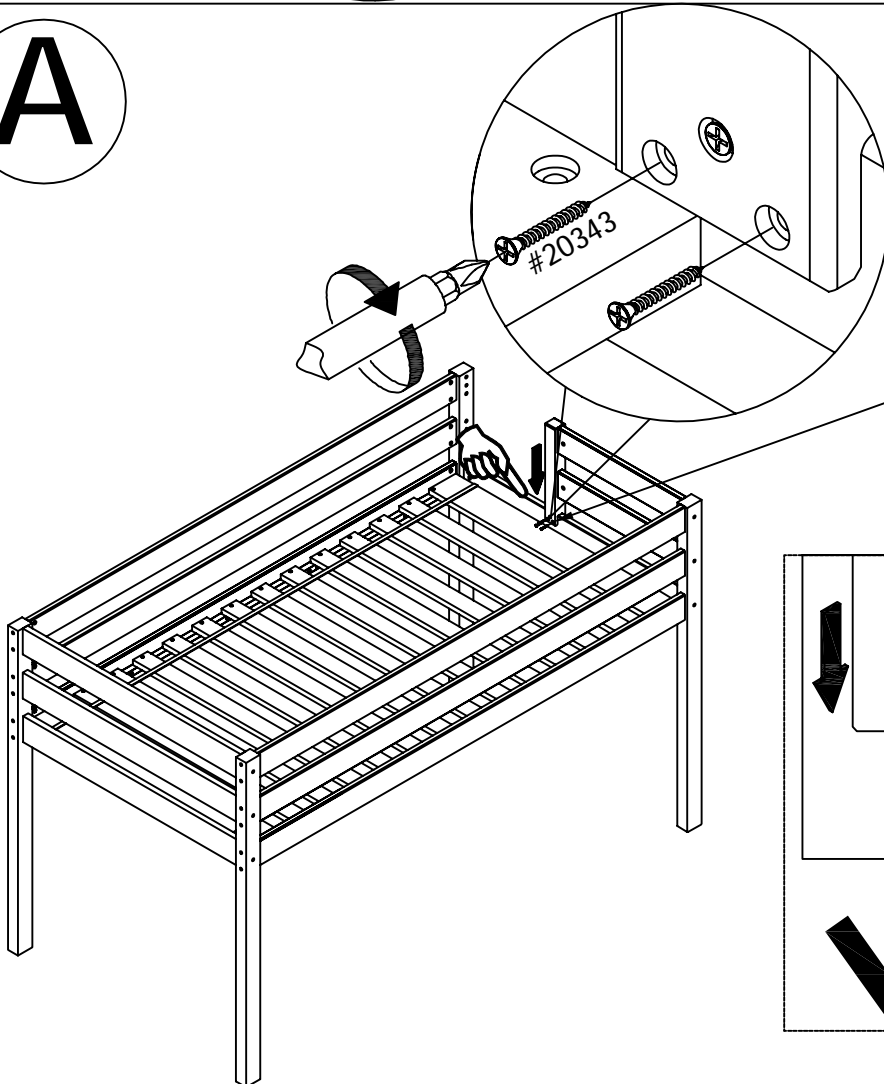

- ~~20055 (4\*30mm)~~
- 3x 20343 (4\*25mm)

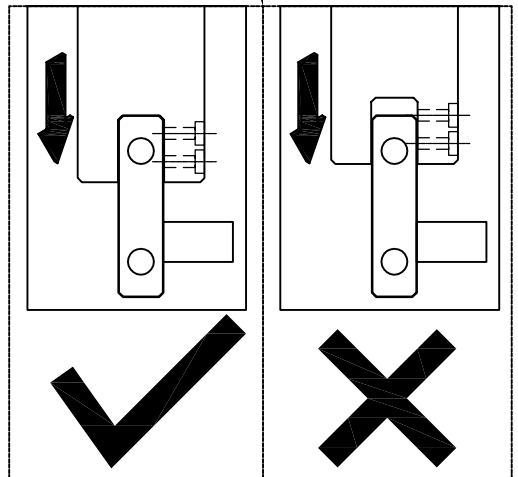

A



12x

20033(φ10\*10mm)

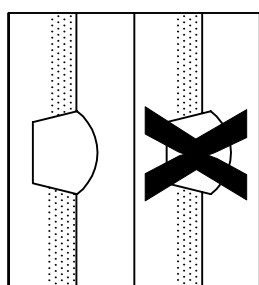
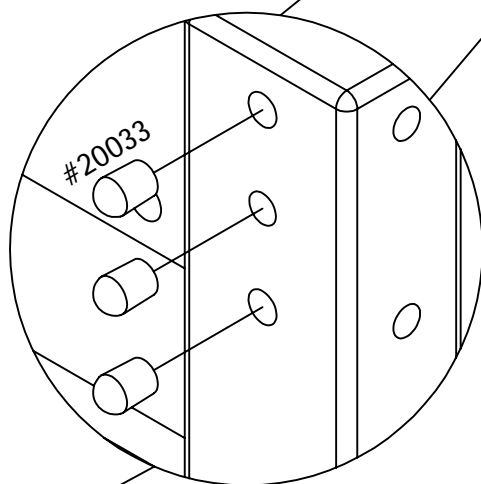
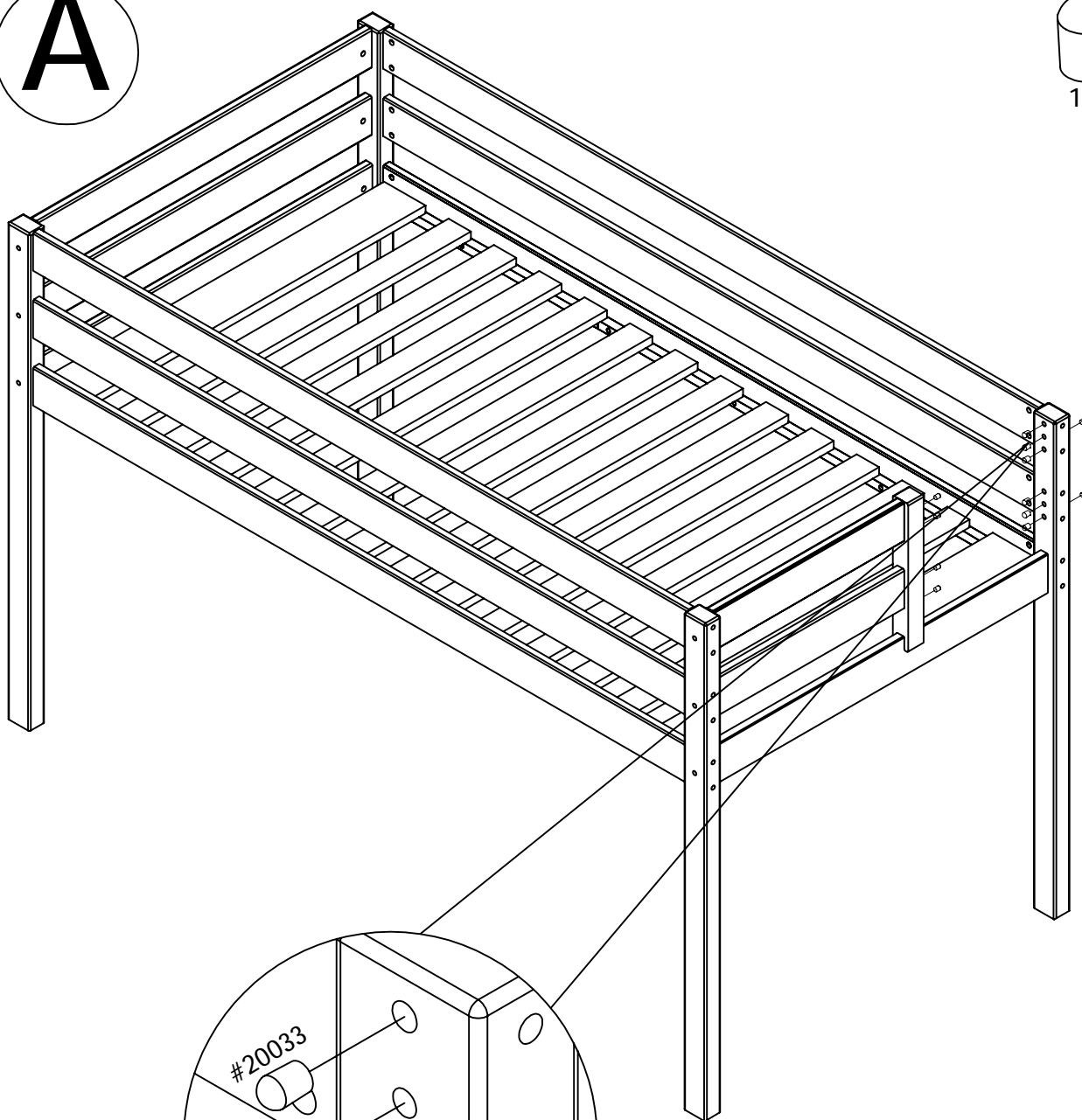

A

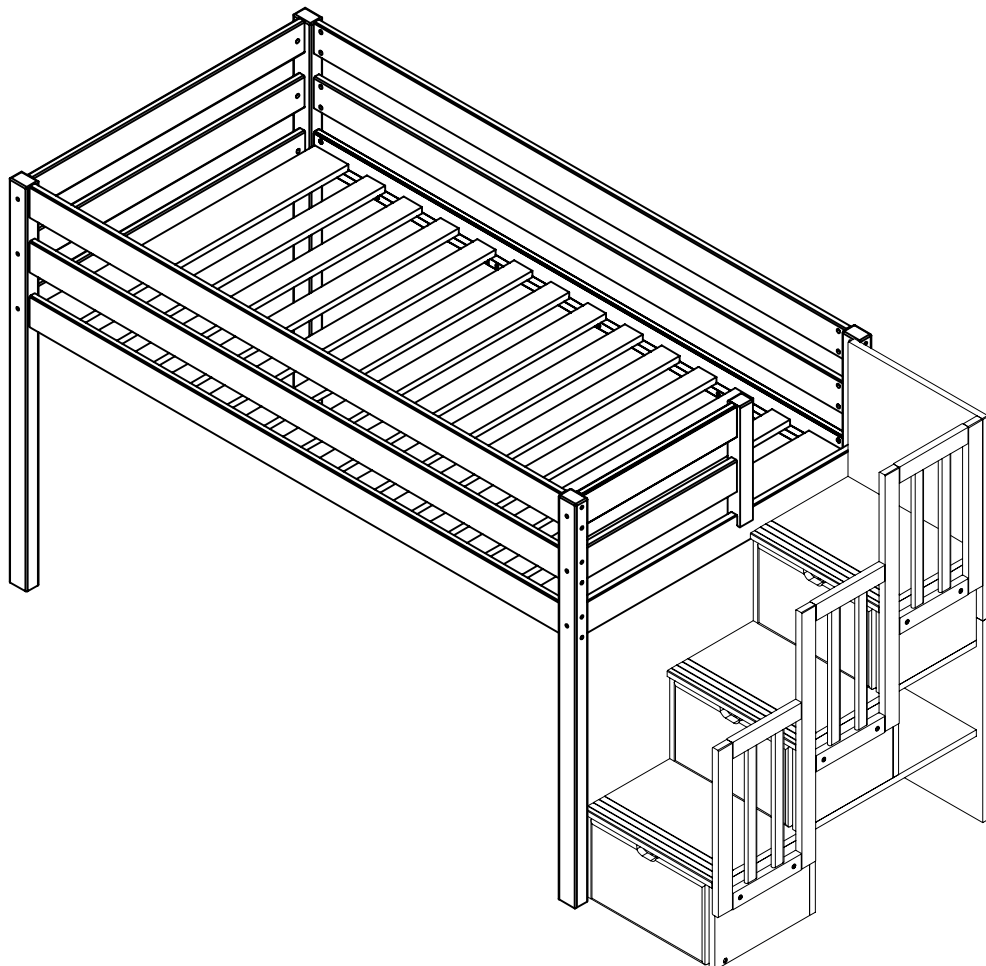
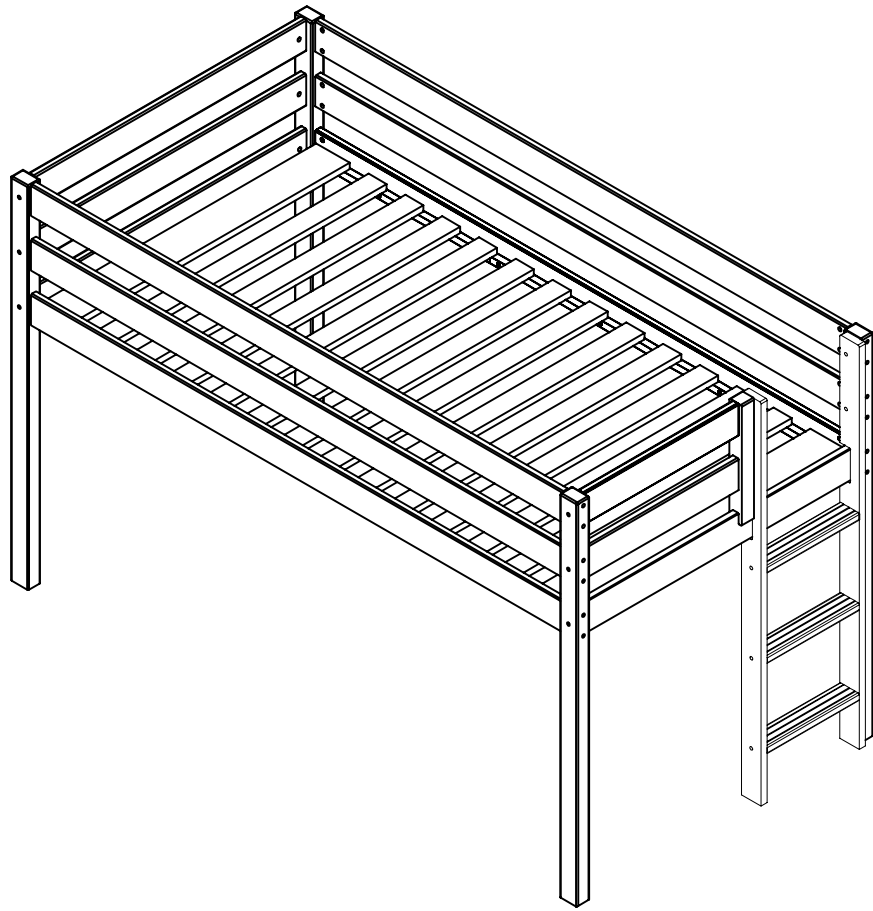

# STRAIGHT LADDER

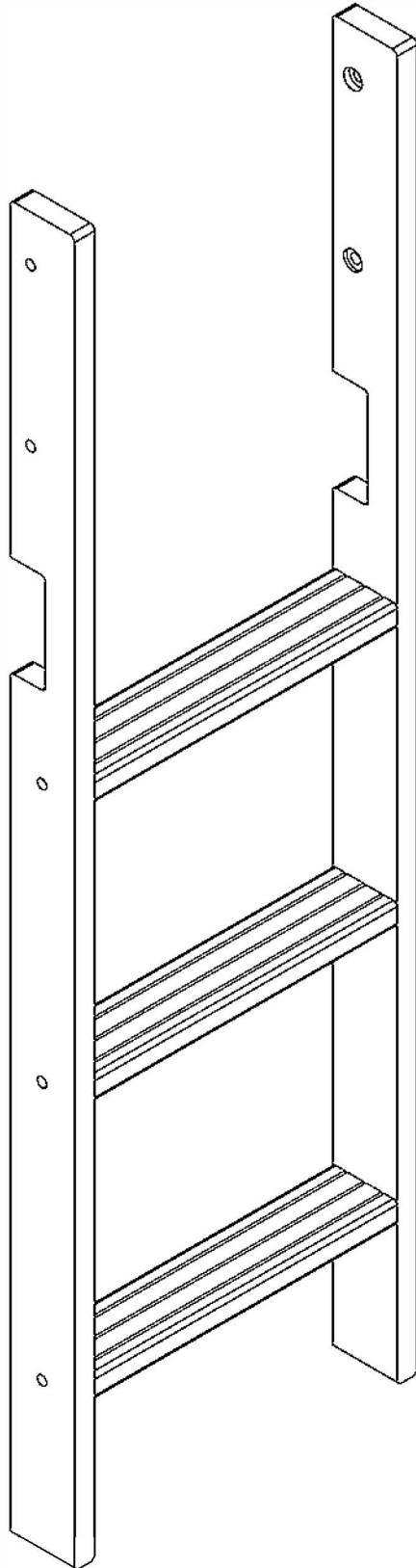

# STRAIGHT LADDER

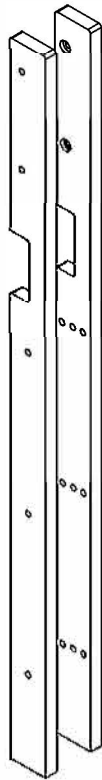

1x

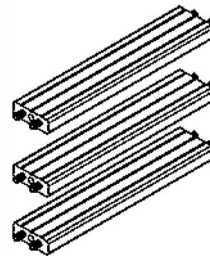

1x

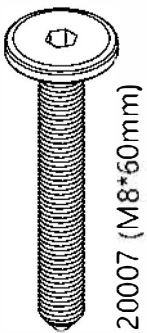

20007 (M8\*60mm)

8x

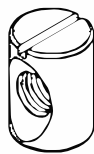

20359 (φ8\*17mm)

6x

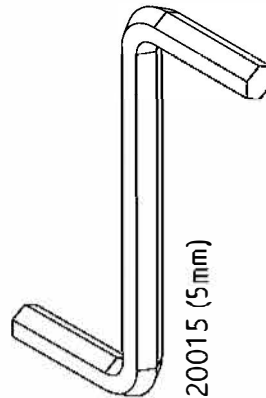

20015 (5mm)

2x

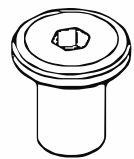

20366(8\*13mm)

2x

**⚠ WARNING:**  
**CHOKING HAZARD--Small Parts**  
 Not for children under 3 years.  
 To be Assembled by an Adult

Not Include  
 Non Inclus  
 No Incluido

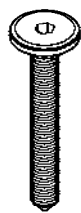

- 
 20359 (φ8×17mm)  
 6x
- 
 20007 (M8×60mm)  
 6x

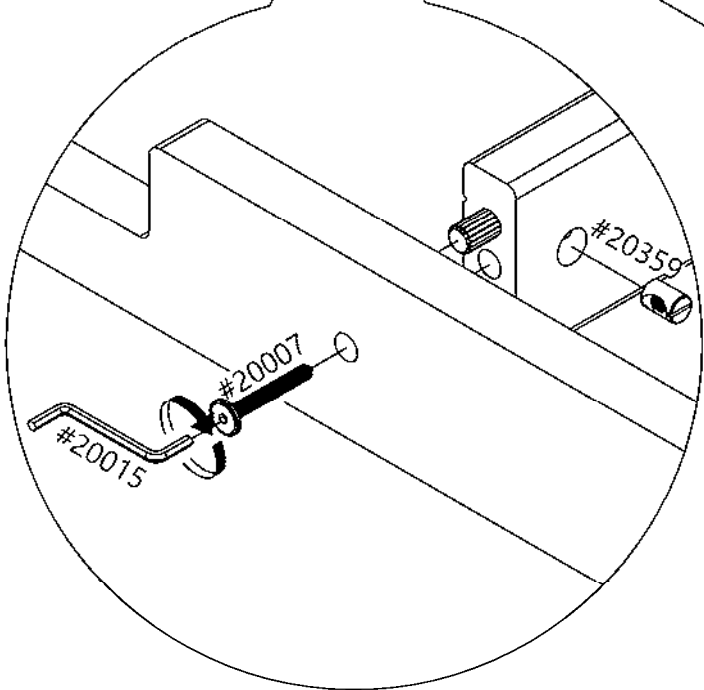
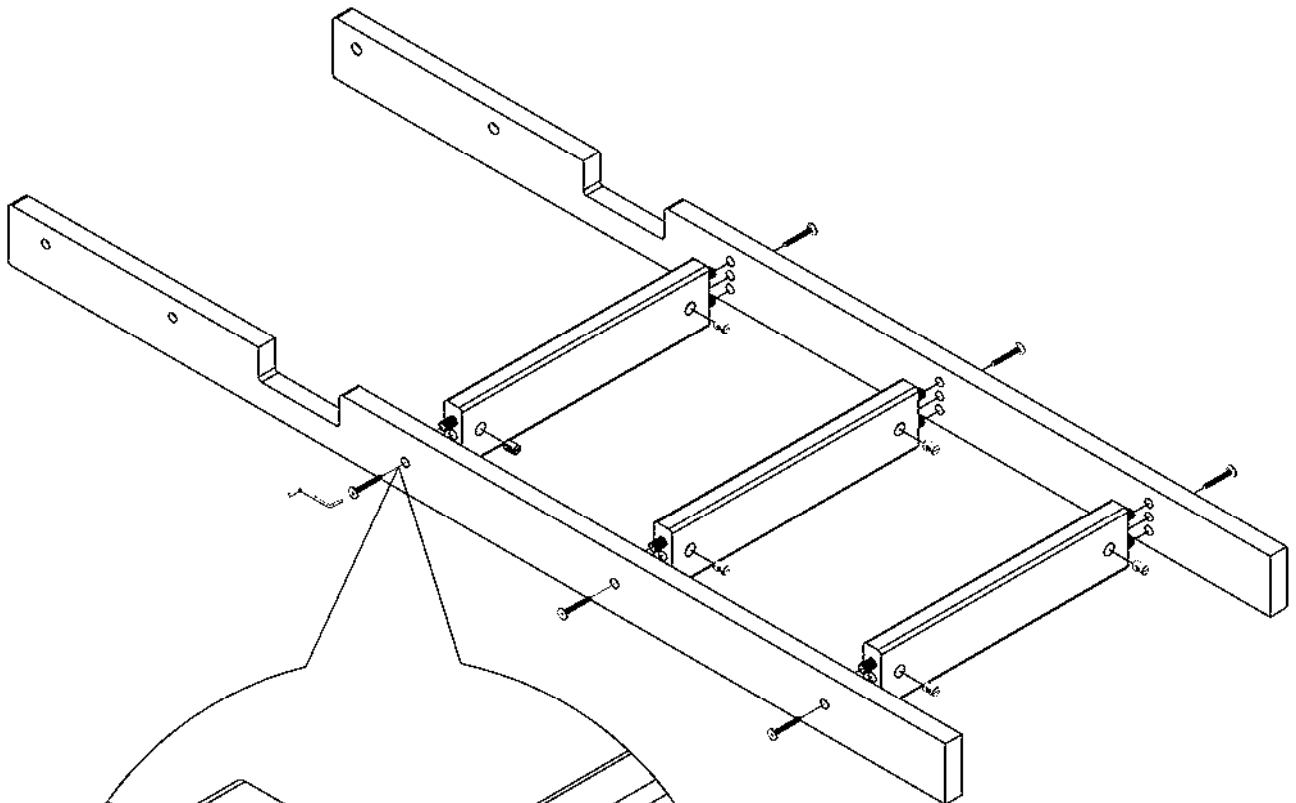

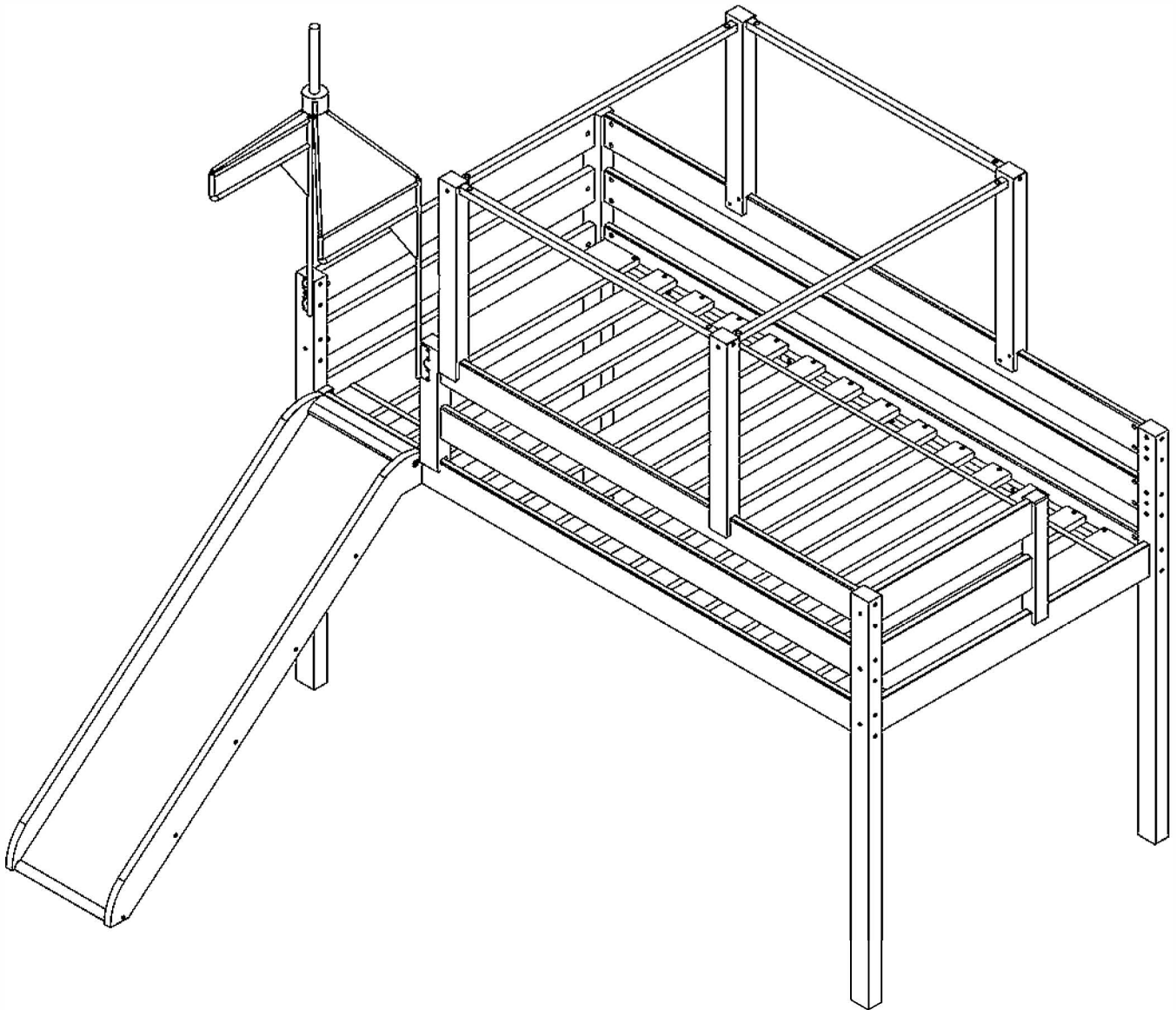

PLEASE SEE ASEMBLY INSTRUCTION  
VEUILLEZ VOIR L'INSTRUCTION D'ASSEMBLAGE POR FAVOR VER  
INSTRUCCIONES DE MONTAJE

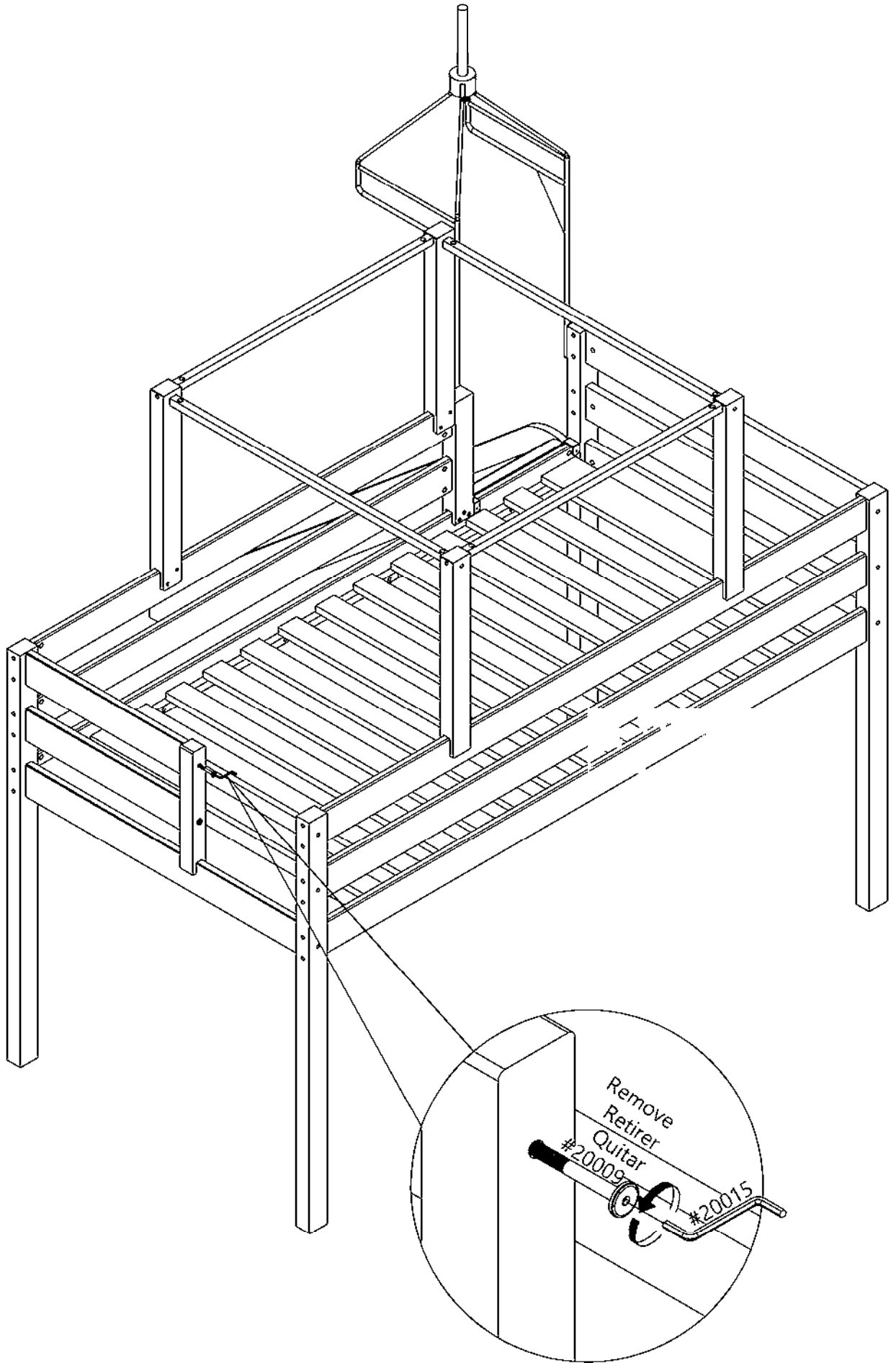

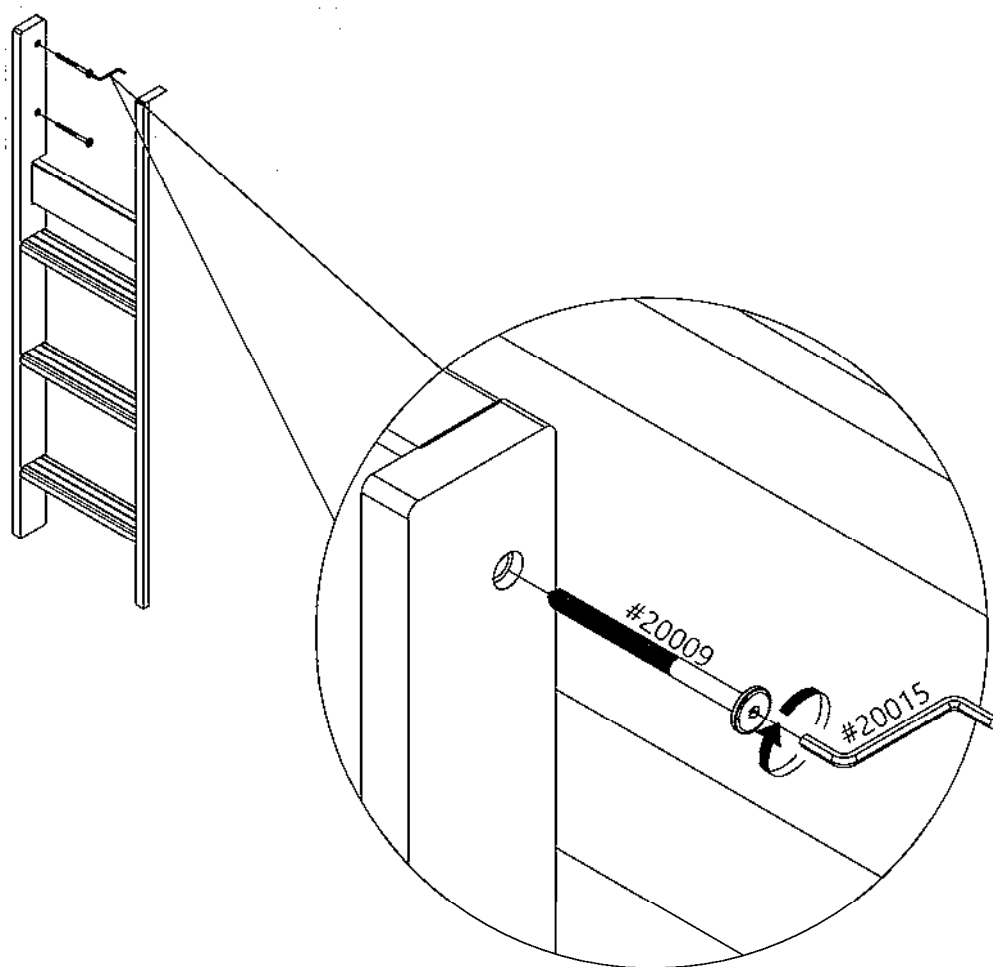
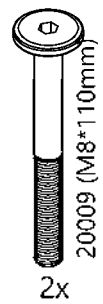

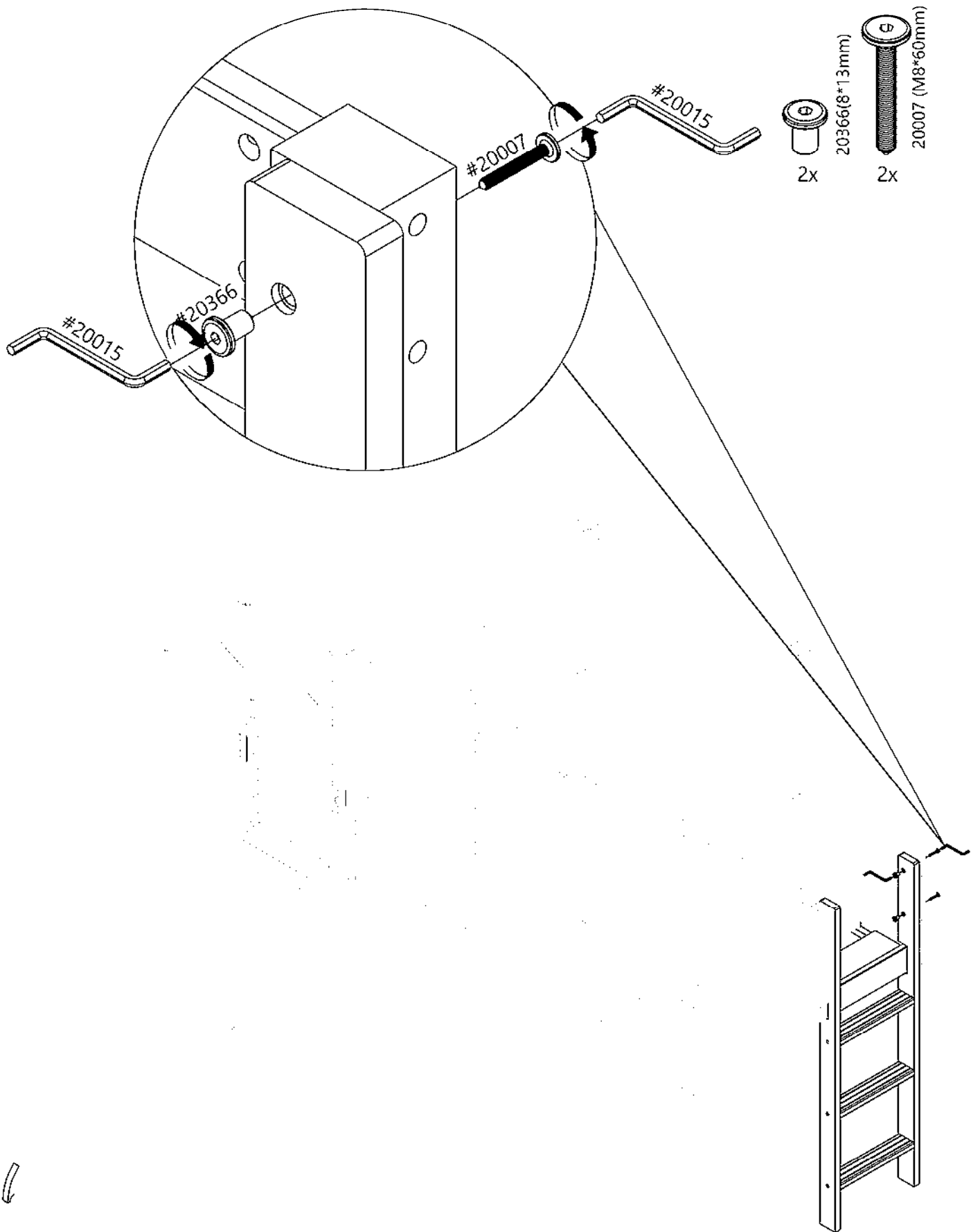

## **ENGLISH**

Thank you for your purchase . We hope you and your kids will love it!  
Please keep these assembly instructions for future reference.

### **Important:**

Safety is our number one concern – please follow these simple safety tips:  
Remember to check and tighten bolts/hardware once every few month, as these may loosen with use over time.  
If you have purchased a bed, chose a low profile mattress for the top bunk (ideally 5" (13cm) or max 10" (25cm))  
to maximize safety rail height.

Make sure to anchor your large dressers to the wall with the free anti-tip kit provided.  
Read and follow the safety instructions on the card attached to the front of your dresser.

---

## **FRANÇAIS**

Merci pour votre achat . Nous espérons que vous et vos enfants l'aimeront.  
Veuillez conserver cette notice de montage pour une consultation ultérieure.

### **Important :**

La sécurité est notre première préoccupation – veuillez suivre ces simples conseils de sécurité :  
N'oubliez pas de vérifier et de serrer les boulons/la quincaillerie une fois tous les deux ou trois mois car ces derniers peuvent se desserrer avec le temps. Si vous avez acheté un lit, choisissez un matelas à profil bas pour le lit d'en haut (idéalement 5" (13 cm) ou maximum 10" (25 cm)) pour maximiser la hauteur du rail de sécurité.

Assurez-vous d'ancrer vos grosses commodes au mur à l'aide de la trousse anti-basculement fournie.

---

## **ESPAÑOL**

Gracias por su compra . Esperamos que usted y sus hijos les encantará.  
Conserve estas instrucciones de montaje para futuras consultas.

### **Importante:**

La seguridad es nuestra preocupación número uno - siga estos sencillos consejos de seguridad:  
Recuerde revisar y apretar tornillos / herrajes una vez cada pocos meses, ya que estos pueden aflojarse con el uso a lo largo del tiempo. Si ha comprado una cama, elija un colchón de perfil bajo para la litera superior (idealmente 5" (13 cm) o máximo 10" (25 cm)) para maximizar la altura del carril de seguridad.

Asegúrese de anclar sus aparadores grandes a la pared con el kit anti-tip gratuito proporcionado. Lea y siga las instrucciones de seguridad de la tarjeta colocada en la parte frontal de la cómoda.

## **ENGLISH**

Size of Mattress and Foundation.

This bed is designed to use a mattress size 74"-75" (188cm – 190cm) long and 37½"-38½" (95cm – 98cm) wide with twin size; 52½"-53½" (133cm – 135cm) wide with full size on upper and lower bunk.

Ensure thickness of mattress and foundation combined does not exceed 10" (25cm) on upper and lower bunk and mattress is at least 5" (13cm) below upper edge of guard rail.

Intended use of Single Beds and Day Beds is Age Group 3 Years and older (36 months and older). Intended use of raised beds including but not limited to Loft Beds and Bunk Beds is 6 Years and older (72 months and older).

## **SAFETY WARNINGS**

1. Follow the information on the warnings appearing on the upper bunk bed end structure and on the carton. Do not remove warning label from bed.
2. Always use recommended size mattress or mattress support, or both, to help prevent the likelihood of entrapment or falls.
3. Surface of mattress must be at least 5" (13cm) below the upper edge of the guardrails.
4. Do not allow children under 6 years of age to use the upper bunk.
5. Periodically check and ensure that the guardrail, ladder and other components are in their proper position, free from damage and that the connectors are tight.
6. Do not allow horseplay on or under the bed and prohibit jumping on the bed.
7. Prohibit more than one person on the upper bunk.
8. Always use the ladder for entering and leaving the upper bunk.
9. Do not use substitute parts. Contact manufacturer or dealer for replacement parts.
10. Use of a night light may provide added safety precaution for a child using the upper bunk.
11. Always use guardrails on both long sides of upper bunk.
12. If the bunk bed will be placed next to a wall, the guardrail that runs the full length of the bed should be placed against the wall to prevent entrapment between the bed and the wall.
13. The use of water or sleep flotation mattresses is prohibited
14. Keep these instructions for future reference.

## **STRANGULATION HAZARD**

15. Never attach or hang items to any part of the bunk bed that are not designed for use with the bed, for example but not limited to hooks, belts, and jump ropes.

## **FRANÇAIS**

Taille du matelas et du support.

Ce lit est conçu pour être utilisé avec un matelas d'une longueur de 74"-75" (188cm à 190cm) et d'une largeur de 37½"-38½" (95cm à 98cm) avec un lit jumeau ; de 52½"-53½" (133cm à 135cm) avec un lit double pour les lits supérieur et inférieur.

Assurez-vous que l'épaisseur combinée du matelas et du support ne dépasse pas 10" (25cm) supérieur et inférieur du lit, et que le matelas soit sous la partie supérieure du rail de sécurité d'au moins 5" (13cm).

Utilisation de Lits Simples et Lits de Repos prévue pour Tranche d'Âge 3 Ans et plus (36 mois et plus) "Utilisation de Lits surélevés comprenant, mais pas exclusivement, des Lits Mezzanine et Lits Superposés prévue pour 6 Ans et plus (72 mois et plus).

## **AVERTISSEMENTS DE SÉCURITÉ**

1. Suivez les avertissements affichés sur la partie supérieure de la structure du lit et sur le carton. Ne retirez pas l'étiquette du lit.
2. Utilisez toujours les tailles recommandées pour le matelas ou le support, ou les deux, pour prévenir les chutes ou le risque de rester coincé.
3. La surface du matelas doit être au moins 5" (13cm) sous la partie supérieure des rails de sécurité.
4. Ne laissez pas des enfants âgés de moins de 6 ans utiliser le lit supérieur.
5. Vérifiez régulièrement et assurez-vous que le rail de sécurité, l'échelle et les autres composants sont en bonne position, sans dommages et que les raccords sont bien serrés.
6. Interdisez tout chahut sur ou sous le lit et interdisez de sauter sur le lit.
7. Interdisez plus d'une personne sur le lit du dessus.
8. Utilisez toujours l'échelle pour accéder au lit supérieur ou pour en descendre.
9. N'utilisez pas de pièces de substitution. Veuillez contacter le fabricant ou le revendeur pour des pièces de remplacement.
10. L'utilisation d'une veilleuse peut offrir une sécurité supplémentaire lorsqu'un enfant utilise le lit supérieur.
11. Utilisez toujours des rails de sécurité des deux côtés longs du lit supérieur.
12. Si le lit superposé est placé à côté d'un mur, le rail de sécurité qui longe tout un côté du lit doit être placé contre le mur pour empêcher d'être coincé entre le lit et le mur.
13. Il est interdit d'utiliser des matelas à eau ou des matelas pneumatiques.
14. Conservez ces instructions pour une référence future.

## **RISQUE D'ÉTRANGLEMENT**

15. N'attachez ou ne pendez jamais d'objets ou toute autre partie du lit superposé qui n'a pas été conçu pour être utilisé avec le lit, par exemple des crochets, des courroies ou des cordes à sauter.

## **ESPAÑOL**

Tamaño del colchón y la base.

Esta cama está diseñada para utilizar un colchón de tamaño 74"-75" (188cm-190cm) de largo y 37½"-38½" (95cm-98cm) de ancho con tamaño sencillo; 52½"-53½" (133cm-135cm) de ancho con tamaño doble en litera de superior e inferior.

Asegúrese que el espesor del colchón y la base combinados no exceda los 10" (25cm) en la parte superior e inferior de la litera y que el colchón esté al menos 5" (13cm) por debajo del borde superior de la barandilla.

El uso previsto de camas individuales y sofás cama es para edades de 3 años o más (36 meses o más). El uso previsto de camas elevadas, incluidas, entre otras, las camas altas y literas es de 6 años o más (72 meses o más).

## **ADVERTENCIAS DE SEGURIDAD**

1. Siga la información en las advertencias que aparecen en la estructura final superior de la cama de la litera y en la caja de cartón. No retire la etiqueta de advertencia de la cama.
2. Utilice siempre el tamaño del colchón o del soporte del colchón recomendados, o ambos, para ayudar a prevenir el riesgo de atrapamiento o caída.
3. La superficie del colchón debe de ser de al menos 5" (13cm) pulgadas por debajo del borde superior de las barandas.
4. No permita que los niños menores de 6 años de edad utilicen la *litera superior*.
5. Periódicamente verifique y asegúrese que la barandilla, escalera y otros componentes estén en su posición correcta, libre de daños y que los conectores estén apretados.
6. No permita juegos bruscos en o debajo de la cama y prohíba saltar en la cama.
7. Prohíba más de una persona en la litera superior.
8. Siempre use la escalera para entrar y salir de la litera de arriba.
9. No utilice piezas de sustitución. Consulte al fabricante o al distribuidor para pedir piezas de repuesto.
10. El uso de una luz de noche puede proporcionar seguridad adicional para un niño que usa la litera superior.
11. Utilice siempre barandas largas a ambos lados de litera superior.
12. Si la litera se coloca al lado de una pared, la barandilla que recorre toda la longitud de la cama debe de ser colocada contra la pared para evitar el atrapamiento entre la cama y la pared.
13. Está prohibido el uso de colchones de agua o de flotación
14. Guarde estas instrucciones como referencia futura.

## **PELIGRO DE ESTRANGULACIÓN**

15. Nunca una ni cuelgue objetos a ninguna parte de la litera que no estén diseñados para su uso con la cama, por ejemplo, pero no limitado a ganchos, cinturones y cuerdas para saltar.

# ASSEMBLY INSTRUCTION

## UNDERBED CURTAIN

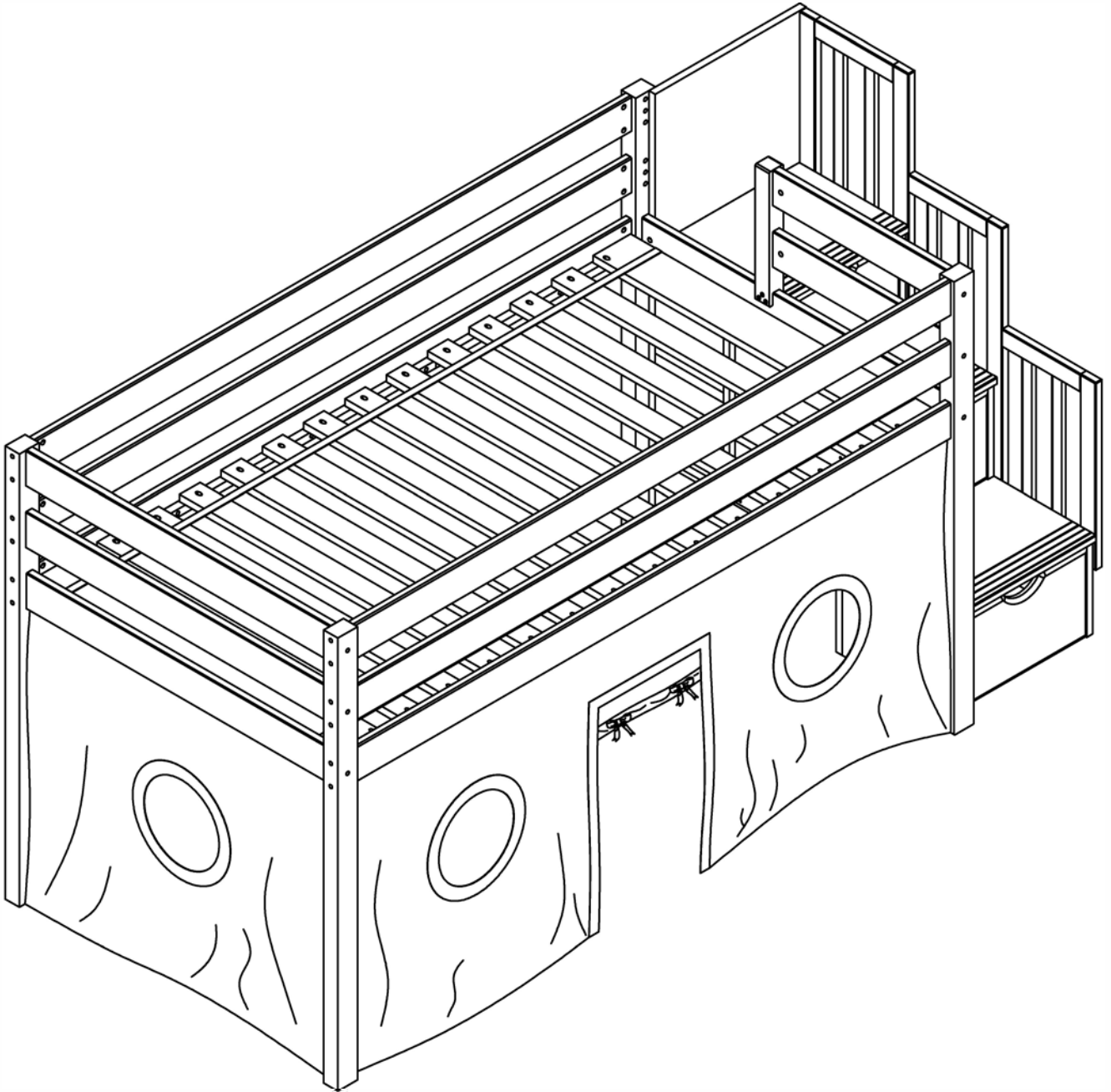

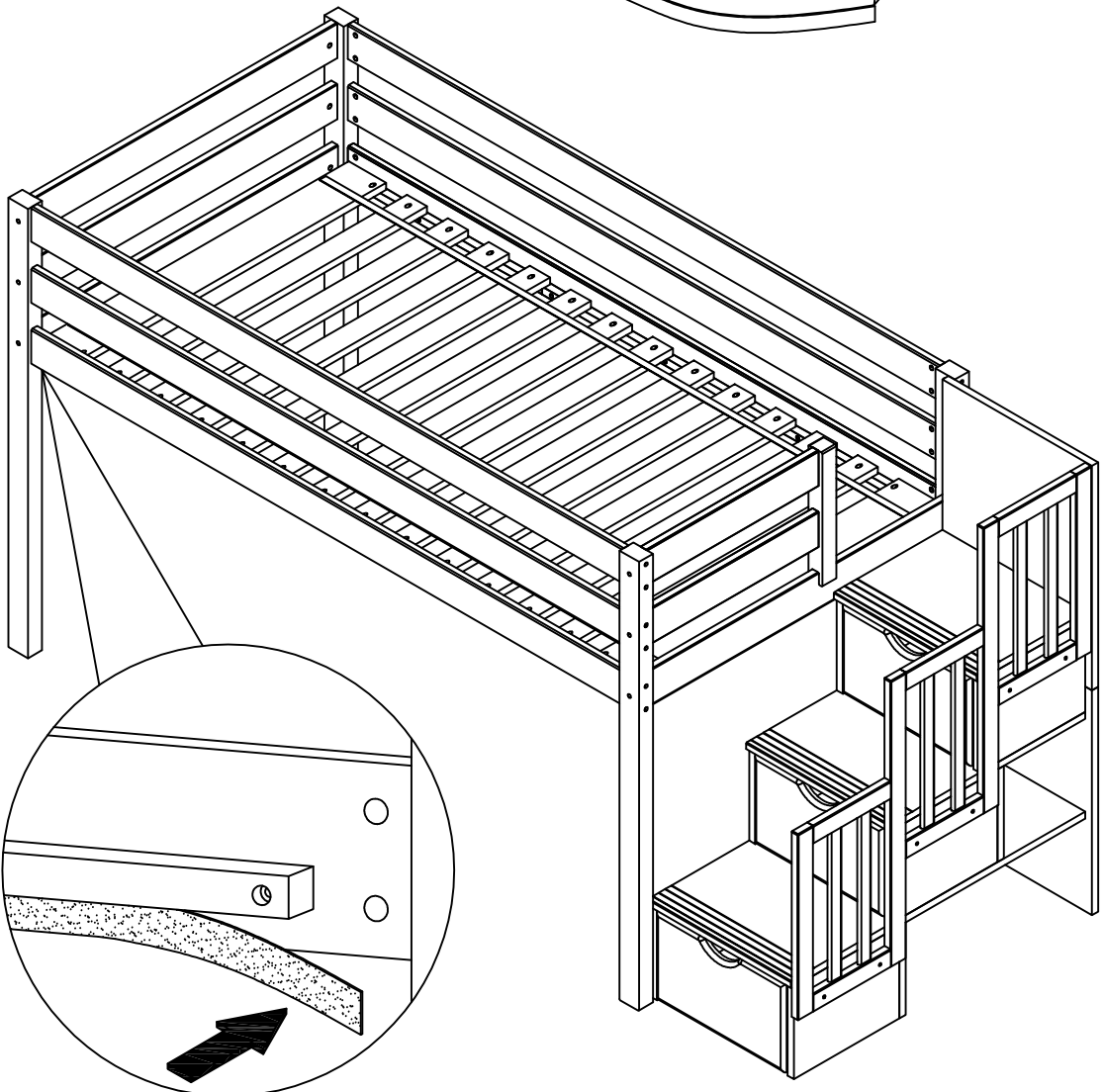
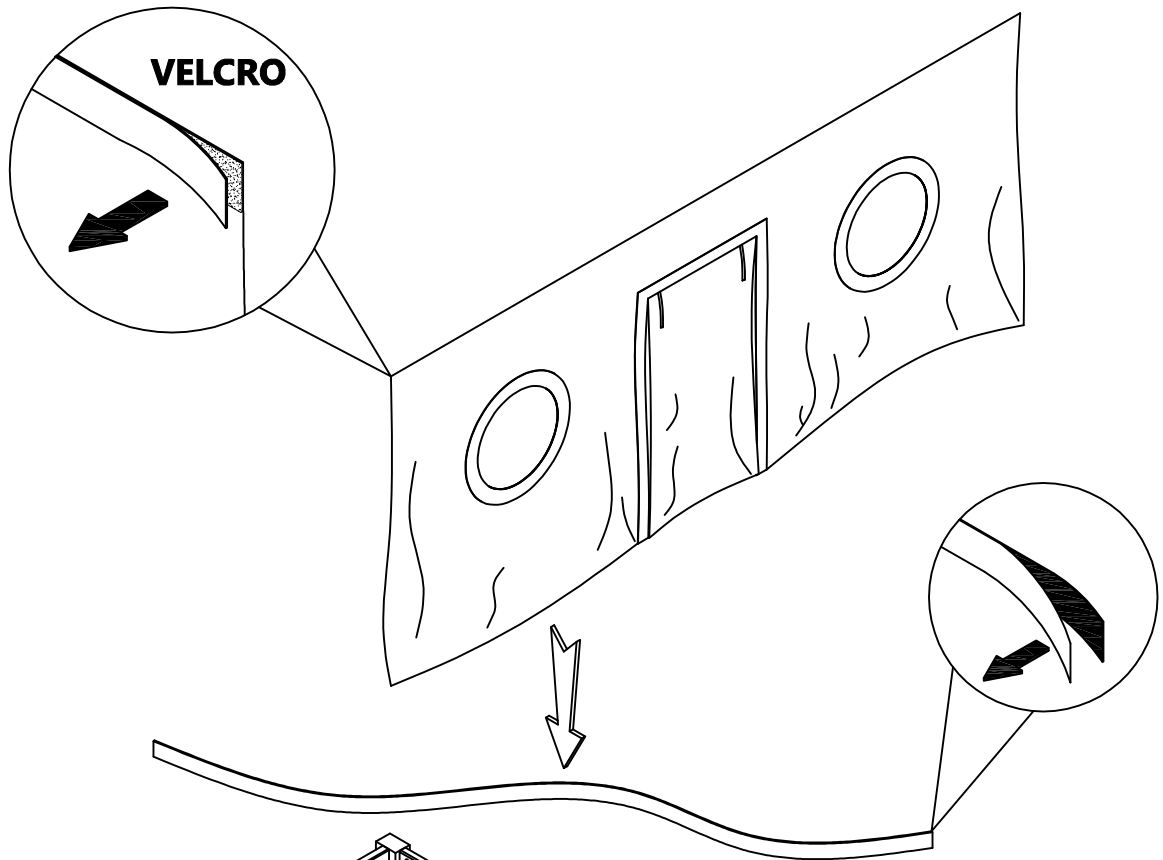

- **Attach Velcro to the bottom of the bedside rail.**
- **Do not attach the curtain for 60 minutes!**

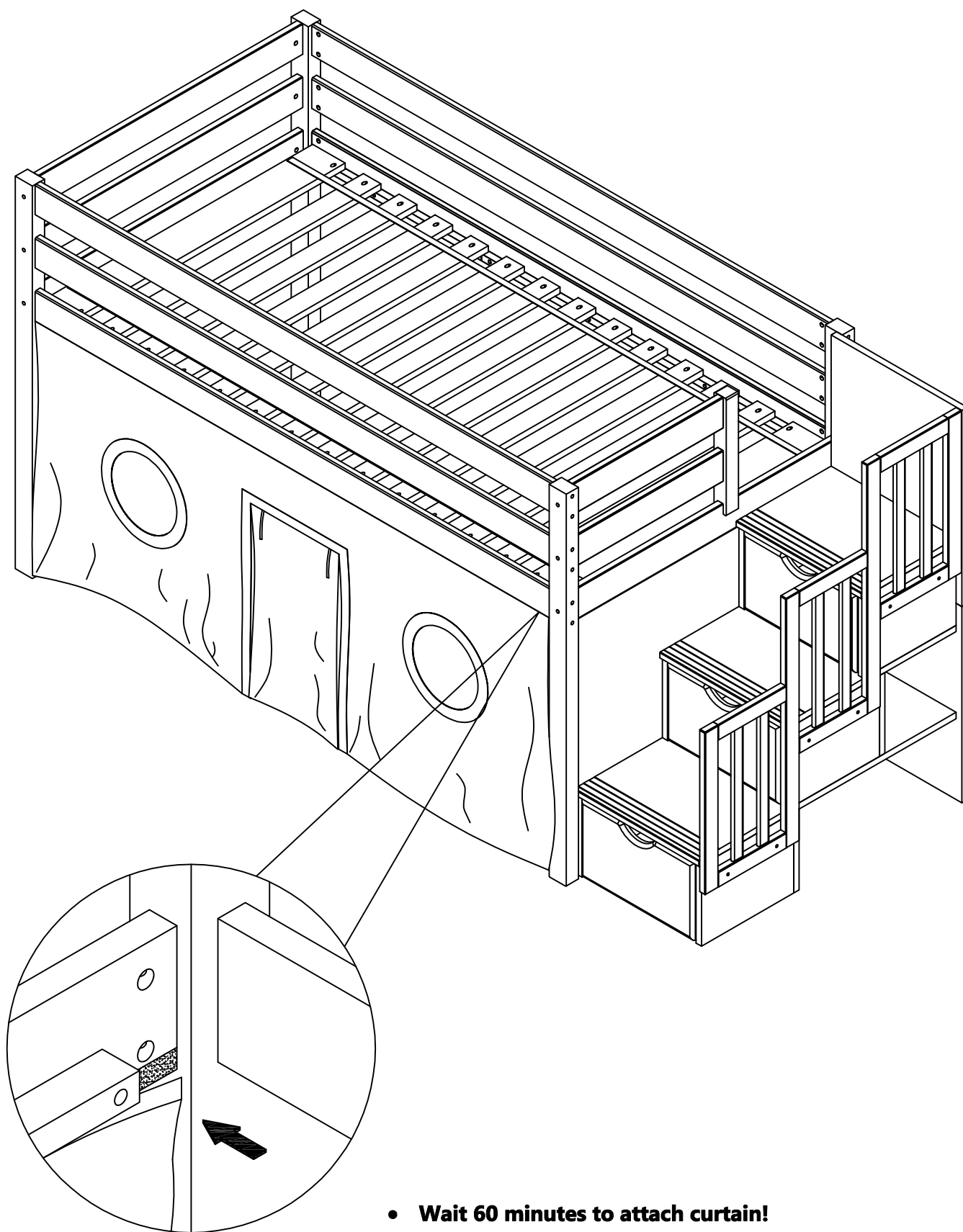

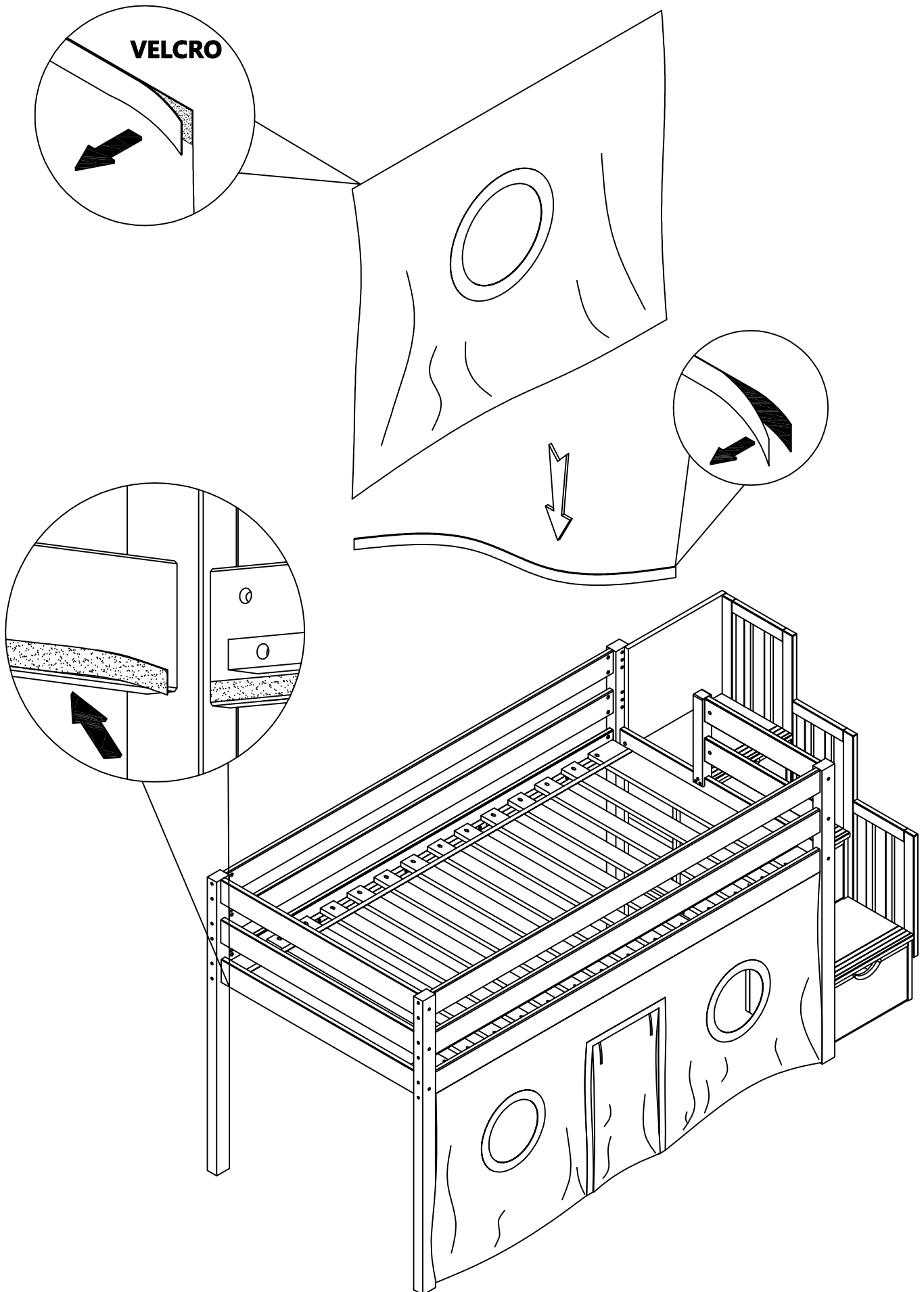

- **Attach Velcro to the bottom of the bedside rail.**
- **Do not attach the curtain for 60 minutes!**

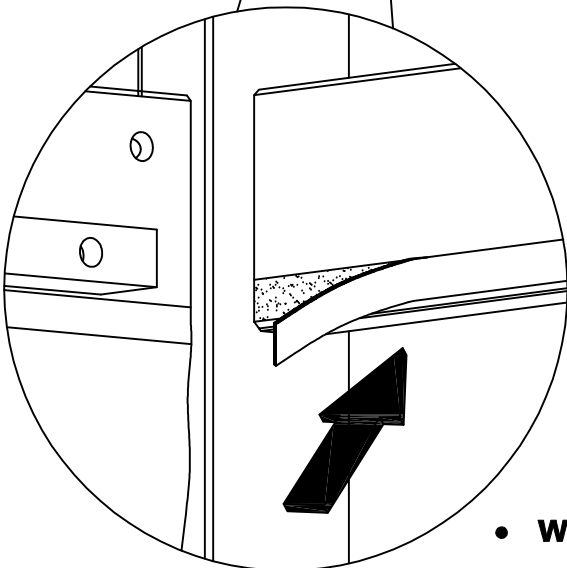
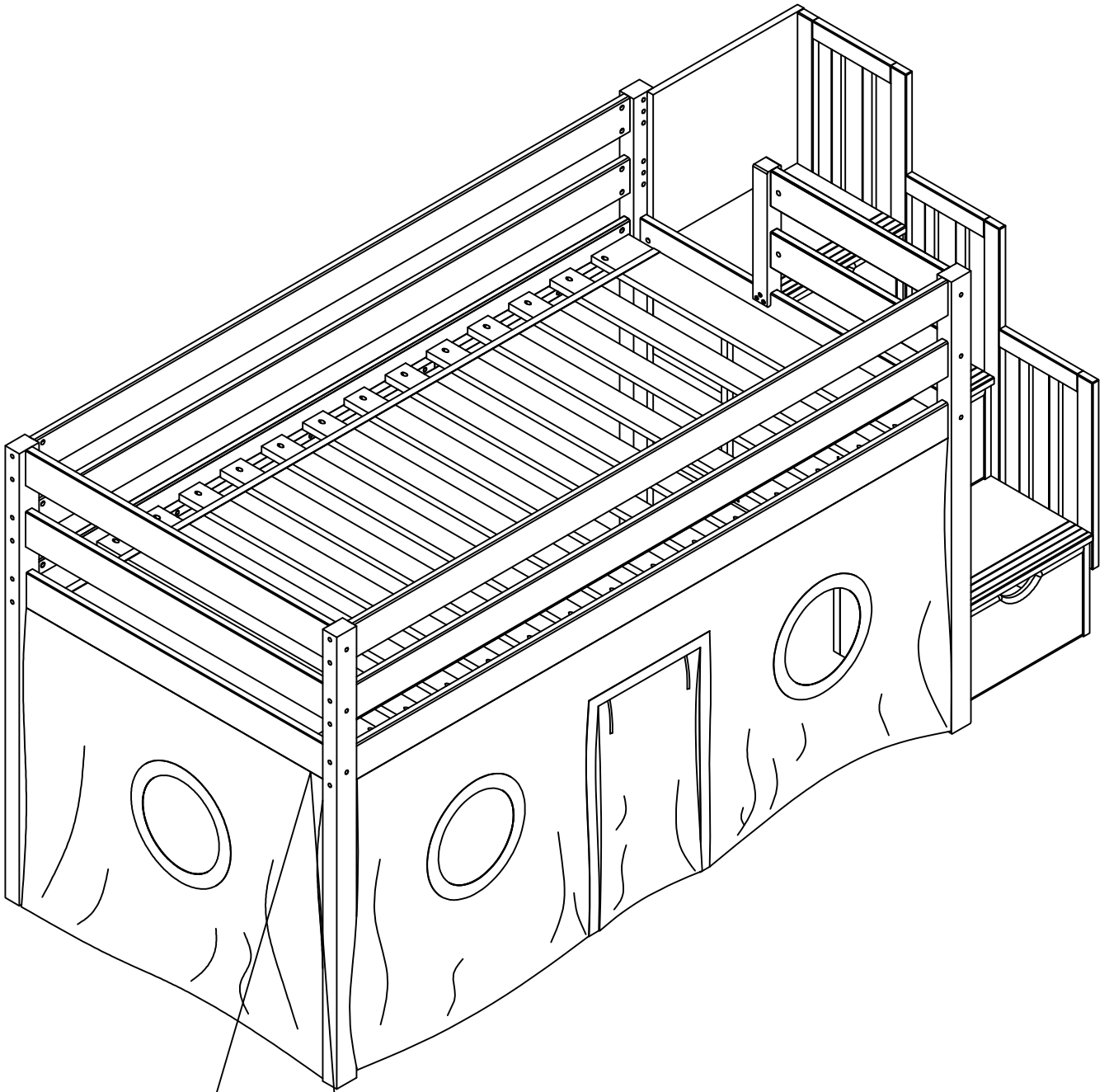

- **Wait 60 minutes to attach curtain!**