

Assembly Instructions

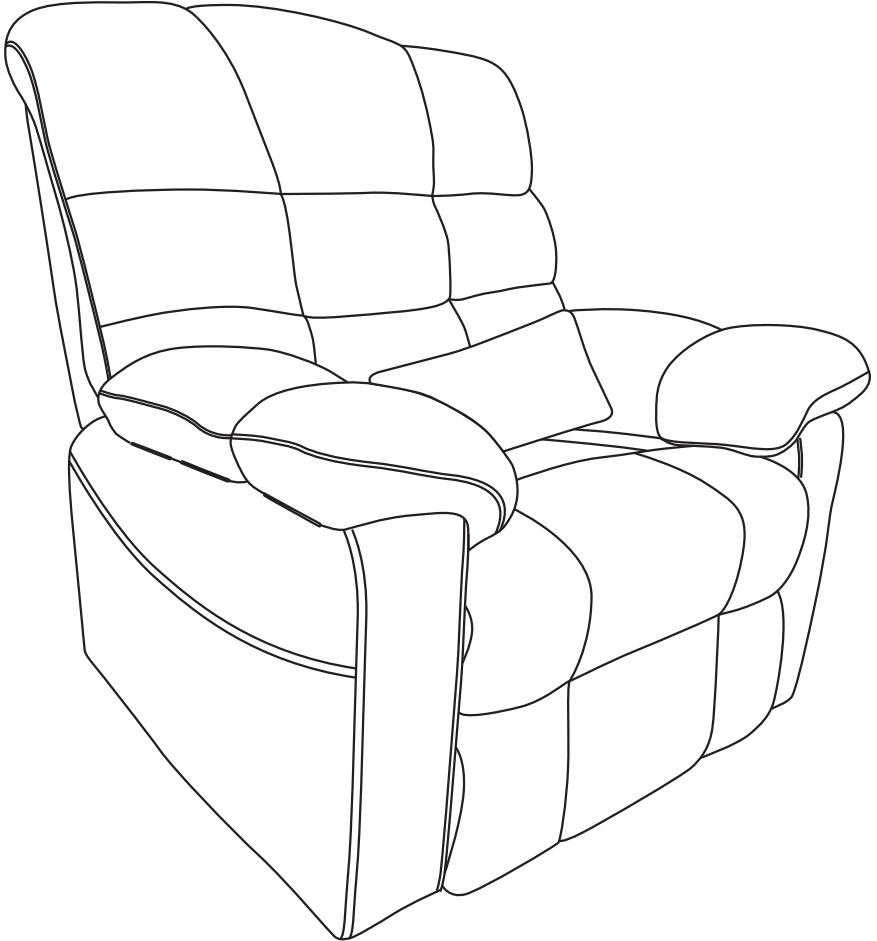

THIS INSTRUCTION BOOKLET CONTAINS **IMPORTANT** SAFETY INFORMATION.
PLEASE READ AND KEEP FOR FUTURE REFERENCE.

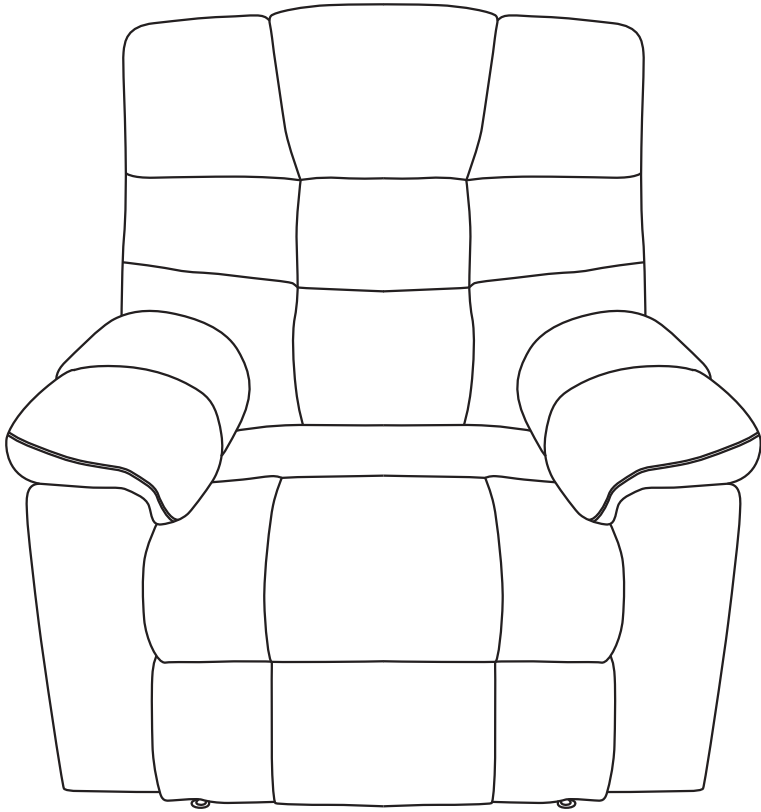







GENERAL ASSEMBLY INFORMATION GUIDE

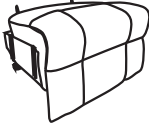

Please read the following instructions prior to assembling this product:

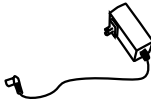
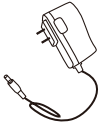
1. To avoid damage, assemble this product on a non-abrasive surface such as carpet.
2. Make sure all bolts are tightly fastened before use.
3. For home use or light commercial use only.
4. Please make sure you have all parts before assembly.

Package Contents

			
A1*ChairSeat	B1*LeftArmrest	C1*RightArmrest	D1*Backrest
Box1	Box2		Box3
			
E 1*Power Supply	F 1*Power Plug	G 1*Massage	H 1*Remote
			
I 2*Supporting Feet			
J 4*Nuts	K 4*Screws		

Please find the spare parts at the bottom of the seat(Box1).
Step 1 Remove this hardboard before assembly.

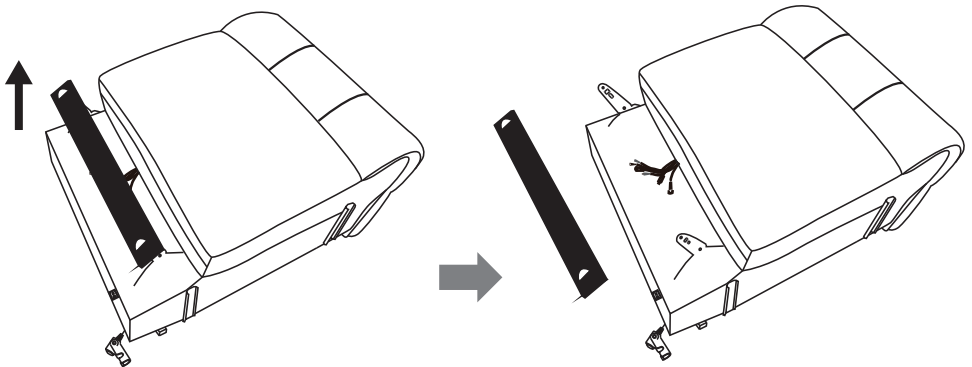

Step2 Assemble the anti-toppling feet.

Take out anti-toppling feet(I),nuts(J),and screws(K) from a yellow accessory bag packed in the Box1.

Assemble the two anti-toppling feet shown on the machine' s bottom to avoid toppling and falling.

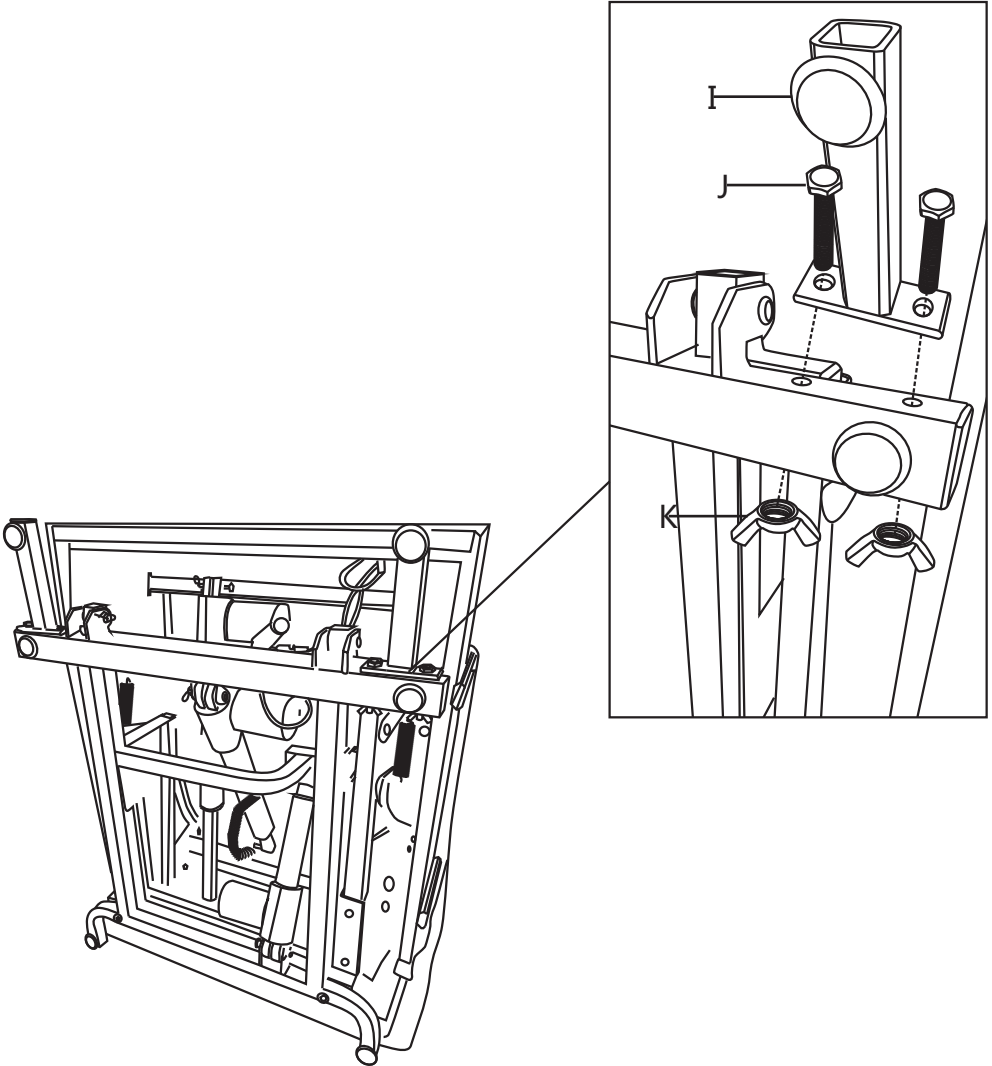

Step3 Assemble the armrests.

Connect the Armrests(B&C) to the chair seat(A) by aligning the metal grooves and sliding down to the bottom.

PS: Pls ask another adult to pull the top cushion of the seat aside so that you can see clearly the metal grooves, it will be easier to make it, pls align the front metal groove first instead of the back one.

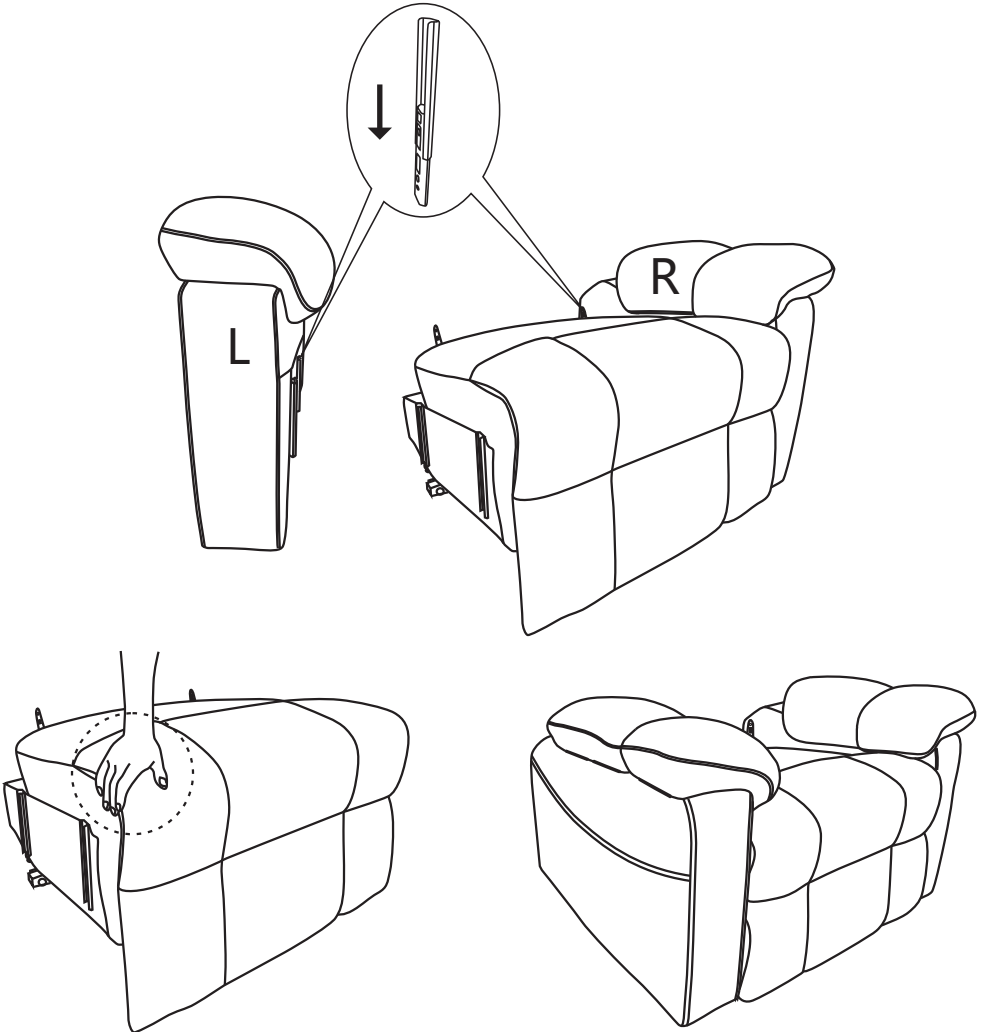

Step4

Connect the chair backrest(D) to the chair seat(A) by aligning the metal grooves(M&N) and sliding down to the bottom.

PS: If the metal groove M slides down to the bottom of metal groove N, the backrest will not be taken off easily.

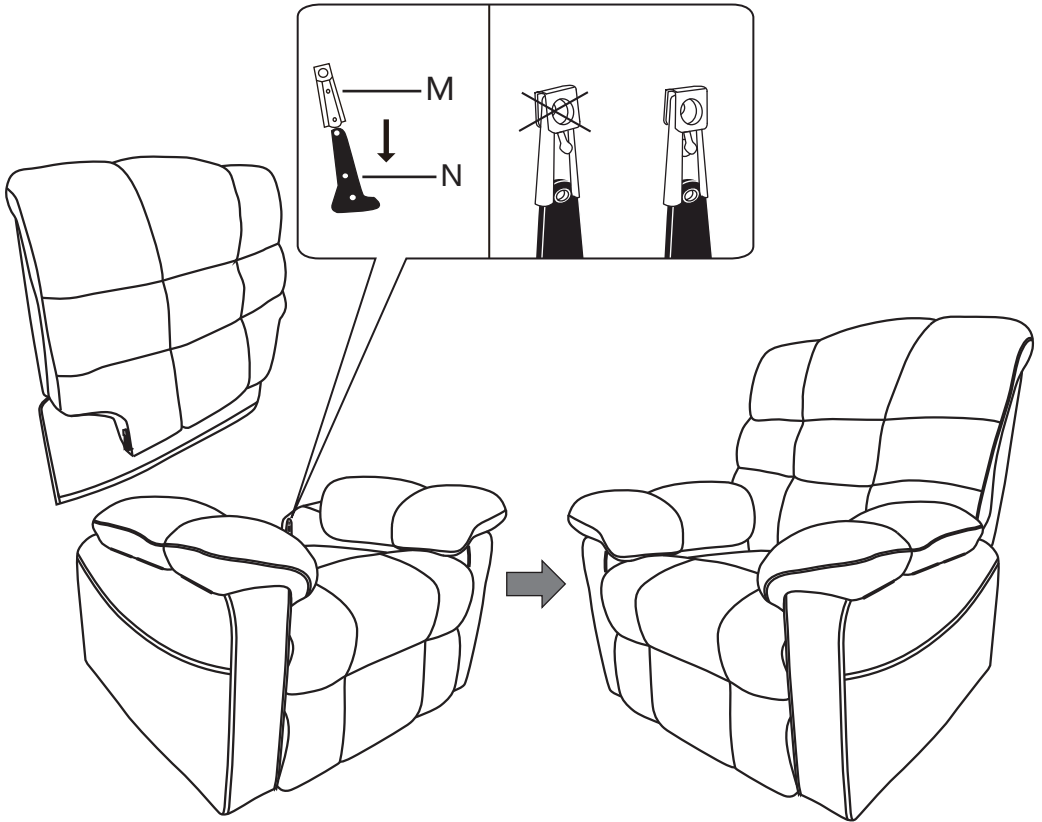

Step5

Kindly remind that you can put the pillow to the gap between the backrest and seat to support your body when you recline the chair

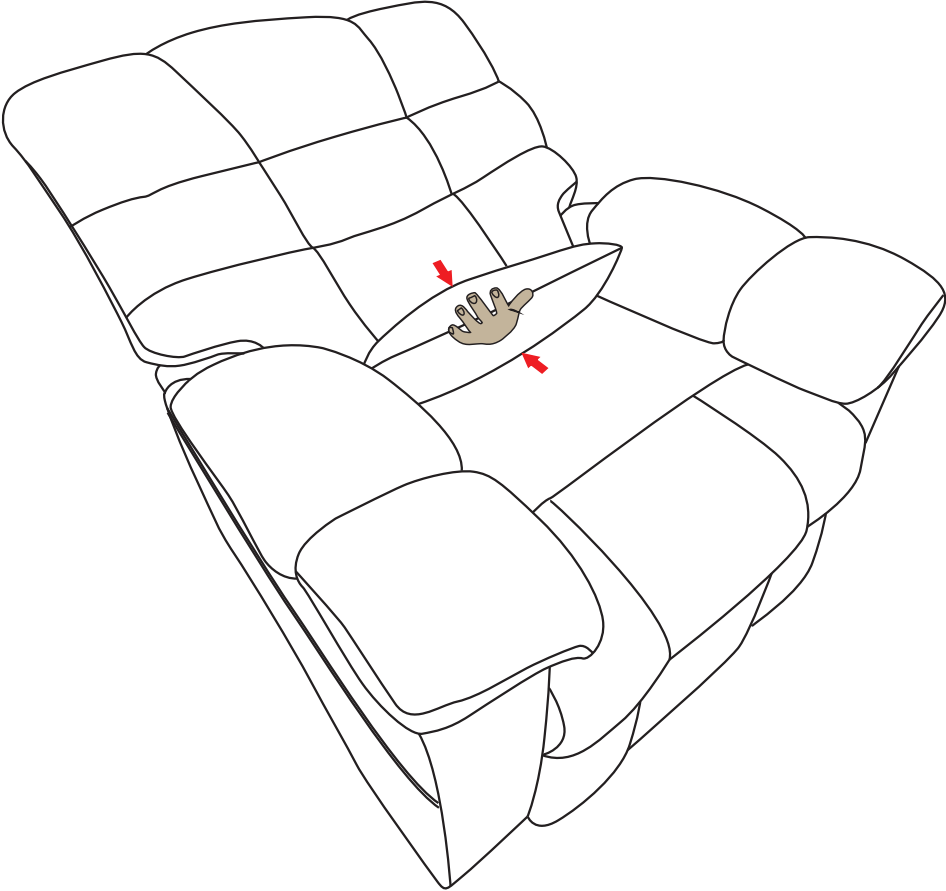

Step6

Because the backrest is filled with doll cotton, 3cm difference is allowed, and you can slap the higher part to align the backrest.

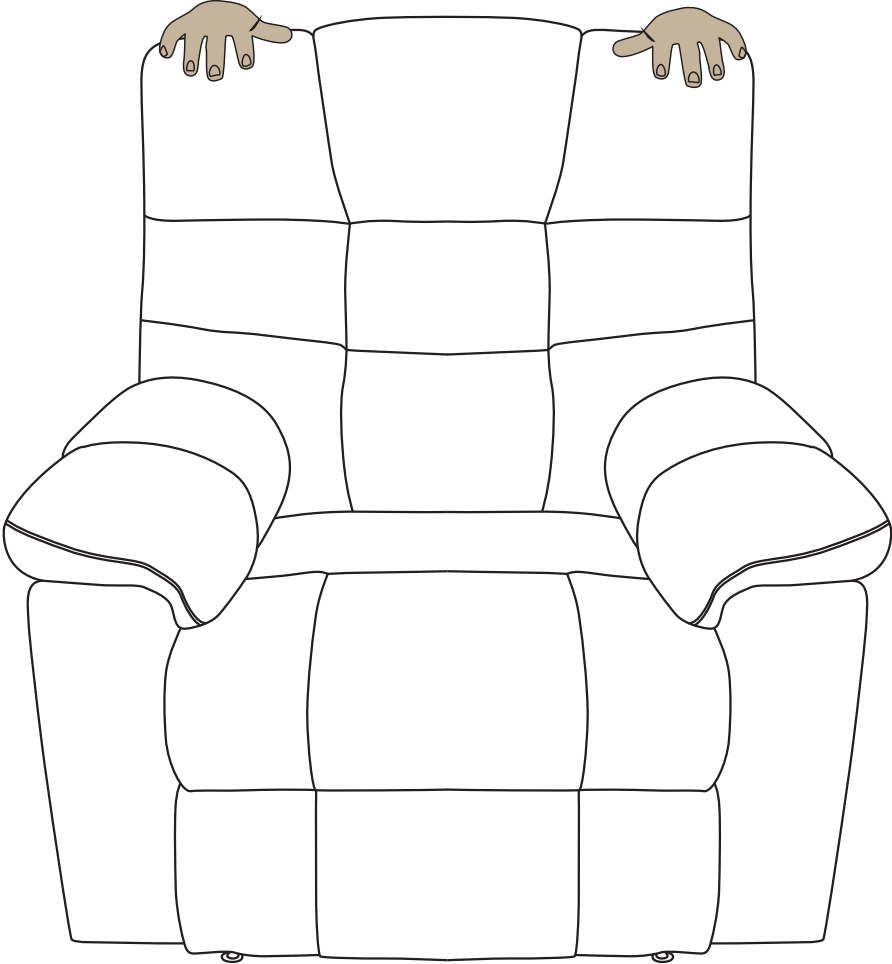

Step7

You can find the hidden cup holder and storage design under the armrest.

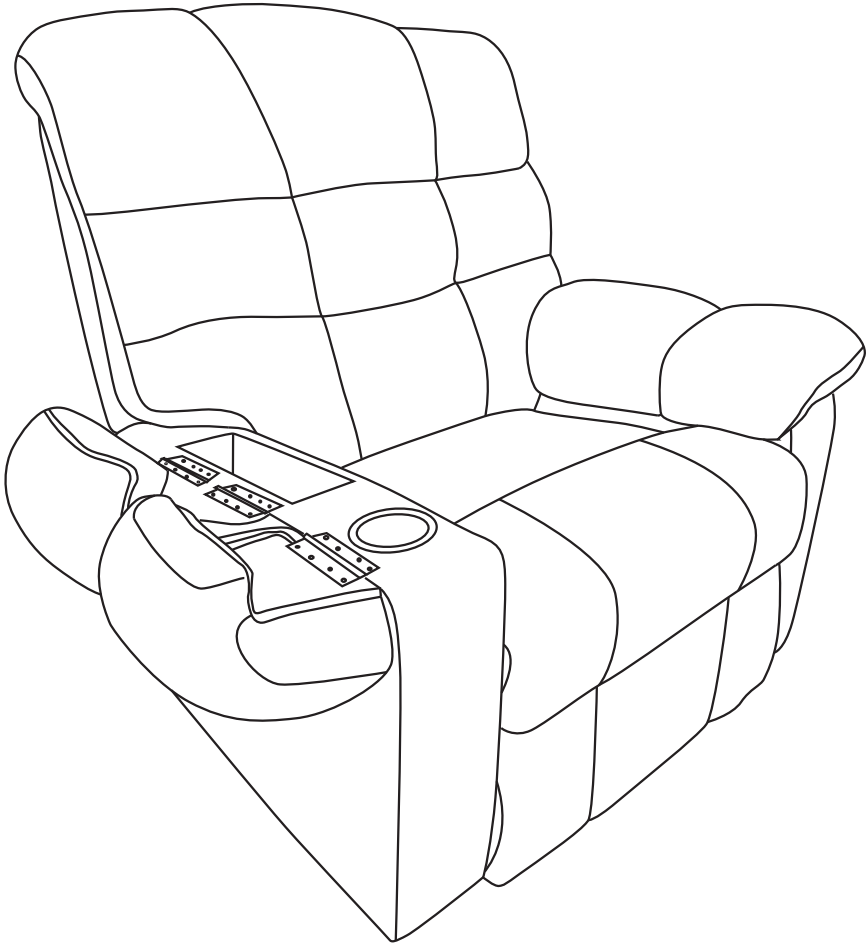

Instructions for Connecting Power Cords

Pls be sure the wires with the same color are connected.

Tip: Lines of the same color must be connected. If the wires with different colors are connected, it can not work.

No.1 and No.2 wires connect the backrest to the chair seat.

No.3 wire connects the backrest to the power plug (F).

No.4 wire connects to the backrest and massage remote(G).

No.5 wire connects the motor with the wire tied in iron frame,which has a control panel.

No.6 connect the power supply(E) to the interface from the botlom of thechair.

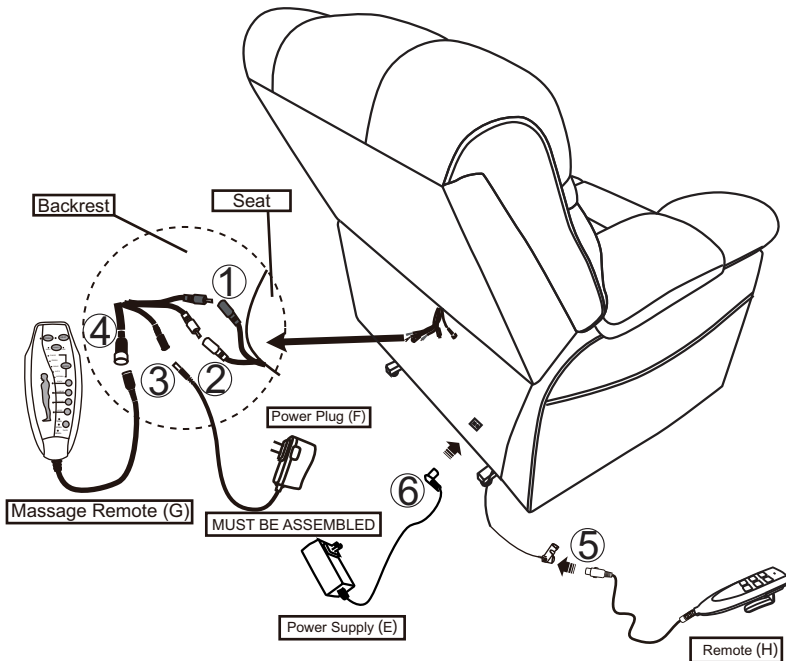

Note:

1.Plug the Power Cord and Power Source into the outlet to get the recliner working.

Instruction for Remote control

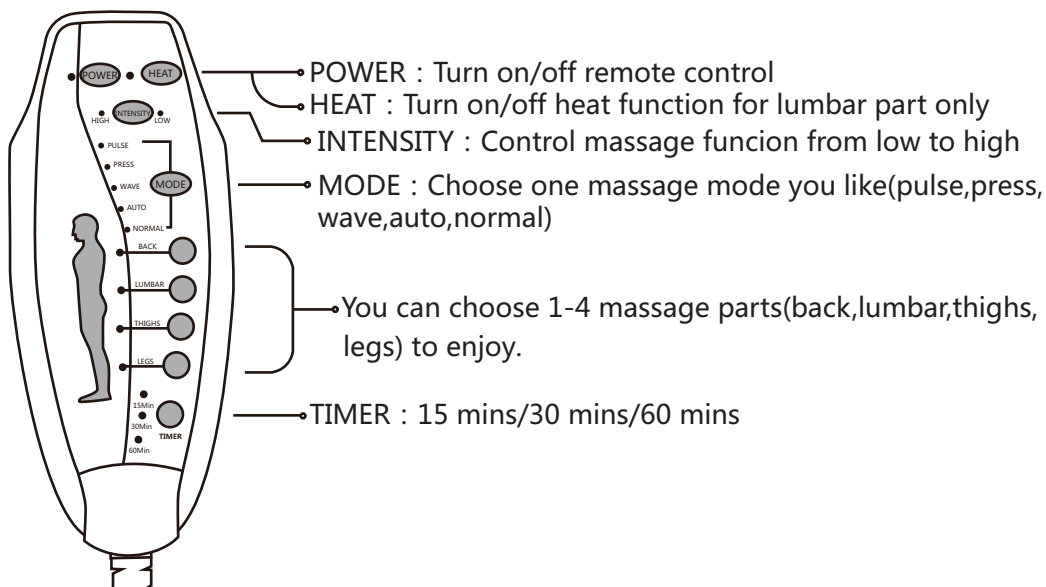

There are 6 buttons in the remote control.

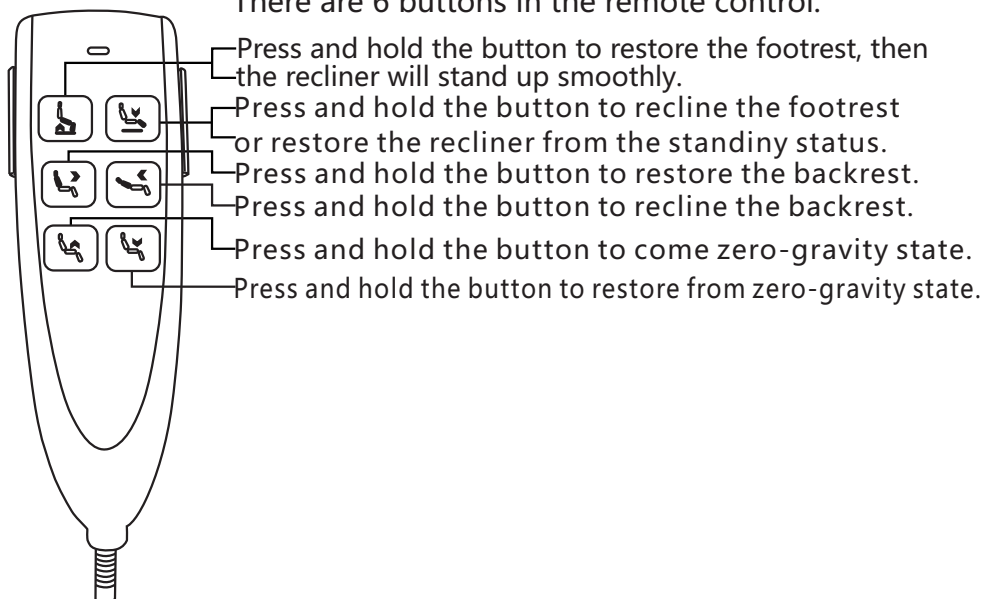

Warnings

1. Please check if the chair's components are all included and can be used generally as the 6th tip.
2. Follow instructions and assemble all components correctly before connecting the chair with the power.
3. Please DO NOT sit on the armrests or footrest to eliminate the risk of tipping over.
4. Please be careful when lifting to avoid sliding from the chair.
5. If the chair you received is damaged or doesn't with the website, please send clear pictures of the product, and take a picture of one side of every outer box. (This side is printed with a camera pattern). Then send us these photos or videos, and we'll help you to solve all problems.
6. If the recliner doesn't work, you can try the following measures for self-checking:
 - ① Check if all the cables are connected;
 - ② Check if the pilot lamp of remote control is on or off;
 - ③ Check if the pilot lamp of the power supply is on or off
(1. on is normal. 2. off, check the wire connection of power supply, if connection is correct but the light is not on, please contact us to change a new power supply for you.)
 - ④ If the motor has a weak buzz on the condition that the two steps above are normal. If the chair still doesn't work, please leave the message to customer service in time. We will help solve the problem for you as soon as possible.
7. If you have any questions about the product, please get in touch with us.

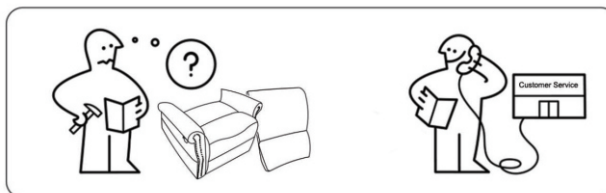
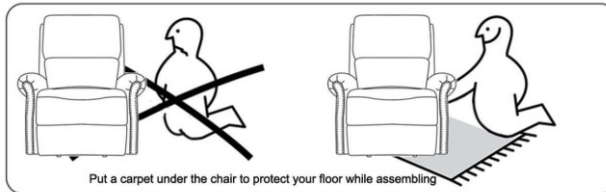

HEALTH CAUTION

- ☒ If you have any concerns regarding to your health, consult your doctor before using this product.
- ☒ Individuals with pacemakers should not use this product.
- ☒ If you have pain in a muscle or joint after using for a prolonged period of time, discontinue using and consult your doctor. Persist pain could be a symptom of a more serious condition.

MAINTAINANCE INSTRUCTIONS

TO STORE:

Place unit in its box or safety dry and cool place. Avoid putting chair in contact with sharp edges or pointed objects which might cut or puncture the fabric. Do not wrap attached power cord around the unit. DO NOT pull the unit by power cord.

TO CLEAN:

- ☒ Ensure the unit is unplugged from the power source, and allow the unit to cool down before cleaning.
- ☒ DO not use any liquid to clean. Clean fabric cover by wiping with a damp sponge, using a mild detergent or suds. Pat with clean, dry cloth.
- ☒ Do not use any abrasive cleaners, brushes, gasoline, kerosene, glass furniture polish, paint thinner or water hotter than 120° F to clean the unit.