

ASSEMBLY INSTRUCTIONS

483-701/483-B01

TOOLS REQUIRED:





Allen Wrench (supplied, part # D)

BEFORE YOU START:

1. Check the parts against the parts list to make sure all items are present.
2. Assemble your furniture on a soft, flat surface to avoid scratching the finish.
3. CAUTION: Do not over tighten screws, nuts or bolts during assembly.
4. Your furniture may require occasional tightening.

INSTRUCTIONS:

1. Turn the table top on the smooth and clean soft surface.
2. Attach table base ① to top ② using Bolt (A), Lock Washer (B), Flat Washer (C) and tighten with Allen Wrench (D). As shown in Figure 1.
3. Adjust the leveler at bottom if necessary. As shown in Figure 2.

NO	DRAWING	DESCRIPTION	SIZE	Q'ty
A		Bolt	5/16"x1-1/2"	4pcs
B		Lock washer	Ø5/16"	4pcs
C		Flat washer	Ø5/16"x3/4"	4pcs
D		Allen Wrench	100*50*4mm	1pc

Warning

Locate furniture case close to its final location before installing feet/ legs. After installation of feet/ legs use two people to lift the case to its upright position with the provided hand hold cut-outs in the back of the case.

NOTE:USE CAUTION WHEN MOVING FURNITURE ON UNEVEN FLOORS!

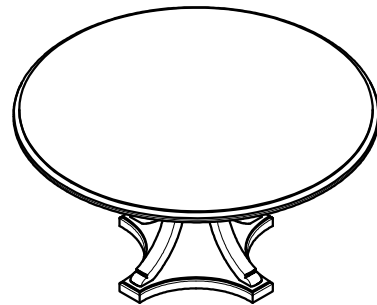

Figure 1

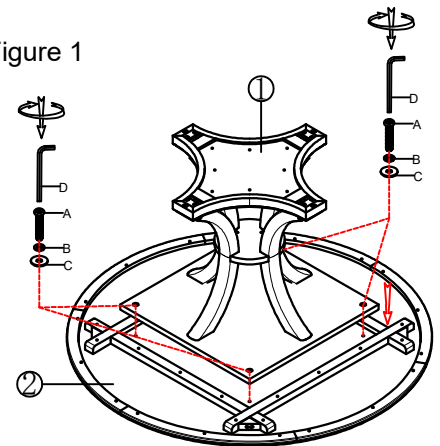

Figure 2

