

- PL** Instrukcja montażu
- CZ** Návod k montáži
- D** Montageanleitung
- GB** Assembly instruction
- F** Model d'emploi
- HU** Szerelési útmutató
- I** Istruzione di montaggio
- NL** Handleiding voor de montage
- RU** Инструкция по монтажу
- RO** Instrucțiuni de montare
- SK** Návod k montáži
- TR** Montaj talimatı

Uwaga • Upozornění • Achtung • Attention • Caution • Figyelem Attenzione • Opgelet • Внимание • Atenție • Upozornenie • Dikkat	
PL	Czyszczenie należy wykonać wyłącznie za pomocą ściereczki lub lekko nawilżonego ręcznika. Nie stosować środków czyszczących do szorowania.
CZ	Čistění je nutné vykonávat výhradně pomocí utěrky nebo lehce navlhčeného ručníku. Nepoužívejte čističí prostředky obsahující abrazivní částice.
D	Bitte nur mit einem Staubtuch oder leicht feuchtem Lappen reinigen. Keine scheuernden Putzmittel verwenden.
GB	Please only clean with a duster or a damp cloth. Do not use any abrasive cleaners.
F	Le nettoyage se fait uniquement à l'aide d'un torchon ou d'une serviette légèrement mouillée.
HU	A tisztítás kizárólag törölruha vagy enyhén nedvesített törölköző segítségével végezhető. Súroló hatású tisztítószerket nem szabad használni.
I	Pulire esclusivamente con un panno o un asciugamano umido.
NL	Reinig alleen met een stofdoek of een lichtjes vochtige doek. Gebruik geen schurende poetsmiddelen.
RU	Очищайте от пыли тряпкой или слегка влажной ветошью. Не допускается применение чистящих средств, не предназначенных для ухода за мебелью.
RO	Curățarea trebuie efectuată numai cu o cârpă sau cu un prosop ușor umezit. Nu utilizați agenți de curățare abrazivi.
SK	Čistení je nutné vykonávať výhradne pomocí utierky alebo ľahko zvlhnutým ručníkom. Nepoužívajte čistiaci prostriedky obsahujúci abrazívni častice.
TR	Lütfen sadece bir toz bezilye veya hafif nemli yumuşak bir bezle siliniz. Aşındırıcı temizlik malzemeleri kullanmayınız.

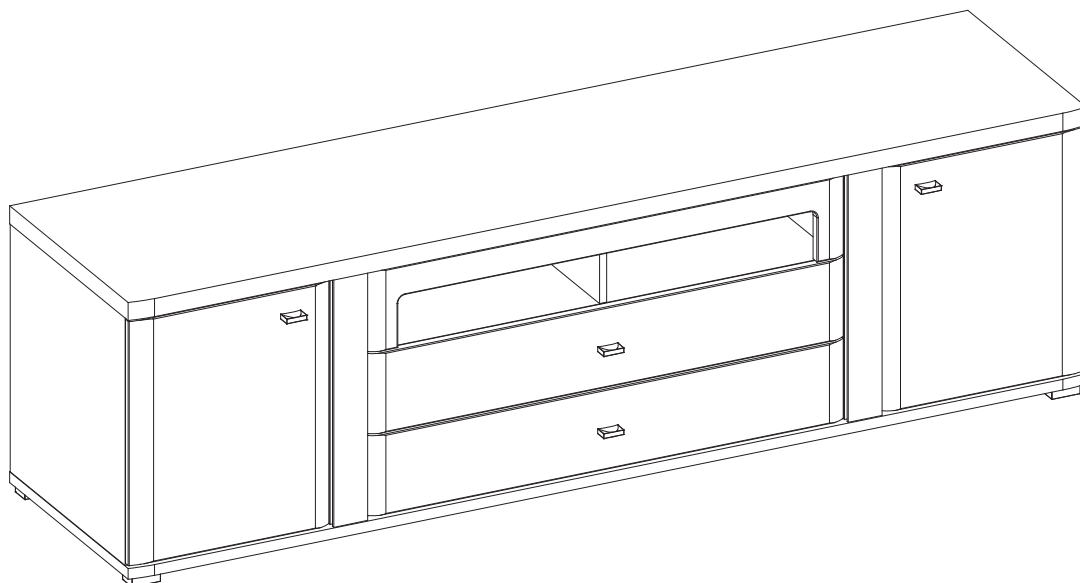

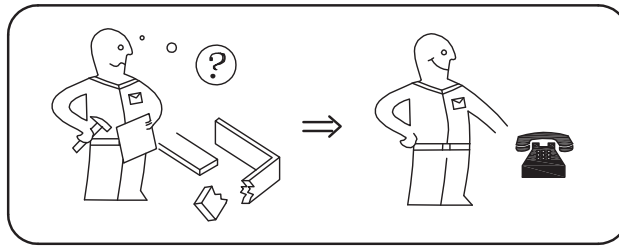

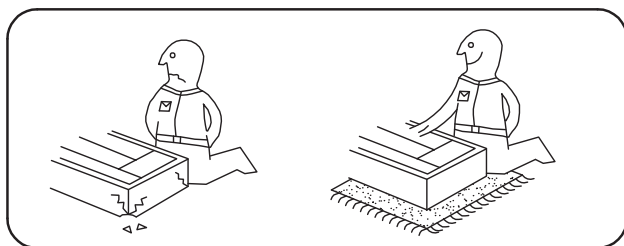
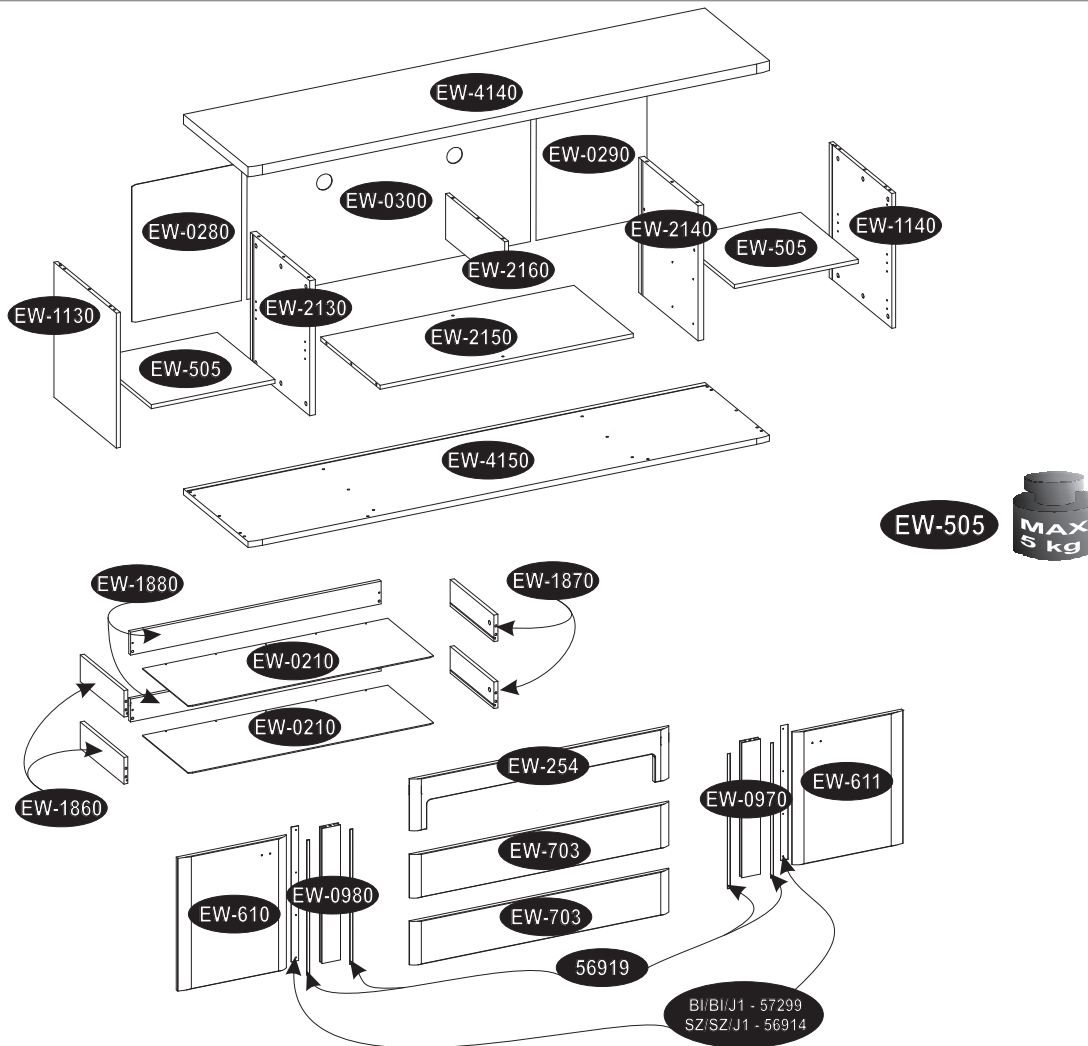
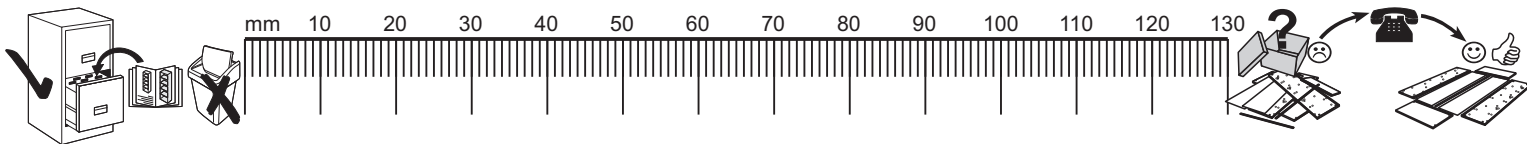

Karta serwisowa • Servisní list • Service Karte • Service card • Carte de service • Szervizkártya
 Scheda di servizio • Service kaart • Сервисная карта • Fisa service • Servisný list • Servis karti



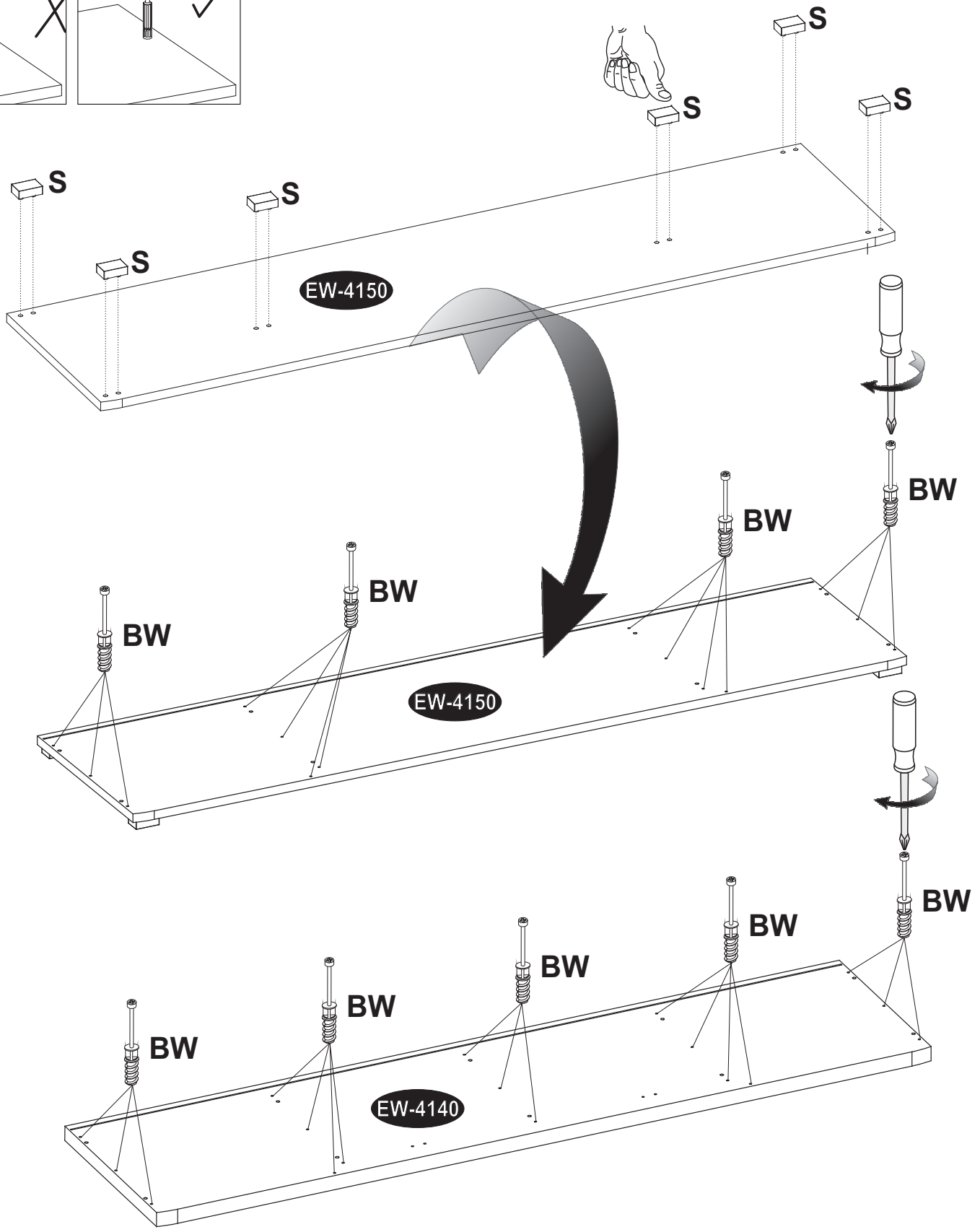
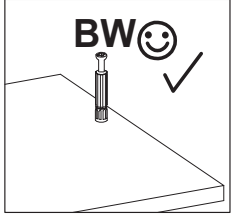
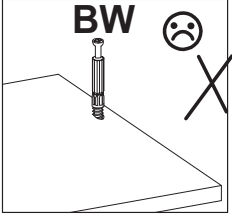
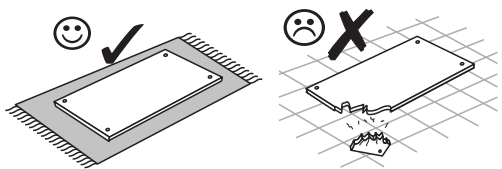
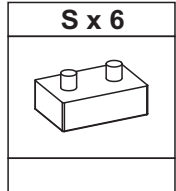
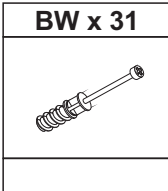



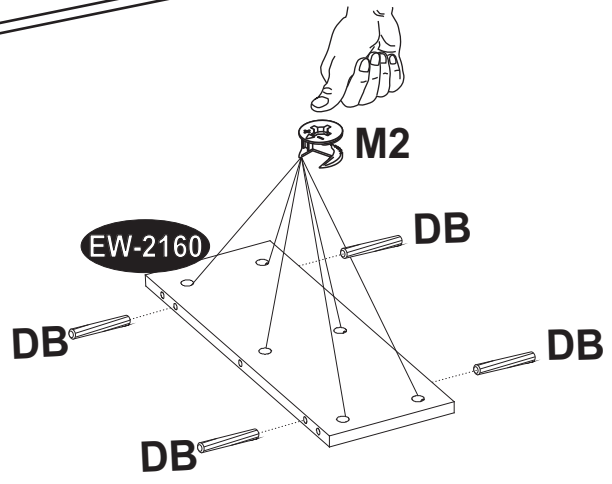
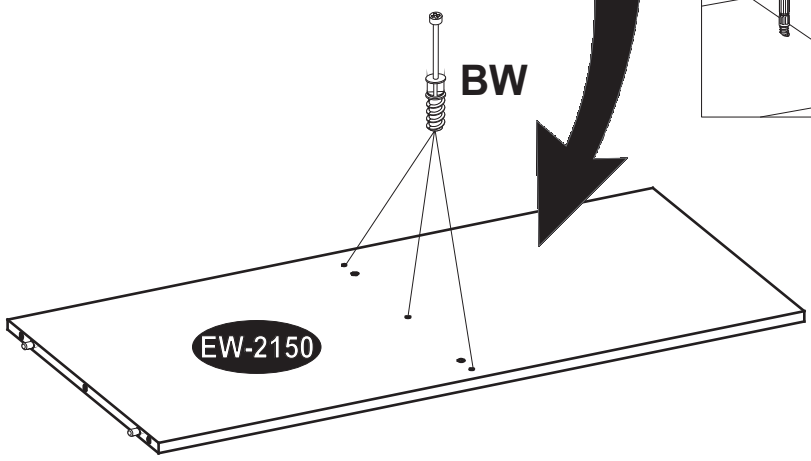
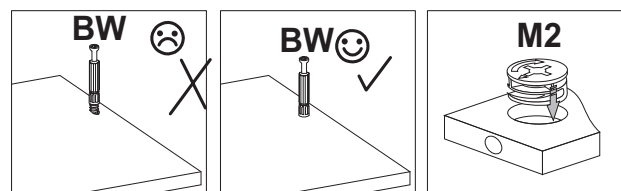
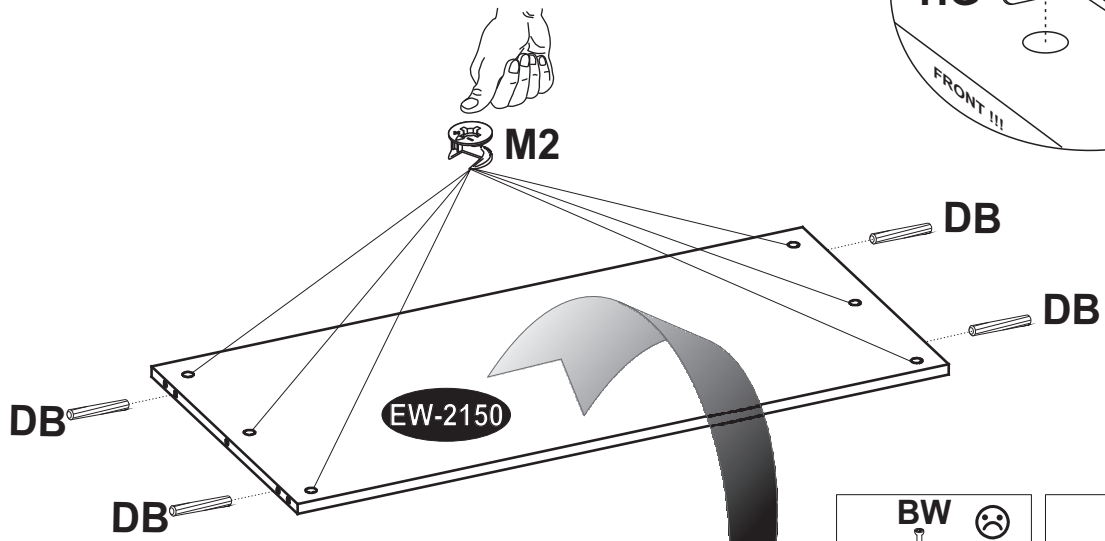
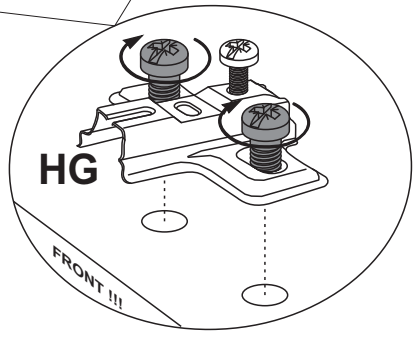
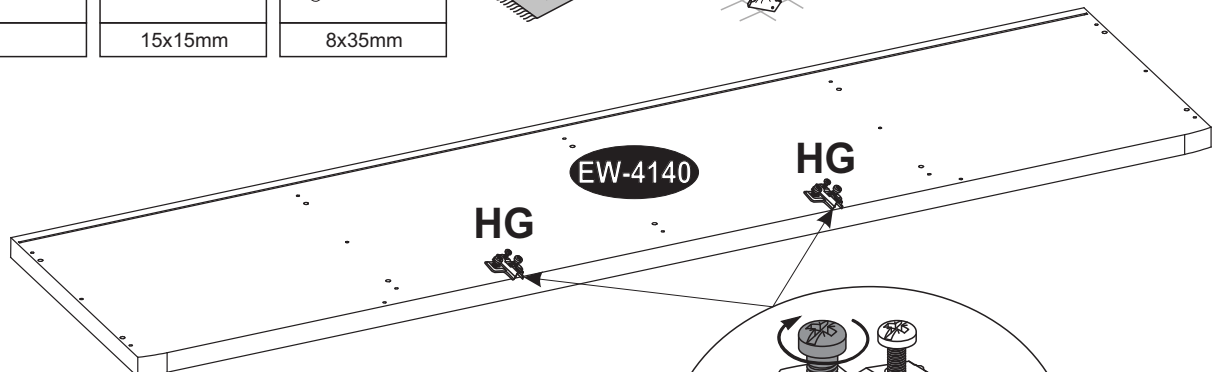
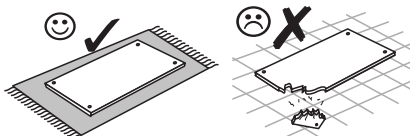

GL x 2 	R12 x 2 8 mm	SC13 x 4 3,5x13mm	SC16 x 17 4x16mm	SC30 x 4 4x30 mm	WS x 2 L-350 mm			
EM x 1 	BW x 44 	M2 x 28 15x15mm	M3 x 4 15x18mm	M4 x 12 15x22mm	DB x 24 8x35mm	PB x 40 20 mm	SW16 x 10 4x16mm	MW25 x 8 M4x25
SWW x 1 	SD2 x 1 	SL x 2 	F x 16 	UCH x 4 	HM0 x 4 110 KR0	HGM x 4 H-4	HM15 x 2 110 KR15	HG x 2 H-2
S x 6 	FVD x 2kpl L-350 mm	BI/BI/J1 - 56920 x 2 SZ/SZ/J1 - 57547 x 2 2,8x5,5x454mm		68196 x 1 	56919 x 4 L-508mm	S16 x 8 5x16mm	SE12 x 8 6,3x12mm	

1

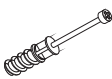

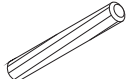

HG x 2	BW x 3	M2 x 12	DB x 8
			
H-2		15x15mm	8x35mm

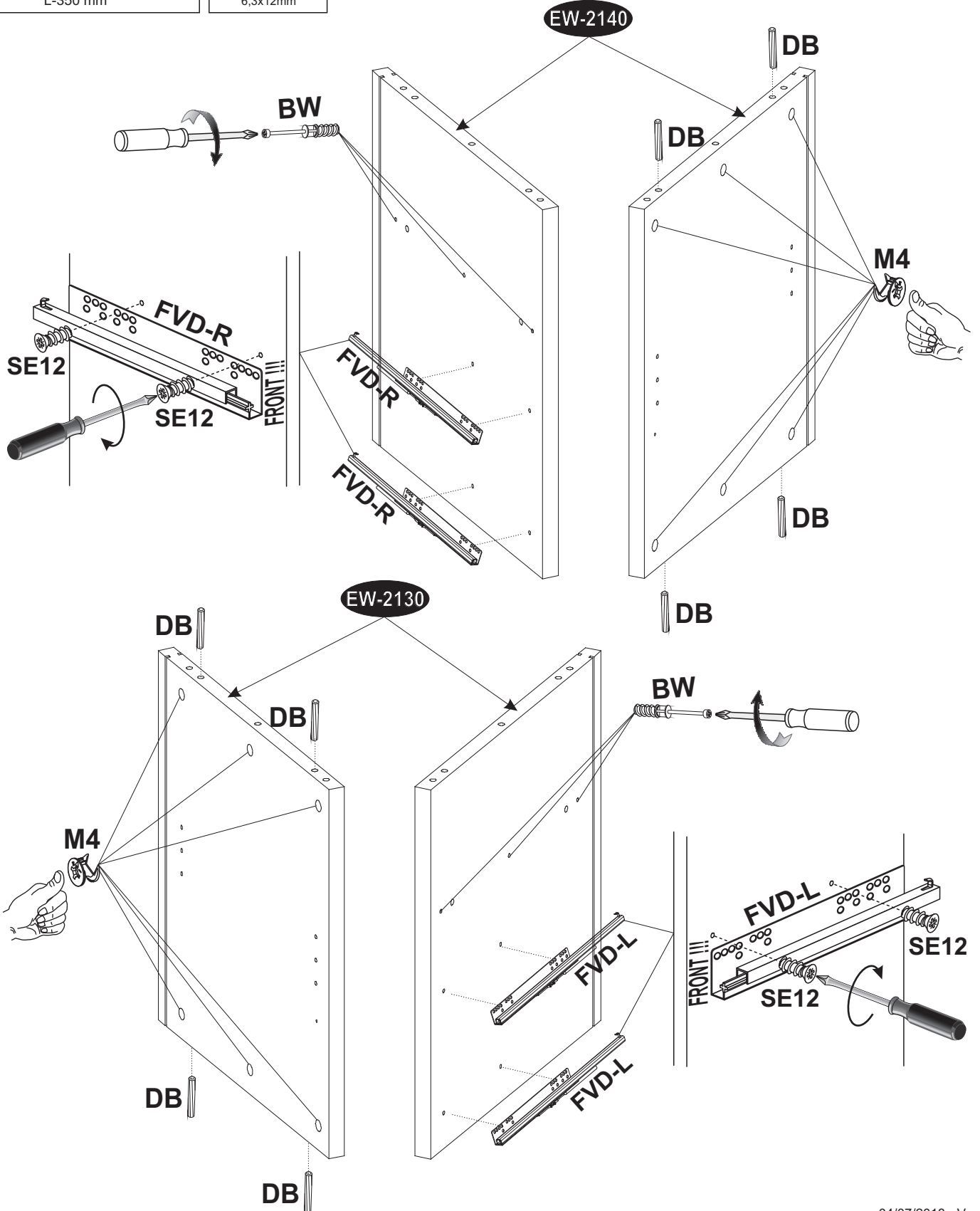
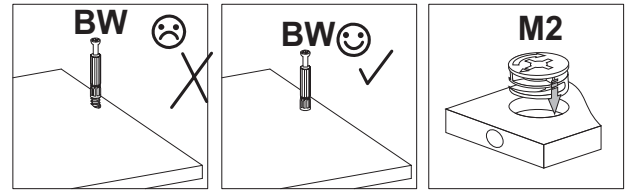
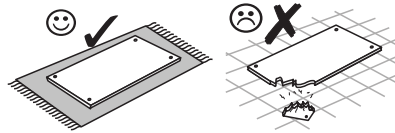

BW x 6 	M4 x 12  15x22mm	DB x 8  8x35mm
FVD x 2kpl L  R  L-350 mm	SE12 x 8  6,3x12mm	



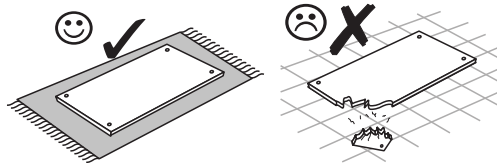

M2 x 12	DB x 8	HGM x 4
		
15x15mm	8x35mm	H-4

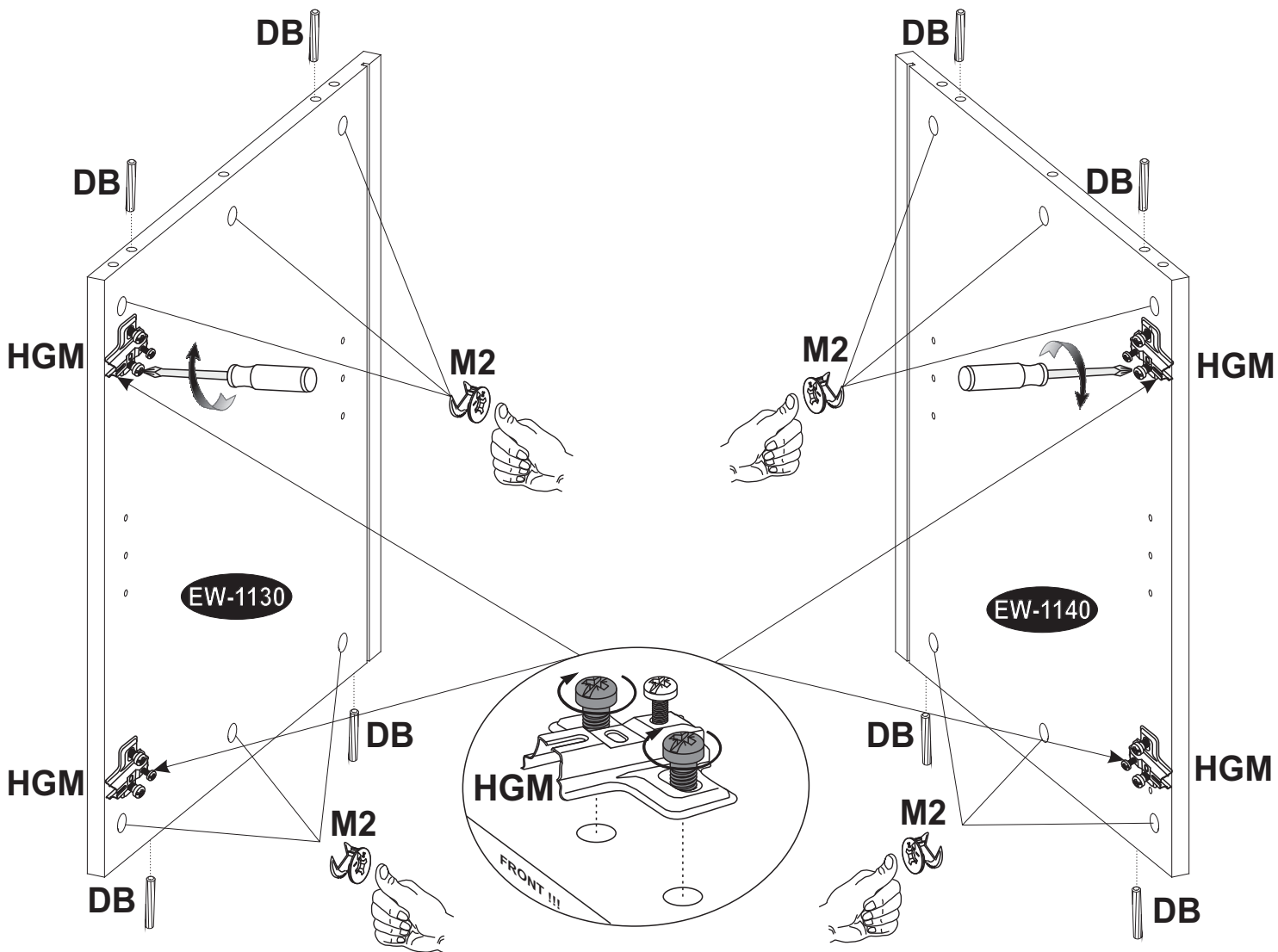
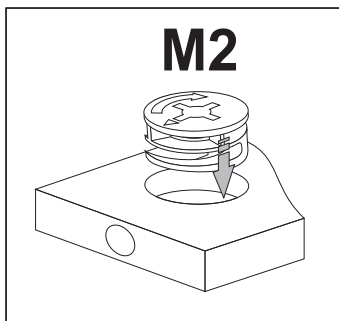

4



M3 x 4	SL x 2	SC16 x 2
		
15x18mm		4x16mm

5

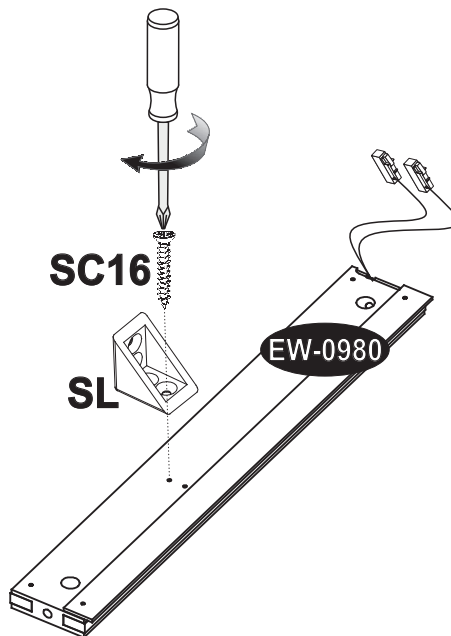
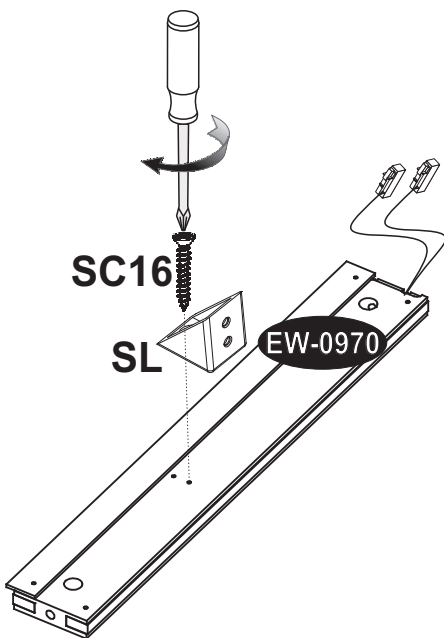
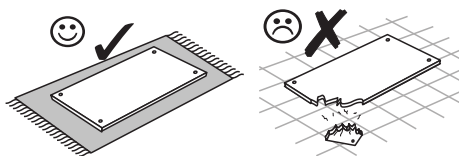

6

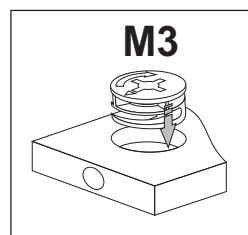
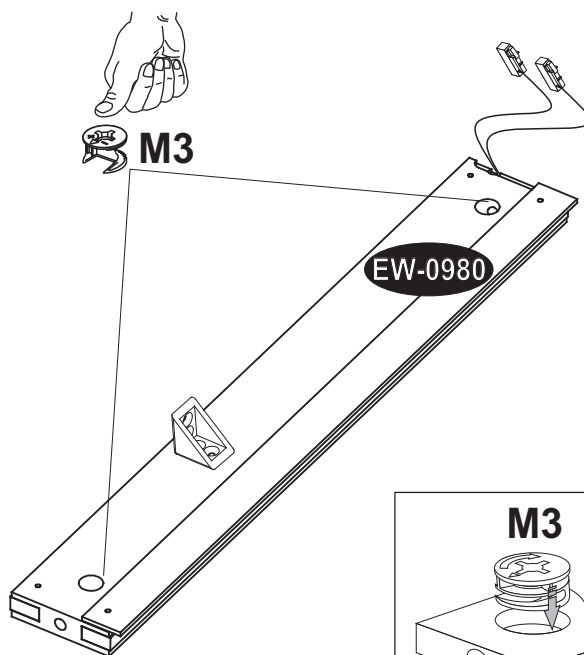
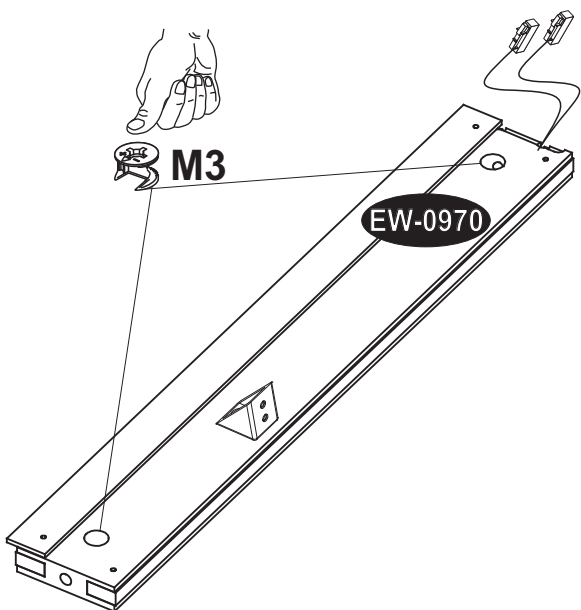

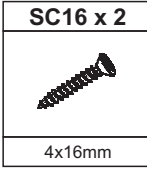

7

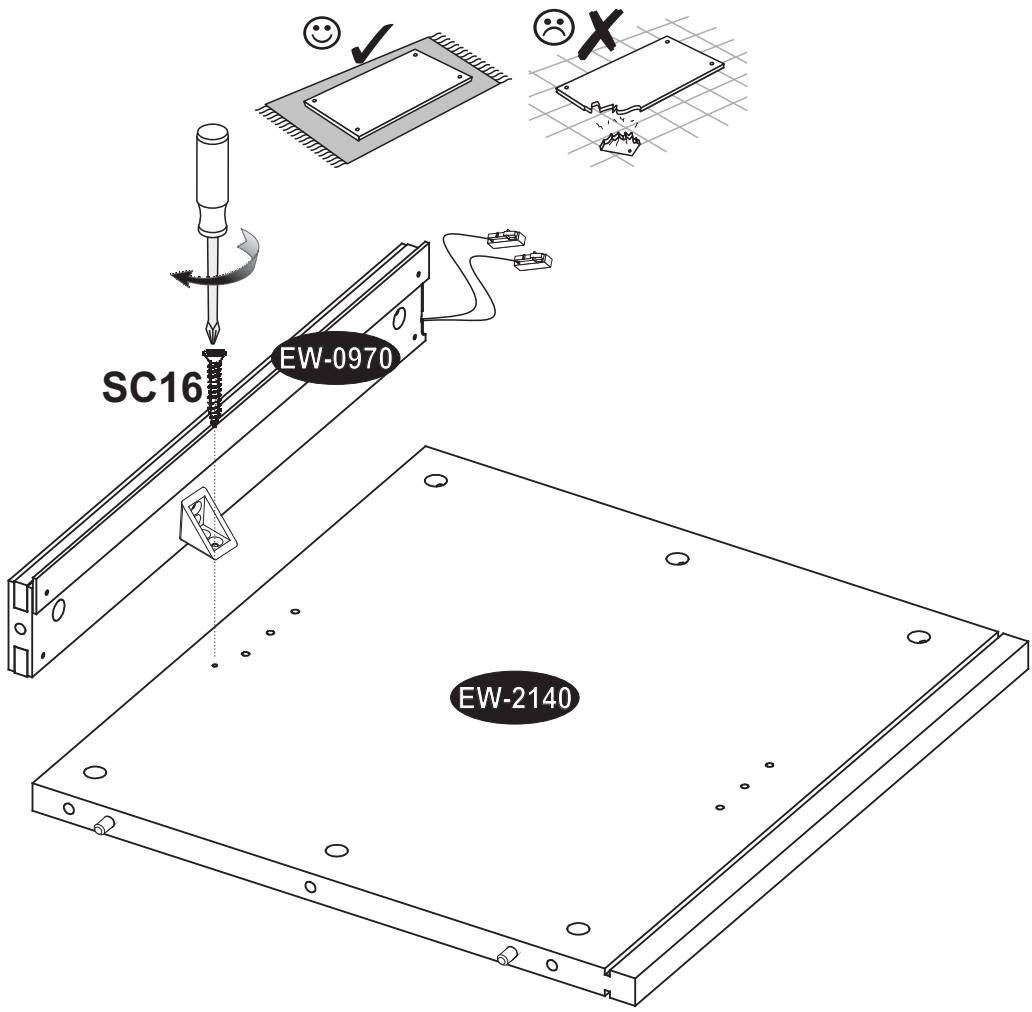

8

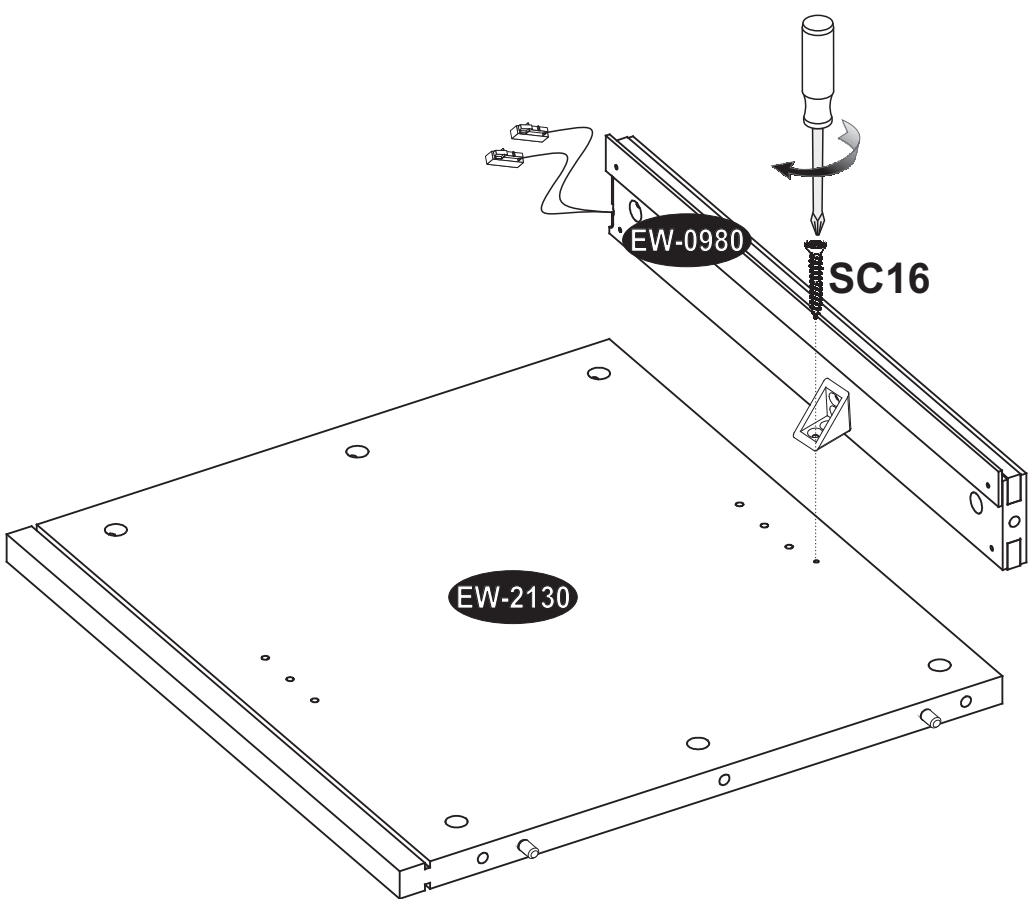

PB x 3
20 mm

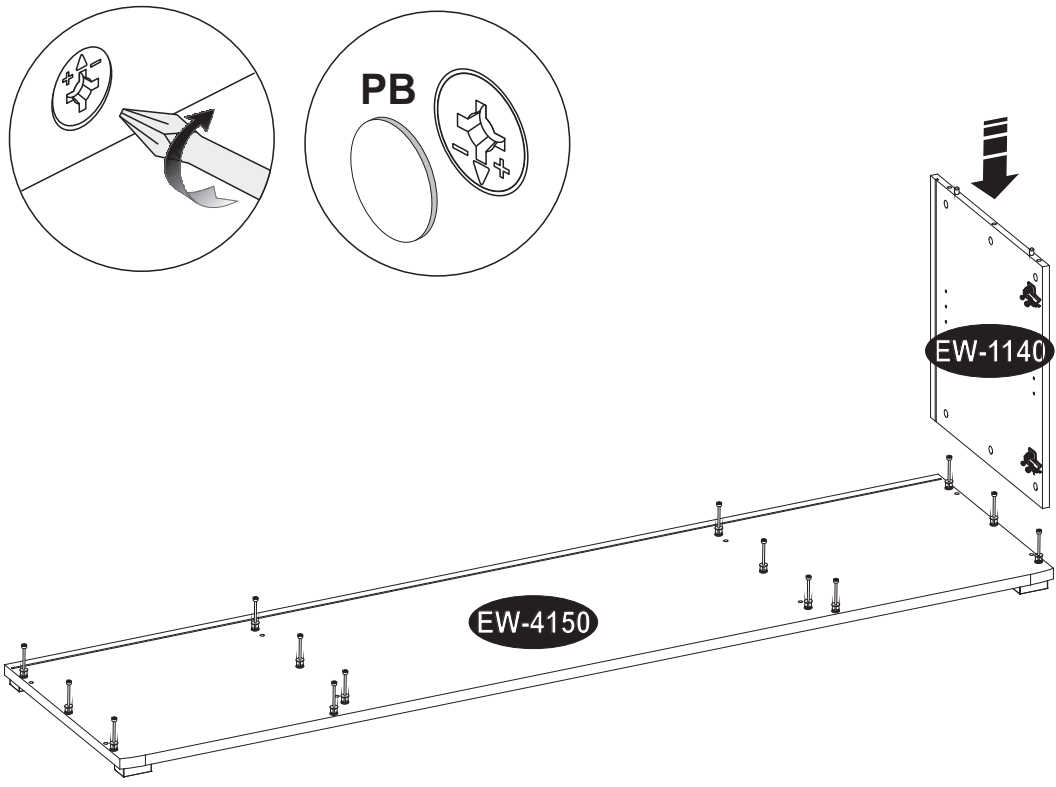

PB x 12
20 mm

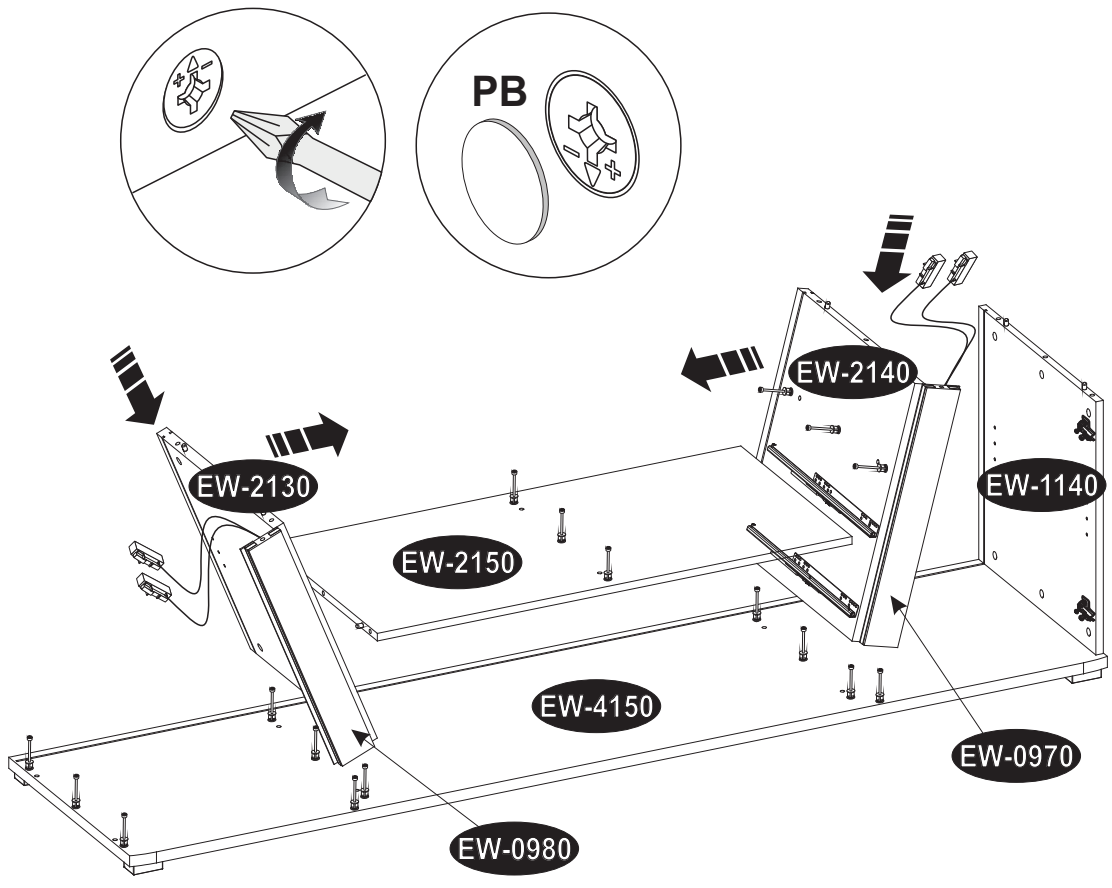

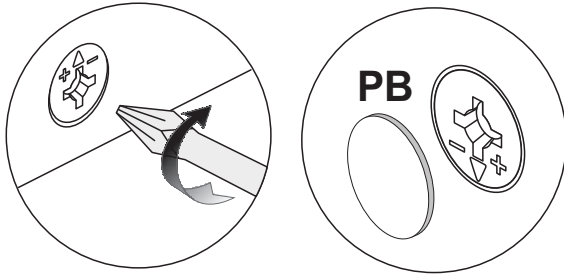
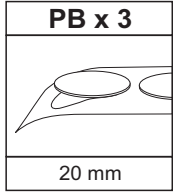

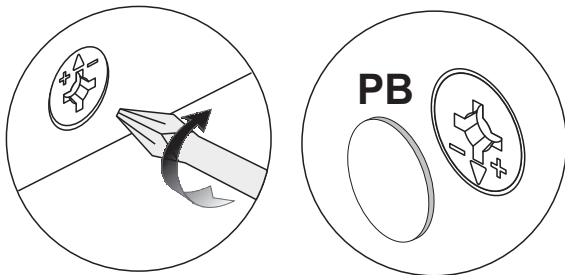
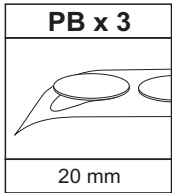
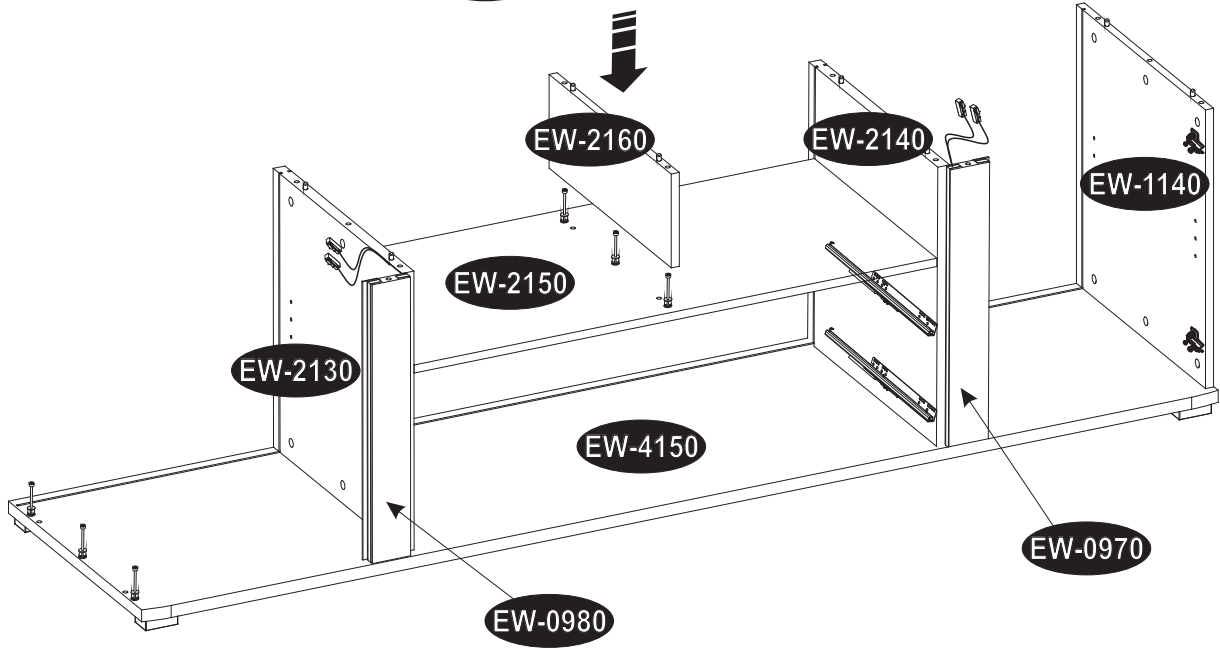

11

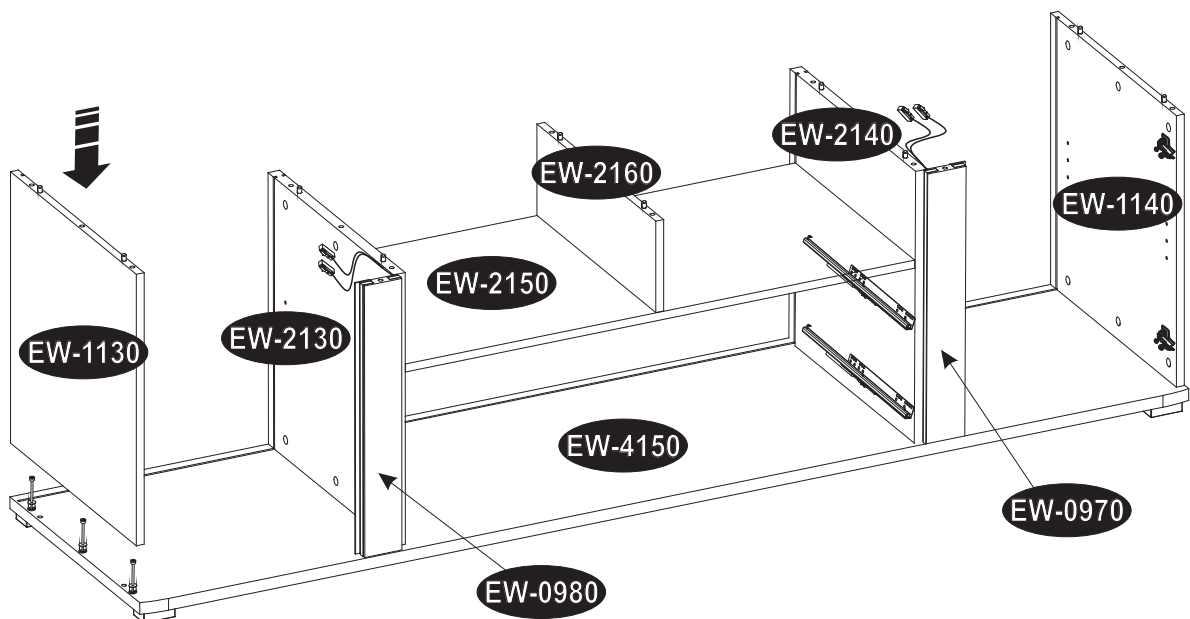

12

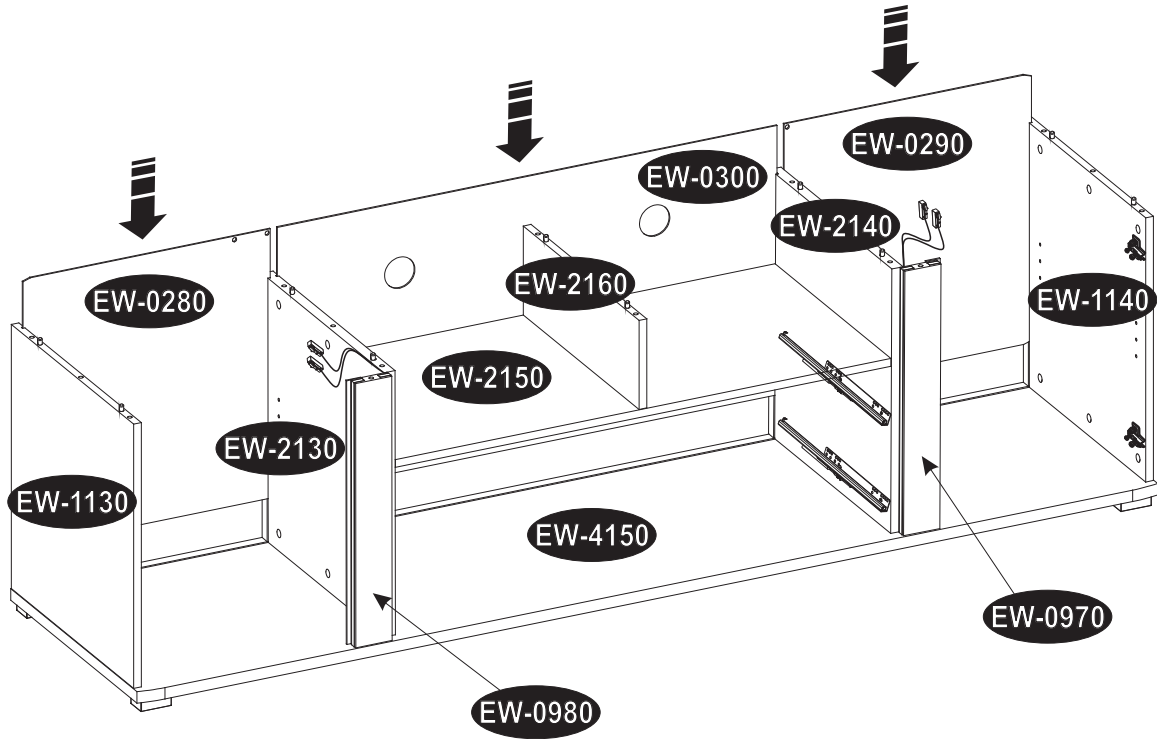

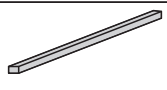

PB x 15	BI/BI/J1 - 56920 x 2 SZ/SZ/J1 - 57547 x 2
	
20 mm	2,8x5,5x454mm

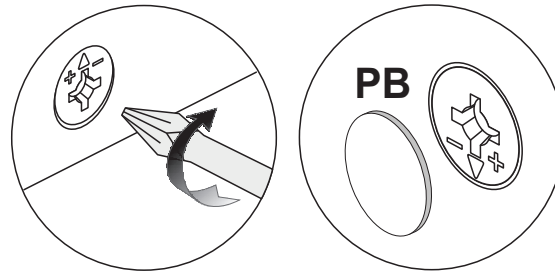
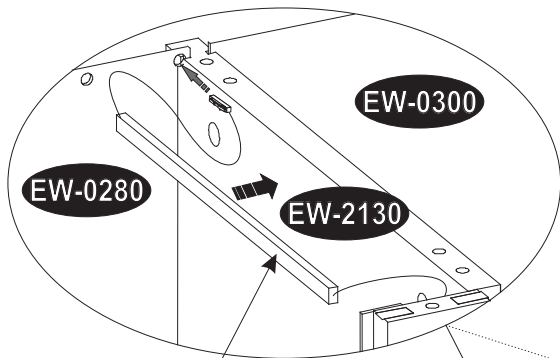

BI/BI/J1 - 56920
SZ/SZ/J1 - 57547

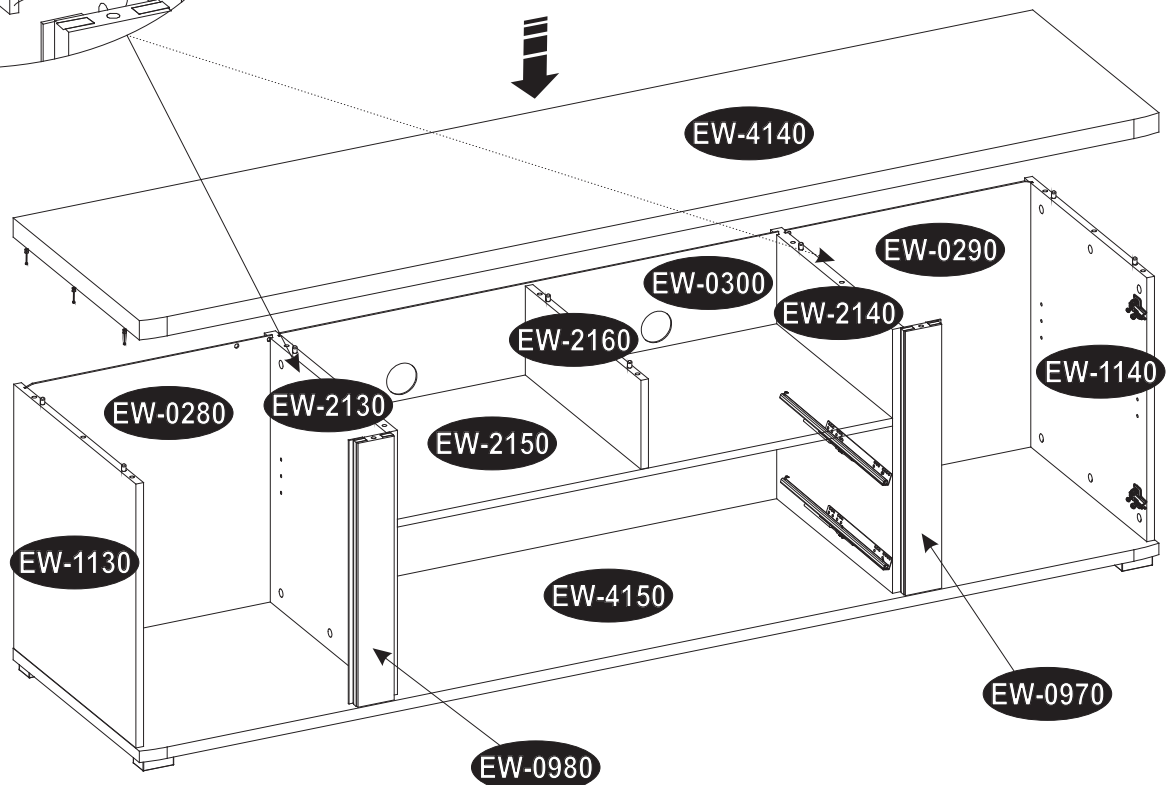

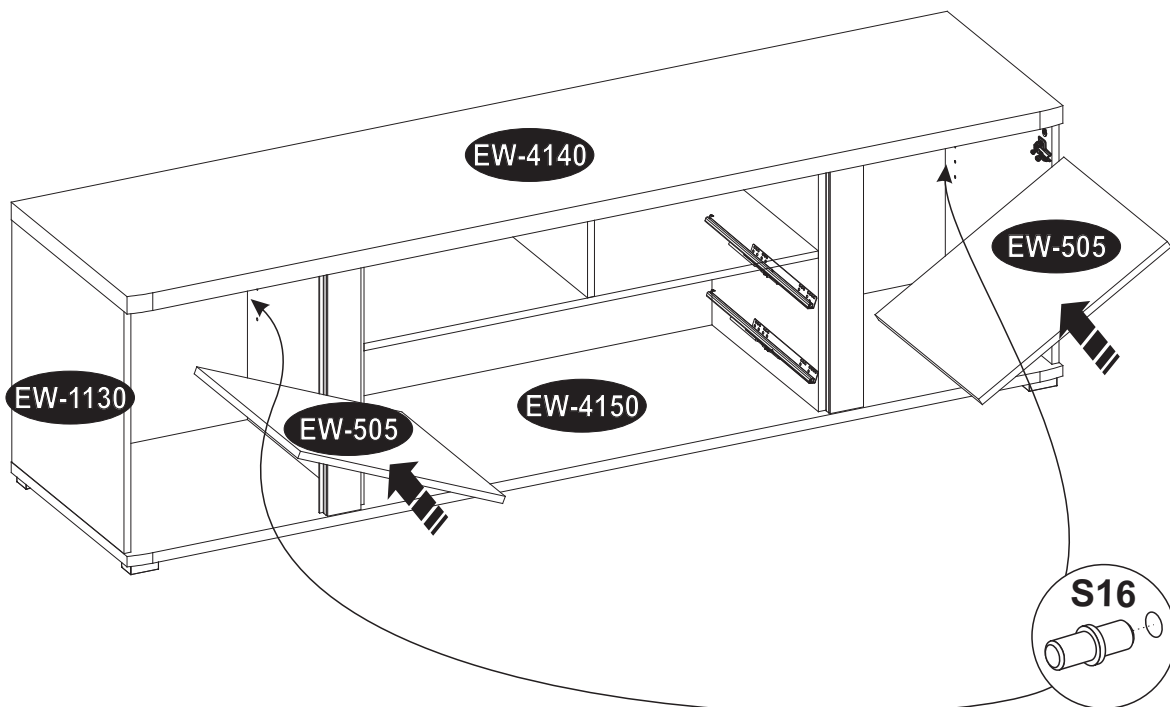
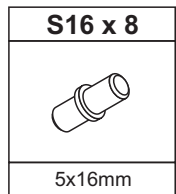
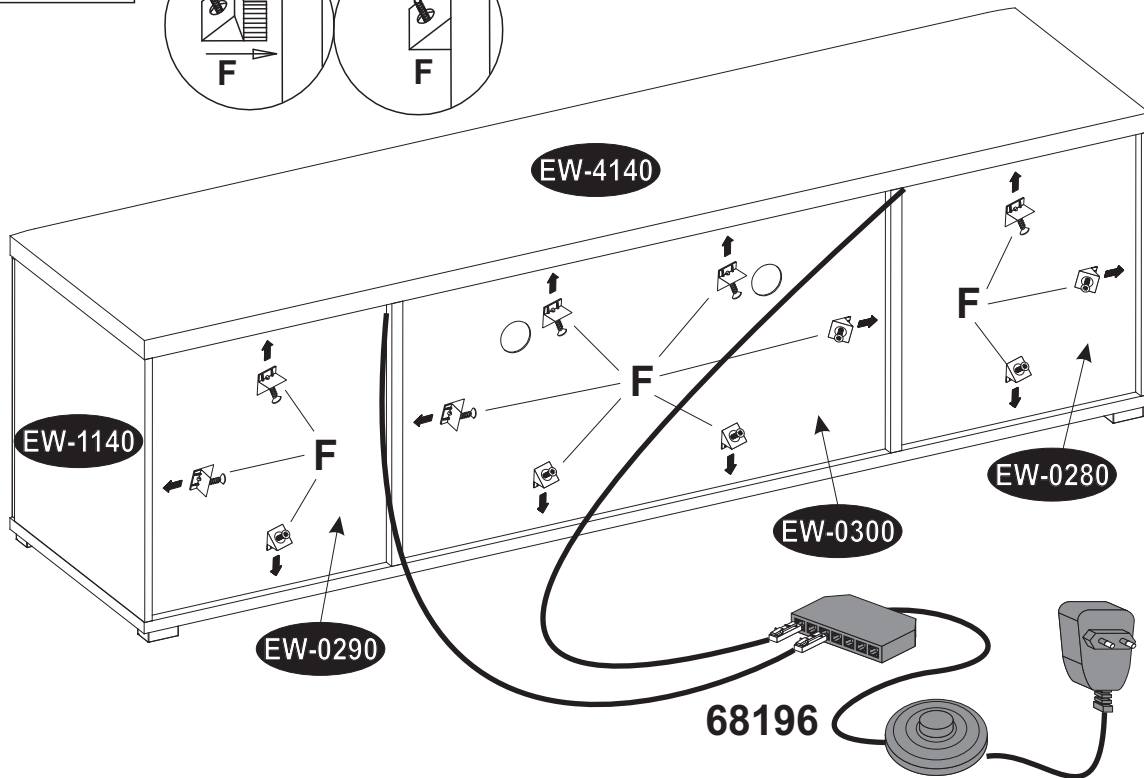
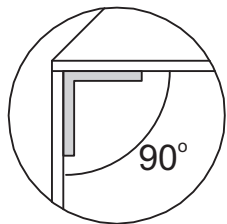
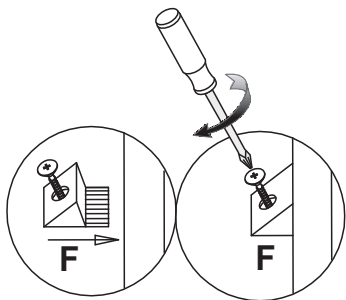
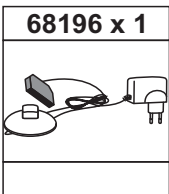
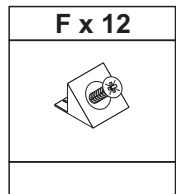

M2 x 4



15x15mm

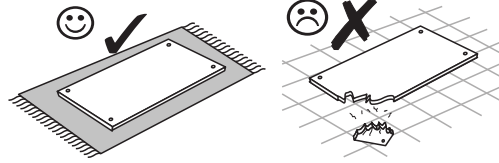

17

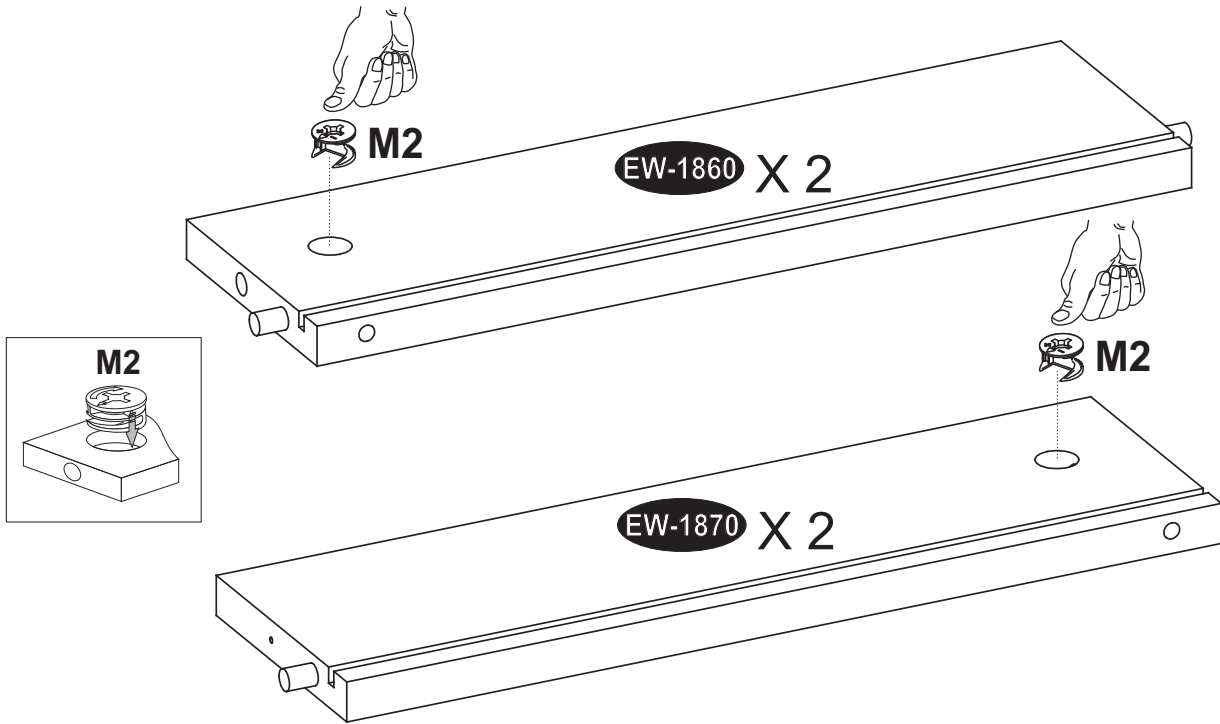



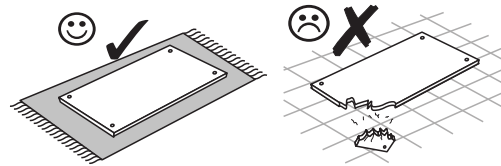
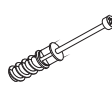

BW x 4

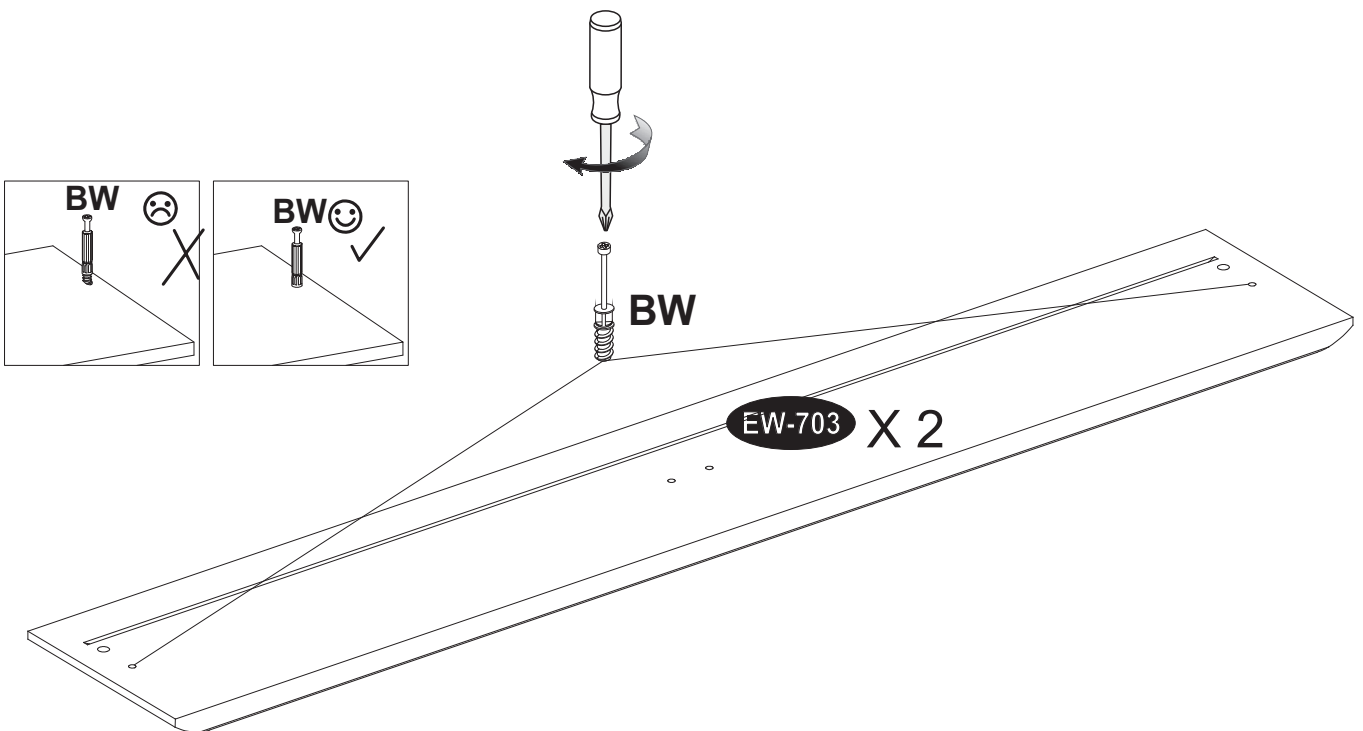





18

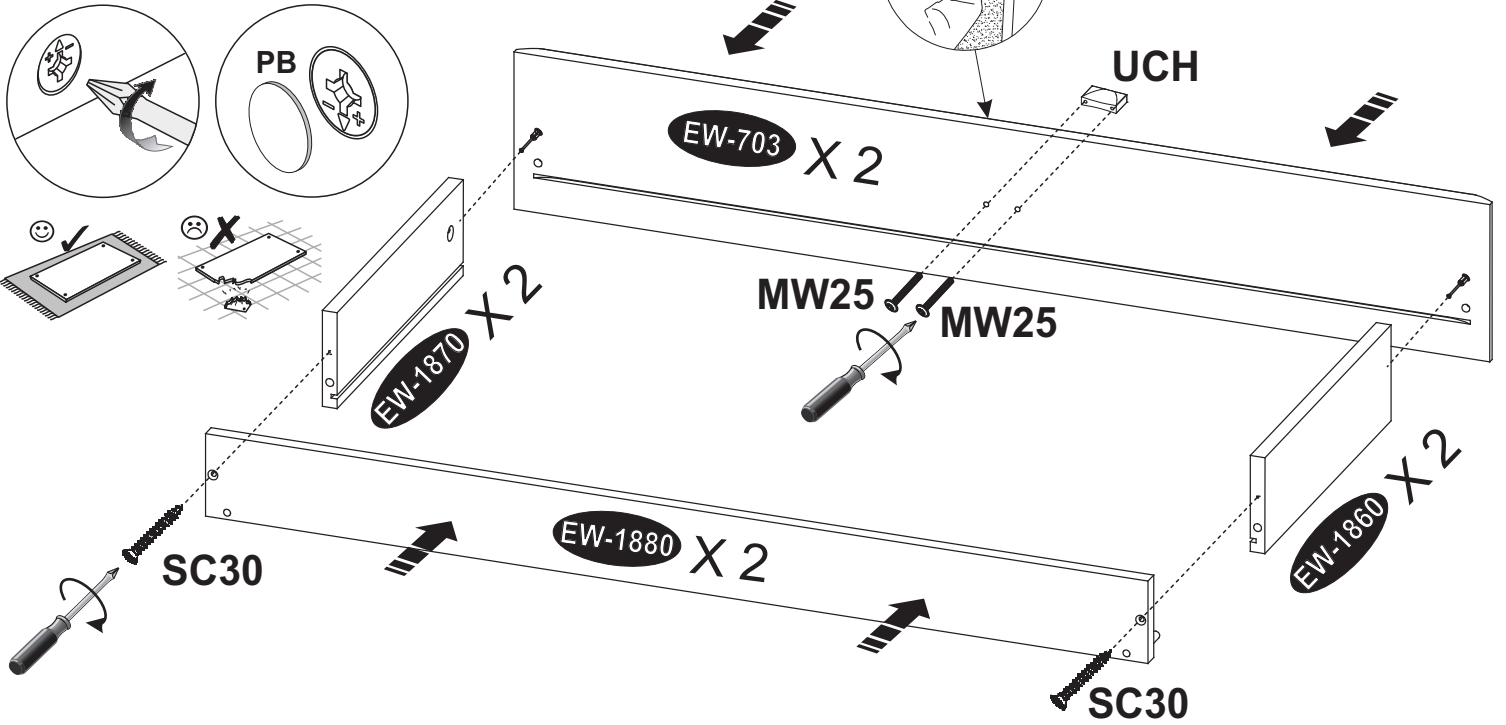

UCH x 2	MW25 x 4	SC30 x 4	PB x 4
			
	M4x25	4x30 mm	20 mm



WS x 2	SC13 x 4
	
L-350 mm	3,5x13mm



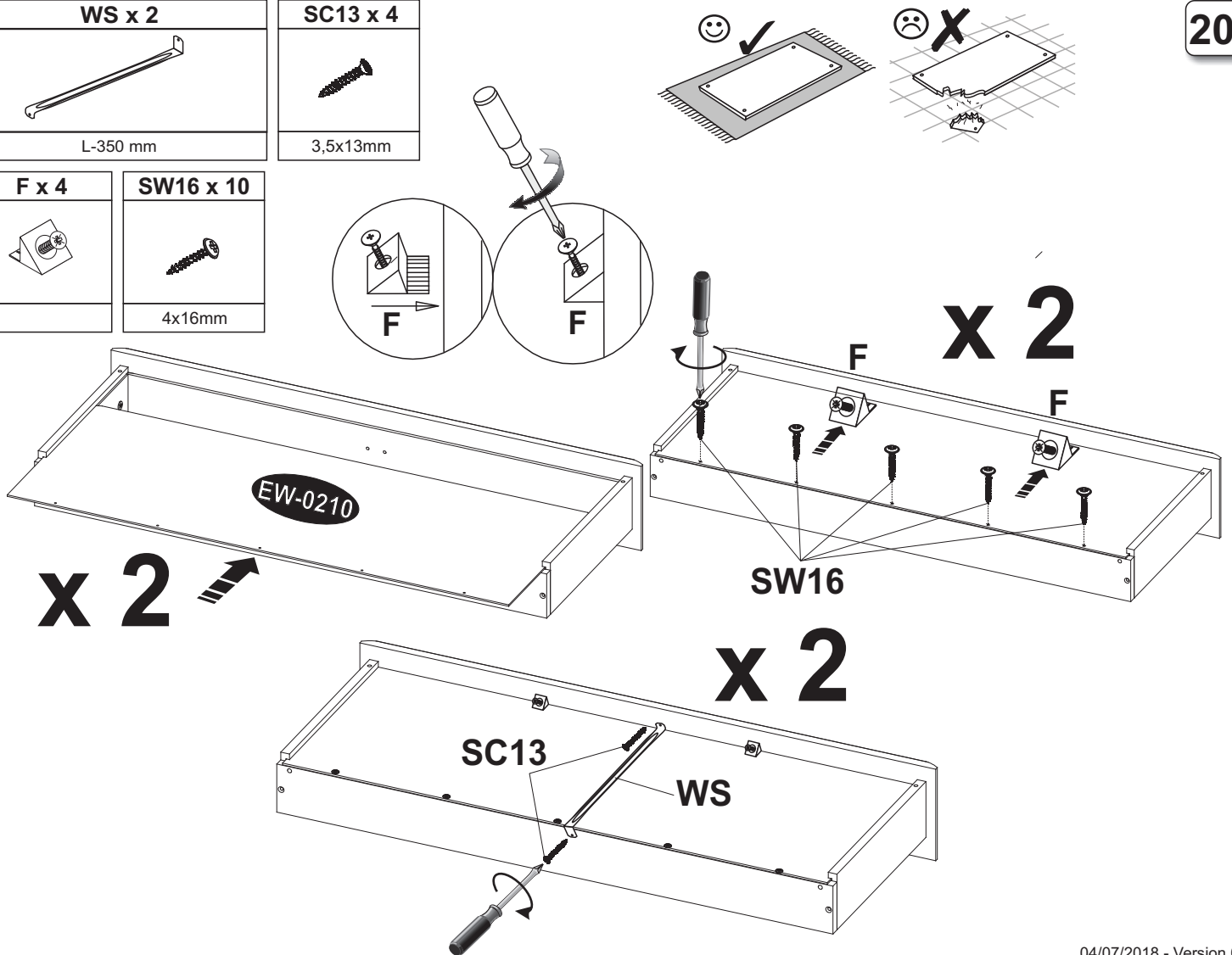

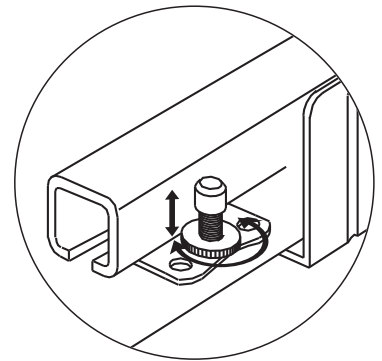
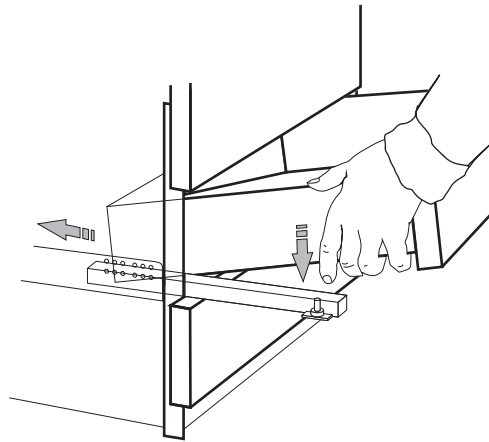
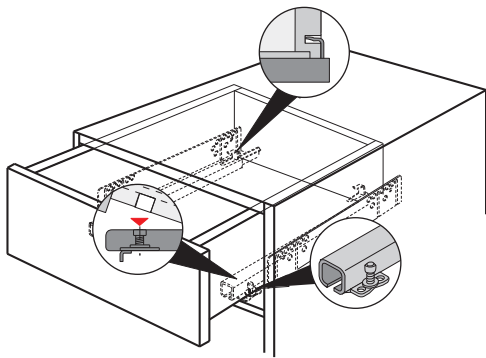
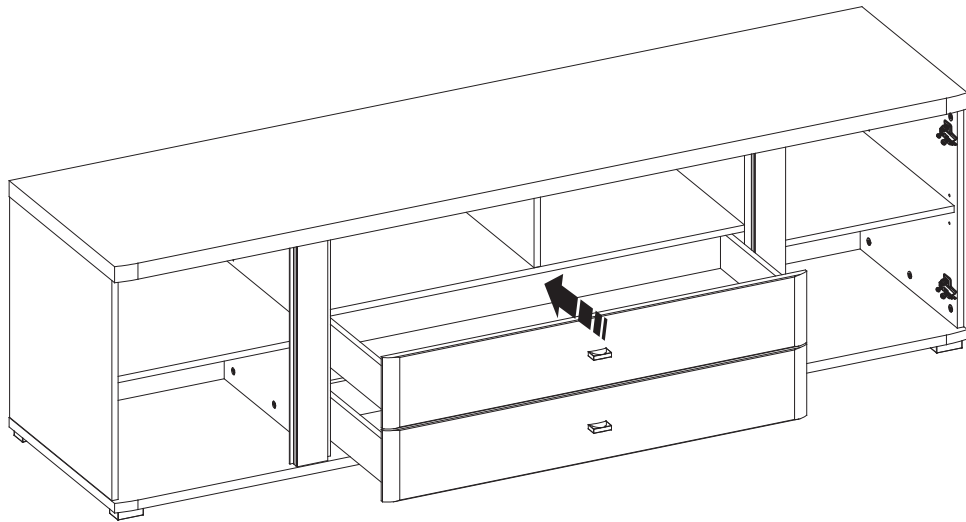
F x 4	SW16 x 10
	
	4x16mm



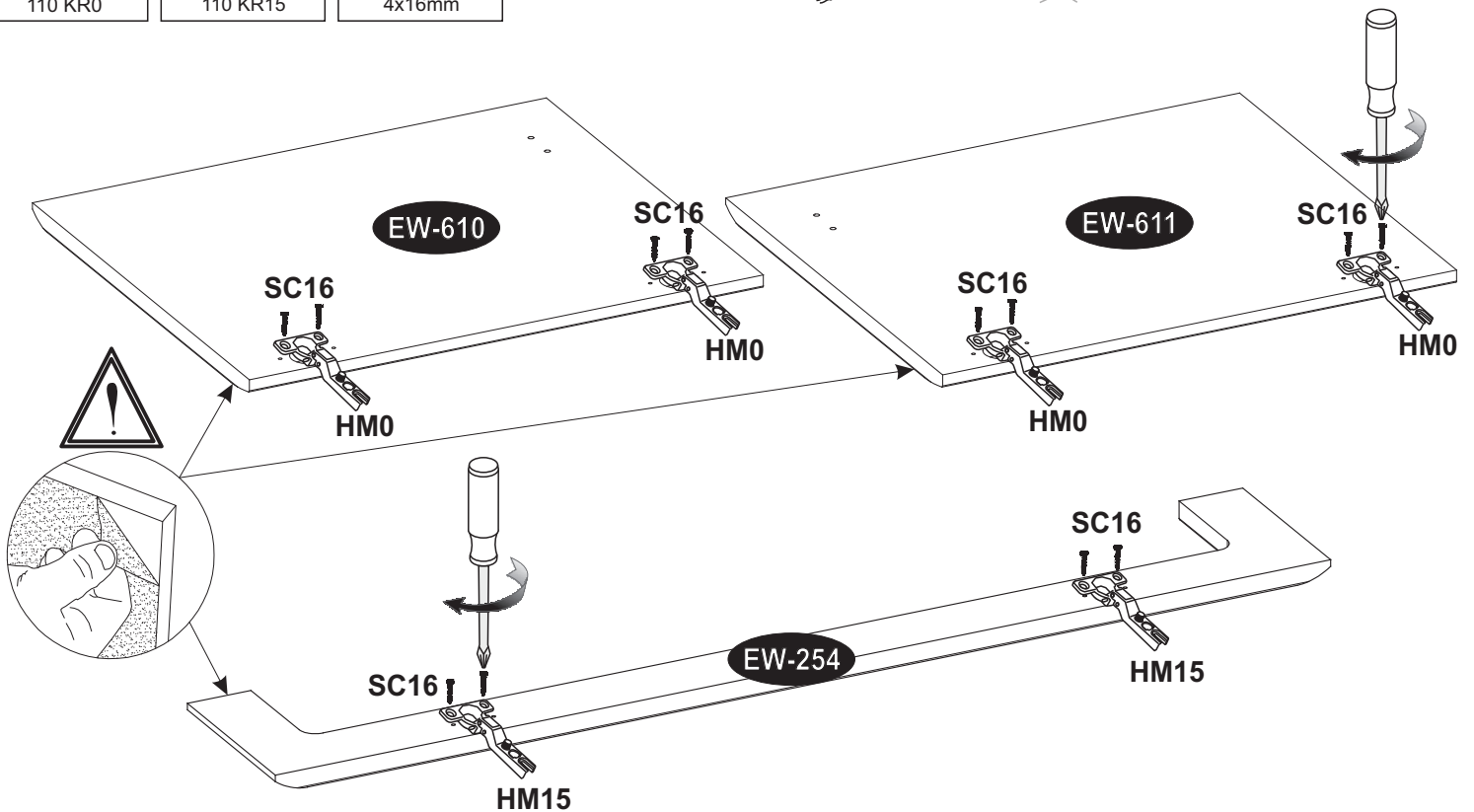
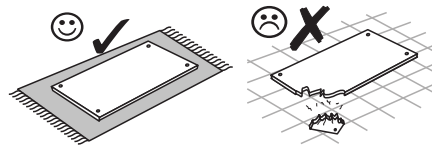

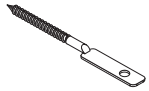

HM0 x 4	HM15 x 2	SC16 x 12
110 KR0	110 KR15	4x16mm



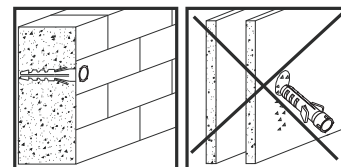

SWW x 1 	SD2 x 1 	SC16 x 1  4x16mm	UCH x 2 	MW25 x 4  M4x25
--	---	--	---	---

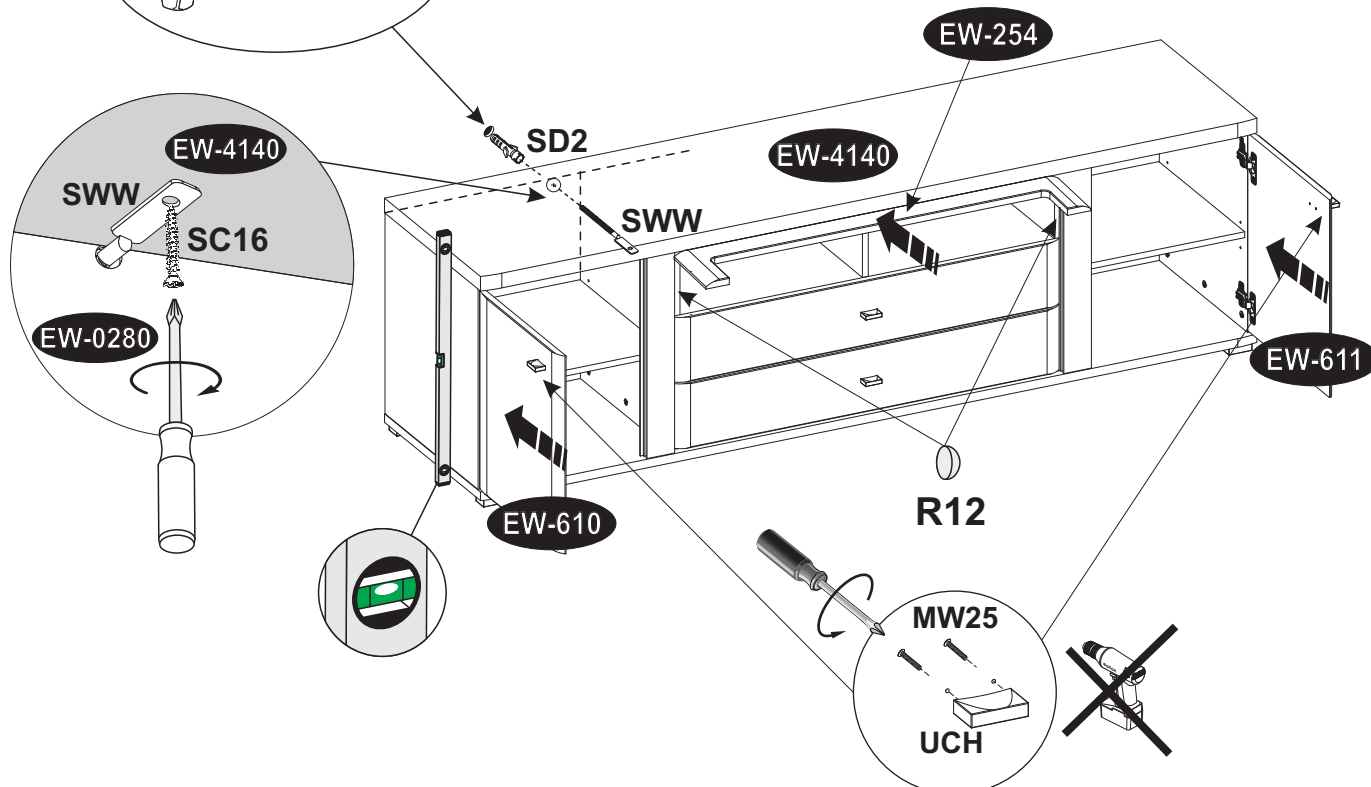
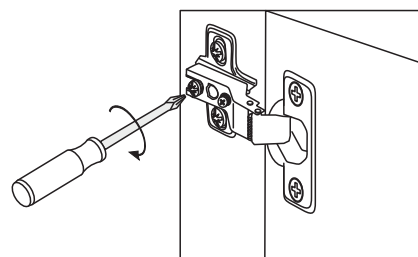
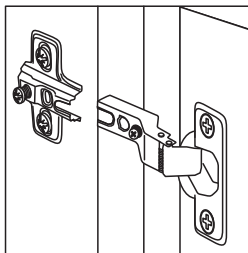
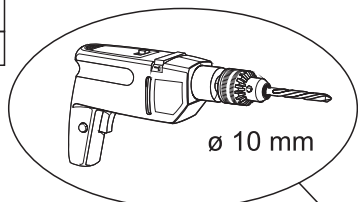

23

R12 x 2 
8 mm



	Uwaga • Upozornini • Achtung • Attention • Caution • Figyelem Attenzione • Opgelet • Внимание • Atentie • Upozornenie • Dikkat	
PL	Mocowanie do ściany jest jednocześnie zabezpieczeniem przed przewróceniem - koniecznie zamontować! Do niektórych rodzajów ścian koniecznie zastosować specjalne kolki mocujące.	
CZ	Montáž na stěnu slouží jako ochrana proti převrnutí - bezpodmínečně umístěte! U některých typů stěn může být zapotřebí speciální hmoždinka!	
D	Wandbefestigung dient als Kippschutz - unbedingt anbringen! Bei einigen Wandtypen kann ein Spezialdübel erforderlich sein!	
GB	The wall fastening serves to prevent tipping - be absolutely sure to mount it! For certain wall types, a special wall plug may be necessary!	
FR	La fixation murale sert de protection contre le basculement - à installer impérativement ! Pour certains types de murs il faut des chevilles spéciales !	
NL	Bevestiging aan de muur dient als kantelbescherming - zeker en vast bevestigen! Bij enkele muurtypen is een speciale plug misschien vereist!	
IT	Il fissaggio alla parete serve da protezione anti-ribaltamento - attaccarla assolutamente! Per alcune strutture di parete può essere necessario un tassello speciale!	
HU	A termék a falhoz kel rögzítési, kűlönb az felborulhat! Egyes fal típusoknál speciális tiplit kell használni!	
RU	Обязательно установите крепление на стене во избежание опрокидывания! Для некоторых типов стен может потребо- ваться специальный дюбель!	
RO	Sistemul de fixare la perete serve ca protecție la răsturnare - de montat obligatoriu! Pentru unele tipuri de pereți este posibil să fie necesar un diblu special!	
SK	Upevnenie na stenu slúži ako ochrana proti prevráteniu - bezpodmienečne použite! Pre niektoré druhy stien môže byť potrebná špeciálna hmoždinka!	
TR	Duvardaki sabitleme, devrilmeye karşı bir emniyet tedbiridir ve mutlaka monte edilmelidir! Bazi duvar tiplerinde bunun için özel bir dübel gerekli olabilir!	

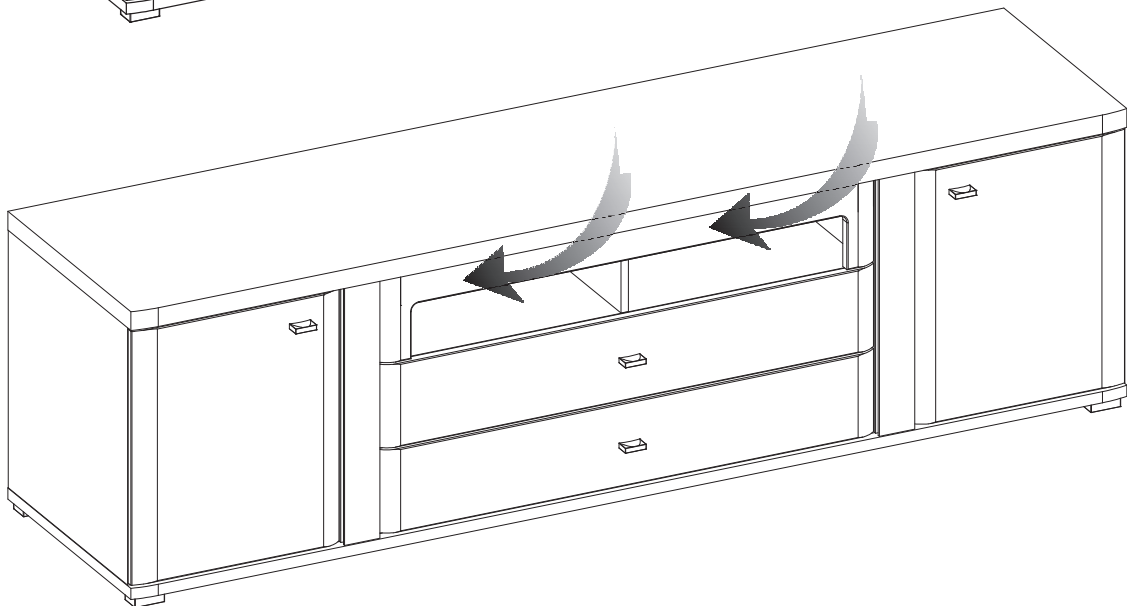
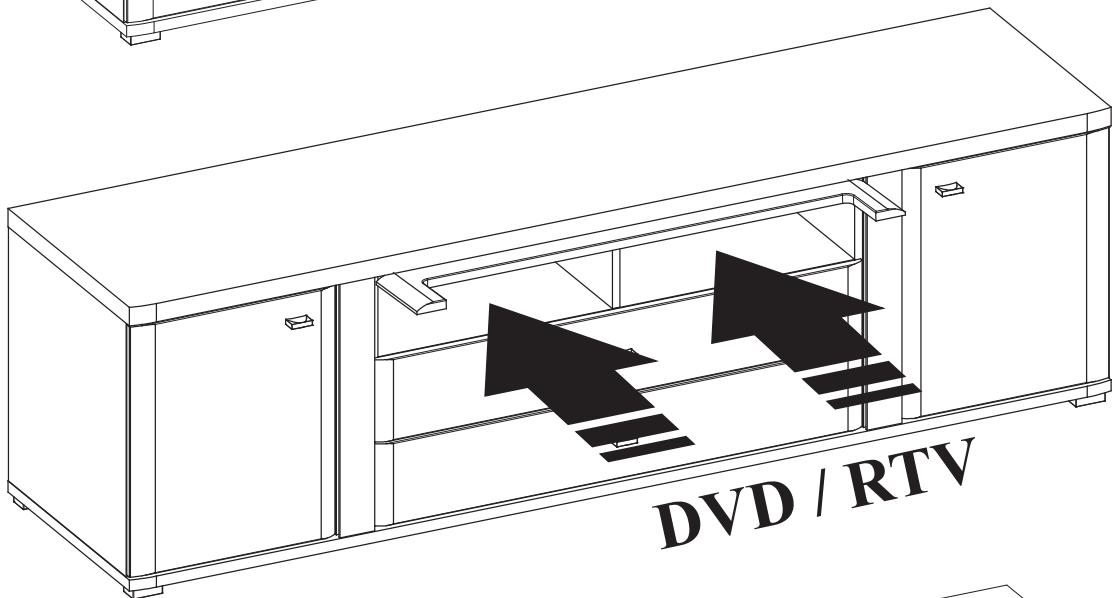
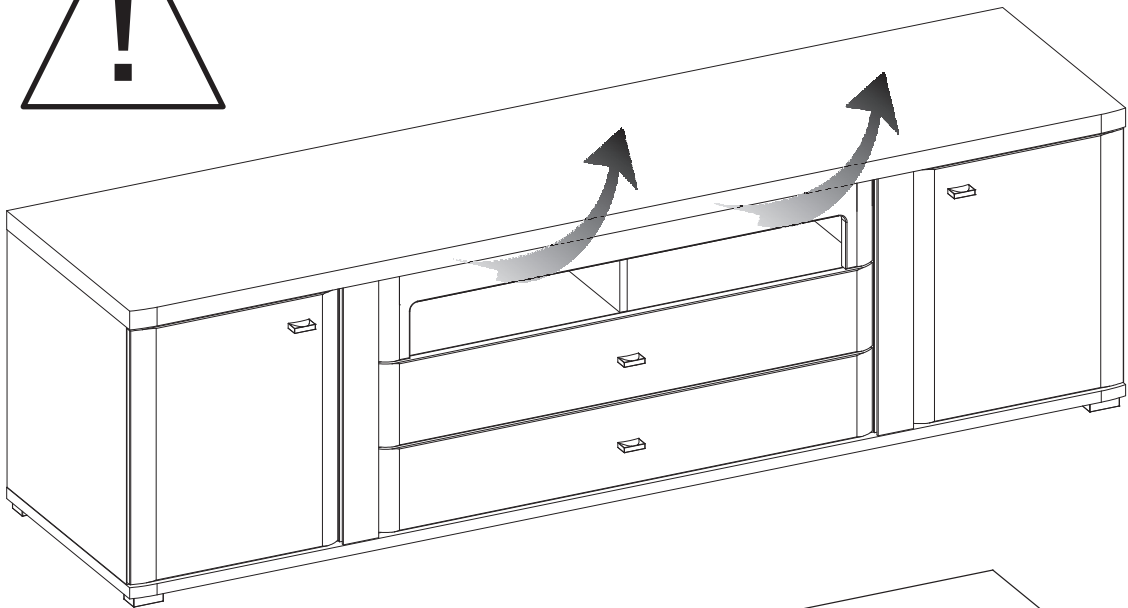

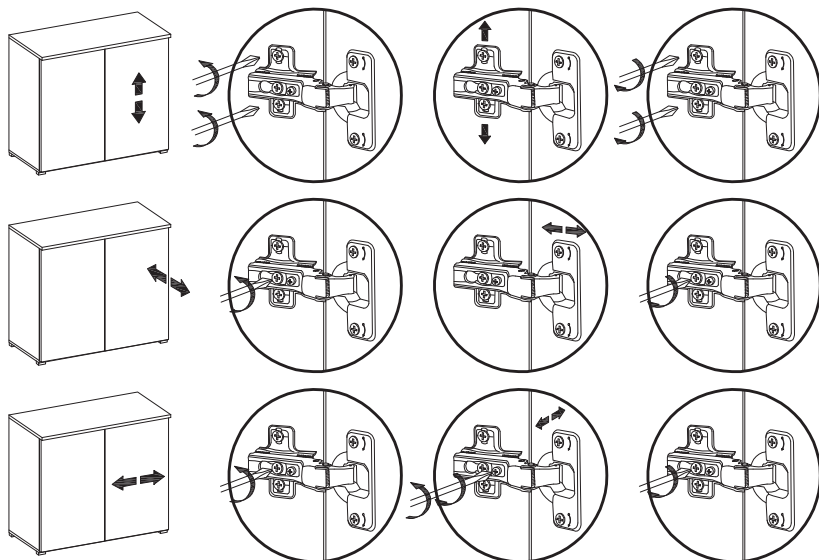

- (F) Mettre la porte (égaler les gonds)
- (I) Regolare la porta (livellare le parentesi)
- (D) Turen einstellen (Scharniere justieren)
- (GB) Adjusting the doors (adjusting the hinges)
- (NL) Deuren instellen (scharnieren afstellen)
- (PL) Nastawic drzwi (wyrownac zawiasy)
- (TR) Kapilarin ayarlanmasi (menteşelerin seviye ayari)
- (RU) Регулировка дверей (регулировка шарнира)
- (RO) Ajustați ușa (aliniati balamalele)
- (CZ) Seřid'te dveře (vyrovnejte závěsy)
- (SK) Zrad'te dvere (vyrovnajte závesy)
- (HU) Állítsa be az ajtó (igazítsa be a zsanérokot)

GL x 2	EM x 1
	BYDGOSKIE MEBLE

25

