

READ AND SAVE THIS INSTRUCTIONS FOR USE

# ASSEMBLY & INSTRUCTION MANUAL

MADE IN P.R.C

# Before You Start

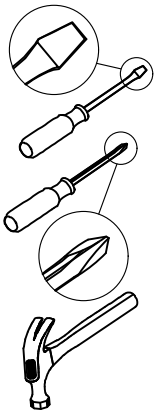

- ✓ Read through each step carefully and follow the proper order
- ✓ Separate and count all your parts and hardware
- ✓ Give yourself enough room for the assembly process
- ✓ Have the following tools: Flat Head Screwdriver, #2 Phillips Head Screwdriver and Hammer
- ✓ Caution: If using a power drill or power screwdriver for screwing, please pay attention to slow down and stop when screw is tight. Failure to do so may result in stripping the screw. (Assembly speed can be increased by using electric screwdriver)

# Helpful Hints

## PEOPLE NEEDED FOR ASSEMBLY: 1-2

- Open your item in the area you plan to keep it to avoid excessive heavy lifting.



- Identify, sort and count the parts before attempting assembly.

- Compression dowels are lightly tapped in with a hammer.



- Slides are labeled with an **R** (right) and **L** (left) for proper placement.

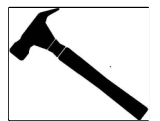

- Make sure to always face the point on the top of the Cam Lock towards the outer edge.

- If there is a back panel in the package, please install it to make sure your unit is complete and sturdy.



- Please fix all the screws provided for the back panel which can enhance product stability. If it is difficult to fix it when tightening, it can be fixed with the help of a hammer and then tightened.



- Do NOT use harsh chemicals or abrasive cleaners on this item.

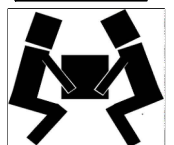

- Never push, pull, or drag your furniture.

# Board Identification

Not actual size

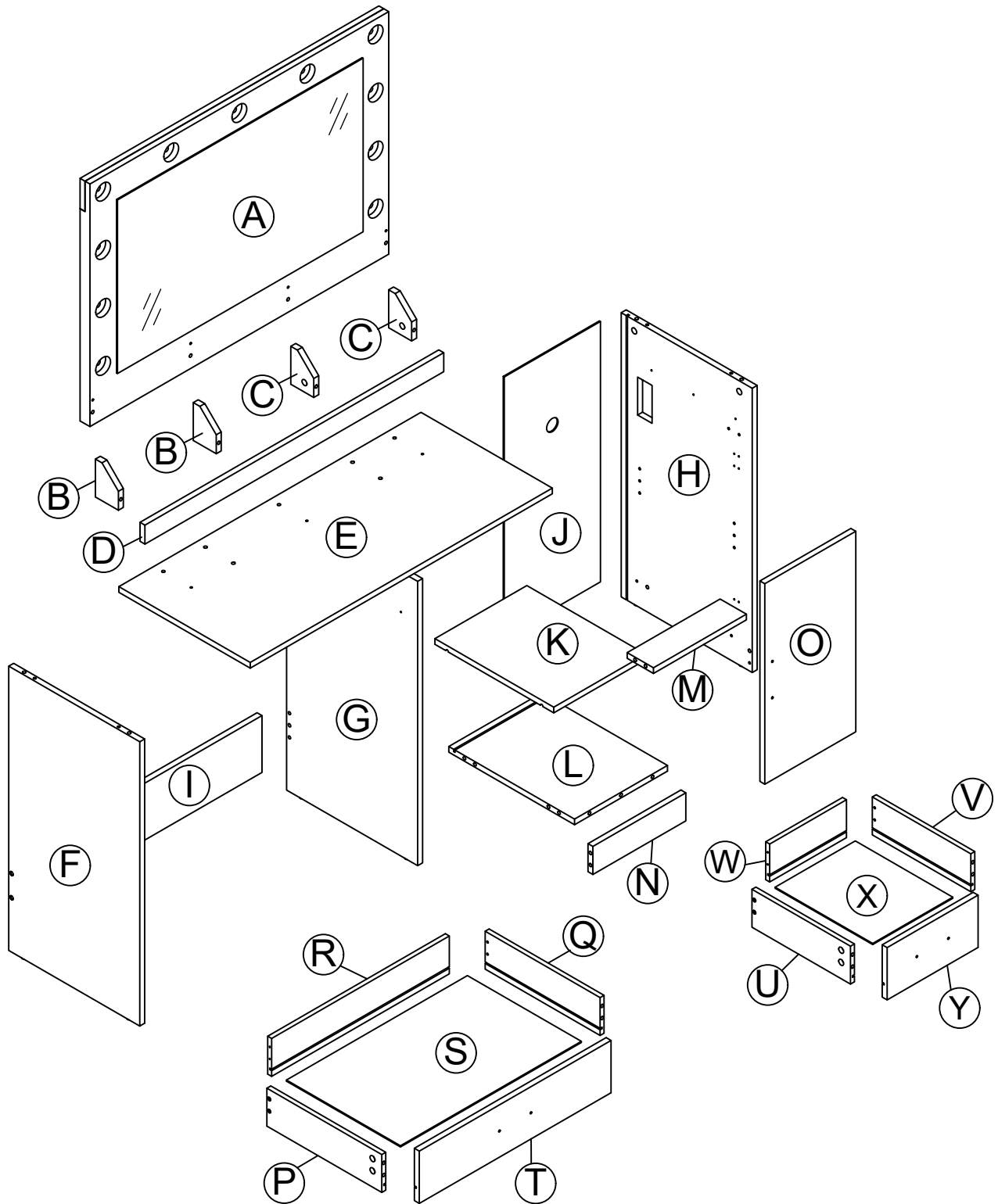

# Board Identification

Not actual size

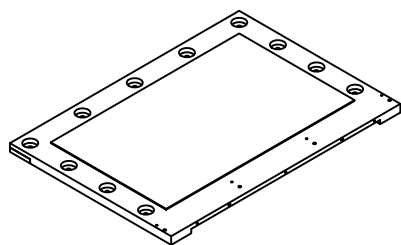

(A)

DRESSING MIRROR  
Qty:1

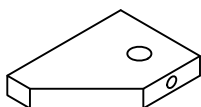

(B)

HUTCH FIXED SHELF  
Qty:2

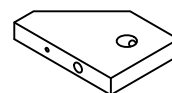

(C)

HUTCH FIXED SHELF  
Qty:2

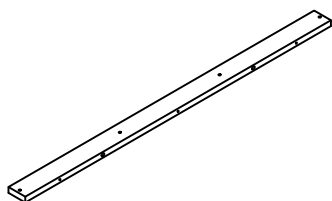

(D)

HUTCH FIXED SHELF  
Qty:1

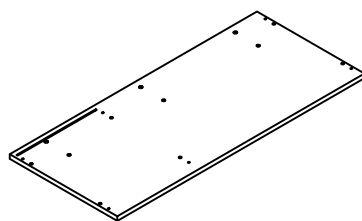

(E)

TOP  
Qty:1

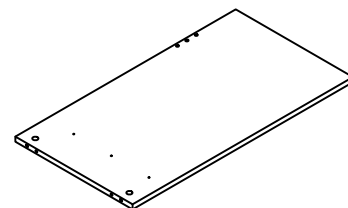

(F)

LEFT SIDE PANEL  
Qty:1

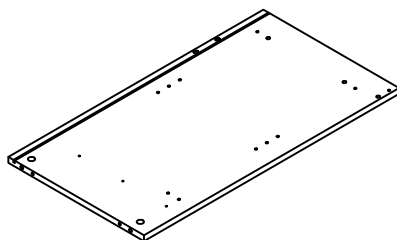

(G)

MIDDLE PANEL  
Qty:1

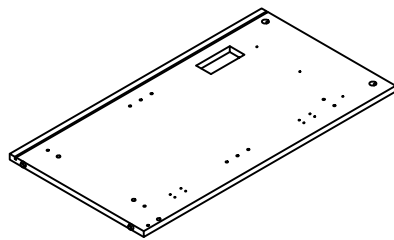

(H)

RIGHT SIDE PANEL  
Qty:1

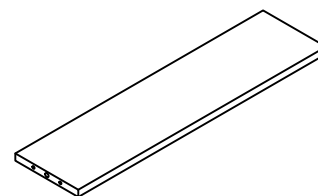

(I)

LOWER BACK SLAT  
Qty:1

# Board Identification

Not actual size

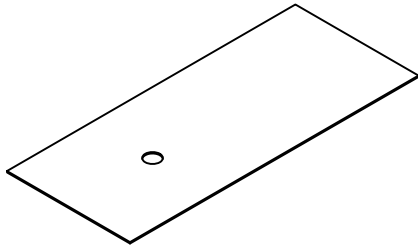

ⓐ

RIGHT BACK PANEL  
Qty:1

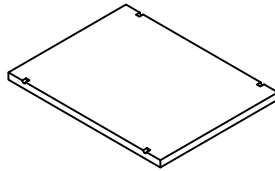

ⓑ

MOVABLE SHELVES  
Qty:1

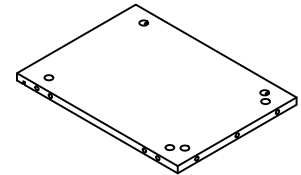

ⓒ

RIGHT BOTTOM BOARD  
Qty:1

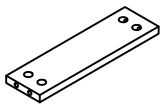

ⓓ

RIGHT PARTITION  
Qty:1

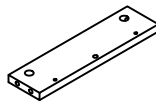

ⓔ

RIGHT FRONT SLAT  
Qty:1

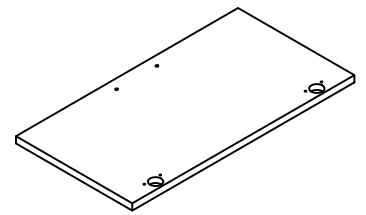

ⓕ

DOOR  
Qty:1

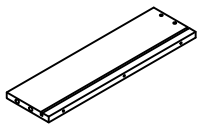

ⓖ

BIG DRAWER LEFT  
SIDE  
Qty:1

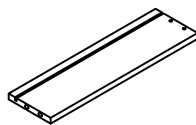

ⓗ

BIG DRAWER RIGHT  
SIDE  
Qty:1

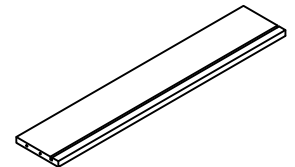

ⓘ

BIG DRAWER BACK  
PANEL  
Qty:1

# Board Identification

Not actual size

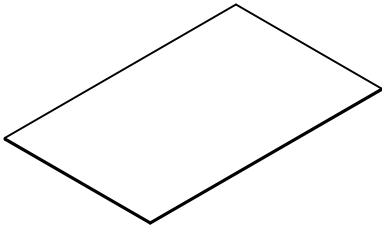

Ⓢ

BIG DRAWER BOTTOM  
Qty:1

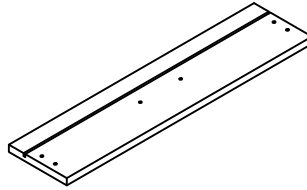

Ⓣ

BIG DRAWER FRONT  
Qty:1

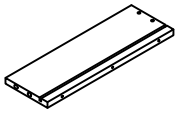

Ⓤ

SMALL DRAWER LEFT  
SIDE  
Qty:1

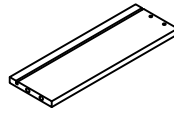

Ⓥ

SMALL DRAWER  
RIGHT SIDE  
Qty:1

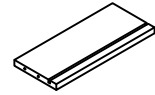

Ⓦ

SMALL DRAWER BACK  
PANEL  
Qty:1

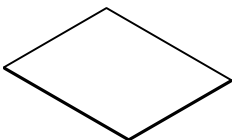

Ⓧ

SMALL DRAWER BOTTOM  
Qty:1

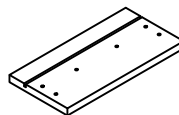

Ⓨ

SMALL DRAWER FRONT  
Qty:1

# Part List

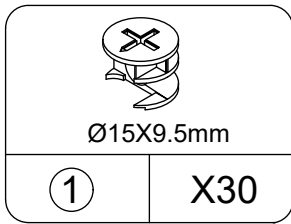

CAM LOCK  
spare:2

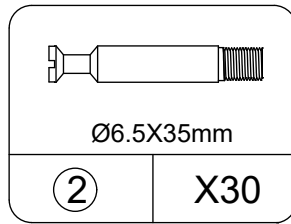

CAM BOLT  
spare:2

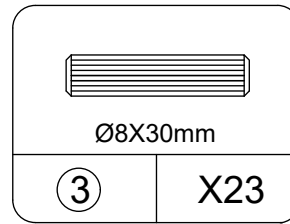

WOOD DOWEL  
spare:2

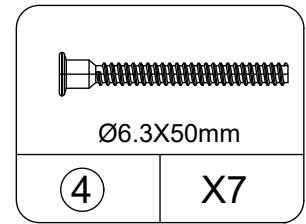

SCREW

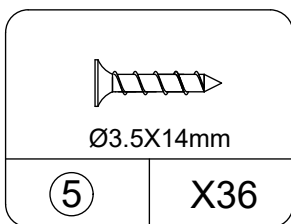

SCREW  
spare:2

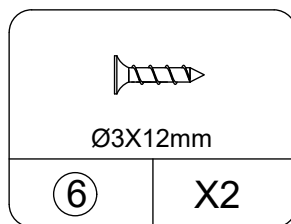

SCREW

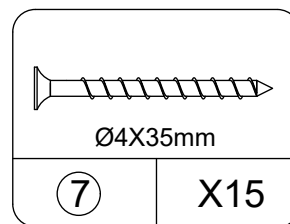

SCREW  
spare:1

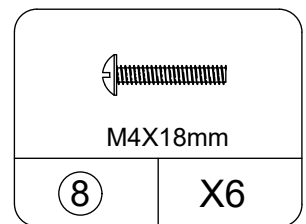

SCREW

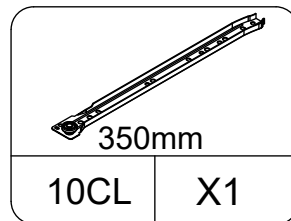
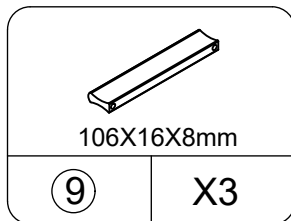

LEFT CABINET MEMBER

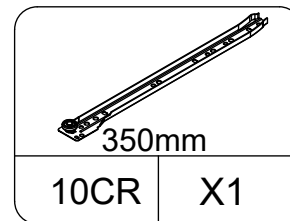

RIGHT CABINET MEMBER

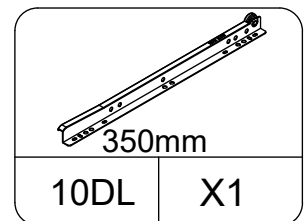

LEFT DRAWER RUNNER

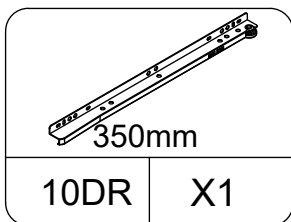

RIGHT DRAWER RUNNER

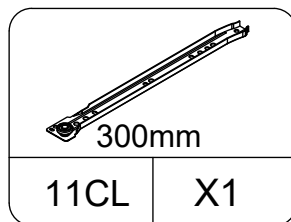

LEFT CABINET MEMBER

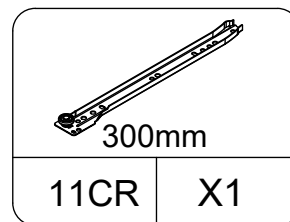

RIGHT CABINET MEMBER

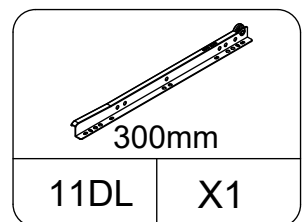

LEFT DRAWER RUNNER

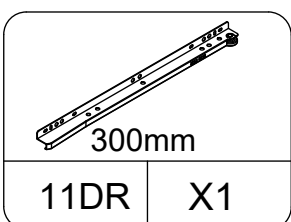

RIGHT DRAWER RUNNER

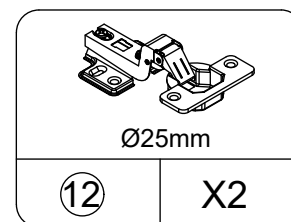

HINGE

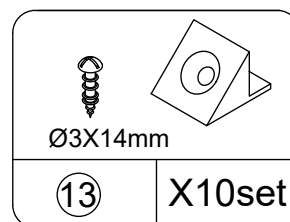

BACK PANEL BUCKLE  
spare:1

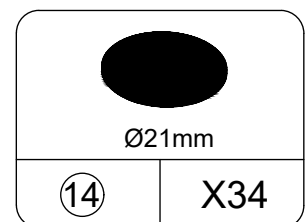

PERFECT STICKER  
spare:2

# Part List

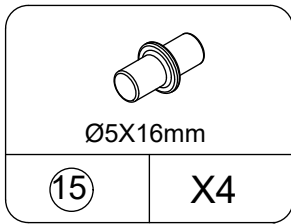

SHELF SUPPORT

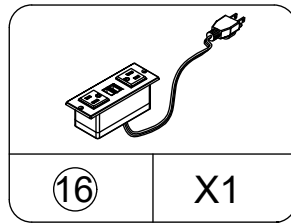

POWER STRIP

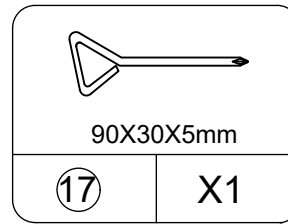

HEX KEY

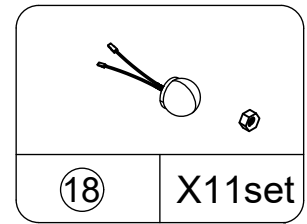

LIGHT BULB  
spare:1

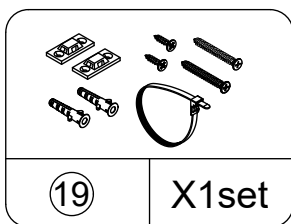

TIPPING RESTRAINT  
HARDWARE KIT

## Cam Lock Fastening System

Insert the cam bolt into the hole first, then insert the cam lock and lock it.

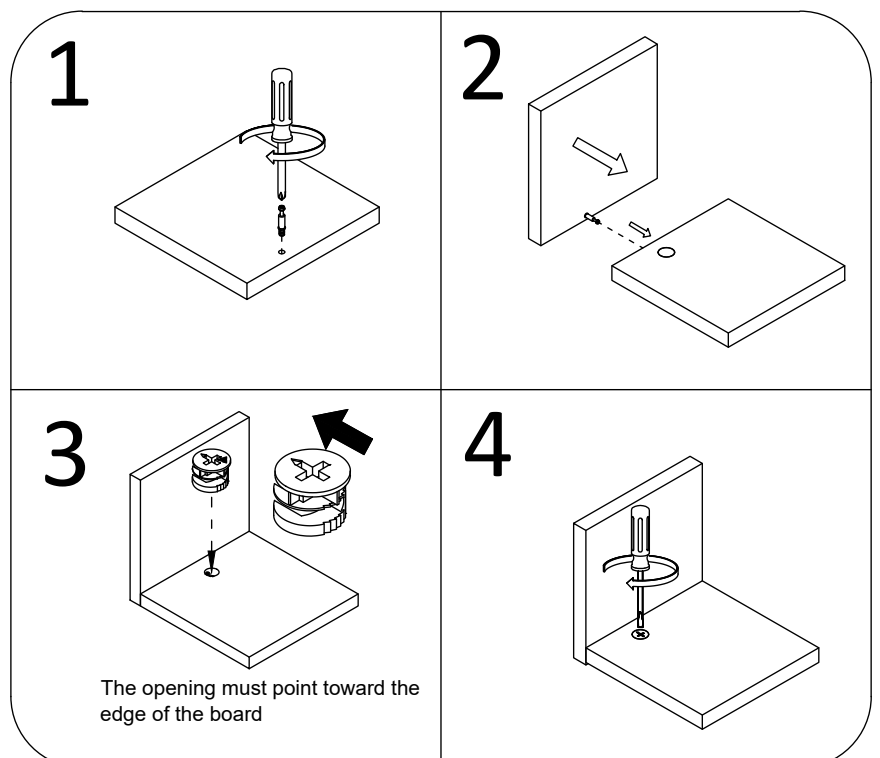

# STEP 1

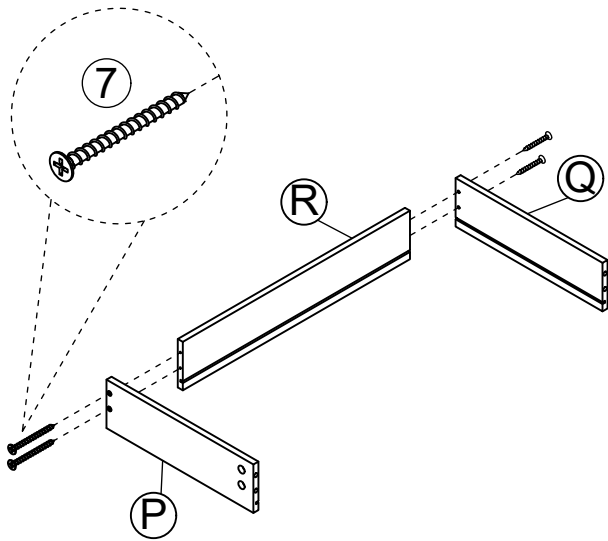
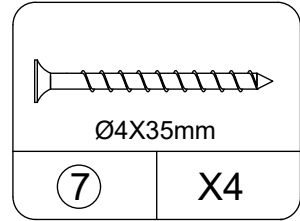
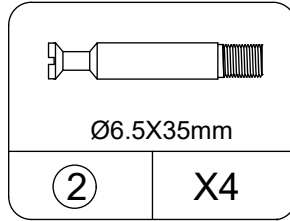
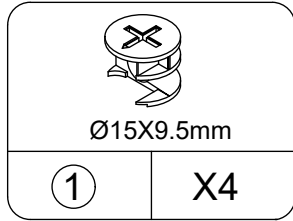
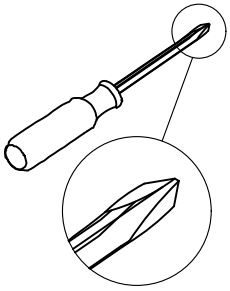

Step 1

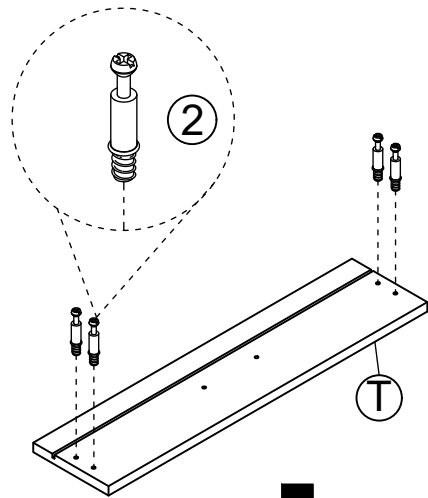

Step 2

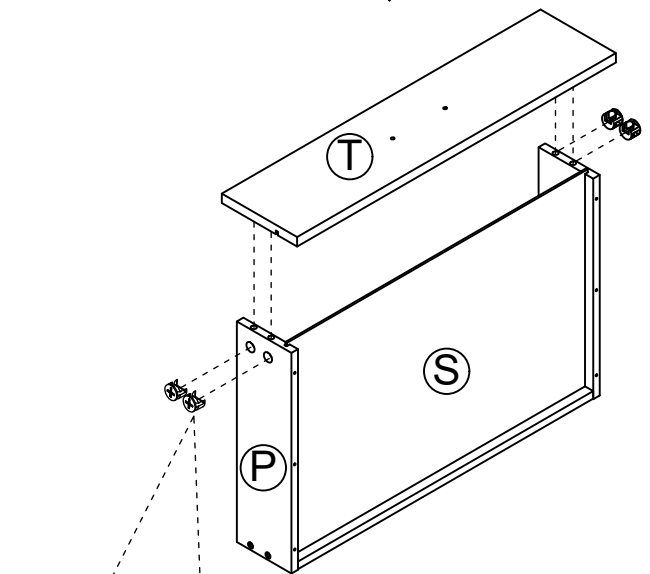
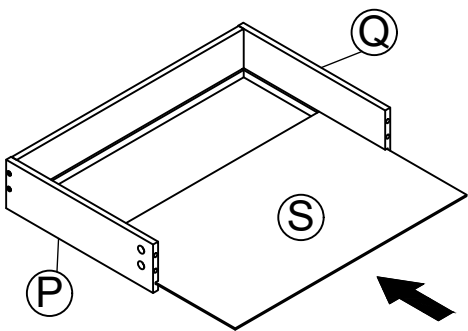

Step 3

Insert the cam bolt into the hole first, then insert the cam lock and lock it.

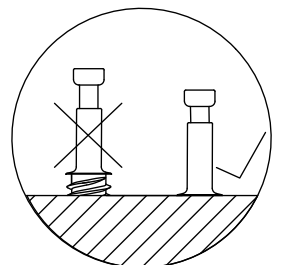
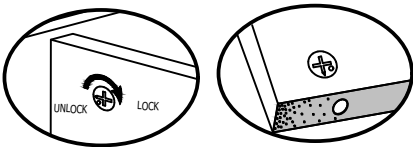

# STEP 2

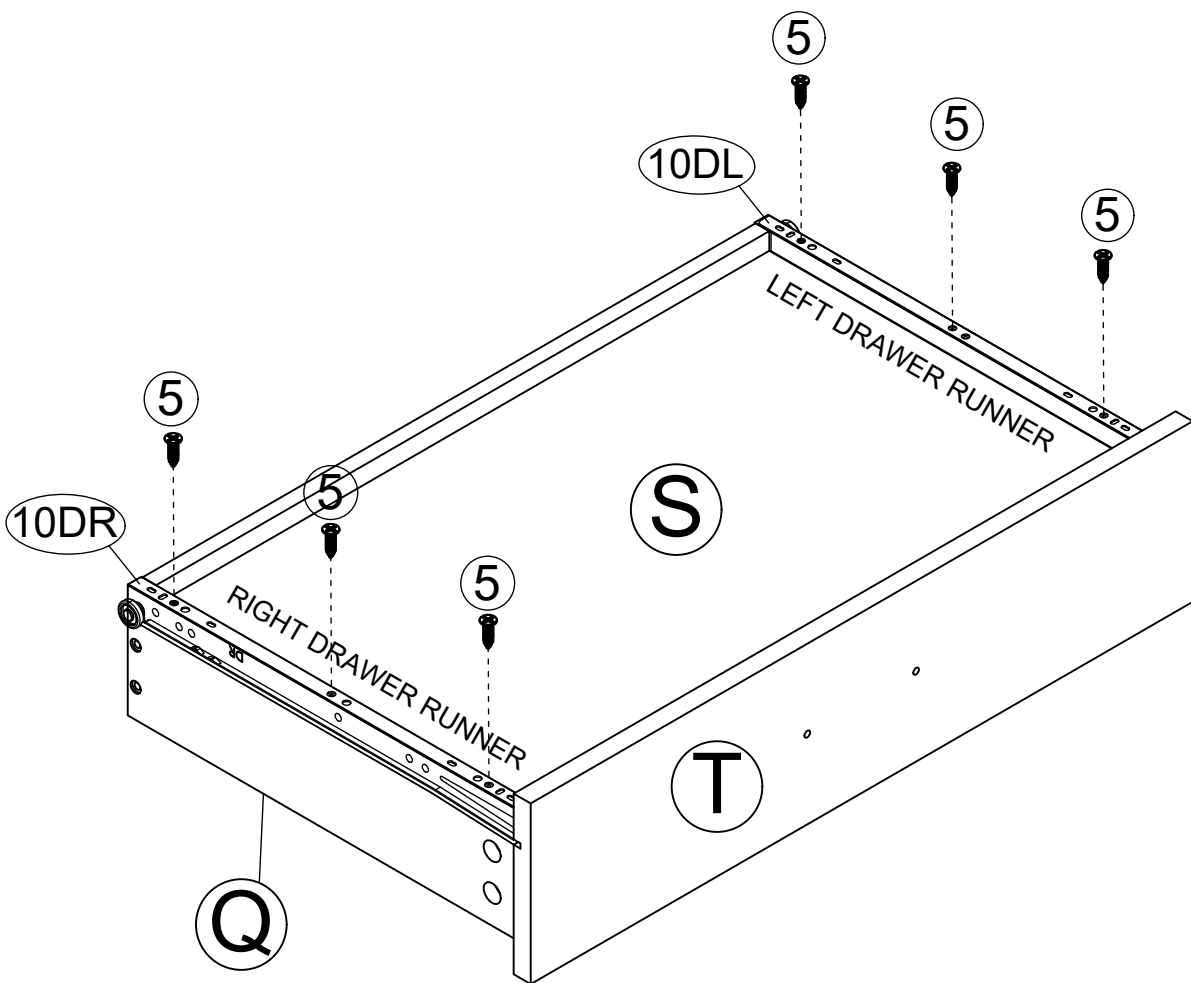
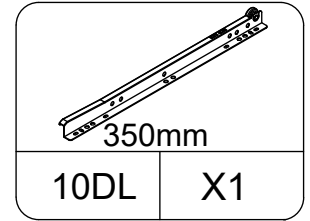
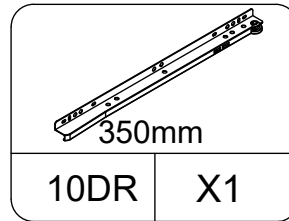
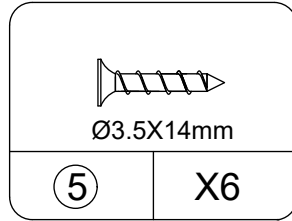
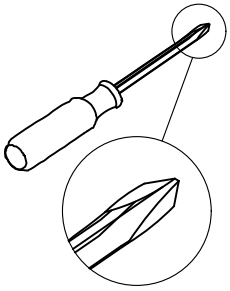

# STEP 3

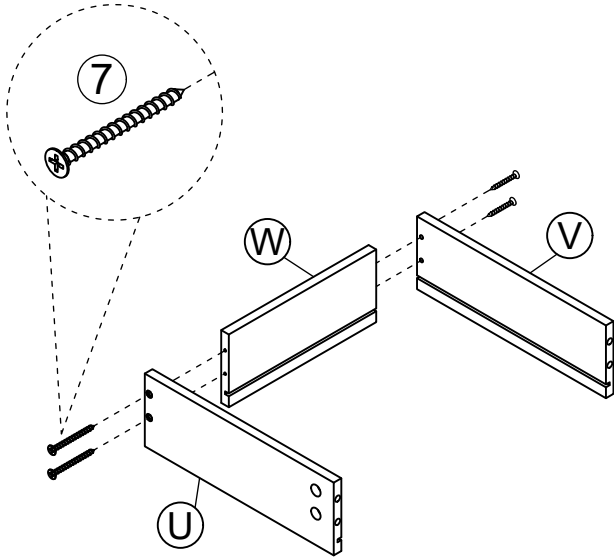
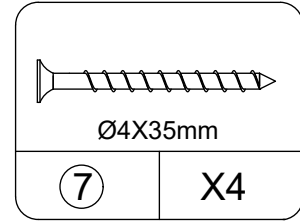
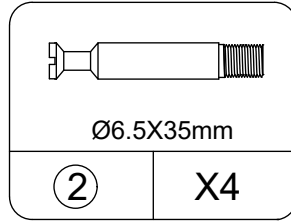
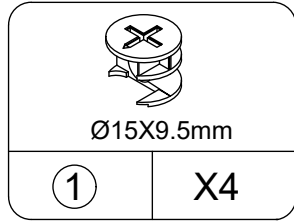
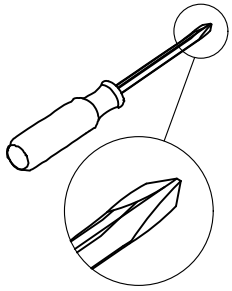

Step 1

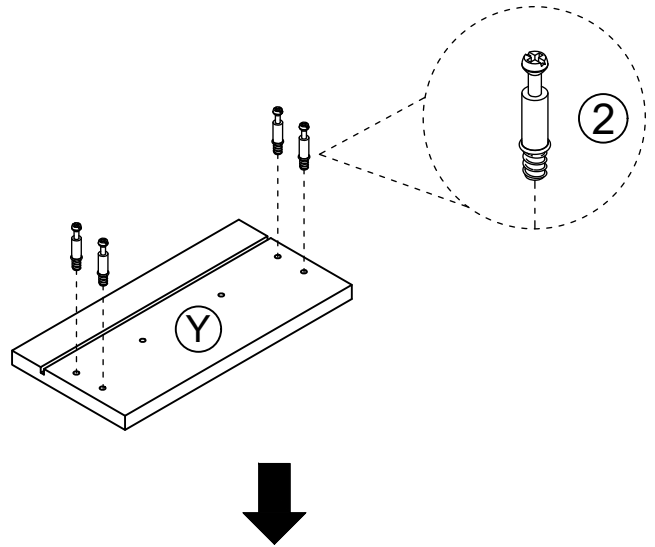

Step 2

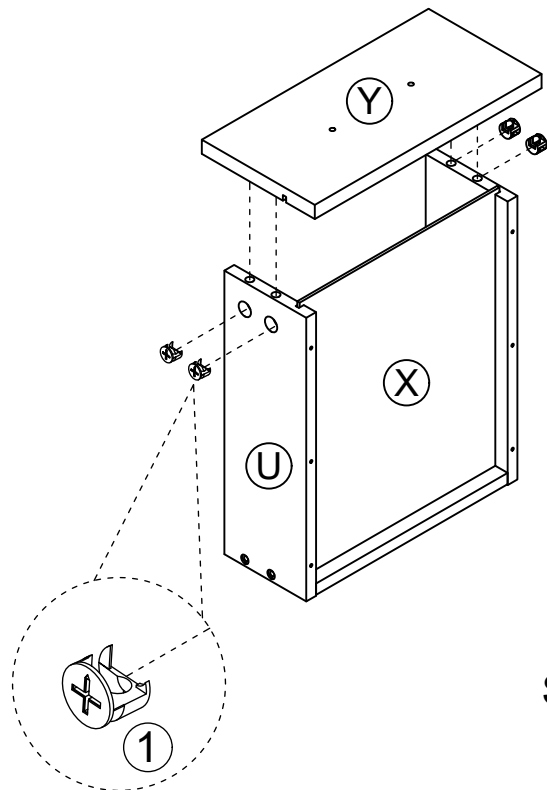
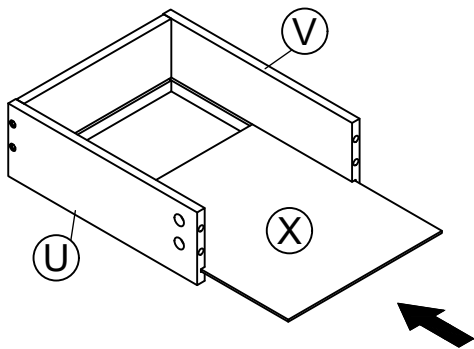

Step 3

Insert the cam bolt into the hole first, then insert the cam lock and lock it.

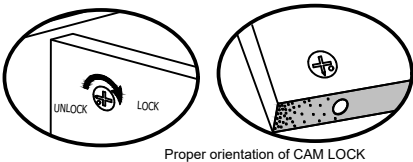

Proper orientation of CAM LOCK

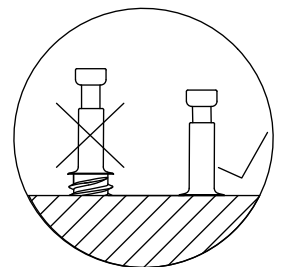

# STEP 4

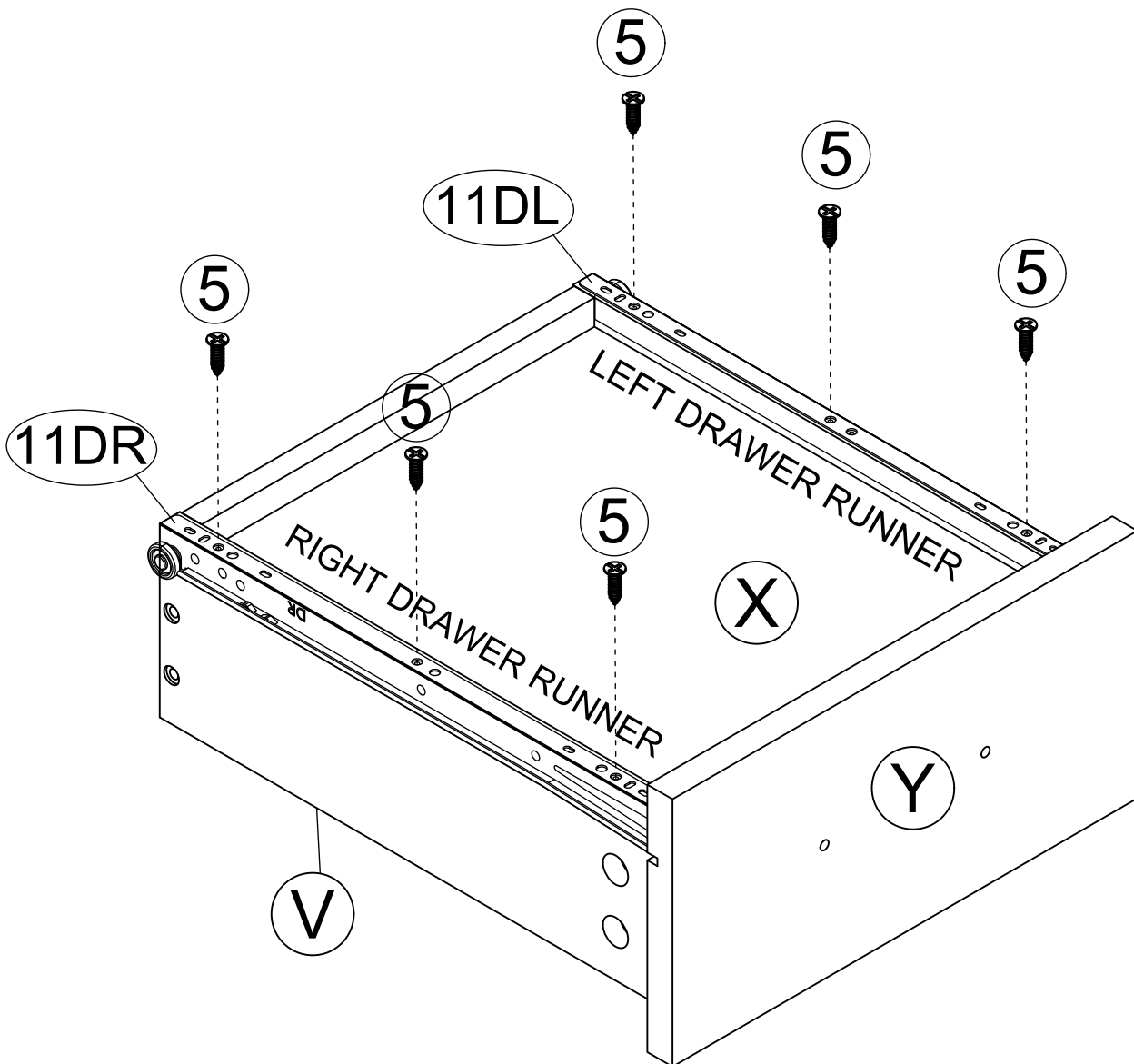
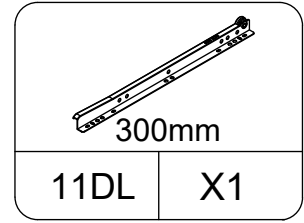
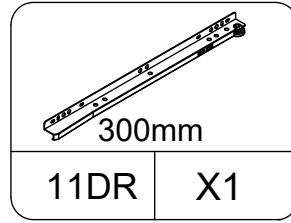
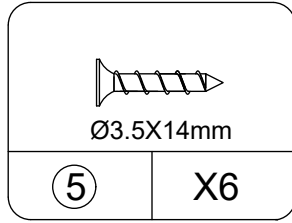
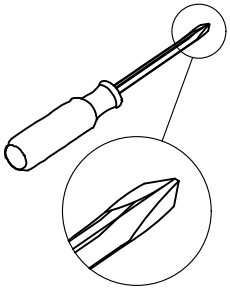

# STEP5

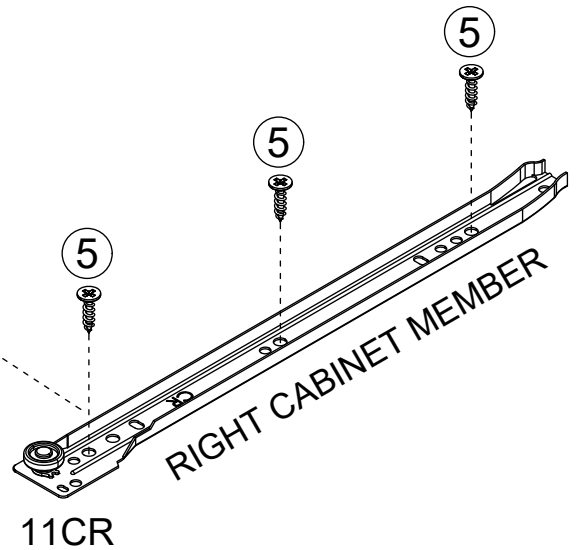
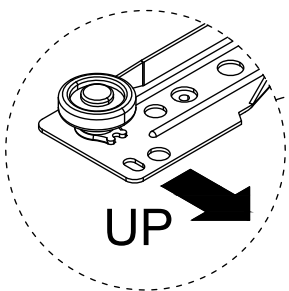
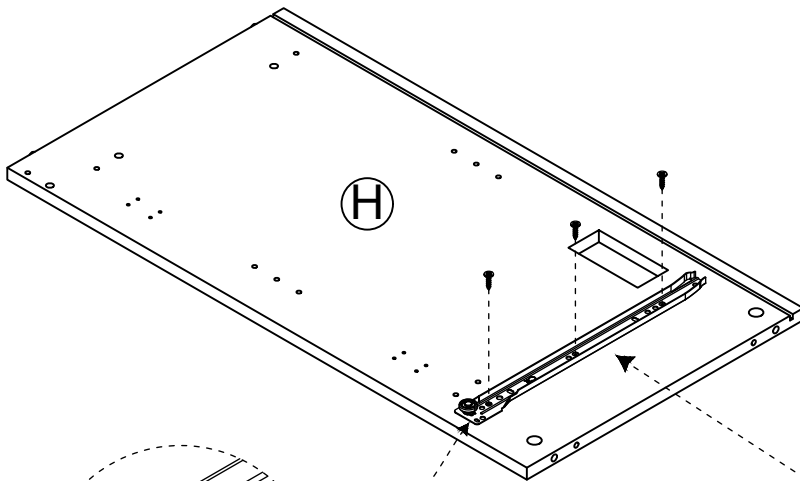
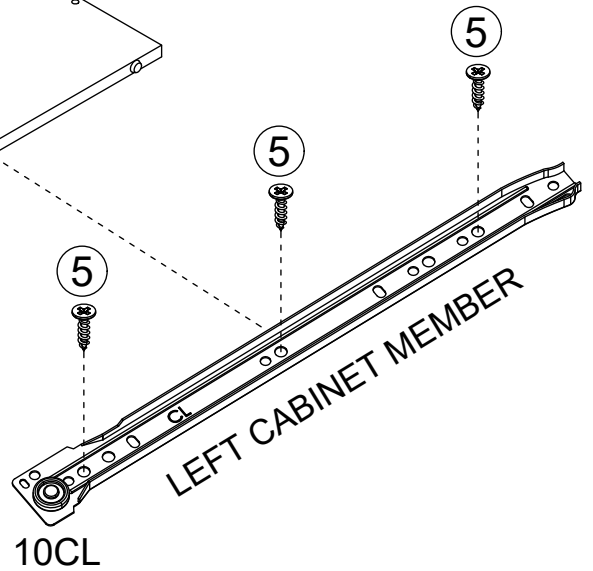
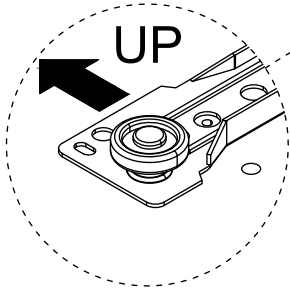
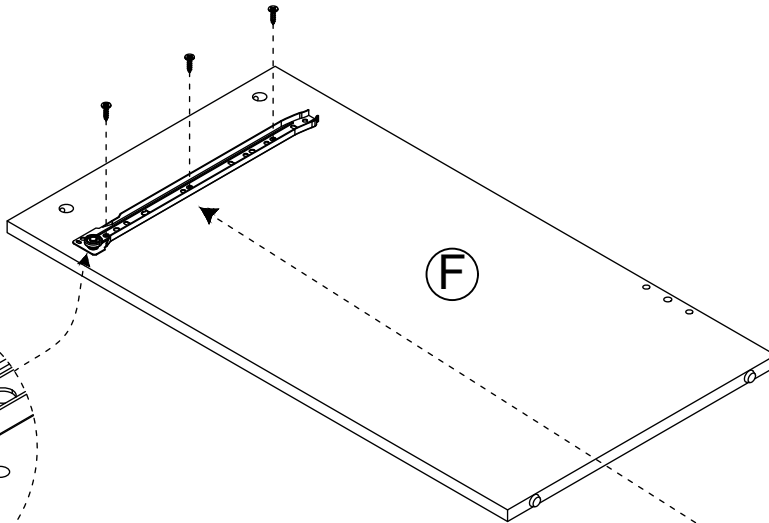
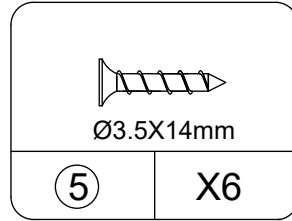
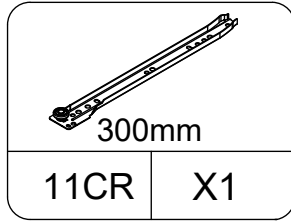
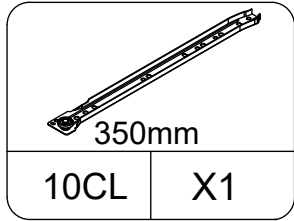
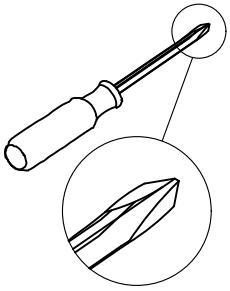

# STEP 6

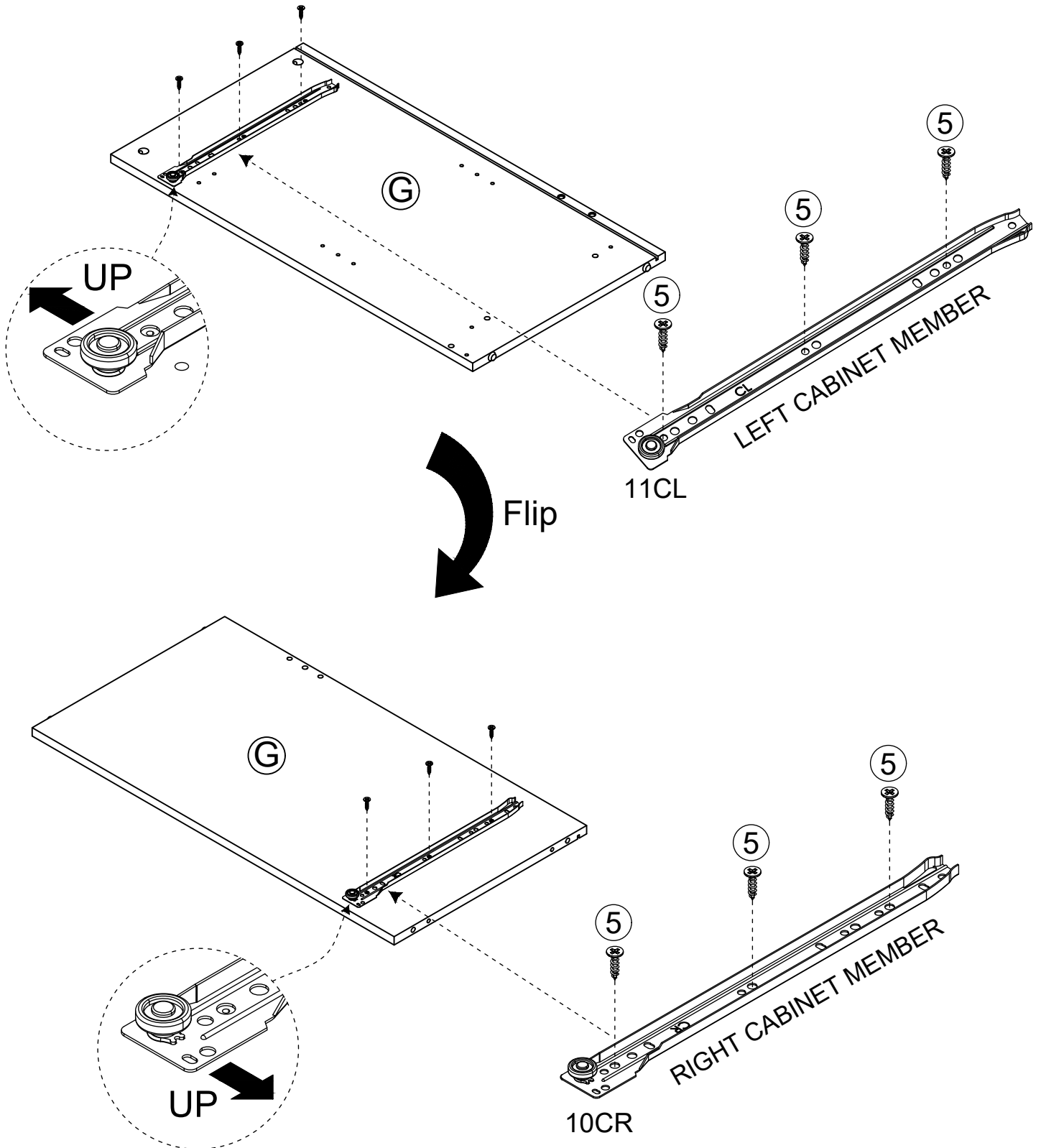
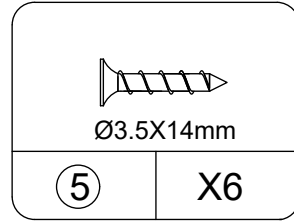
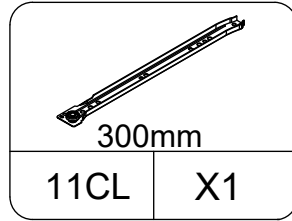
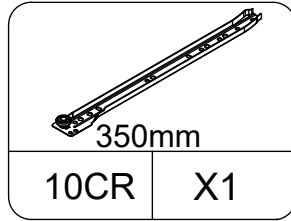
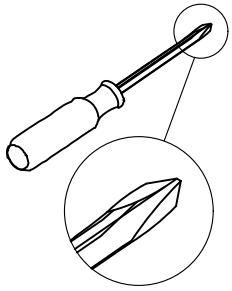

# STEP 7

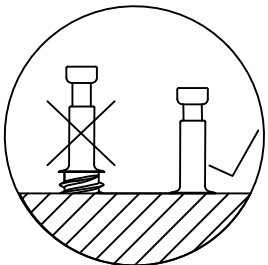
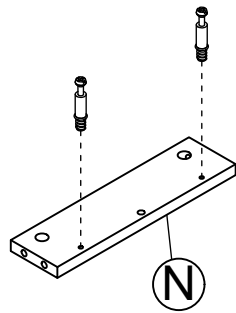
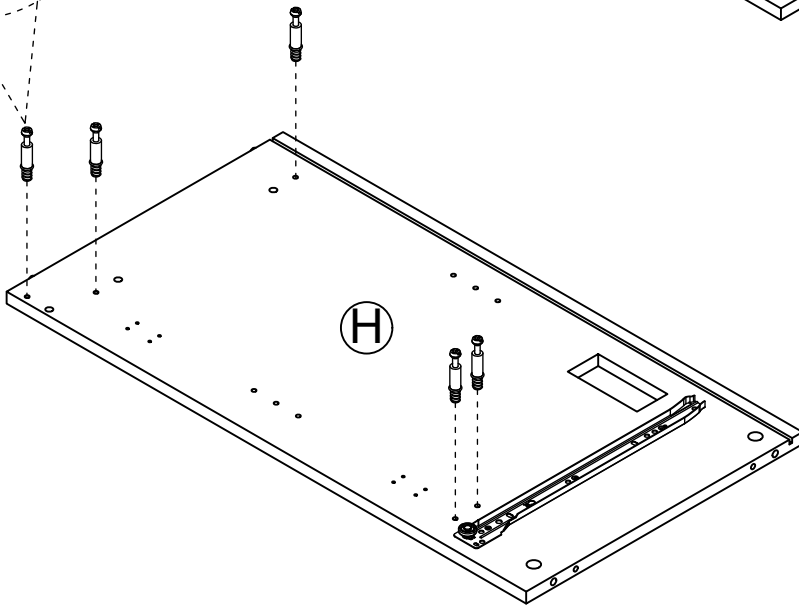
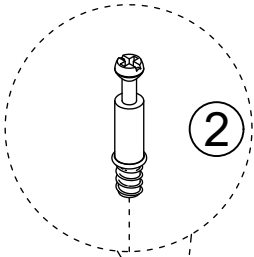
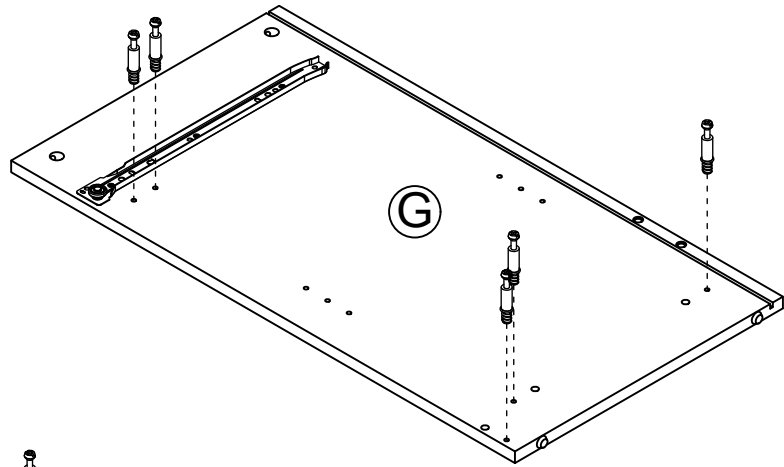
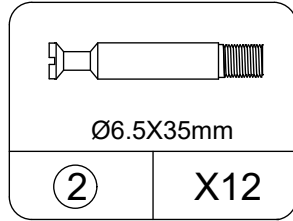
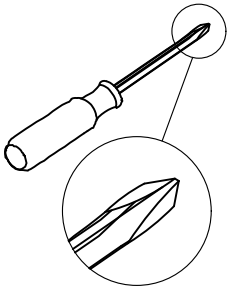

# STEP 8

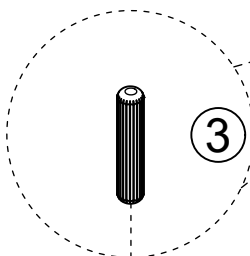
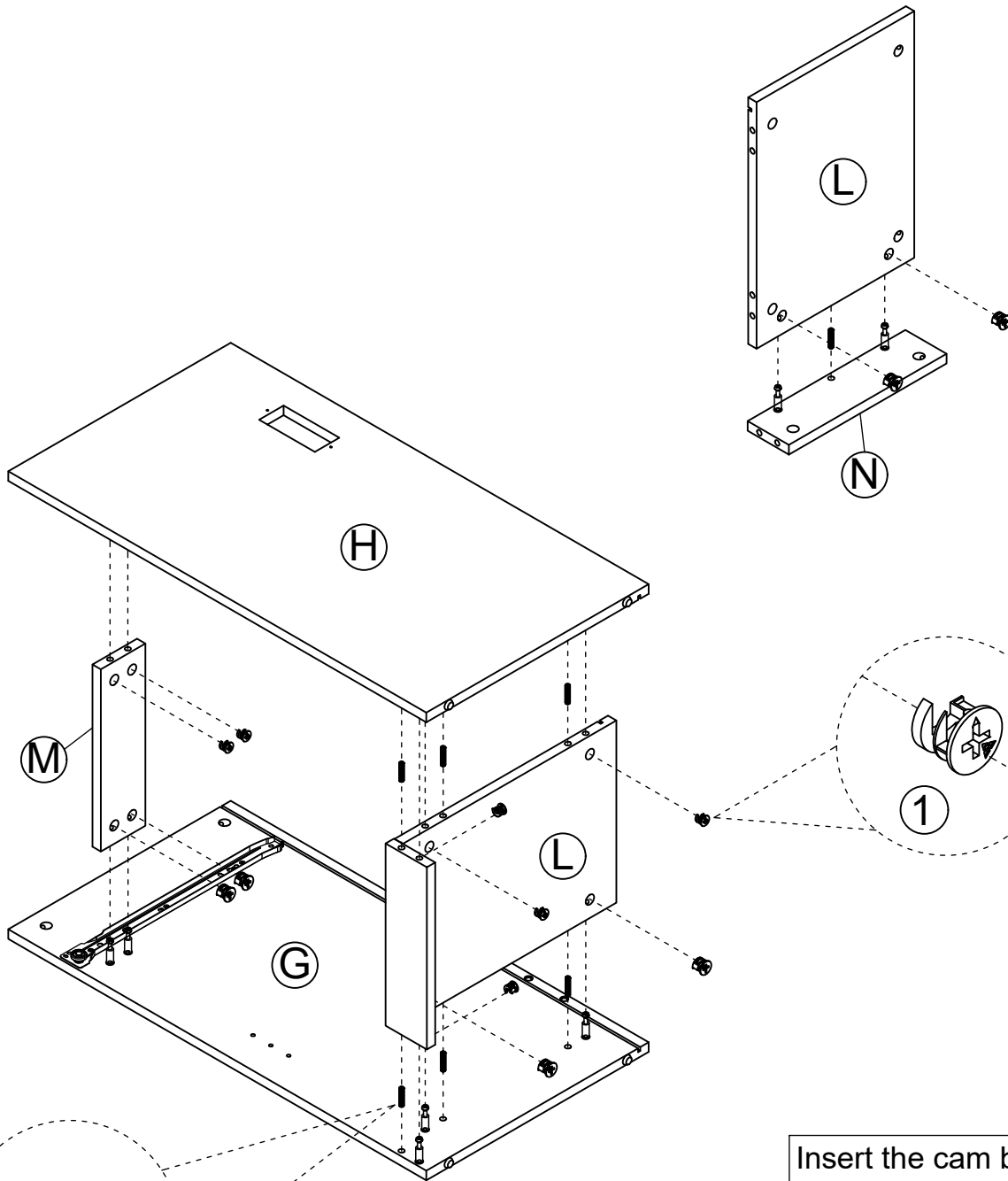
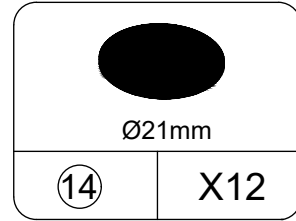
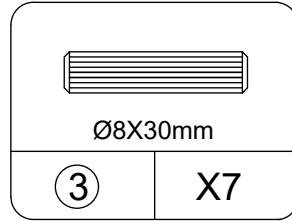
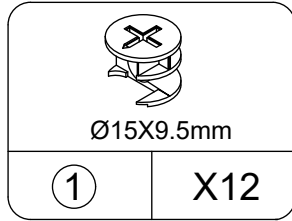
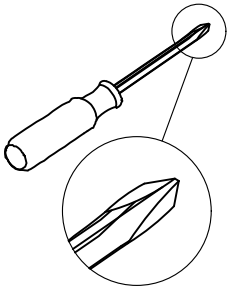

Insert the cam bolt into the hole first, then insert the cam lock and lock it.

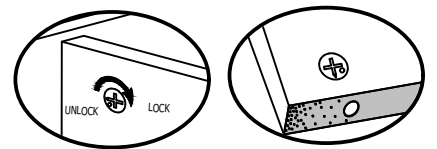

# STEP 9

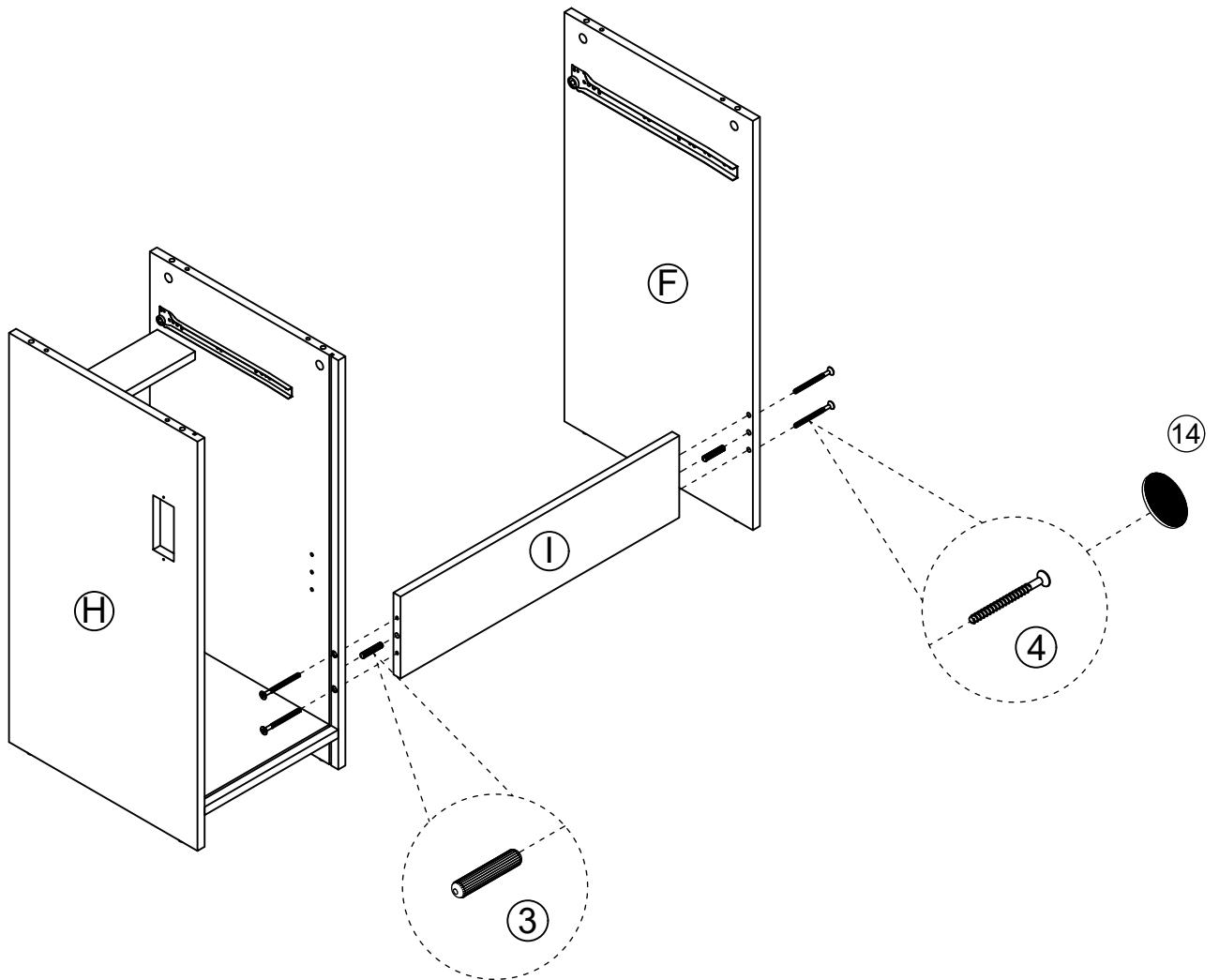
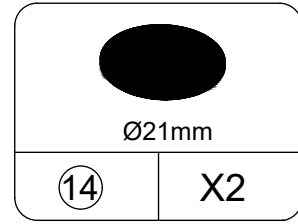
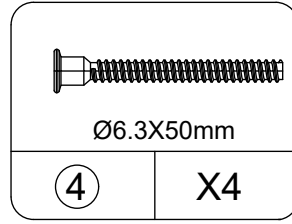
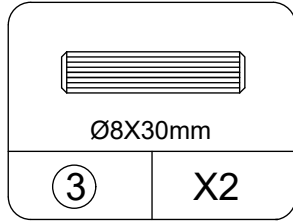
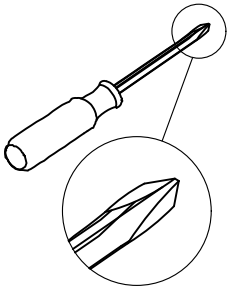

# STEP 10

---

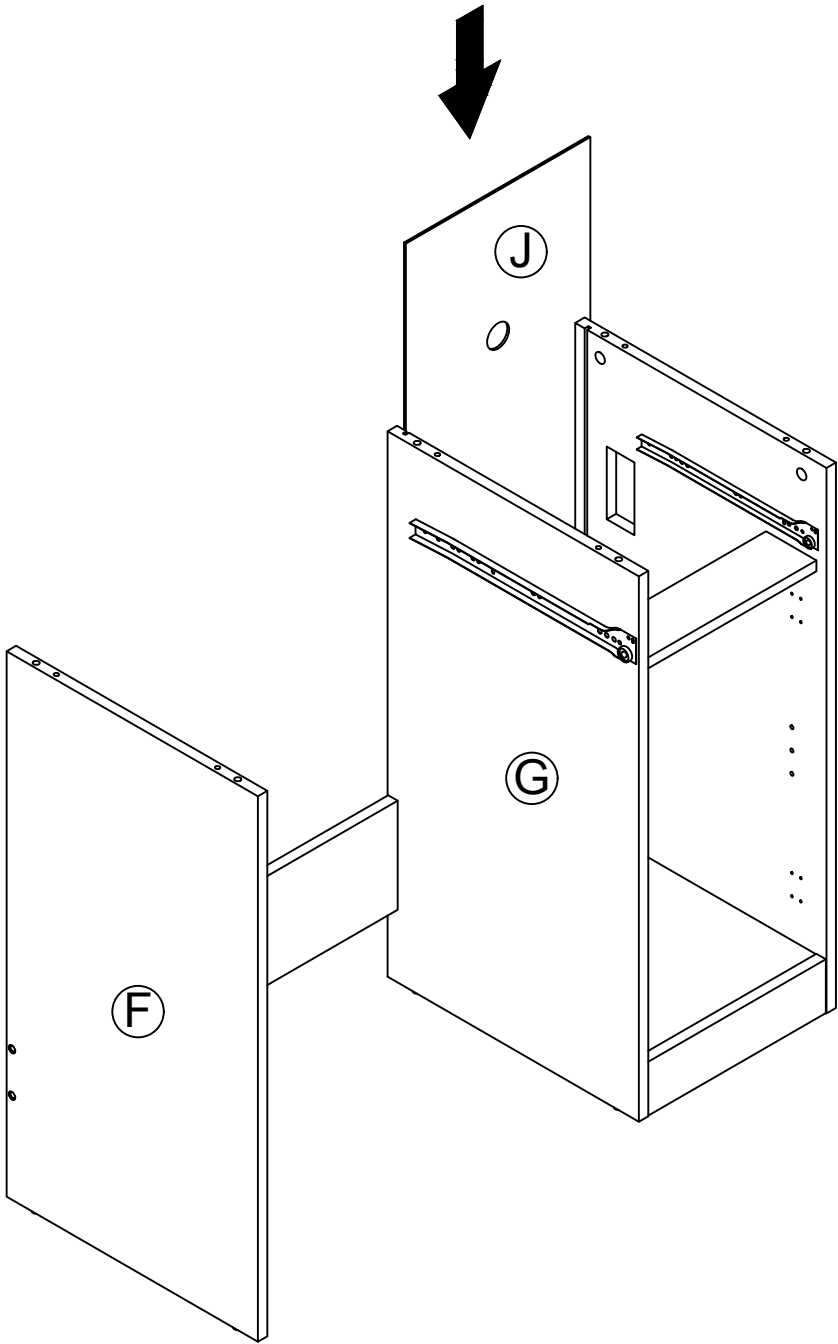

# STEP 11

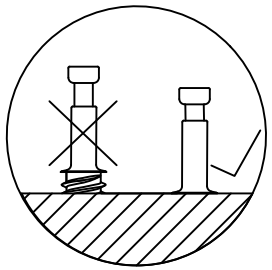
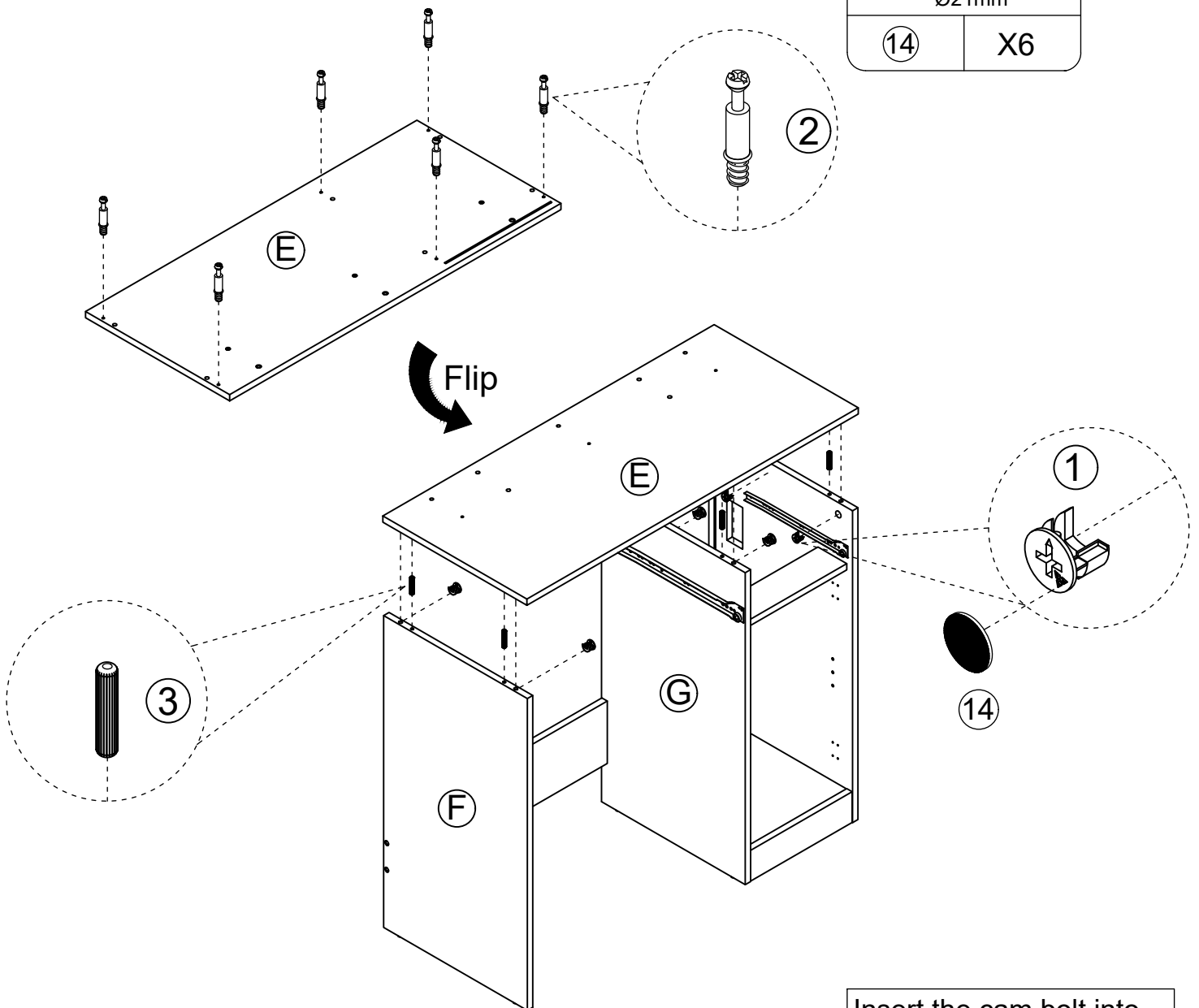
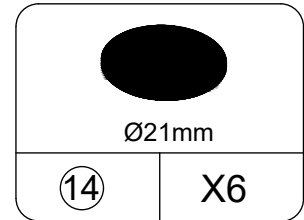
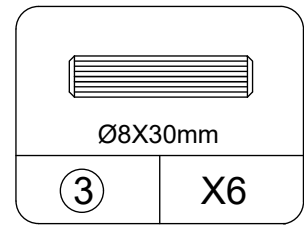
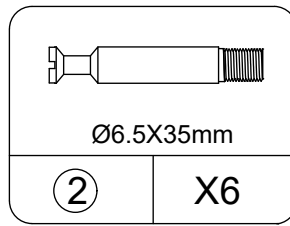
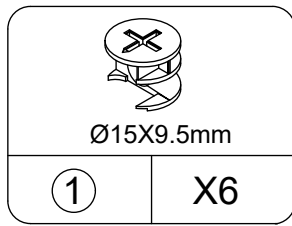
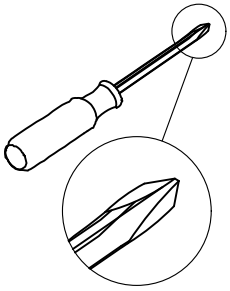

Insert the cam bolt into the hole first, then insert the cam lock and lock it.

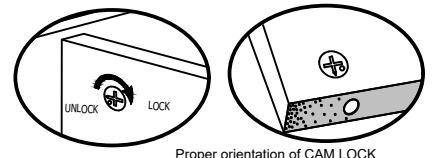

# STEP 12

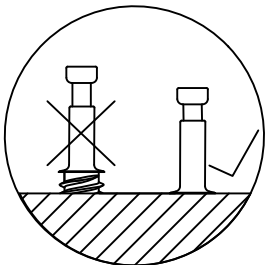
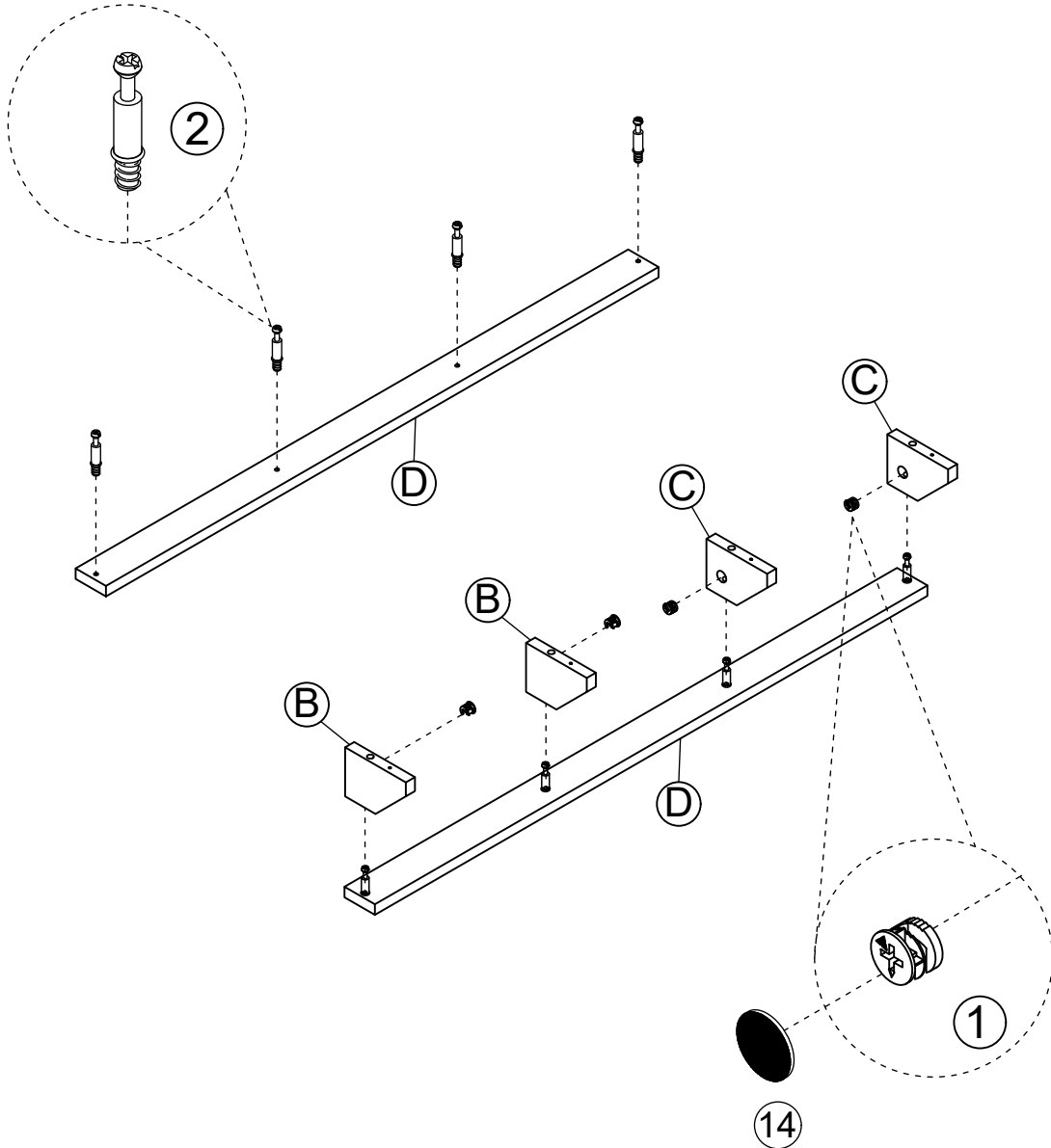
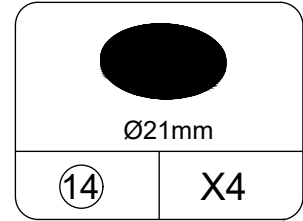
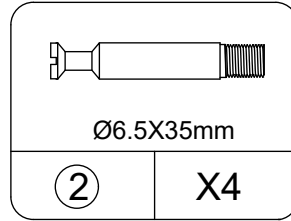
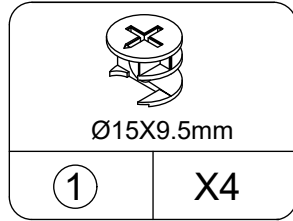
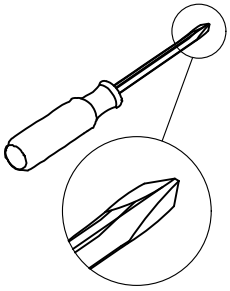

Insert the cam bolt into the hole first, then insert the cam lock and lock it.

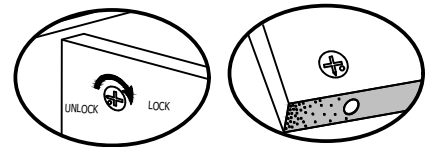

Proper orientation of CAM LOCK

# STEP13

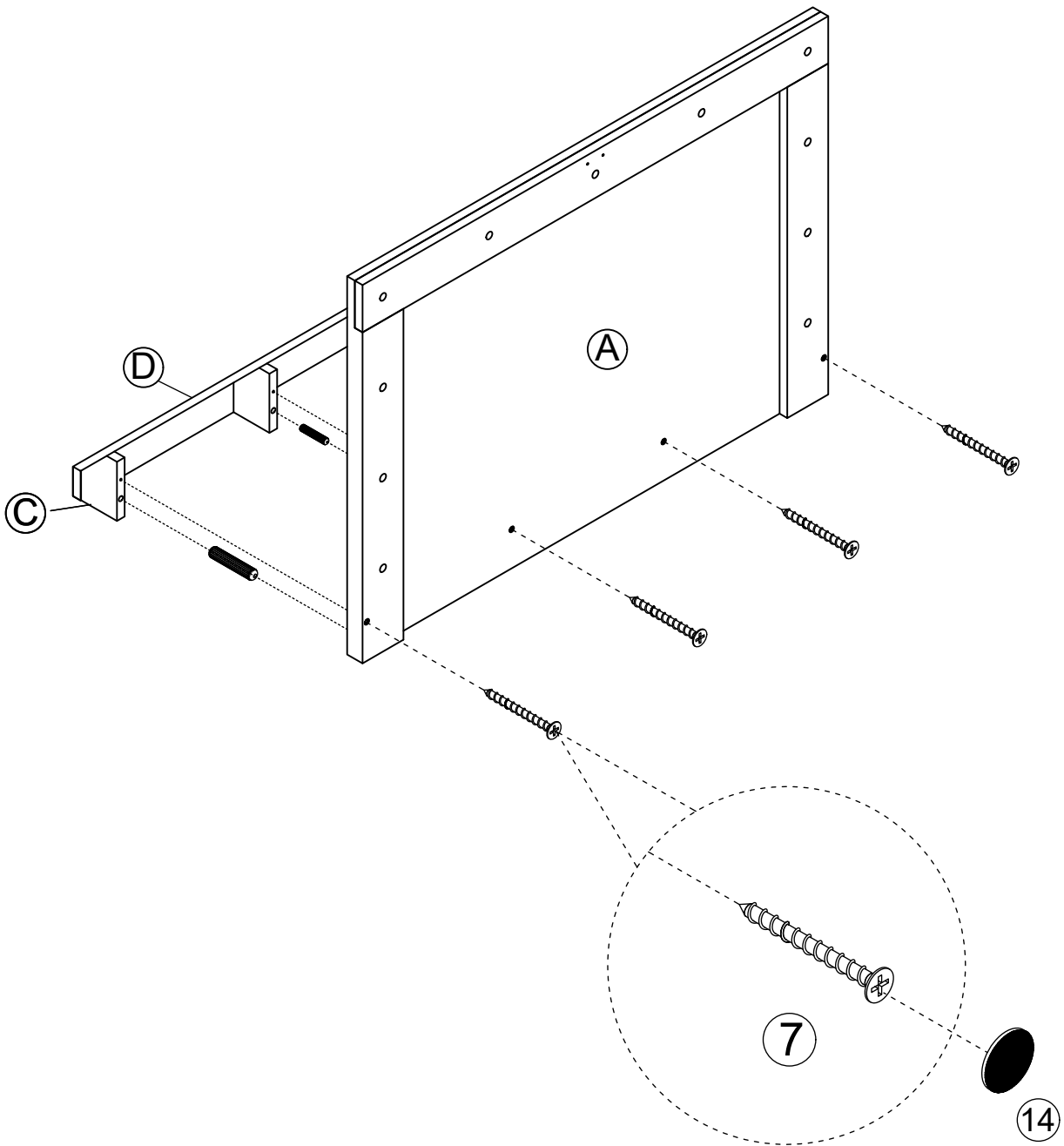
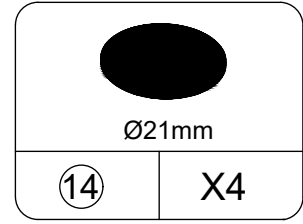
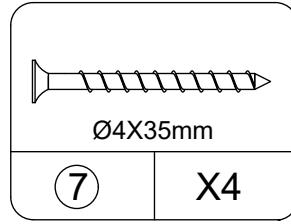
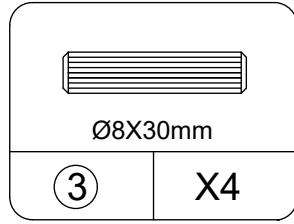
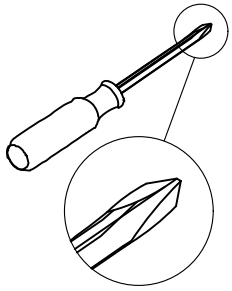

# STEP14

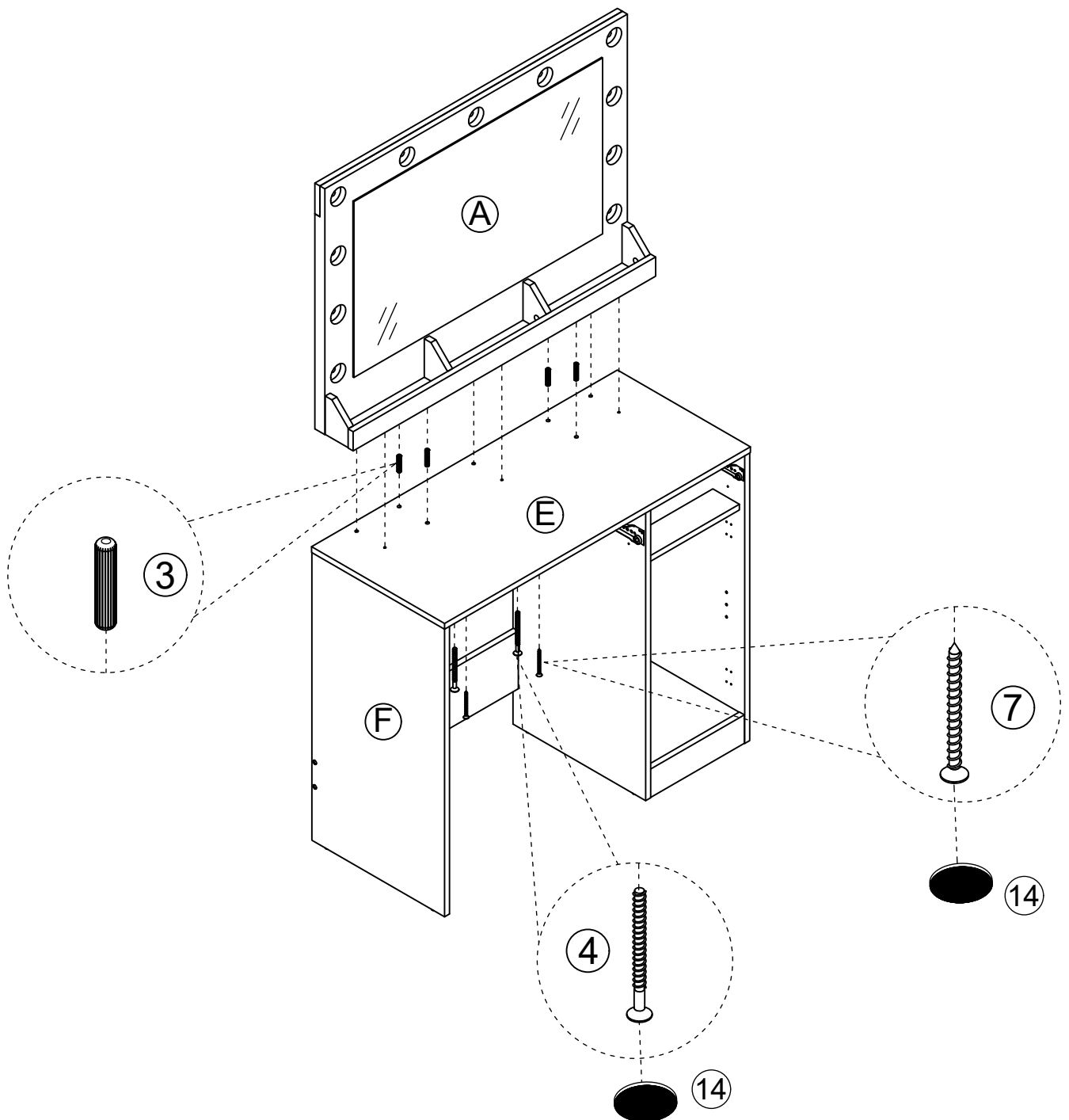
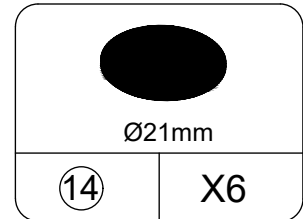
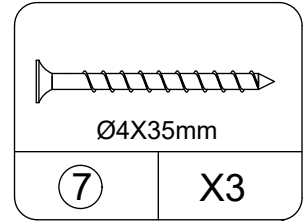
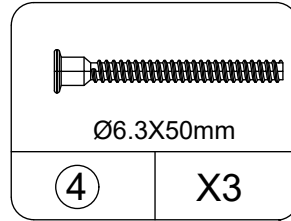
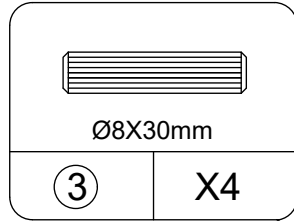
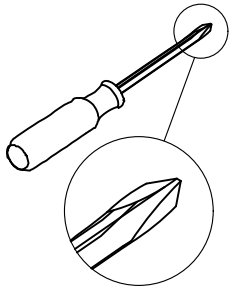

# STEP15

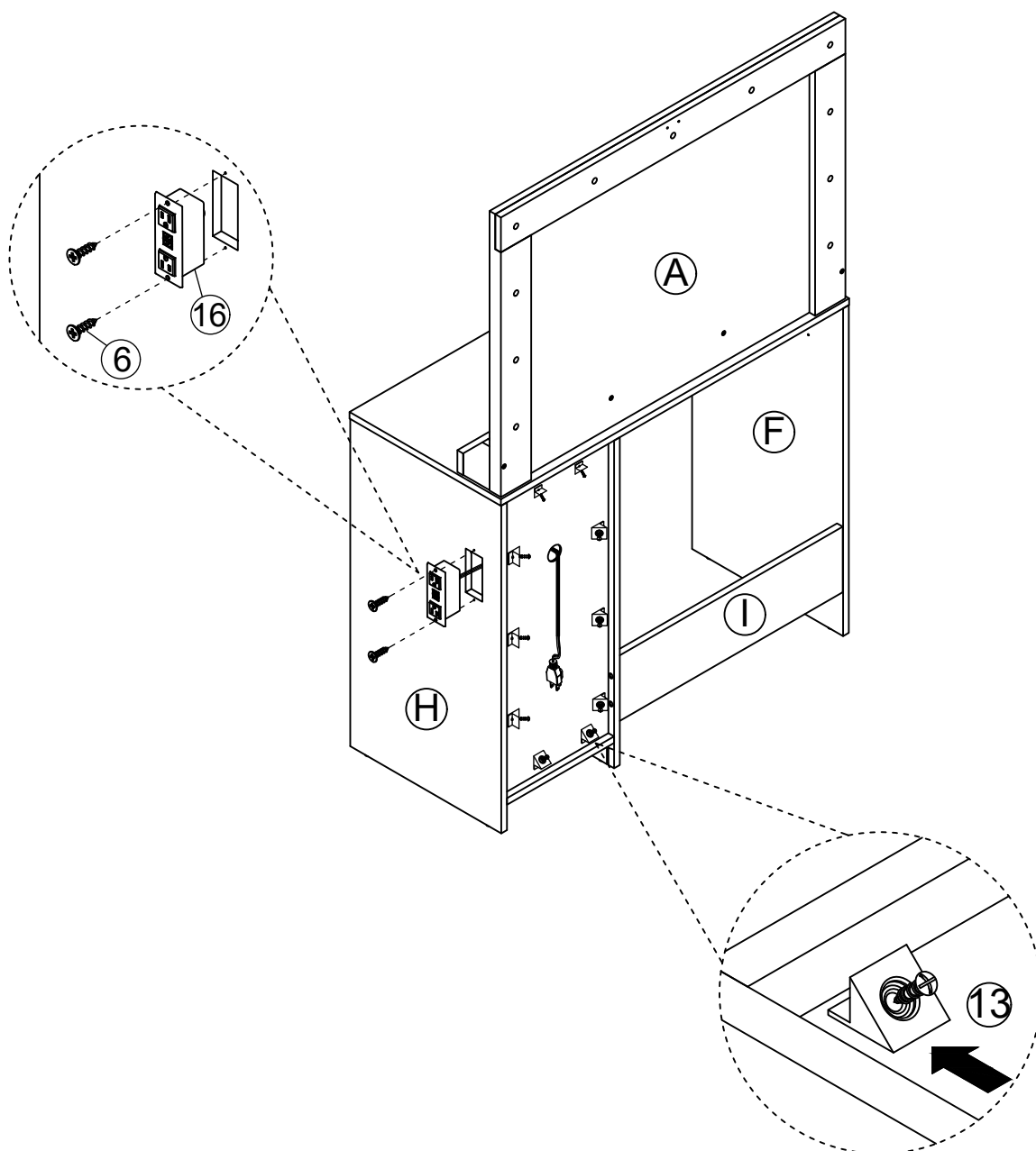
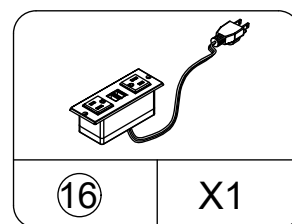
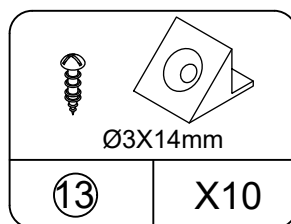
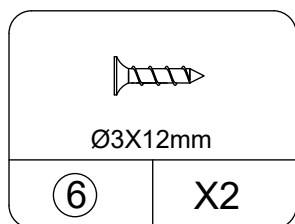
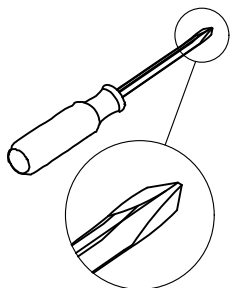

Insert the plastic buckle into the back plate slot, screw through the hole in the plastic buckle and lock it in place.

# STEP 16

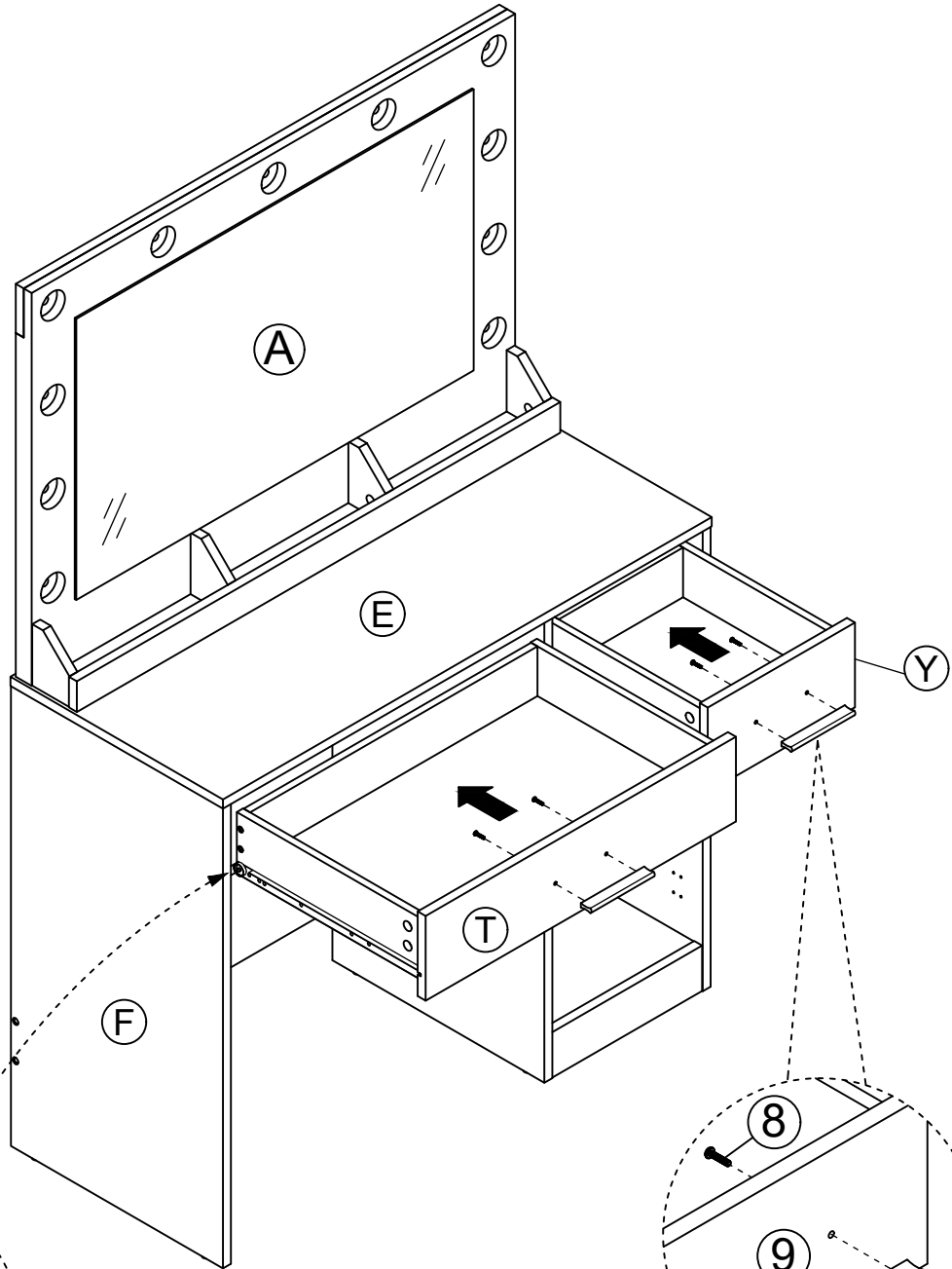
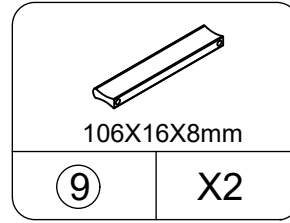
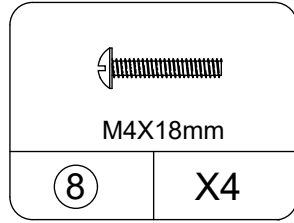
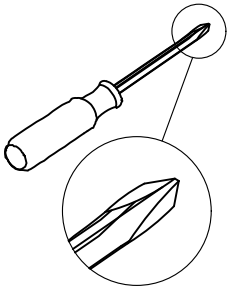

Cabinet Slide

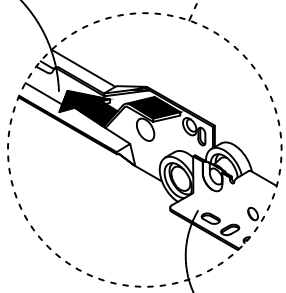

Drawer Slide

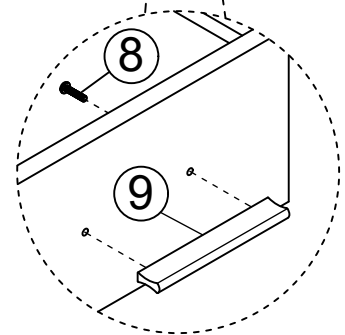

# STEP17

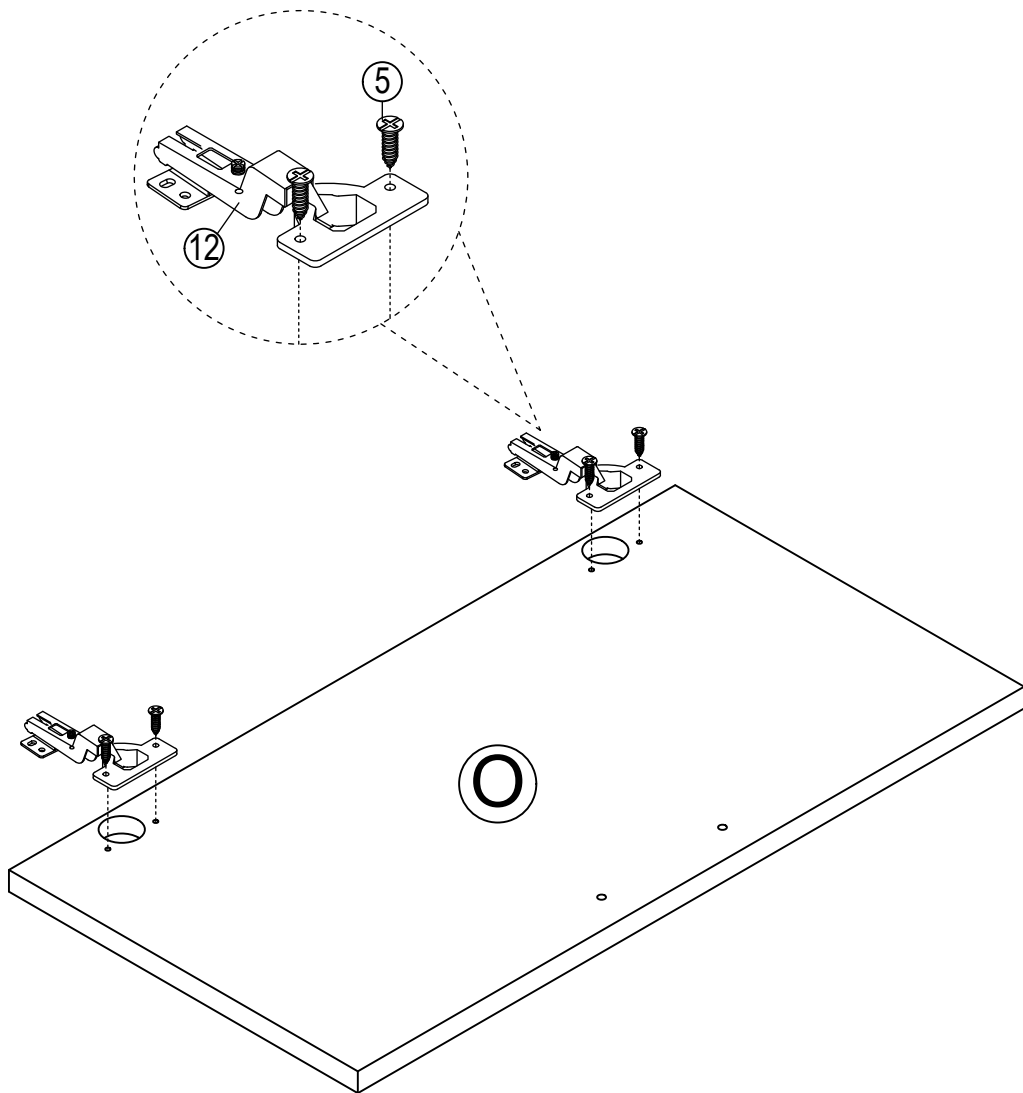
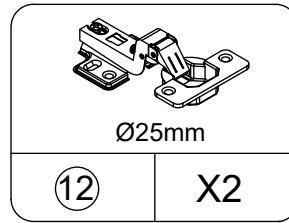
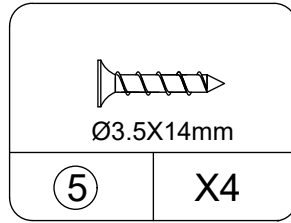
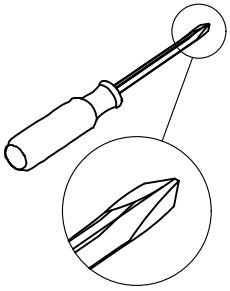

# STEP 18

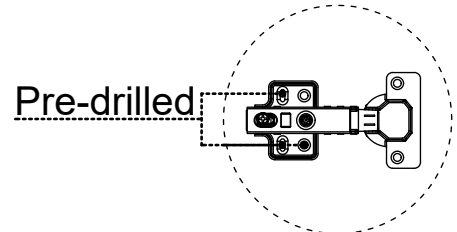
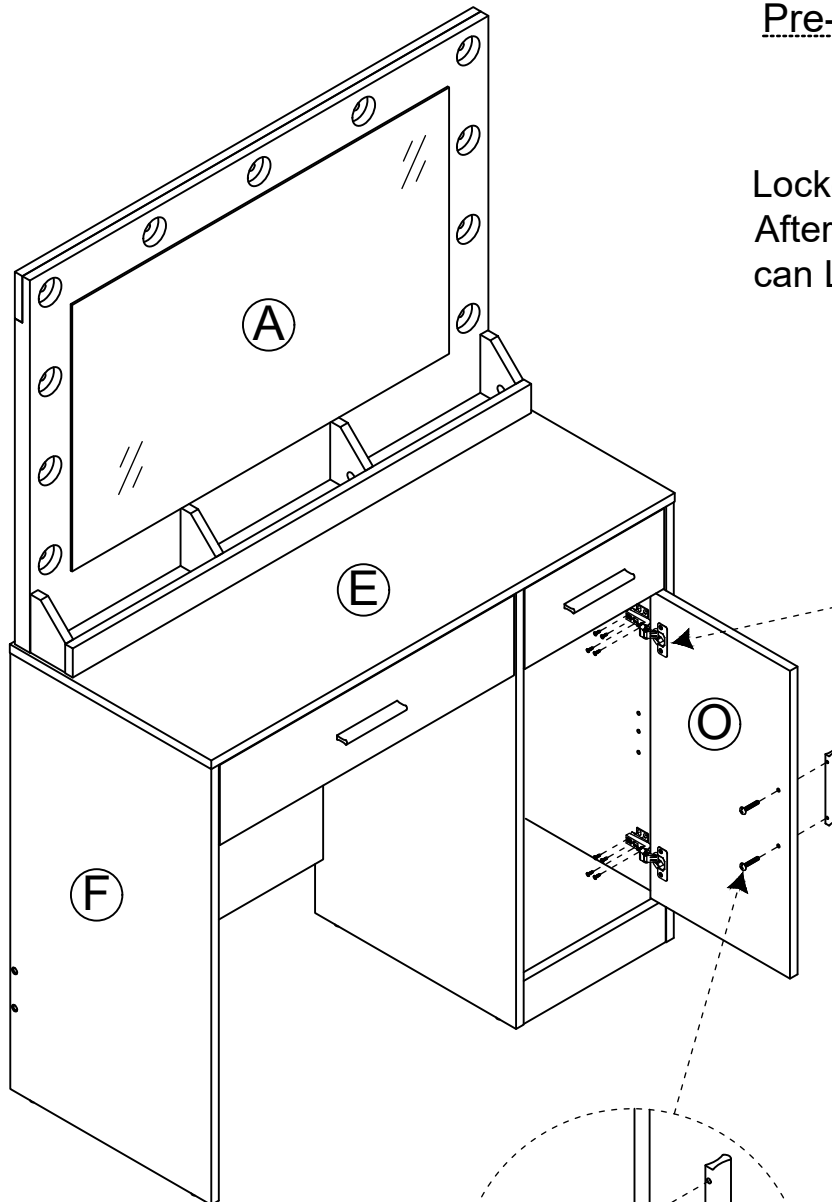
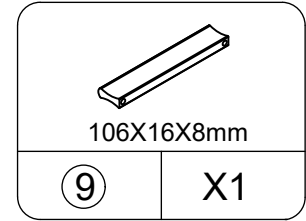
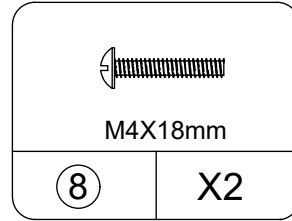
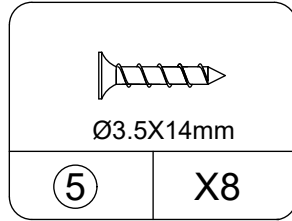
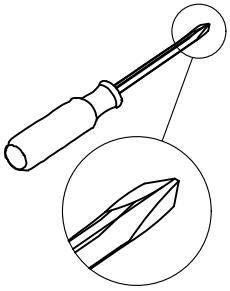

Locked with panel Pre-drilled.  
After you adjustable the gap, You  
can Locked the other three screws.

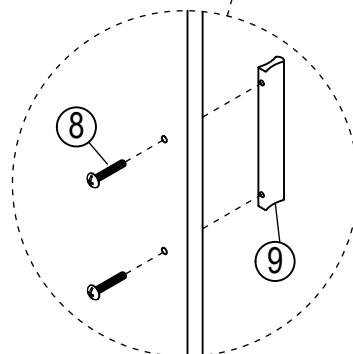
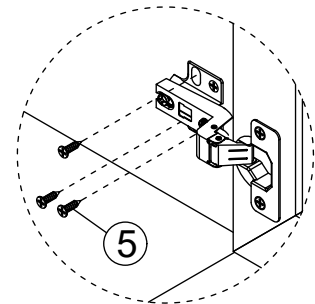
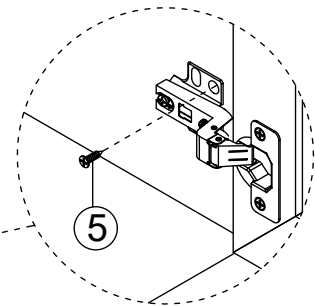

# STEP 19

---

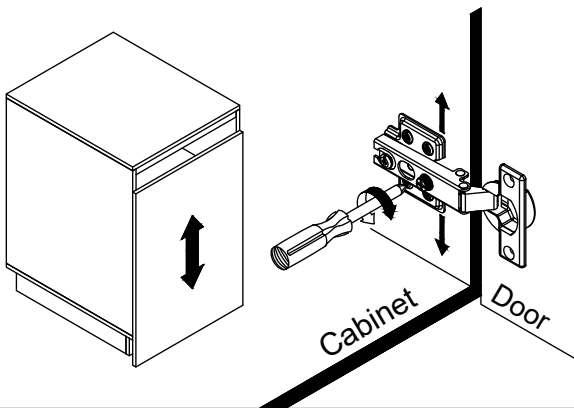
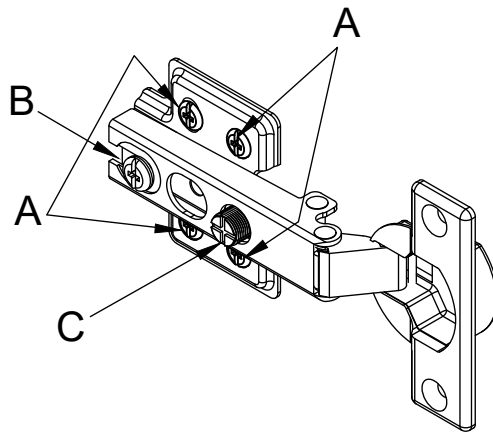

### To adjust the vertical height.

Loosen the four screws "A" on both hinges. Two of them are usually in slotted holes which allows you to adjust up or down by a few mm. Then tighten back up.

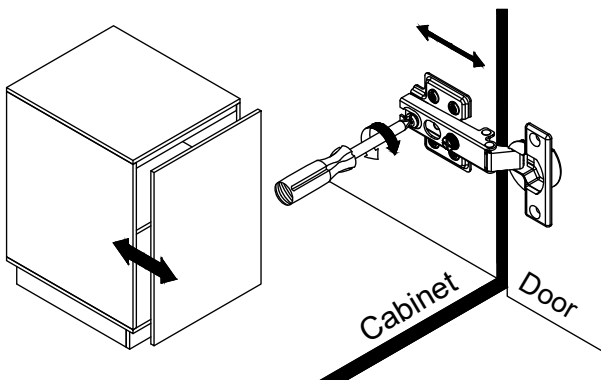

### To adjust depth.

Loosen screw "B" and adjust door, if the door can not be adjusted, please loosen screw "C", then try again. Tighten screw "B" and "C".

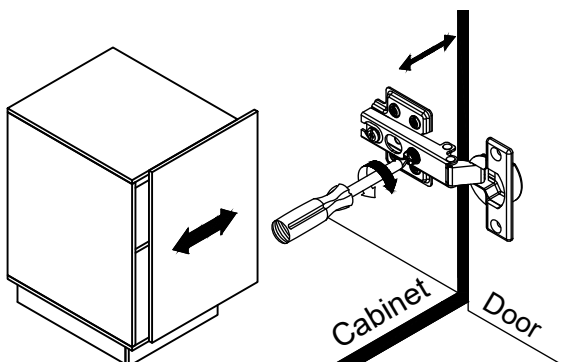

### To adjust side ways.

Turning the screw "C" on BOTH hinges on each door.

# STEP20

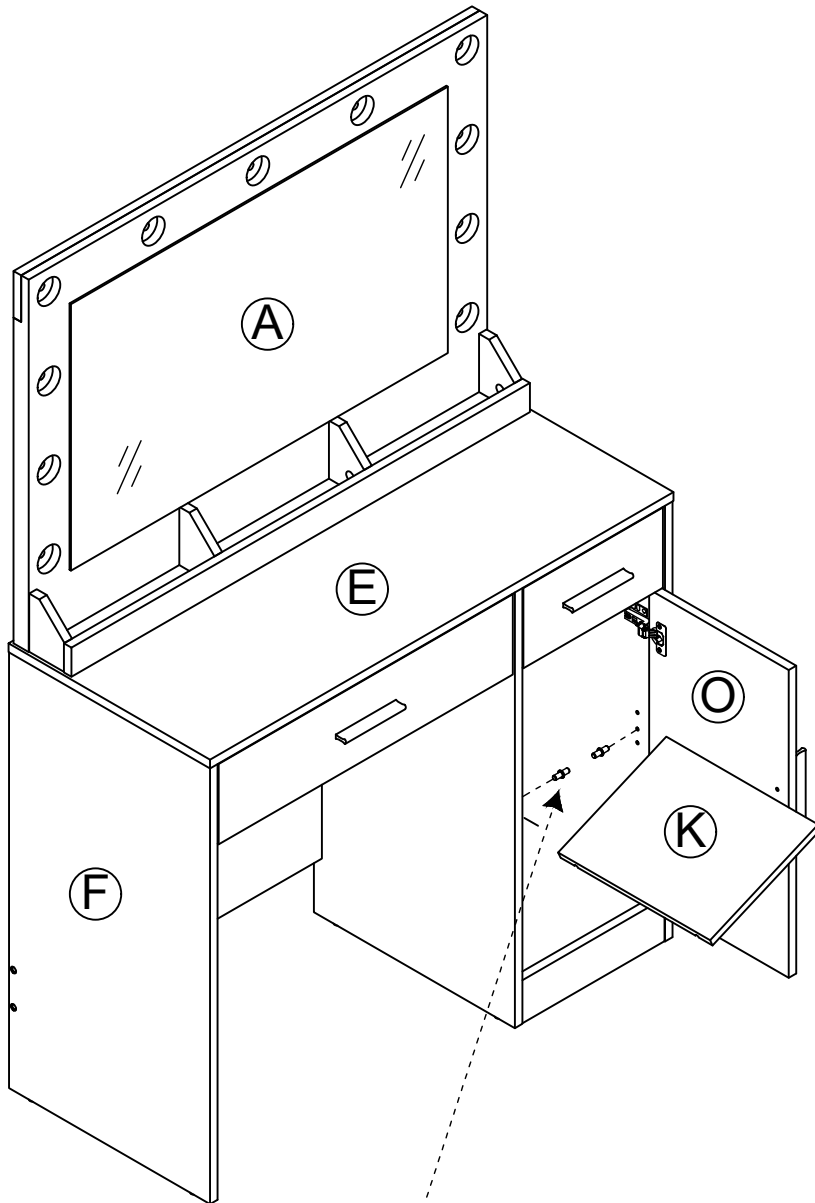
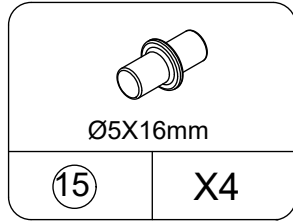

Step 1  
Select the desired height  
and put it in

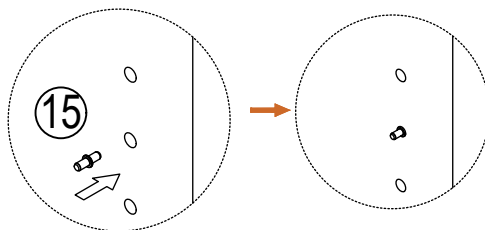

Step 2  
Aim the board gaps down

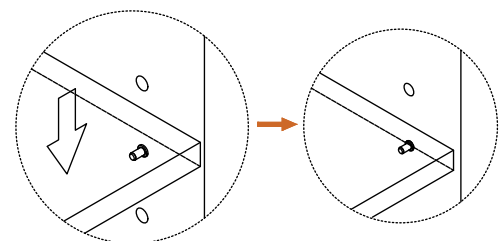

# STEP21

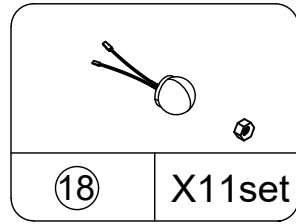
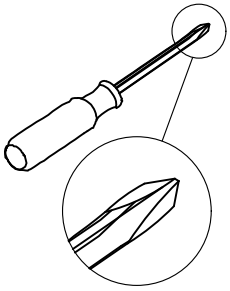

Thread the bulb wire through the pre-punched plate and tighten it with a plastic nut.

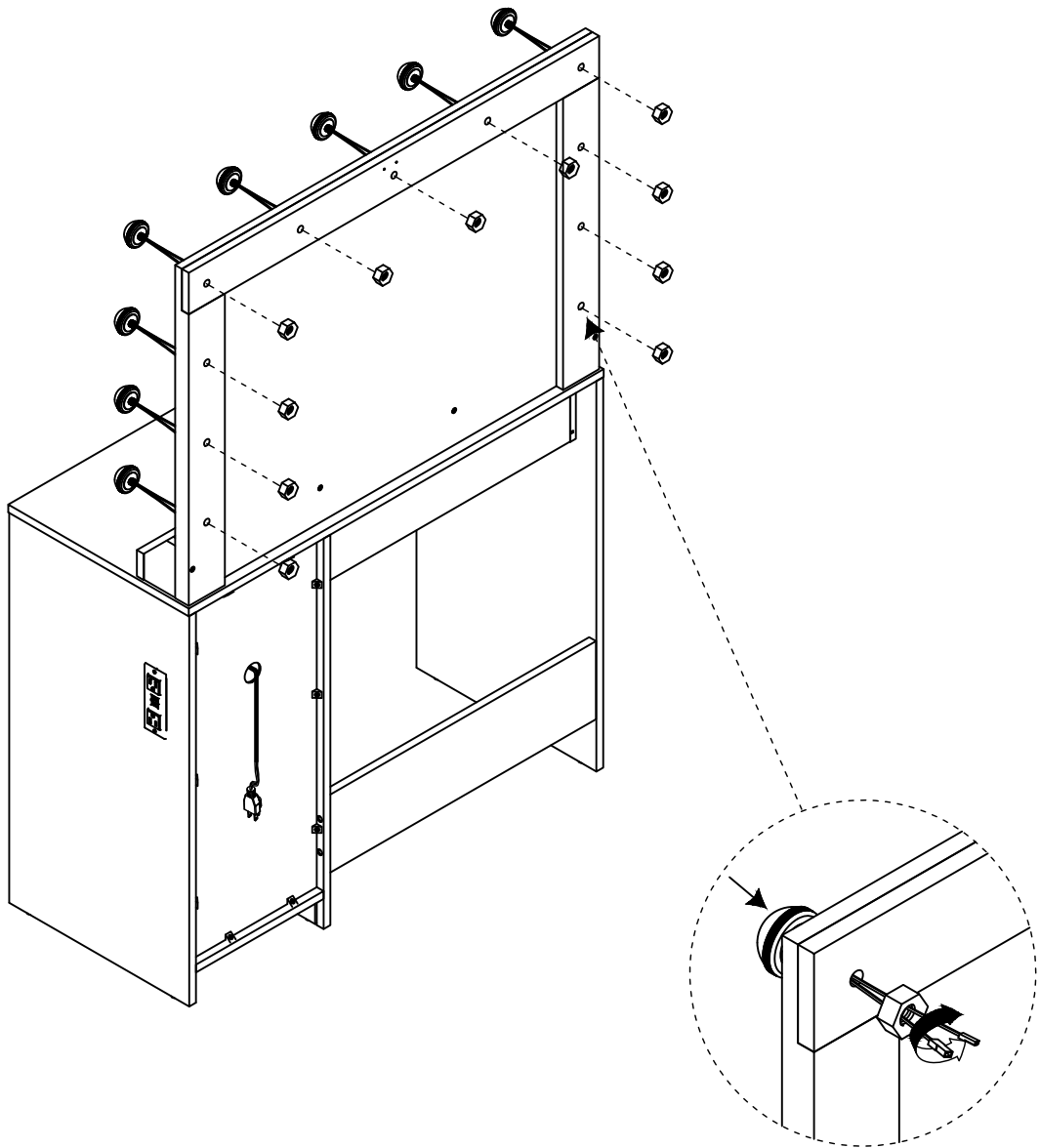

# STEP22

Pass the bulb wire through the pre punched plate, then gently press the bulb and make it adhere to the plate, and then connect the adjacent bulbs successively through the wire head slot on the opposite side (corresponding to the line of the same color).

When connecting the interface, please note that the colors of the wires at both ends correspond one by one.

same color correspond

press one end to unplug the other port

**Switch regulator**

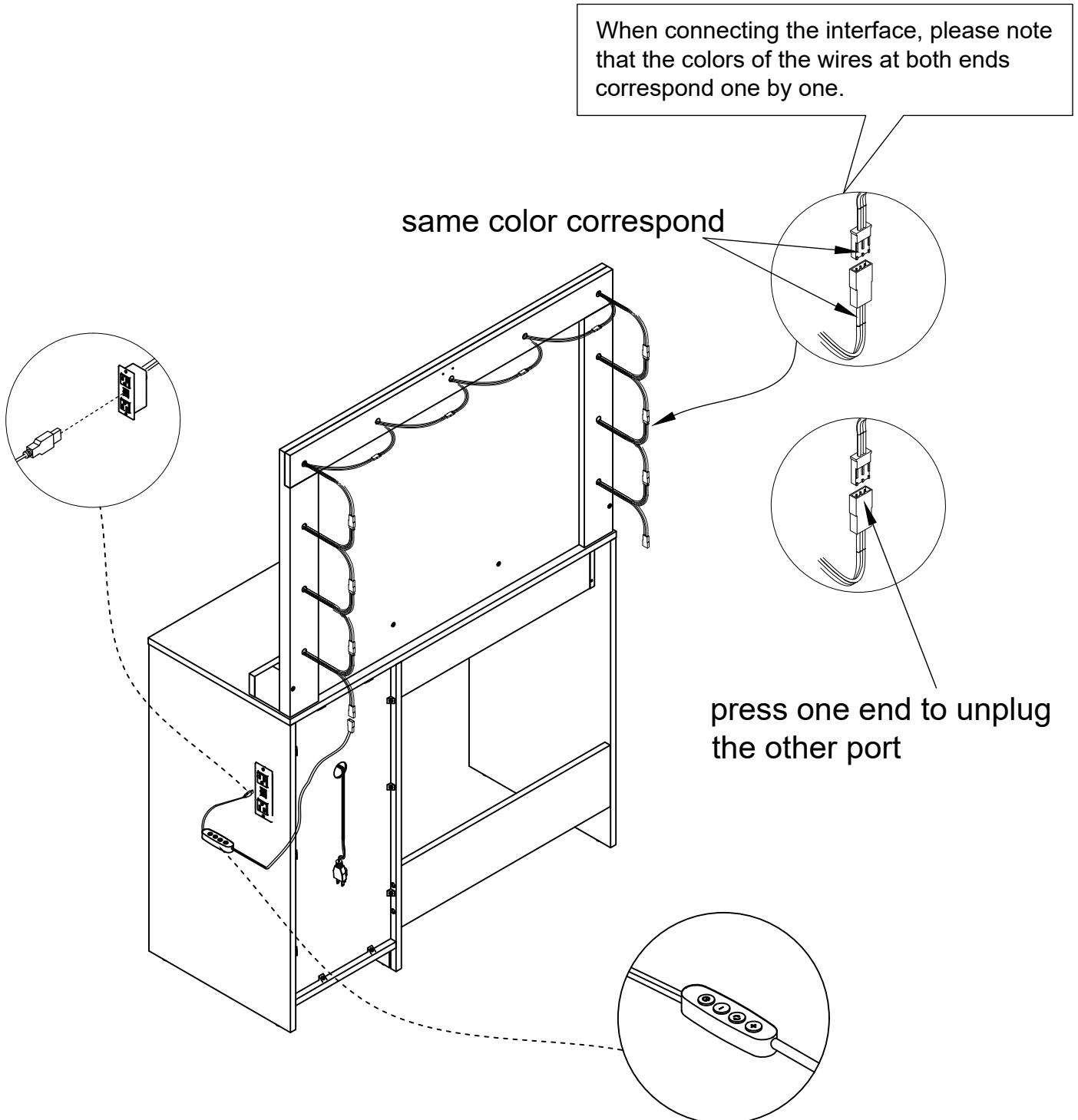

# STEP23

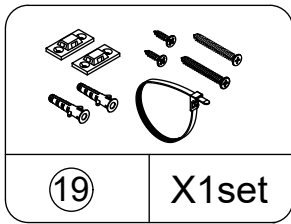

**NOTE:**The tipping restraint hardware included is for wooden stud wall construction. It must be attached to a wall stud. Depending upon your wall construction different anchor hardware maybe required. Please contact your local hardware store for assistance. Young children can be seriously injured by tipping furniture. You must install the tipping restraint hardware with the unit to prevent the unit from tipping, causing any accidents or damage. The tipping restraints are intended only as a deterrent and are not a substitute for proper adult supervision. The tipping restraints are not earthquake restraints. If you wish to add the extra security of earthquake restraints, they must be purchased and installed separately.

## Install the tipping restraint hardware

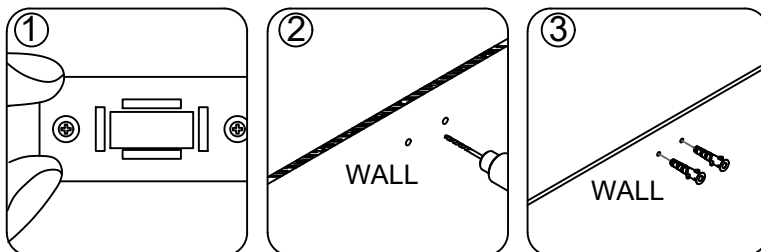

1. make mark on the wall

2. drill two Ø6 holes on the wall

3. put two anchors in the holes

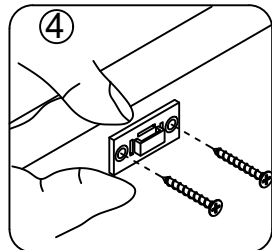

4. fix the device on the wall by the long screws

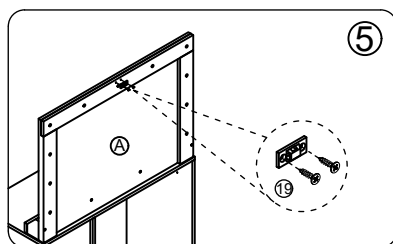

5. Use short screws to fix the device to the back of the cabinet.

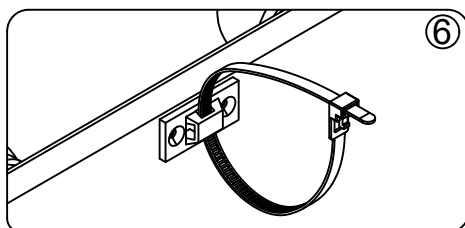

6. Push the cabinet close to the wall so that the two bases are close to each other, and then put on nylon tie to tighten it.

