

HAPPINESS HAPPINESS INSTALLATION

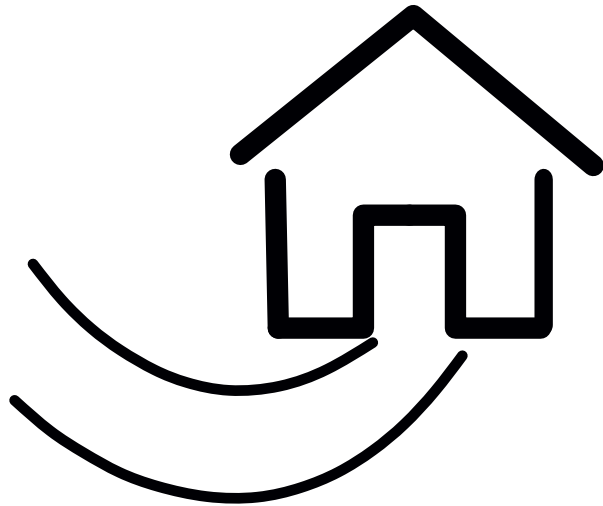

CAUTION

Parts are placed at the bottom of the product.

- If you have any questions with the product, please contact us by:
- **Email: customerservice@zoy-living.com**
(we will reply to you within 24 hours)



Assembly Instructions

CR0302AF71D

Your chair comes packaged in one box. Carefully remove all of components from the packaging and set aside for assembly.

CAUTION:
DO NOT use any sharp objects to open plastic wrapped components as damage to product or components may result

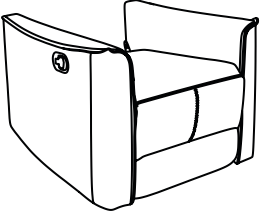
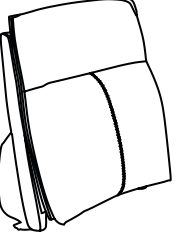
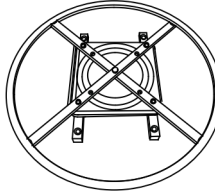
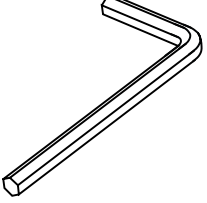
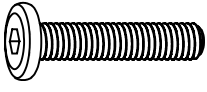
Package Contents

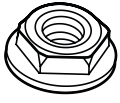
			
Part A*1 Seat Body	Part B*1 Backrest	Part C*1 Metal Wheel	Part D*1 Allen Wrench
			
Part E*4 Bolt	Part F*4 Black Spring Washer	Part G*4 Black Washer	Part H*4 Flanged Hex Nut

STEP 1

Locate Red Hardware Pack attached on the bottom of the Seat Body (A). Carefully separate the Metal wheel (C) from the bottom of the Seat Body (A).

Rotate the fixed base of Metal wheel (C) so that it is perpendicular to the V-shaped steel frame at the bottom of the seat, aligning the four holes on the fixed base with the holes marked by the arrow on the V-shaped steel frame.

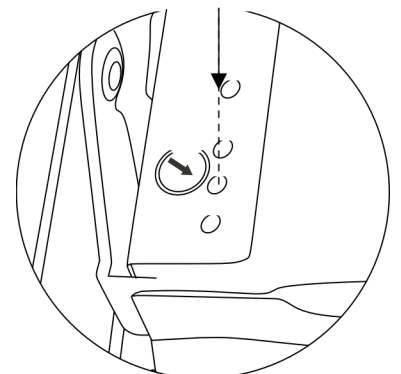
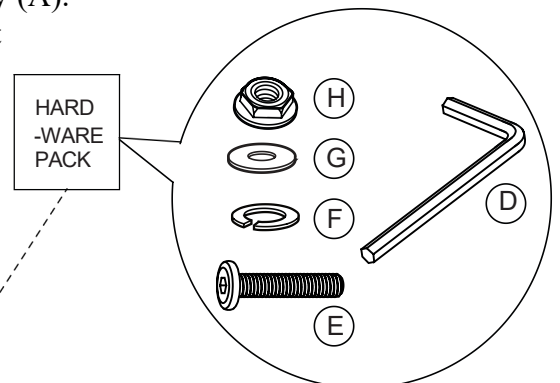
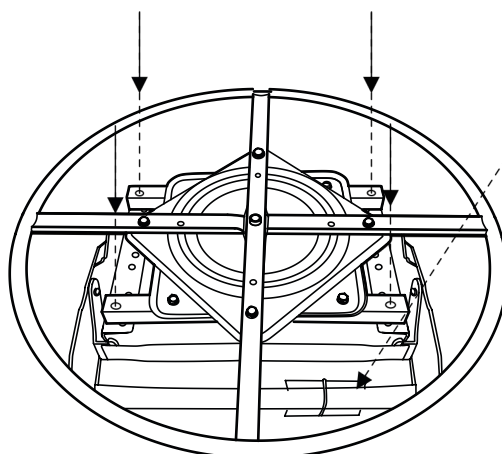

STEP 2

Please ensure all four Bolts (E) are fully tightened to secure the base before proceeding to the next step.

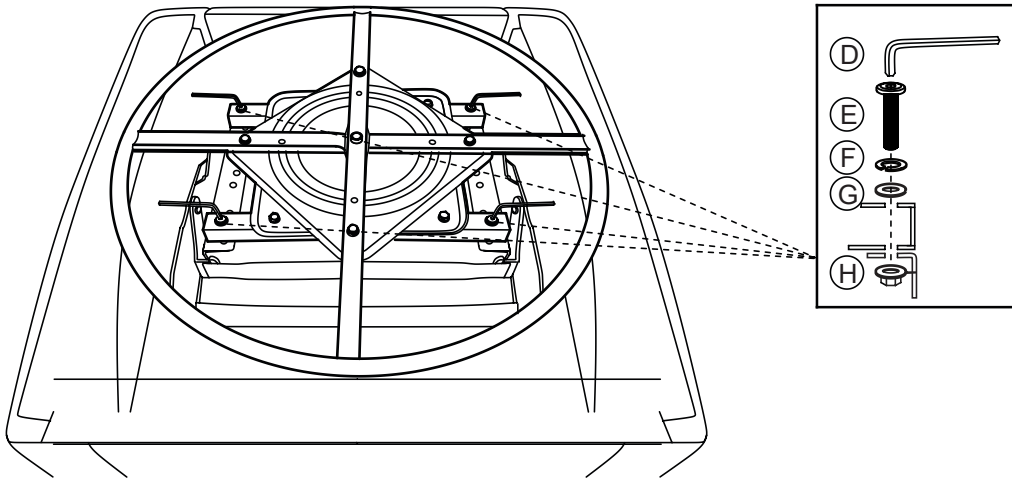

STEP 3

Attach **Backrest (B)** to **Seat Body (A)**.

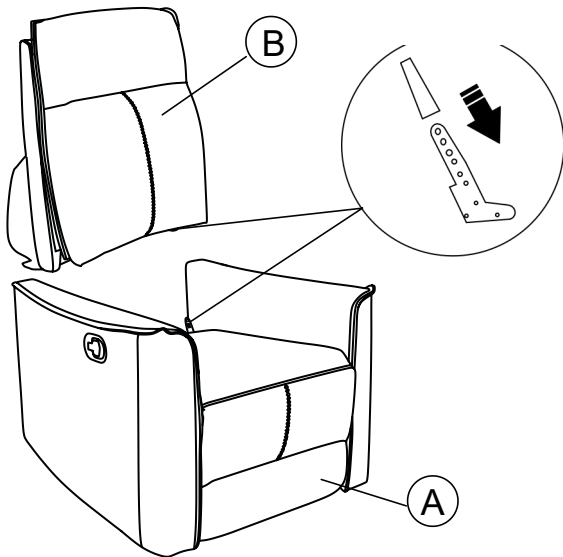

STEP 4

Assembly completed.

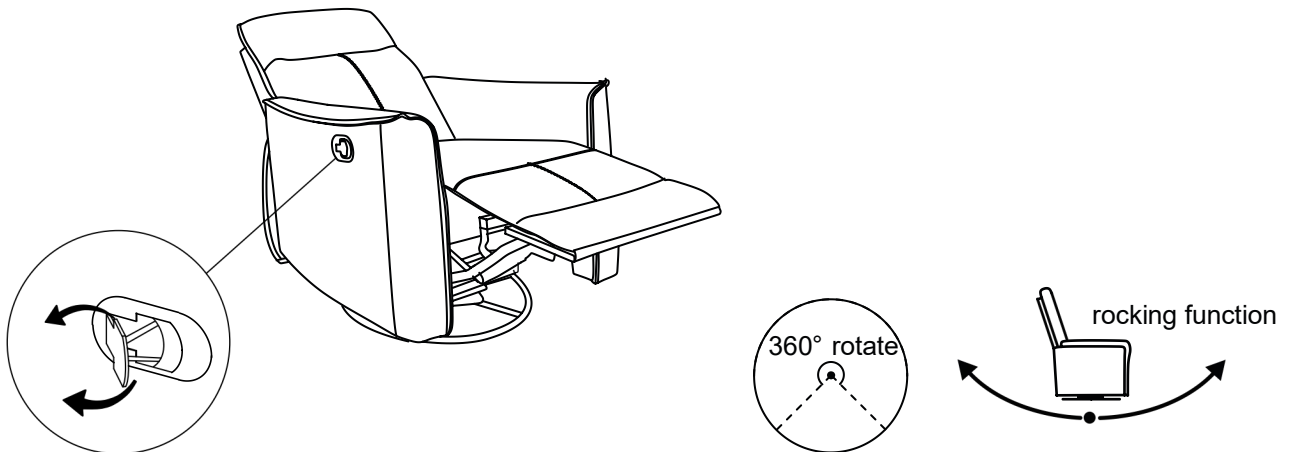
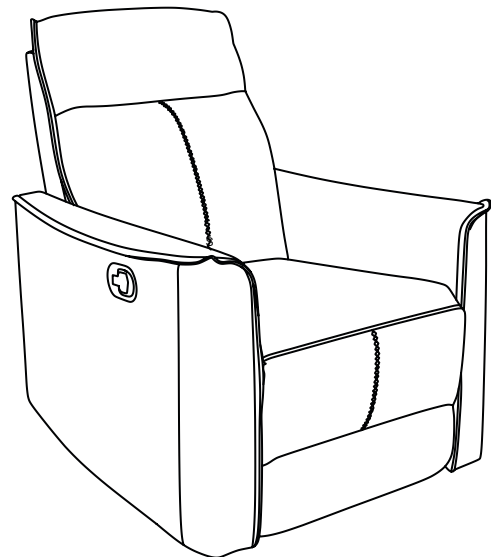

SIZE DIMENSIONS

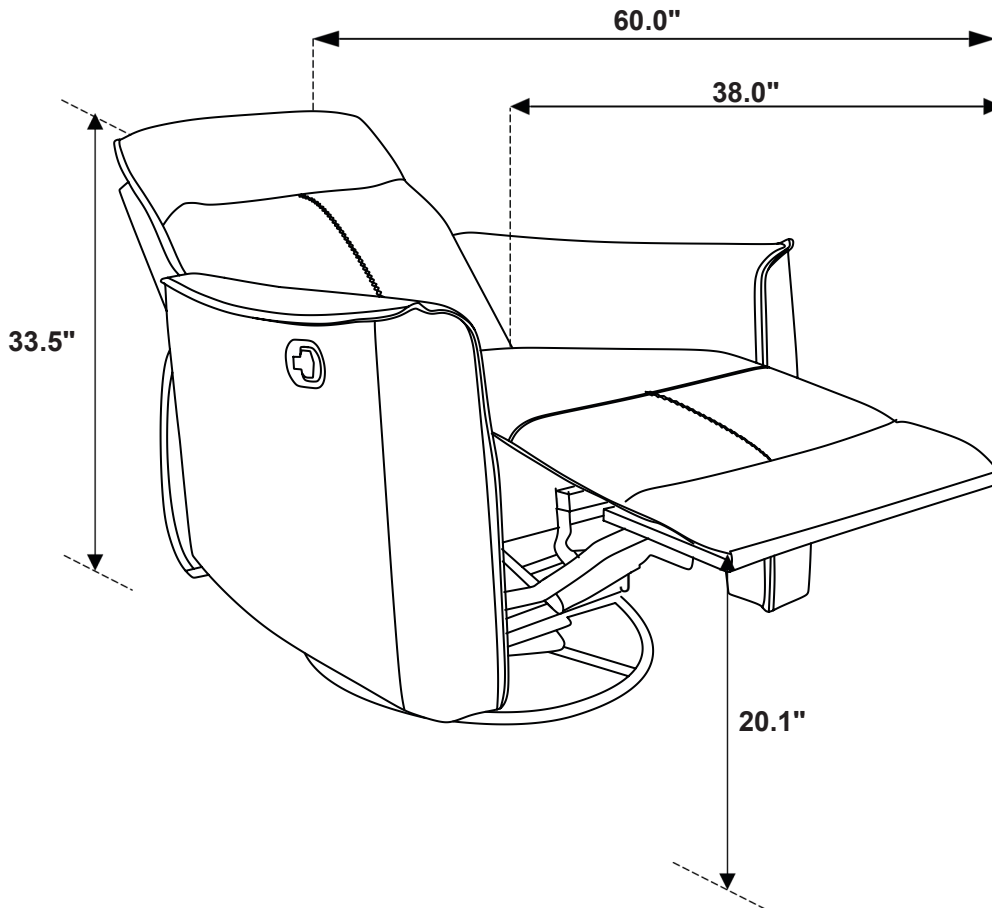
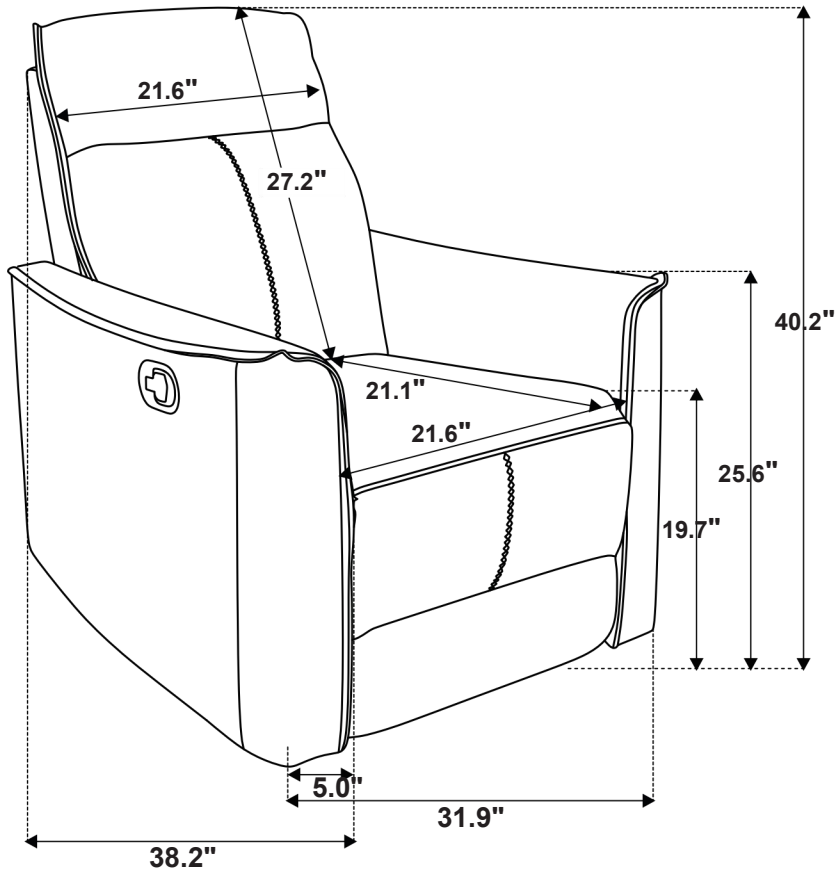

Warnings

1. Please check whether all components of the chair are included and in good condition.
2. Assemble all parts strictly following the instructions before connecting the chair to power.
3. DO NOT sit on the armrests or footrest to avoid the risk of tipping over.
4. If the chair is damaged or does not match the product description online, please send clear photos of the item and the shipping label to our customer service team.
5. If the recliner is not working, please try the following steps for troubleshooting:
 - a) Make sure all cables are properly connected;
 - b) Check whether the transformer indicator light is on.

If the chair still doesn't work, please feed the information back to our customer service in time and we'll help you solve the matter as soon as possible.

6. If you have any questions with the product, please contact us by:

Email: customerservice@zoy-living.com (we will reply to you within 24 hours)

