







Examine all packaging material for small parts that may have come loose during shipment. Periodic checks are recommended to insure that all components are in proper position, tight and free from damage. Keep this assembly instruction for future reference. Adult assembly is required.

HDFBP

CODE	QTY	HARDWARE	
1	28	1/4"*15 Allen Bolts	
2	28	Φ6.5*1.5 Spring Washers	
3	28	Φ13*Φ6.5*1.5 Flat Washers	
4	1	4*4 Allen Wrench	
5	2	1/4"*40 Allen Bolts	

CODE	QTY	COMPONENTS	CODE	QTY	COMPONENTS
A	1	Table Top 	B	2	Leg Panels 
C	1	Bottom Rail 	D	2	Top Rails 
			E	2	Support Bars 

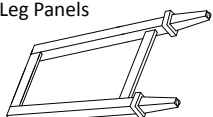
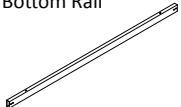
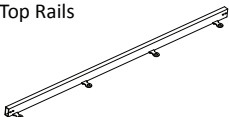
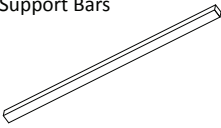
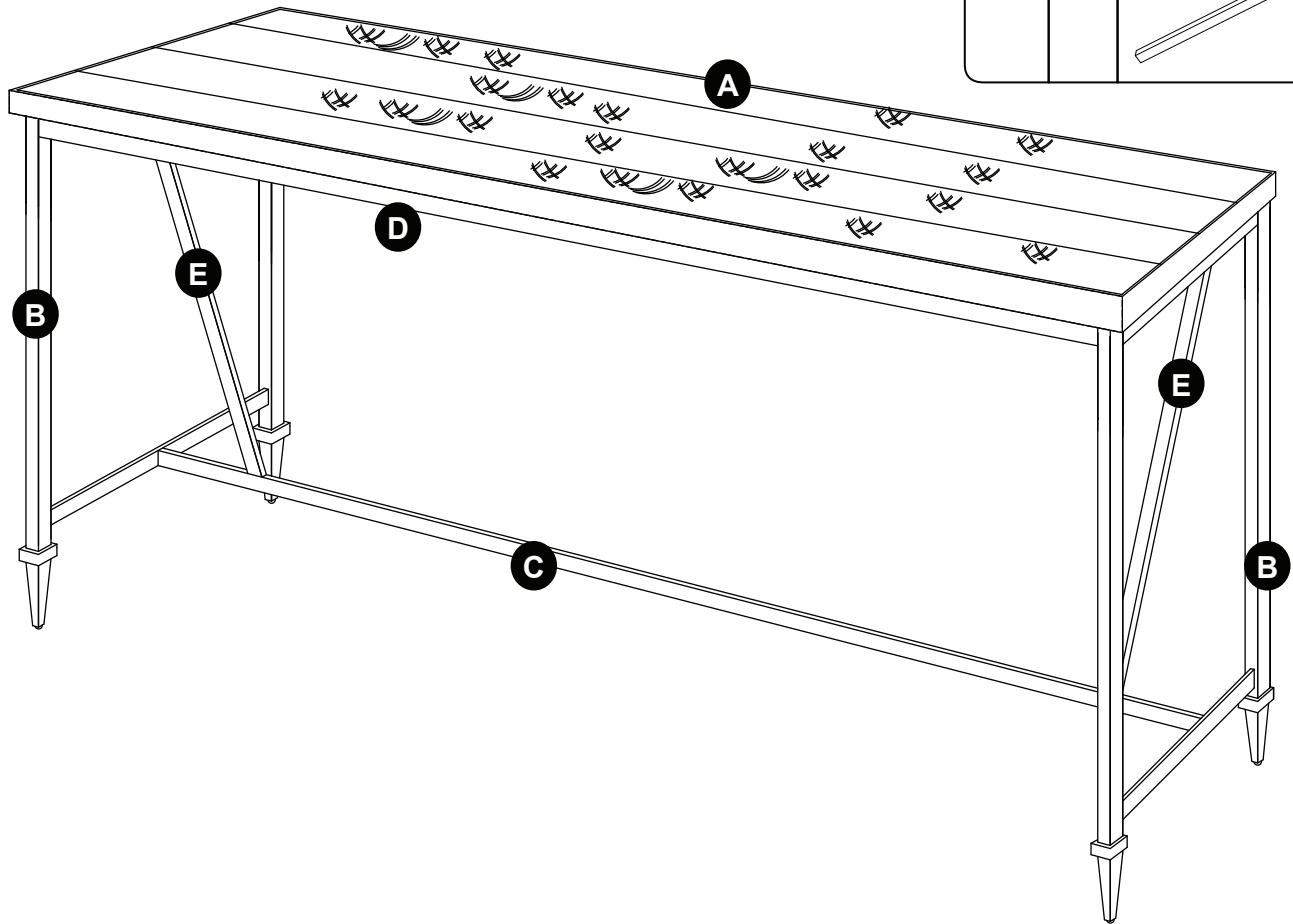

WARNING

- Do not let any sharp objects touch or rub the surface of the product.
- When assembling, do not let children play around the working area.
- Please confirm all parts are correct before starting the assembly process.
- Do not tighten all bolts and screws completely until the entire unit has been assembled and set up.
- Be careful if using power tools as they can over tighten screws and strip threads.

CARE & MAINTENANCE: The touch of a soft cloth is all the maintenance the finish will ever need. Please do not use harsh or abrasive cleaners for polishing, as they may cause damage to the finish. Periodic checks are recommended to make sure that all hardware is securely tightened.

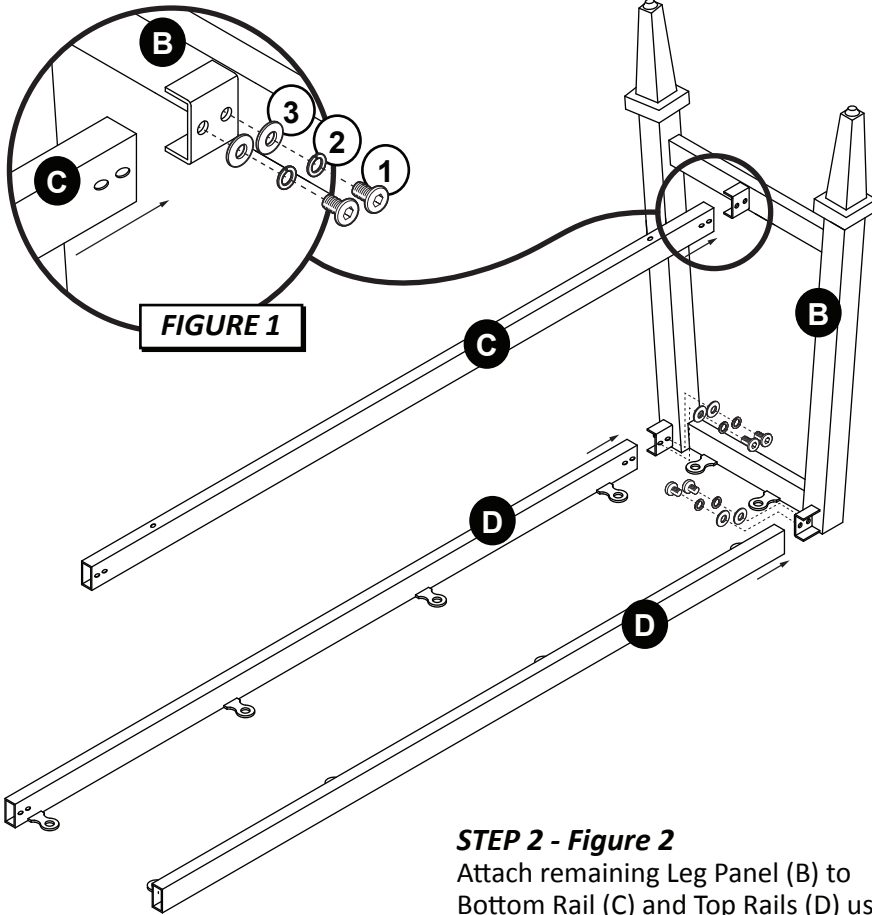

STEP 1 - Figure 1

Begin assembly by attaching Top Rails (D) and Bottom Rail (C) to one Leg Panel (B) using 2 Allen Bolts (1), 2 Spring Washers (2) and 2 Flat Washers (3) per rail.

STEP 2 - Figure 2

Attach remaining Leg Panel (B) to Bottom Rail (C) and Top Rails (D) using 2 Allen Bolts (1), 2 Spring Washers (2) and 2 Flat Washers (3) per rail.

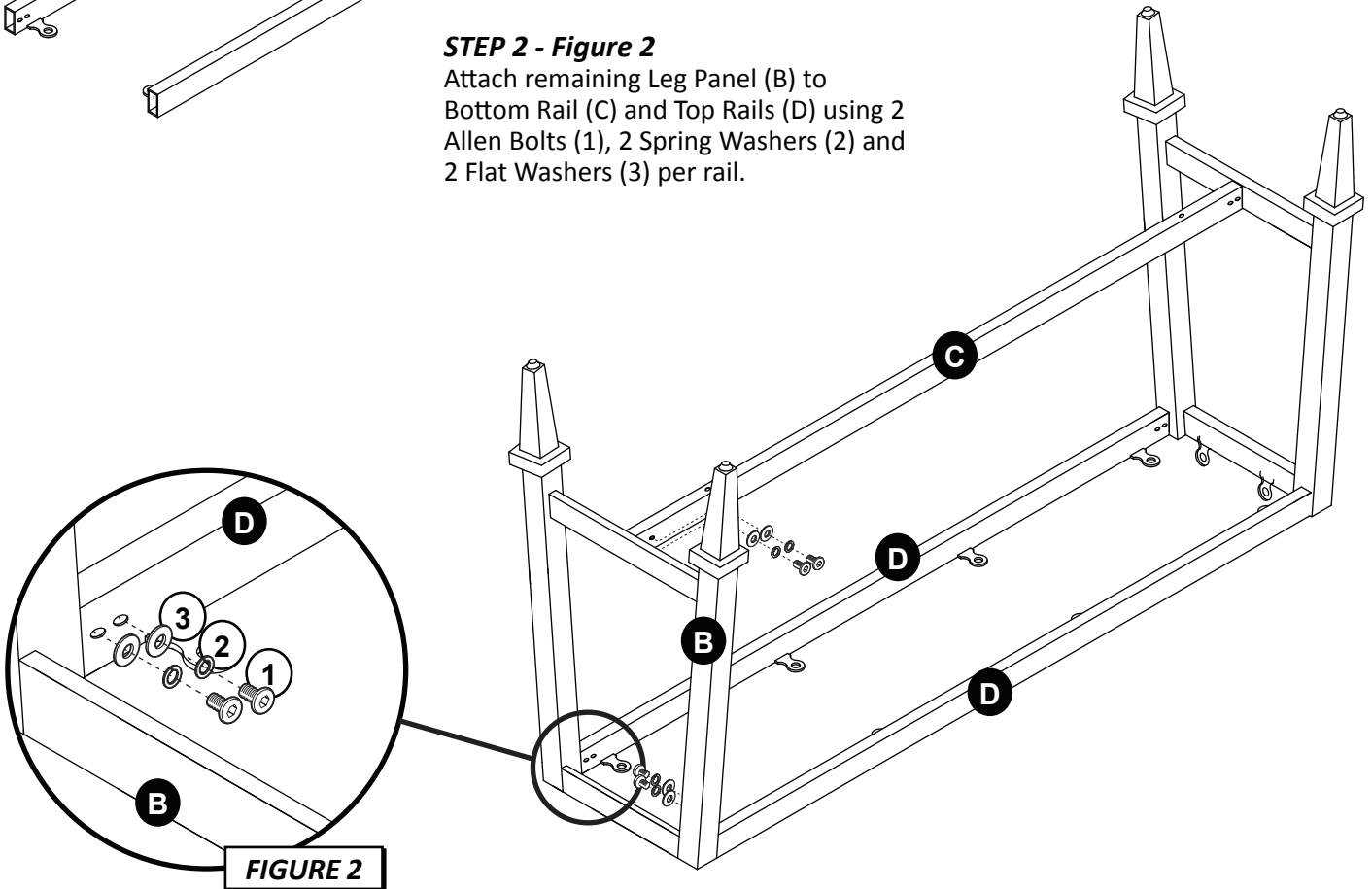

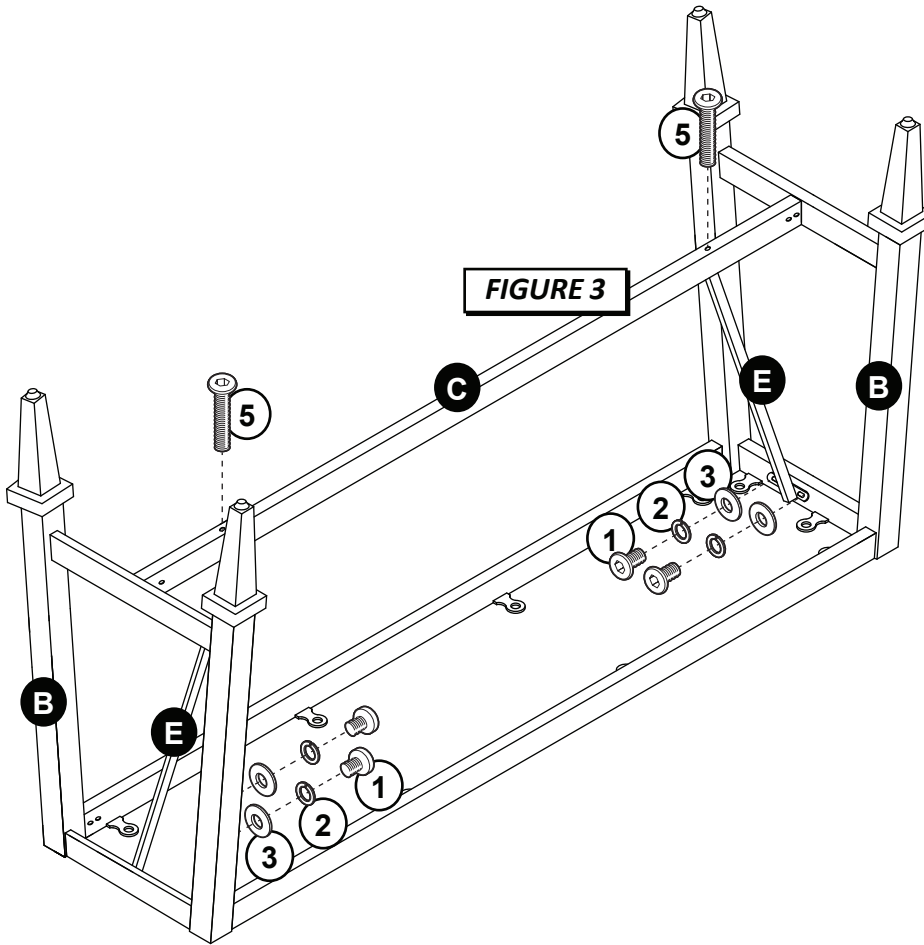

FIGURE 3

STEP 3 - Figure 3

Attach Support Bars (E) to inside top of Leg Panels (B) using 2 Allen Bolts (1), 2 Spring Washers (2) and 2 Flat Washers (3) per bar. Secure other end of Support Bars (E) to Bottom Rail (C) using 1 Allen Bolt (5) per rail.

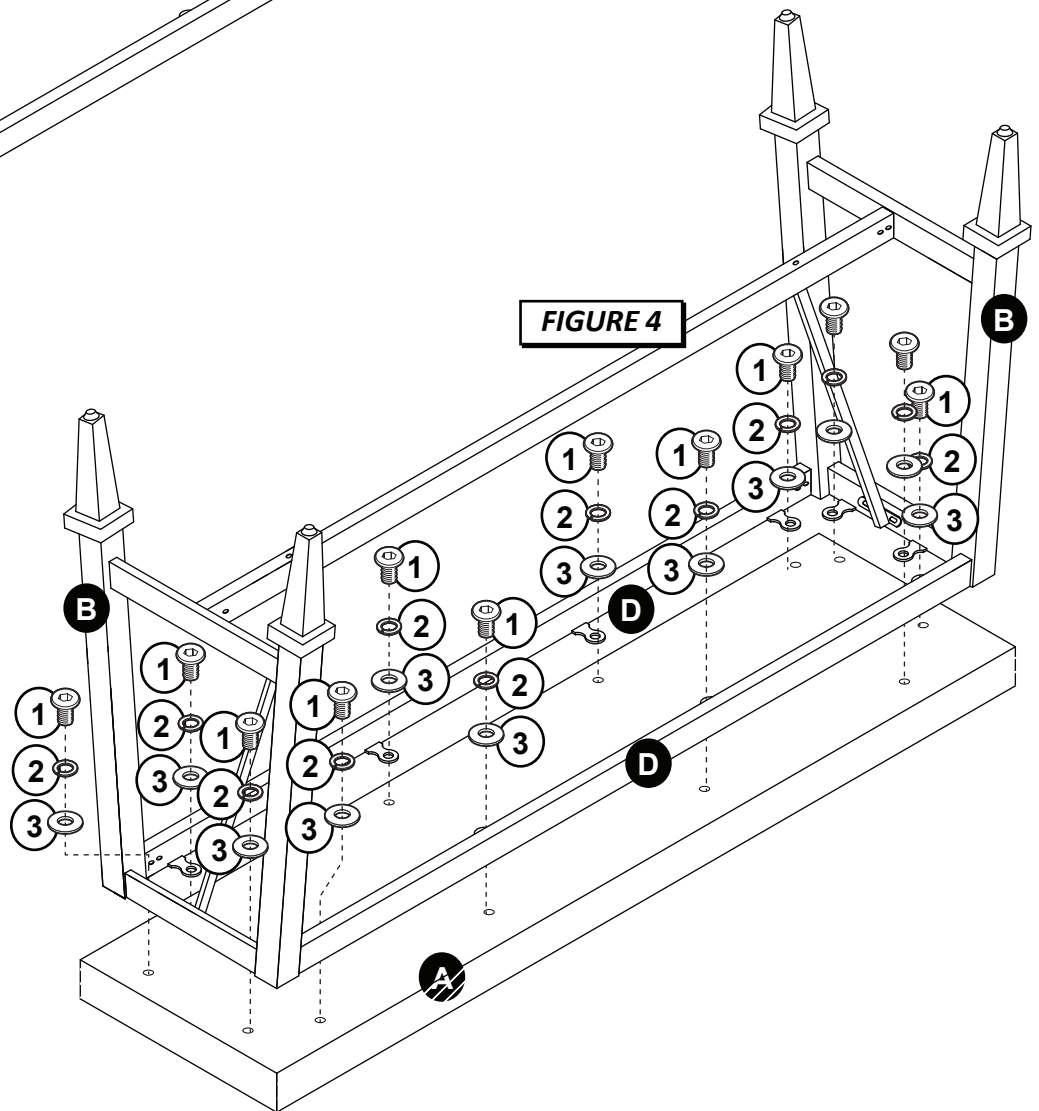

FIGURE 4

STEP 4 - Figure 4

Attach Leg Panels (B) and Top Rails (D) to Table Top (A) using 12 Allen Bolts (1), 12 Spring Washers (2) and 12 Flat Washers (3). Tighten all bolts using Allen Wrench (4) provided. The assembly is now complete.