

ASSEMBLY INSTRUCTIONS



WRITING DESK

ASSEMBLY INSTRUCTIONS

ASSEMBLY TIPS:

1. Remove hardware from box and sort by size.
2. Please check to see that all hardware and parts are present prior to start of assembly.
3. Please follow attached instructions in the same sequence as numbered to assure fast & easy assembly.



WARNING!

1. Don't attempt to repair or modify parts that are broken or defective. Please contact the store immediately.
2. This product is for home use only and not intended for commercial establishments.

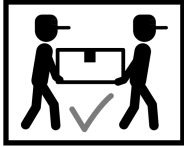

ASSEMBLY TIME 30 MINUTES

PARTS IDENTIFICATION

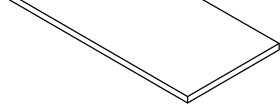
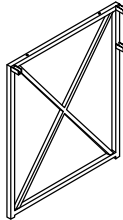
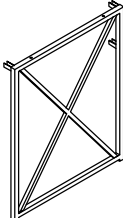
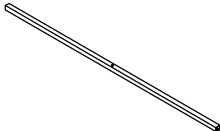
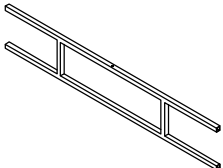
A	TOP		1PC
B	LEFT FRAME		1PC
C	RIGHT FRAME		1PC
D	FRONT CROSSBAR		1PC
E	BACK FRAME		1PC

ASSEMBLY INSTRUCTIONS

HARDWARE IDENTIFICATION

1	SHORT BOLT (ϕ 1/4 x 12mm SR)		12PCS
2	LONG BOLT (ϕ 1/4 x 32mm SR)		6PCS
3	CAP (20 x 20mm BLK)		4PCS
4	ALLEN WRENCH (4mm)		1PCS

ASSEMBLY INSTRUCTIONS

STEP 1 Do not tighten until each step is completed or instructed.

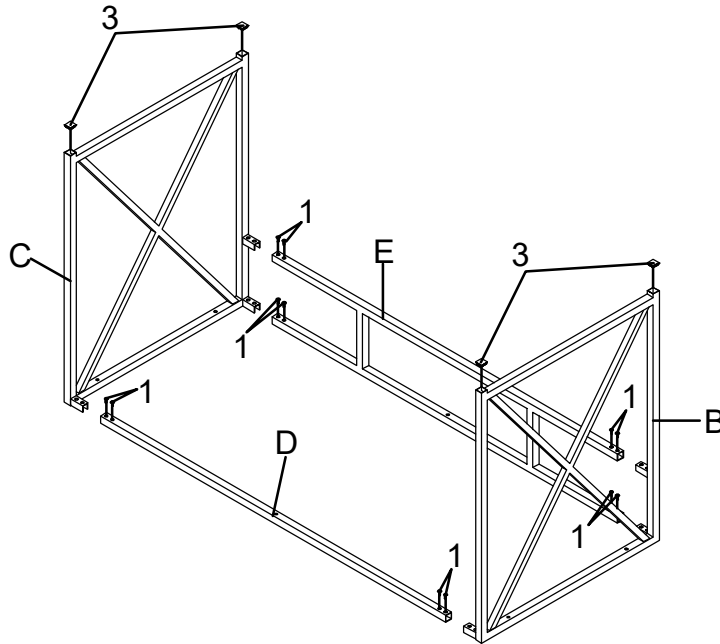

STEP 2

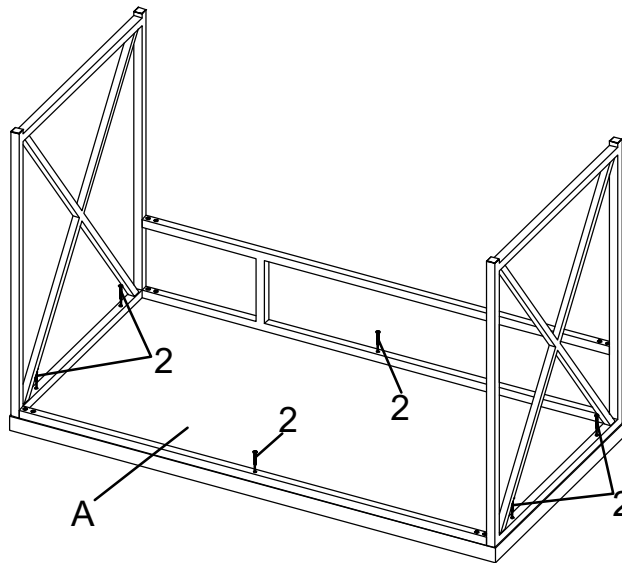

COMPLETE

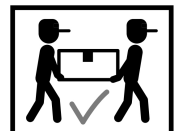
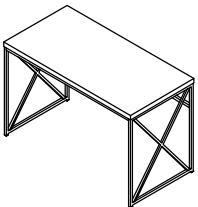

ASSEMBLY INSTRUCTIONS

Product Size : 1200 X 597 X 762 H (MM)
Product Size : 47 $\frac{1}{4}$" X 23 $\frac{1}{2}$" X 30"

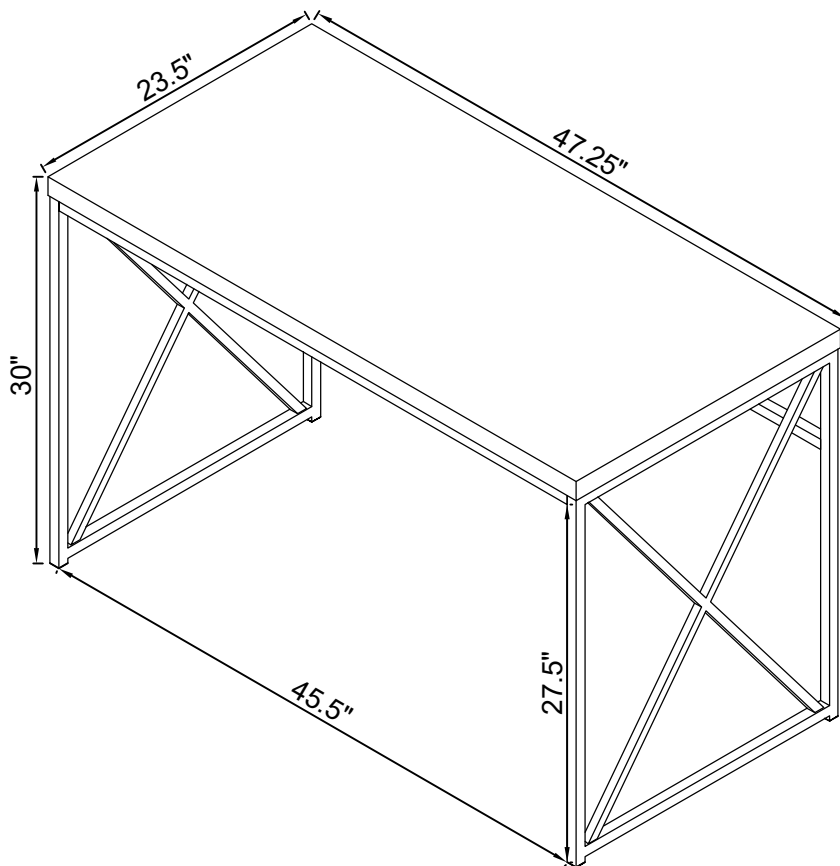

Note : Dimension tolerance $\pm 5\%$