

# Coffee Table

Thank you for purchasing this quality product. Be sure to check all packing material carefully for small parts that may have come loose inside the carton during shipment.

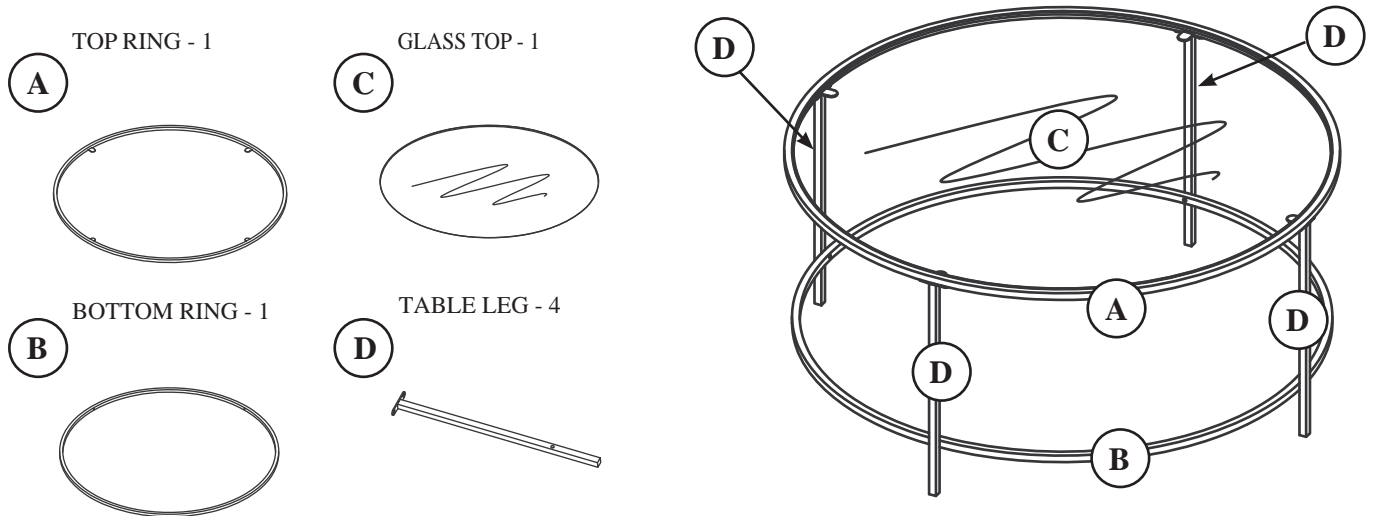

## PART/HARDWARE IDENTIFICATION:

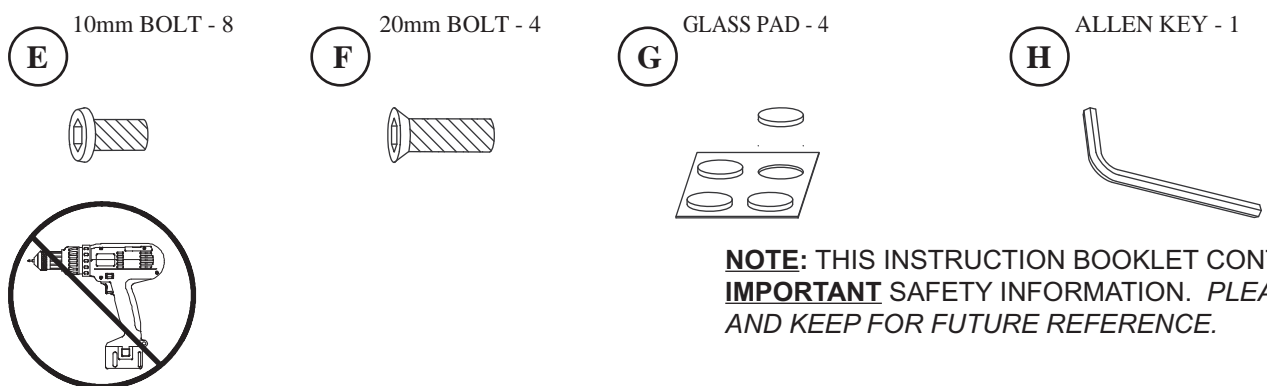

**NOTE:** THIS INSTRUCTION BOOKLET CONTAINS **IMPORTANT** SAFETY INFORMATION. PLEASE READ AND KEEP FOR FUTURE REFERENCE.

1

Do not tighten the screws until assembly is complete.  
Ne pas serrer les vis avant d'avoir terminé l'assemblage.  
No apriete los tornillos hasta que el montaje esté completo.

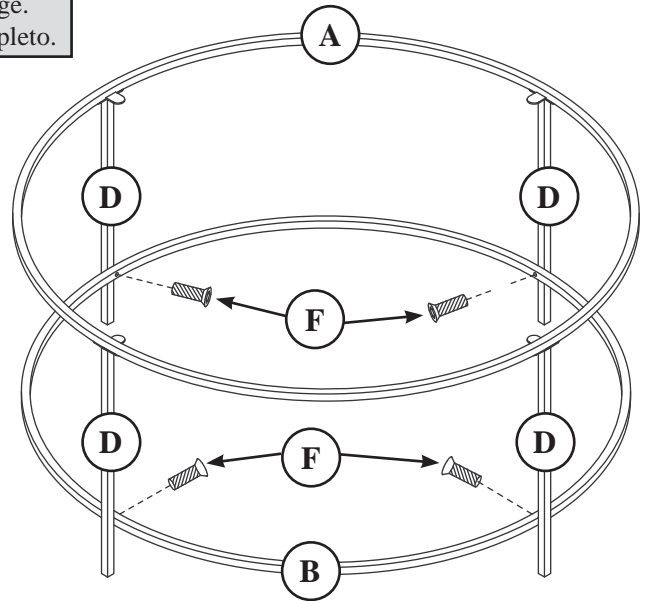
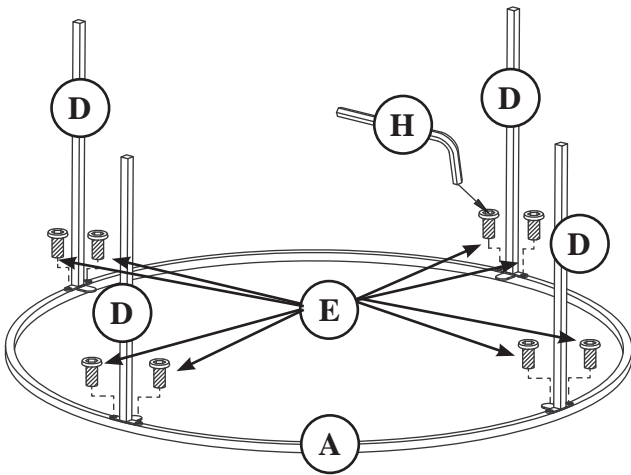

Fasten the TABLE LEGS (D) to the TOP RING (A). Use eight 10mm BOLTS (E). Do not tighten completely.

Carefully stand your unit upright. Fasten the BOTTOM RING (B) to the TABLE LEGS (D). Use four 20mm BOLTS (F).

2

**Caution**

Tempered safety glass is used. It is stronger than normal glass, and it will not break into long, sharp, knife-like shards. However, safety glass *can* break. When safety glass breaks, it instantly fractures into small, bead-like pieces. These small pieces may have sharp edges.

For your safety, follow these precautions when you assemble your product:

- Wear safety glasses or other eye protection.
- Do not try to drill into or cut safety glass. It will instantly break into small pieces.
- Do not force the glass into position.
- If the glass breaks, be careful when you pick up the pieces. They may have sharp edges.

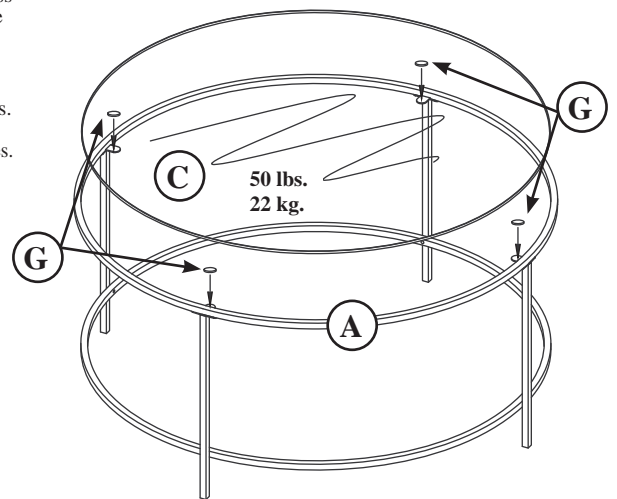

Stick the GLASS PADS (G) onto the TOP RING (A) as shown. Then, carefully set the GLASS TOP (C) onto the GLASS PADS.

This completes assembly.

## **⚠ WARNING**

Please use your furniture correctly and safely. Improper use can cause safety hazards, or damage to your furniture or household items. *Carefully read the following chart.*

Look out for:

What can happen:

How to avoid the problem:

- Improperly moving furniture.

- Furniture can break if improperly moved.
- Physical injury. Furniture can be very heavy.

- Do not push furniture, especially on a carpeted floor. Have a friend help you lift heavy items like a table and set it in place.