

Assembly Manual

Swivel Bar Stools

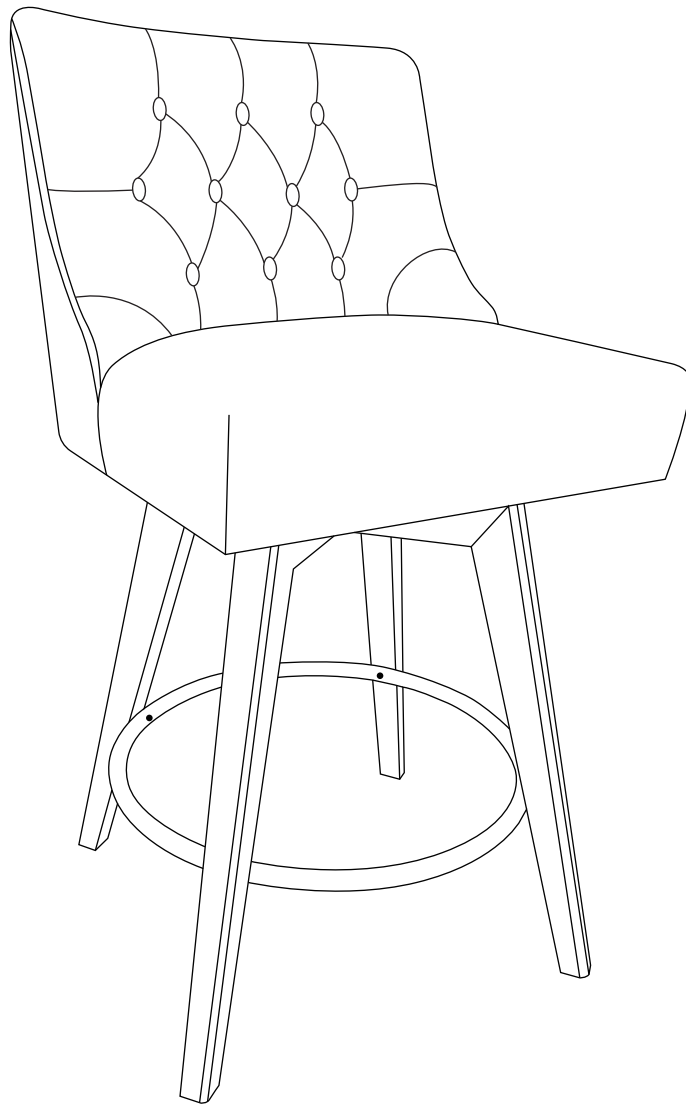

 **CAUTION**

THIS ASSEMBLY MANUAL CONTAINS IMPORTANT SAFETY INFORMATION.
PLEASE READ AND KEEP FOR FUTURE REFERENCE

PARTS

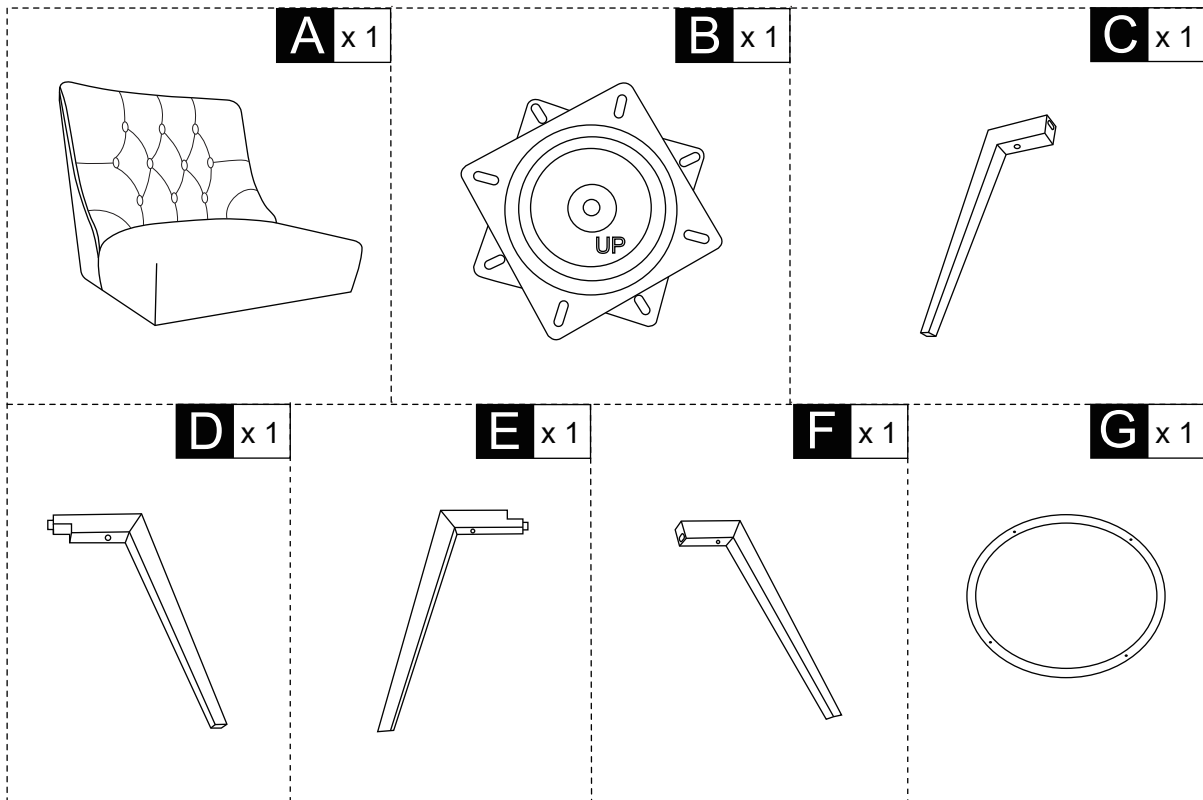

HARDWARE

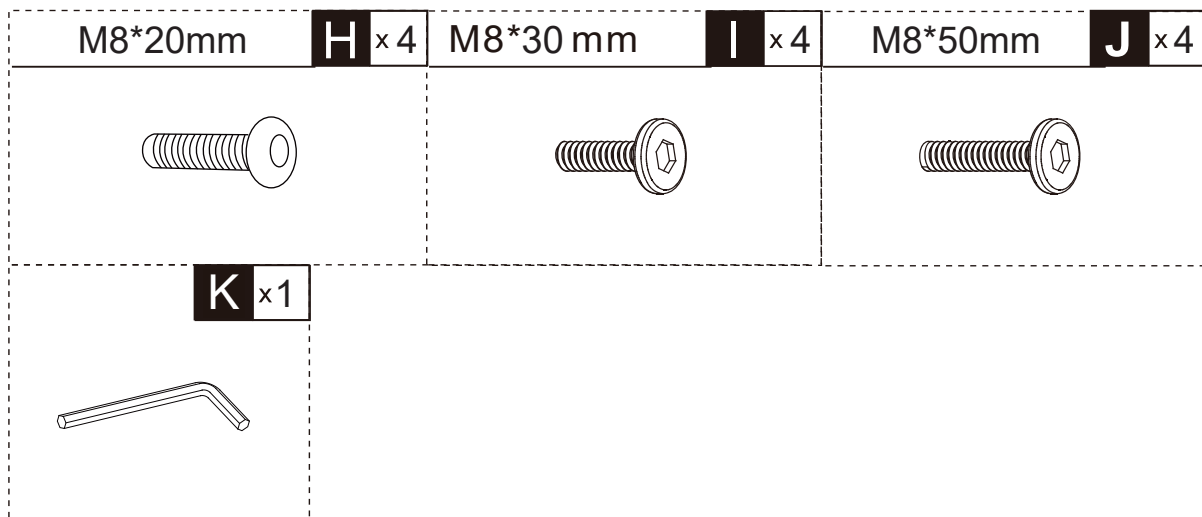

Before you begin:

1. Check if you have received all parts using the diagram on this page. Do not start the assembly process until all parts are present. If you have not received all parts or received wrong or damaged ones, please contact us and we will get back to you.
2. Do not discard any of the packaging until you are certain that you have all the necessary parts for the assembly.



1. Unpack and place seat (A), legs (C,D,E,F), foot rest (G) and swivel plate (B) on a clean surface.
Attach leg (C) to leg (D), leg (E) to (F).

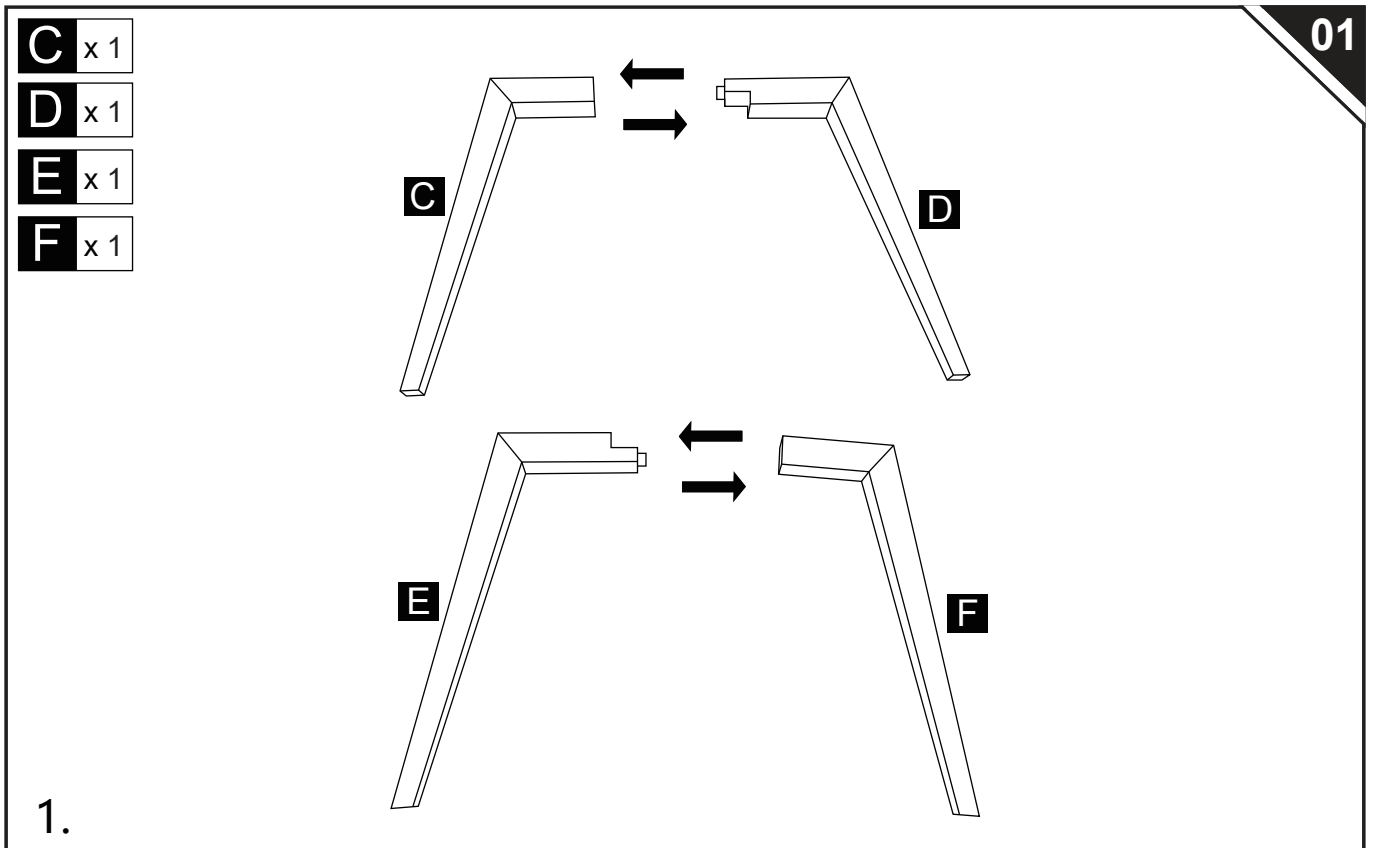

2. Loosely attach the bolts (I) one by one and keep them loose. **Do not fully tighten.** After all 4 bolts are attached, use allen wrench (K) to tighten.

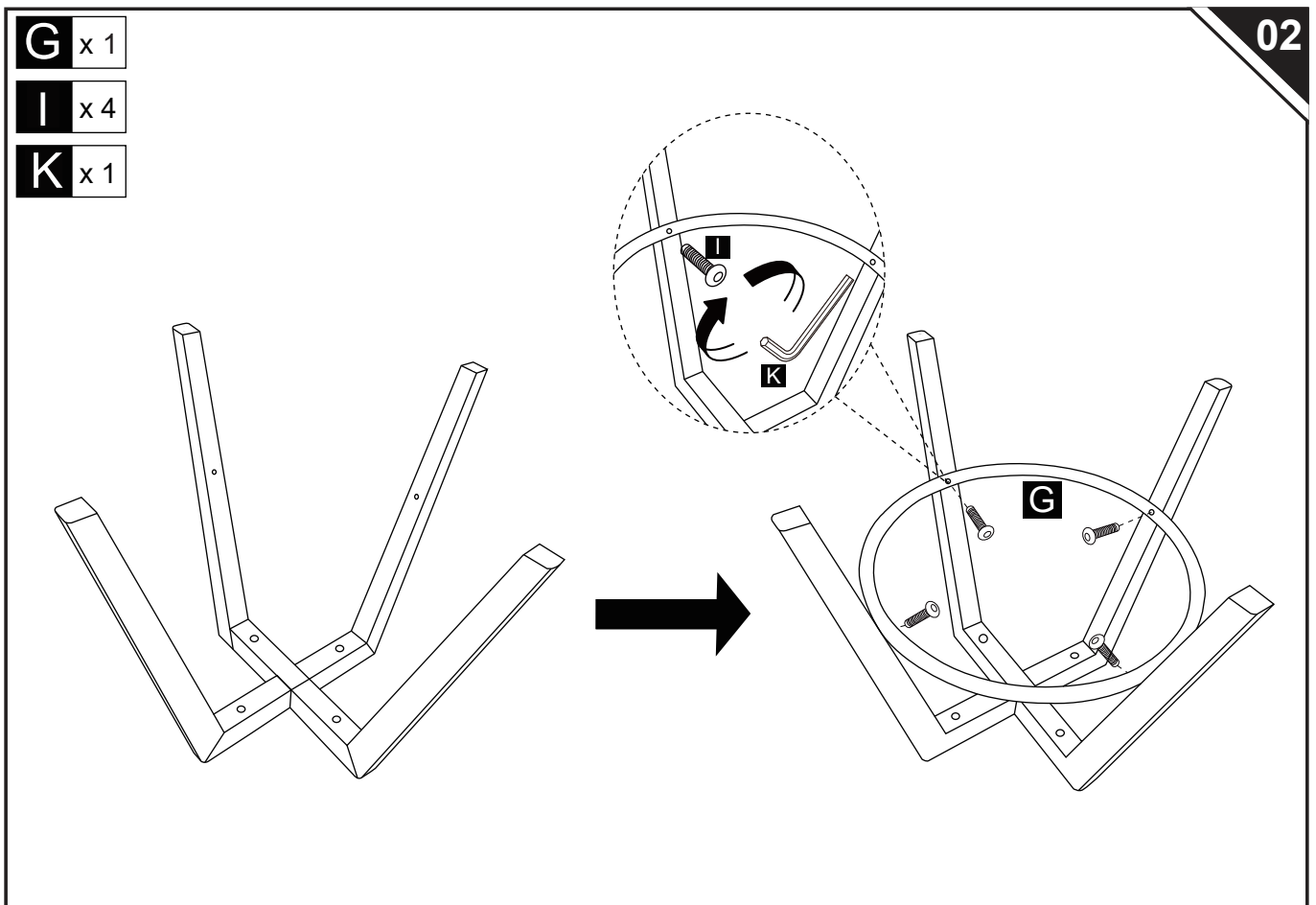

3. Attach swivel plate (B) to assembled legs in step 2, using bolts (J), allen wrench (K). **Do not fully tighten yet.**

B x 1

J x 4

K x 1

03

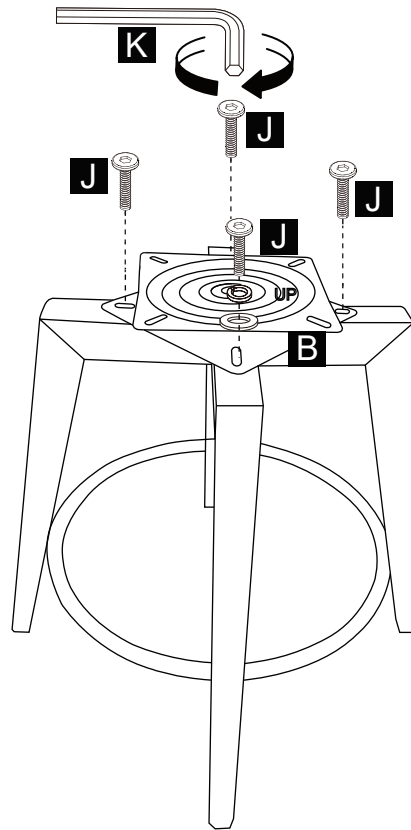

4. Put assembled legs in step 3 on a flat surface. Push legs up or down as necessary to level. Once level, **tighten all bolts.**

04

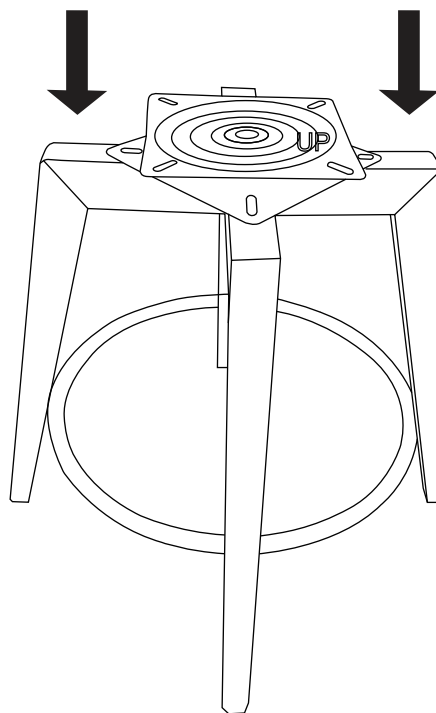

5. Attach assembled legs in step 3 to seat (A), using bolts (H), and allen wrench(K). **Note: Tighten all bolts.**

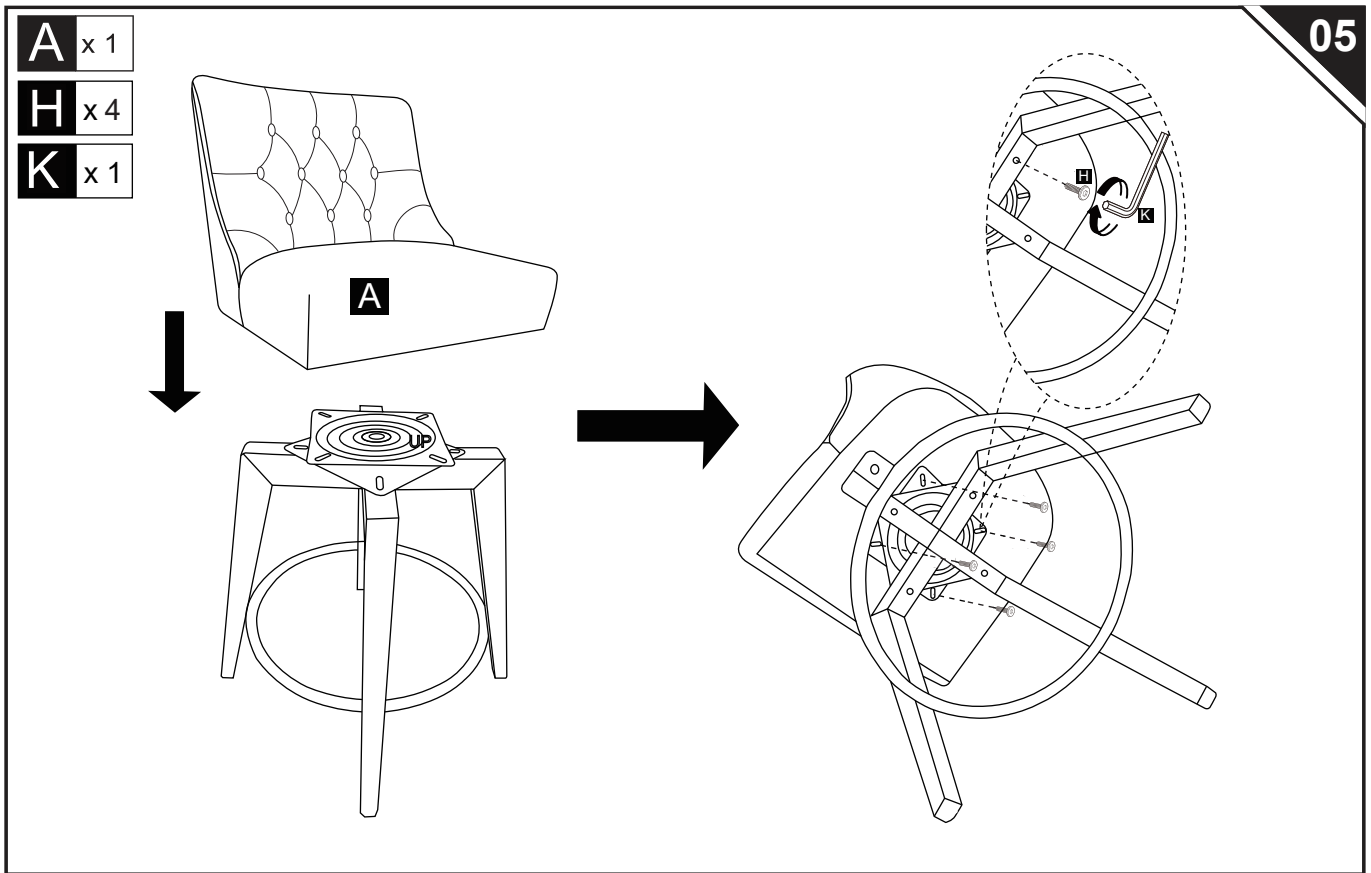

6. Turn assembled chair upright and place on a flat surface.
Note: each leg has an adjustable foot leveler to help level your chair.

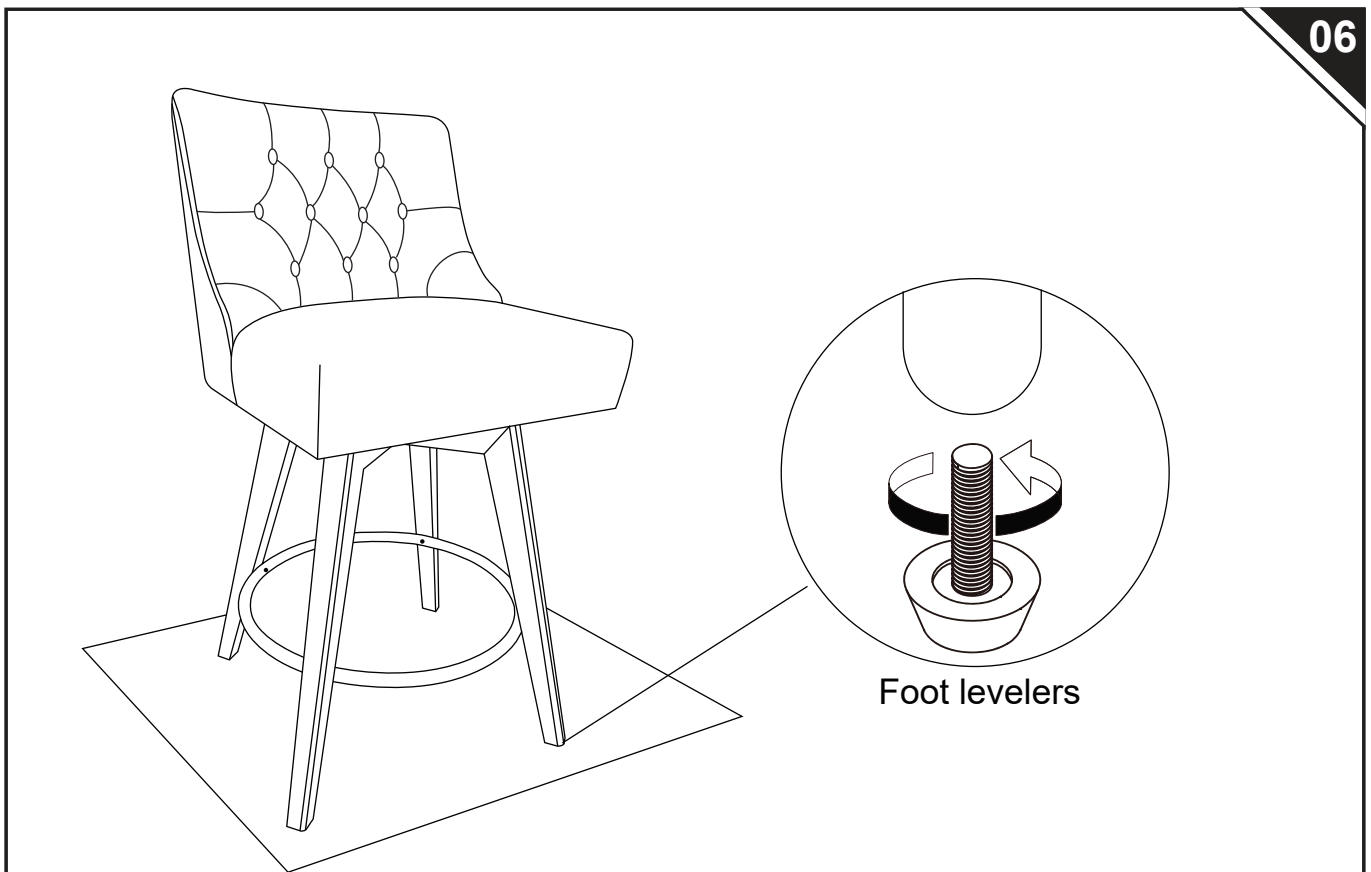

7.Assembly complete. Enjoy.

07

