

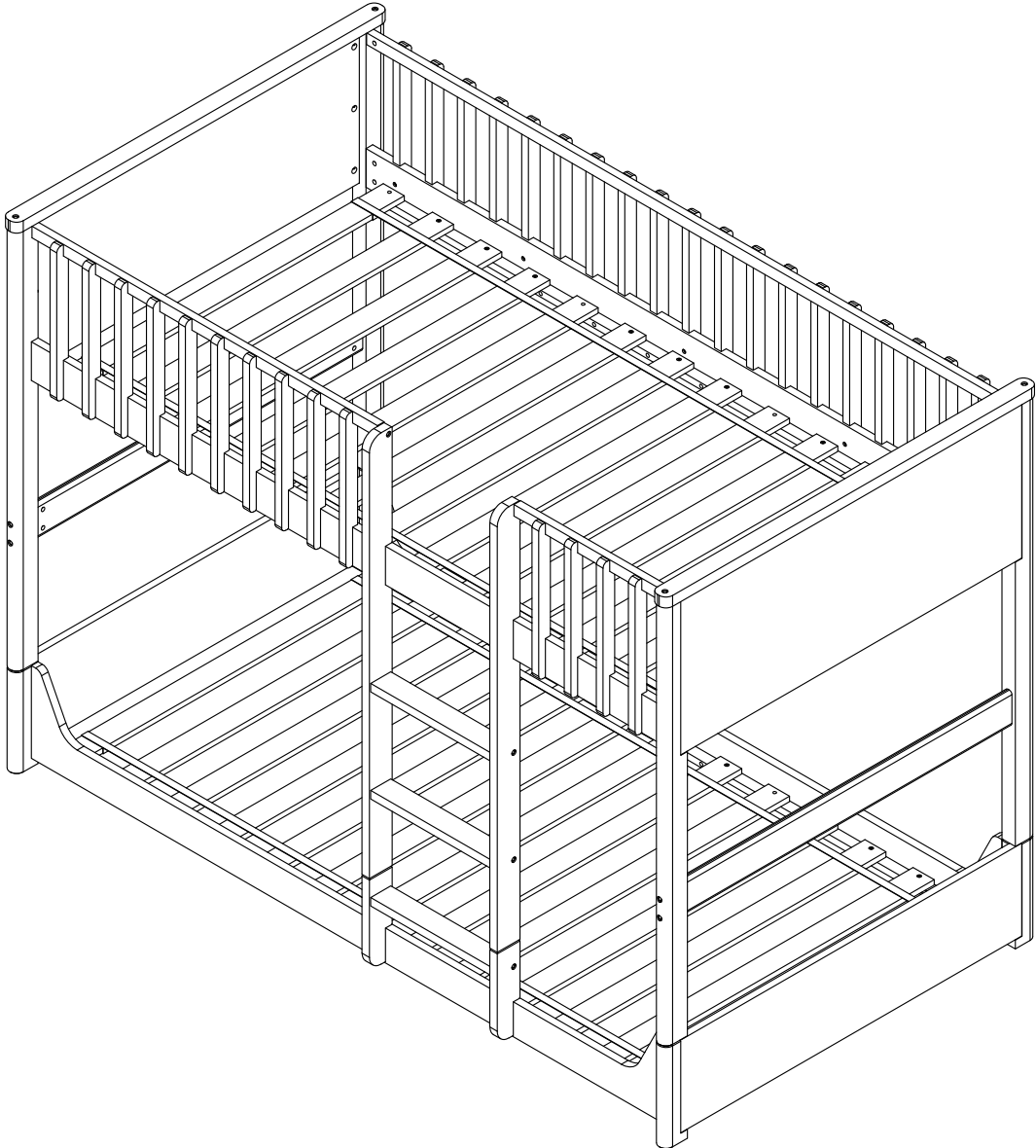





**ASSEMBLY INSTRUCTIONS / INSTRUCTIONS
D'ASSEMBLAGE / INSTRUCTIVO DEARMADO**



NOTES ON ASSEMBLY / NOTES POUR L'ASSEMBLAGE / NOTAS SOBRE EL ENSAMBLE

- To ensure ease of assembly read all instructions before assembly and follow step by step illustrations.
- Keep instructions for future use.
- Adult assembly required.  2 person required. 
- Due to the present of small parts during assembly, keep out of reach of children until assembly is complete.

- Pour assurer l'assemblage facile veuillez lire toutes les instructions avant l'assemblage et veuillez suivre les illustrations pour chaque etapes.
- Veuillez garder ces instructions pour l'usage ulterieur.
- Assemblage requis pas un adulte.  2 personnes requises. 
- Due a la presence de petite pieces durant l'assemblage, veuillez garder hors de porter des enfants jusqu'a ce que l'assemblage soit completer.

- Para garantizar la facilidad de ensamble lea las instrucciones antes de iniciar y siga paso a paso las ilustraciones.
- Guarde las instrucciones para futuras referencias.
- El ensamble requiere de un adulto.  2 personas requeridas. 
- Debido a que hay piezas pequeñas, mantenga fuera del alcance a los niños durante el ensamble, hasta que haya terminado.

MAINTENANCE TIPS / CONSEILS D'ENTRETIEN / CONSEJOS DE MANUTENIMIENTO

- Never let liquids or damp cloths sit on this furniture.
- Never use chemical cleaning products. They can damage the finish. For cleaning, use only a slightly damp cloth and wipe dry.
- To avoid dulling of the finish, do not place furniture in direct sunlight.
- Do not put plastic or rubber rings under appliances. Use cloth of felt protectors.
- To clean, use a soft or slightly damp cloth, then wipe with a clean, dry cloth.

- Ne jamais laisser de liquide ou linge humide sur le meuble.
- Ne jamais utiliser de nettoyeurs à base de produits chimiques, cela va endommager le fini. Utiliser seulement un linge légèrement humide.
- Ne pas placer le meuble directement au soleil pour prévenir le ternissement.
- Évitez de déposer des appareils avec des rondelles de plastique ou de caoutchouc. Utilisez un protecteur en tissu ou en feutre.
- Pour nettoyer, utilisez un linge doux ou légèrement humecté. Essuyez par la suite avec un linge propre et sec.

- Nunca deje un líquido o un trapo húmedo sobre el mueble.
- Nunca utilice limpiadores a base de químicos, estos dañaran le acabado. Use sólo un paño húmedo.
- No exponga el mueble directamente al sol para prevenir empañamiento.
- Evite apoyar aparatos con redondeles de plástico o de goma. Utilizar un protector de tela o de fieltro.
- Para limpiar, utilice un trapo suave o ligeramente humedecido. Seque luego con un trapo limpio y seco.

⚠ WARNING ⚠

AVERTISSEMENT / ADVERTENCIA

Please use your furniture correctly and safely. Improper use can cause safety hazards, or damage to your furniture or household items. To help prevent serious or fatal injuries from entrapment or falls:

- Follow the information on the warnings appearing on the upper bunk end structure and on the carton. Do not remove warning label from bed
- Always use the recommended size mattress or mattress support, or both, to help prevent the likelihood of entrapment or falls.
- Use only mattress which is 74-75 inches long and 37½-38½ inches wide on upper and lower bunk bed. Ensure thickness of mattress and foundation combined does not exceed 7 inches and that mattress surface is at least 5 inches (127mm) below the upper edge of guardrails.
- Do not allow children under 6 years of age to use the upper bunk.
- Prohibit more than one person on the upper bunk at all times.
- Periodically check and ensure that the guardrail, ladder, and other components are in their proper position, free from damage, and that all connectors are tight.
- Do not allow horseplay on or under the bed and prohibit jumping on the bed.
- Always use the ladder for entering and leaving the upper bunk.
- Do not use substitute parts. Contact the manufacturer or dealer for replacement parts
- Use of a night light may provide added safety precaution for a child using the upper bunk.
- Always use guardrails on both long sides of the upper bunk. If the bunk bed will be placed next to the wall, the guardrail that runs the full length of the bed should be placed against the wall to prevent entrapment between the bed and wall.
- The use of water or sleep flotation mattresses is prohibited.
- STRANGULATION HAZARD - Never attach or hang items to any part of the bunk bed that are not designed for use with the bed; for example: but not limited to - hooks, belts, and jump ropes.

Replacement Parts:

Replacement parts, including additional guardrails may be obtained from any dealer.

Prière d'utiliser le mobilier à bon escient et avec prudence. Une mauvaise utilisation peut être à l'origine de risques d'accident ou peut endommager le mobilier et les articles ménagers.

Para ayudar a prevenir lesiones graves o fatales por atrapamiento o caídas:

- Siga la información de las advertencias, que aparece en la estructura del extremo de la litera superior y en el cartón. No quite la etiqueta de advertencia de la cama
- Utilice siempre el tamaño recomendado del colchón o soporte del colchón, o ambos, para ayudar a prevenir probabilidad de atrapamiento o caídas
- Use solo colchones de 74-75 pulgadas de largo y 37½-38½ pulgadas de ancho en la litera superior e inferior. Garantizar el grosor del colchón y la base combinada no excede las 7 pulgadas que la superficie del colchón es de al menos 5 pulgadas (127 mm) debajo del borde superior de las barandillas.
- No permita que niños menores de 6 años usen la litera superior.
- Prohibir a más de una persona en la litera superior en todo momento.
- Verifique periódicamente y asegúrese de que la barandilla, la escalera y otros componentes están en su posición correcta, libre de daños, y que todos los conectores están apretados.
- No permita juegos bruscos sobre o debajo de la cama y prohibir saltar en la cama.
- Siempre use la escalera para entrar y salir de la litera superior.
- No use piezas de repuesto. Contacte al fabricante o distribuidor de repuestos.
- El uso de una luz nocturna puede proporcionar mayor seguridad. Precaución para un niño que usa la litera superior.
- Utilice siempre barandillas en ambos lados largos de la litera superior. Si la litera se colocará a continuación a la pared, la barandilla que recorre toda la longitud de la cama debe colocarse contra la pared para evitar el atrapamiento entre la cama y la pared.
- El uso de agua o colchones de flotación para dormir está prohibido
- PELIGRO DE ESTRANGULACIÓN: nunca coloque ni cuelgue artículos en ninguna parte de la litera que no estén diseñados para usarse con la cama; por ejemplo: pero no limitado a ganchos, cinturones y cuerdas para saltar.

Piezas de Repuesto:

Piezas de repuesto, incluyendo barandales adicionales pueden obtenerse de cualquier distribuidor

Por favor use el mobiliario correctamente y seguramente. El mal uso puede causar riesgos de seguridad o daño a las unidades o artículos domésticos.

Pour aider à prévenir les blessures graves ou fatales causées par le piégeage ou les chutes:

- Suivez les informations sur les avertissements apparaissant sur la structure de la couchette supérieure et sur le carton. Ne retirez pas l'étiquette d'avertissement du lit.
- Toujours utiliser le matelas de taille recommandée ou le support de matelas, ou les deux, pour aider à prévenir la probabilité de piégeage ou de chutes.
- Utilisez seulement un matelas de 74-75 pouces de long et 37½-38½ de large sur la couchette supérieure et inférieure. Assurez-vous que l'épaisseur du matelas et de la base combinés ne dépasse pas 7 pouces et que la surface du matelas soit au moins de 5 pouces (127 mm) au-dessous du bord supérieur des garde-corps.
- Ne laissez pas les enfants de moins de 6 ans utiliser la couchette supérieure.
- Interdire plus d'une personne sur la couchette supérieure en tout temps.
- Vérifier périodiquement que le garde-corps, l'échelle et les autres composants sont dans leur position correcte, exempts de dommages et que tous les connecteurs sont serrés.
- Ne laissez pas bavarder sur ou sous le lit interdisez de sauter sur le lit.
- Toujours utiliser l'échelle pour entrer et sortir de la couchette supérieure.
- N'utilisez pas de pièces de rechange. Contacter le fabricant ou le revendeur pour les pièces de rechange.
- L'utilisation d'une lampe de nuit peut fournir une précaution de sécurité supplémentaire pour un enfant utilisant la couchette supérieure.
- Utilisez toujours des garde-corps sur les deux côtés longs de la couchette supérieure. Si le lit superposé sera placé à côté du mur, le garde-corps qui s'étend sur toute la longueur du lit doit être placé contre le mur pour empêcher le piégeage entre le lit et le mur.
- L'utilisation d'eau ou de matelas de flottaison est interdite.
- DANGER STRANGULATION - Ne jamais attacher ou accrocher des articles à une partie du lit superposé qui ne sont pas conçus pour être utilisés avec le lit; Par exemple: mais sans y limiter - des crochets, des ceintures et des cordes à sauter.

Pièces de remplacement:

Les pièces de remplacement, incluant les rails de protection additionnels, peuvent être obtenus chez n'importe quel détaillant

PARTS IDENTIFICATION

IDENTIFICATION DES PIÈCES

IDENTIFICACIÓN DE LAS PARTES

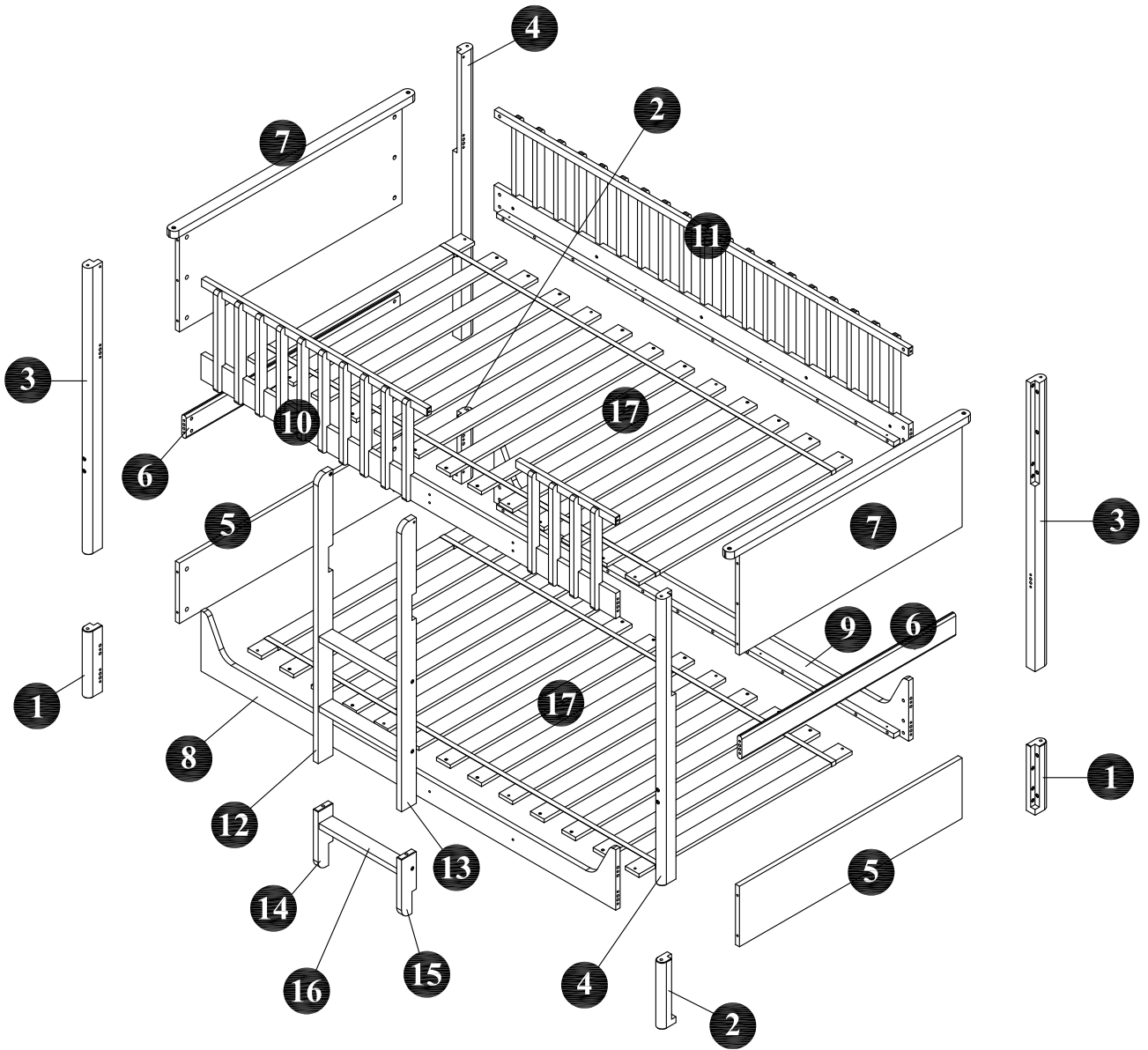









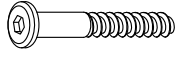
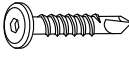

Part	Name of Part List	Qty
1	Lower Leg (Left Front & Right Rear)	2
2	Lower Leg (Right Front & Left Rear)	2
3	Upper Leg (Left Front & Right Rear)	2
4	Upper Leg (Right Front & Left Rear)	2
5	Lower Headboard/Footboard Panel	2
6	Support Rail	2
7	Upper Headboard/Footboard Panel	2
8	Lower Front Side Rail	1
9	Lower Rear Side Rail	1

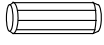
Part	Name of Part List	Qty
10	Front Guard Rail	1
11	Rear Guard Rail	1
12	Upper Left Ladder Rail	1
13	Upper Right Ladder Rail	1
14	Lower Left Ladder Rail	1
15	Lower Right Ladder Rail	1
16	Ladder Stretcher	3
17	Slat	2

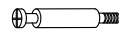
HARDWARE

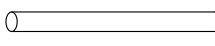
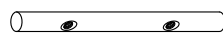
QUINCAILLERIE / HERRAJE

A	JCBC Bolt M6 x 100mm	B	JCBC Bolt M6 x 60mm	C	JCBC Bolt M6 x 35mm
					
	8 Units		36 Units		10 Units
D	JCBC-W M6 x 28mm	E	CSK Screw M4 x 28mm	F	Wood Dowel M10 x 30mm
					
	16 Units		36 Units		38 Units
G	M6 x 13mm Barrel Nut	H	Minifix Bolt	I	Minifix Cam
					
	40 Units		20 Units		20 Units
J	METAL HOLLOW PIN	K	METAL PIN WITH HOLE	L	M4 Allen Key
					
	4 Units		2 Units		1 Unit

- Hardware quantity may supplied more than it required. Please keep spares and tools for future use.
- La cantidad de hardware puede suministrarse más de lo requerido. Guarde los repuestos y las herramientas para uso futuro.
- La quantité de matériel peut fournir plus que nécessaire. Veuillez conserver les pièces de rechange et les outils pour une utilisation future.

TOOLS NOT INCLUDED

OUTILS PAS INCLUS / HERRAMIENTAS NO INCLUIDAS

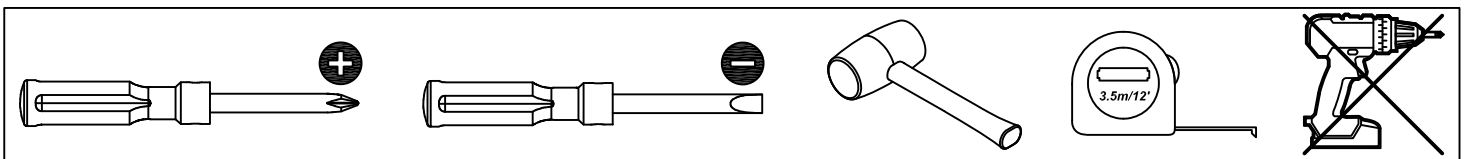

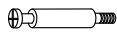

STEP 1

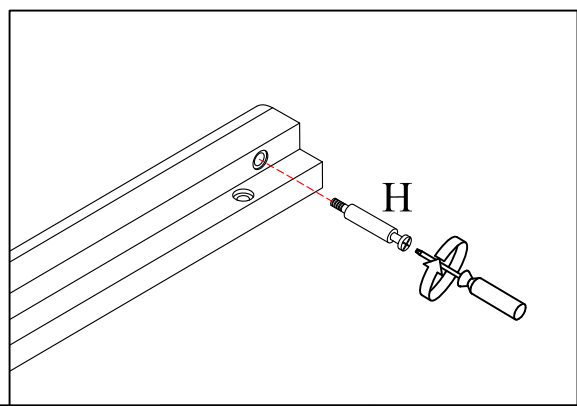
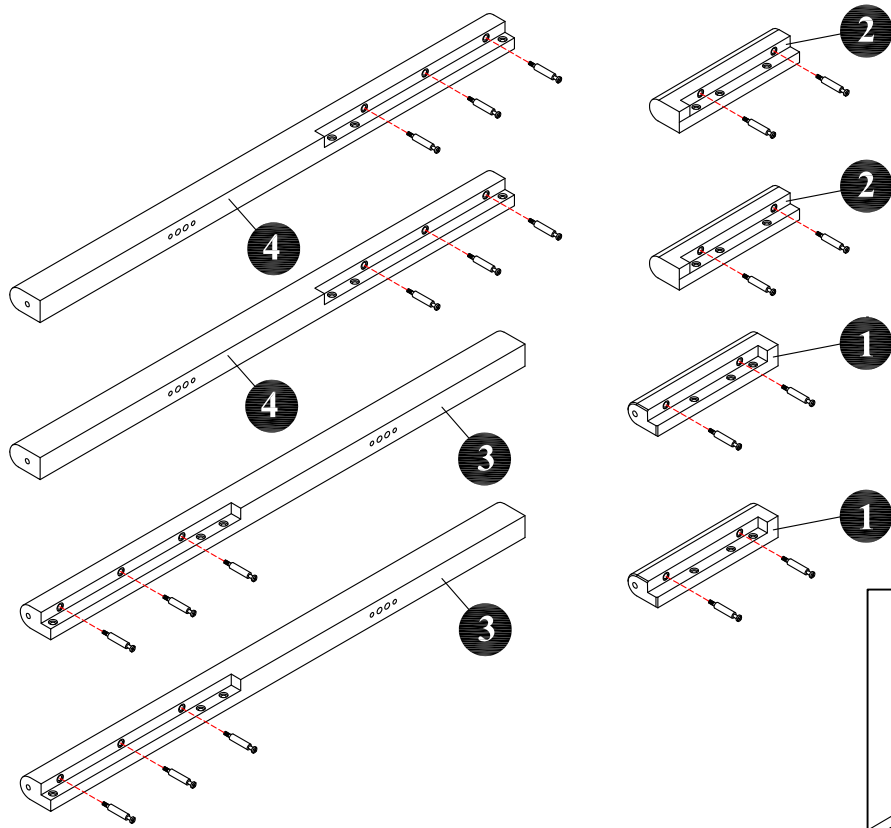
H x 20





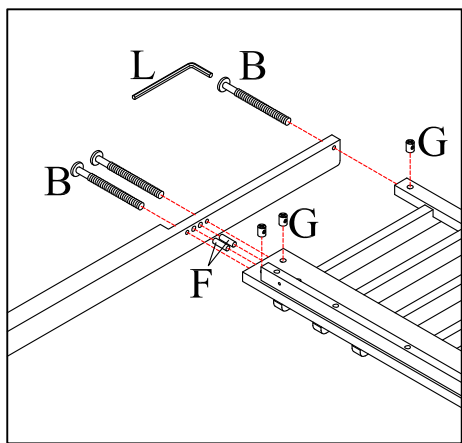
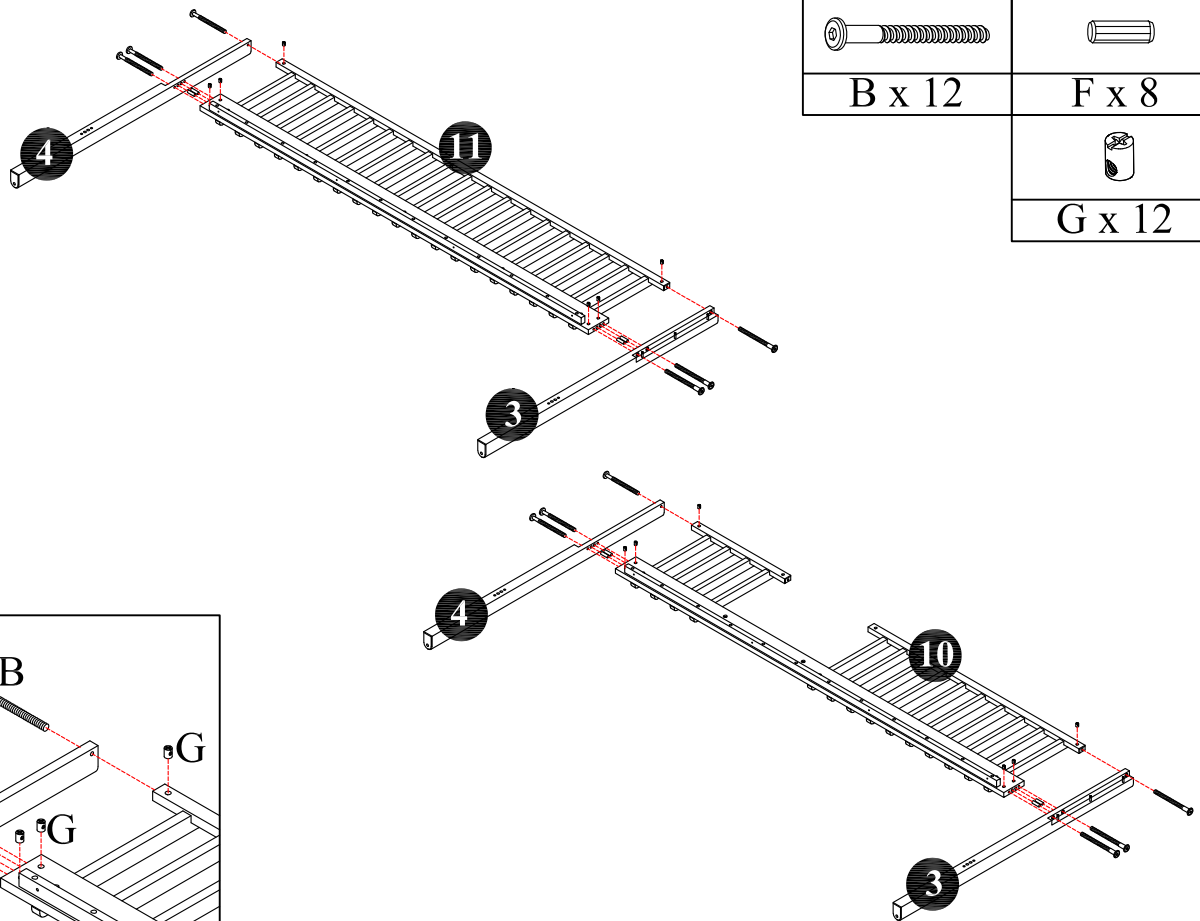

STEP 2

	
B x 12	F x 8
	
	G x 12



STEP 3

	
A x 8	F x 8
	
I x 12	G x 8

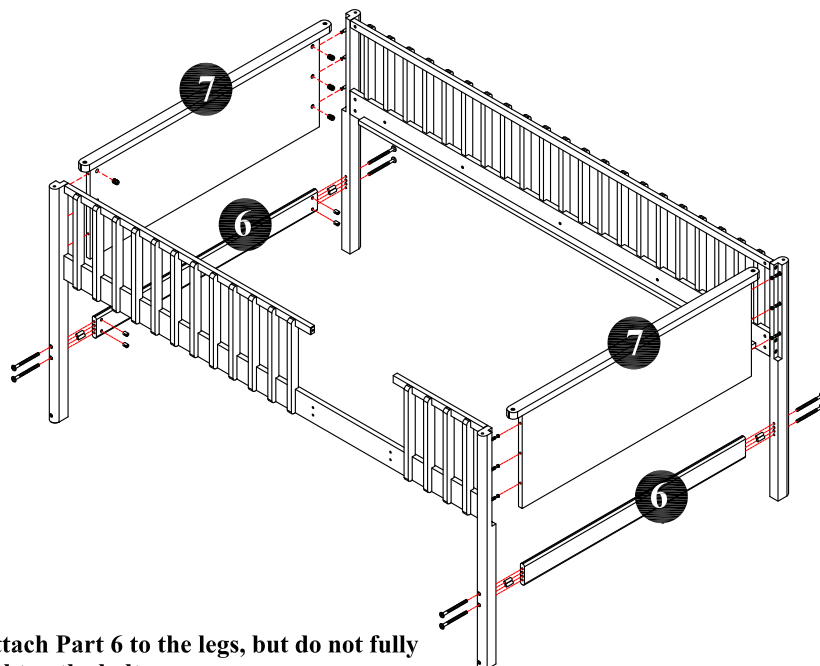
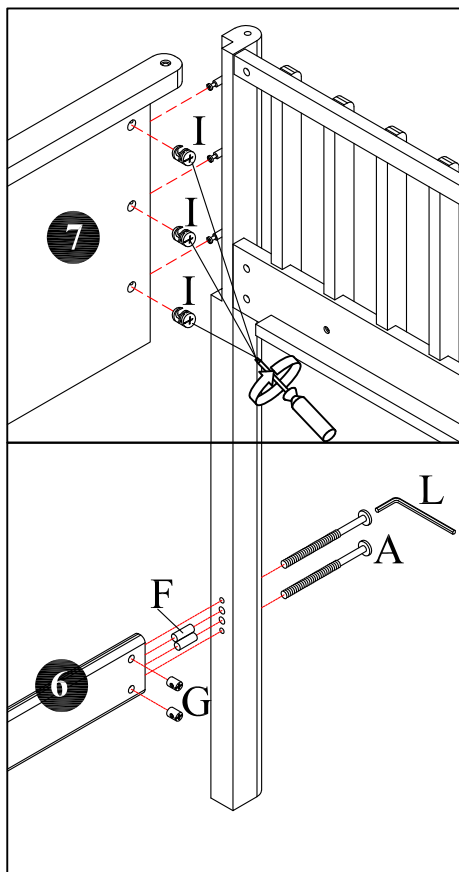

Attach Part 6 to the legs, but do not fully tighten the bolts.
Then attach Part 7 to the legs.
After that, fully tighten the bolts on Part 6.

STEP 4

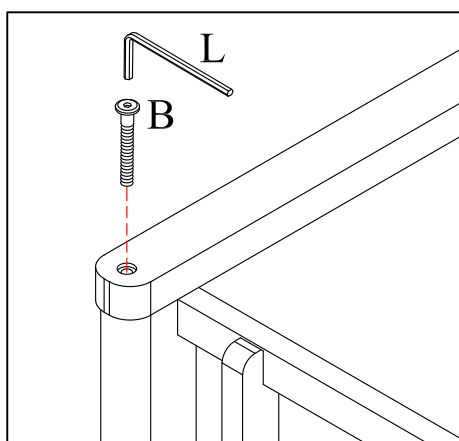
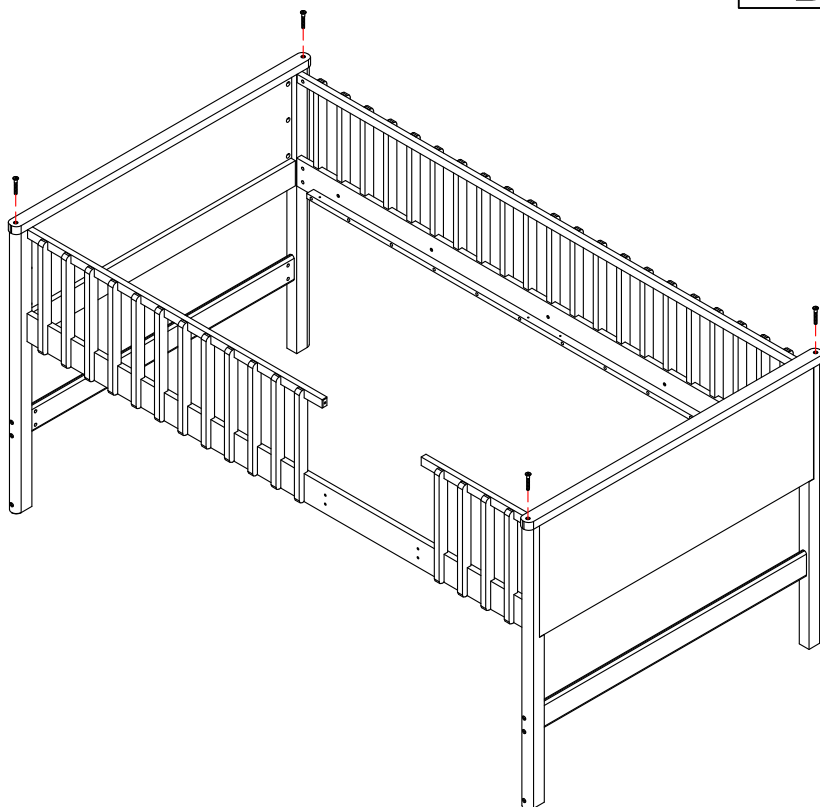

B x 4



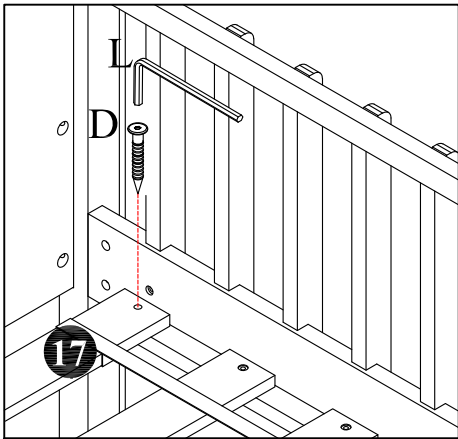
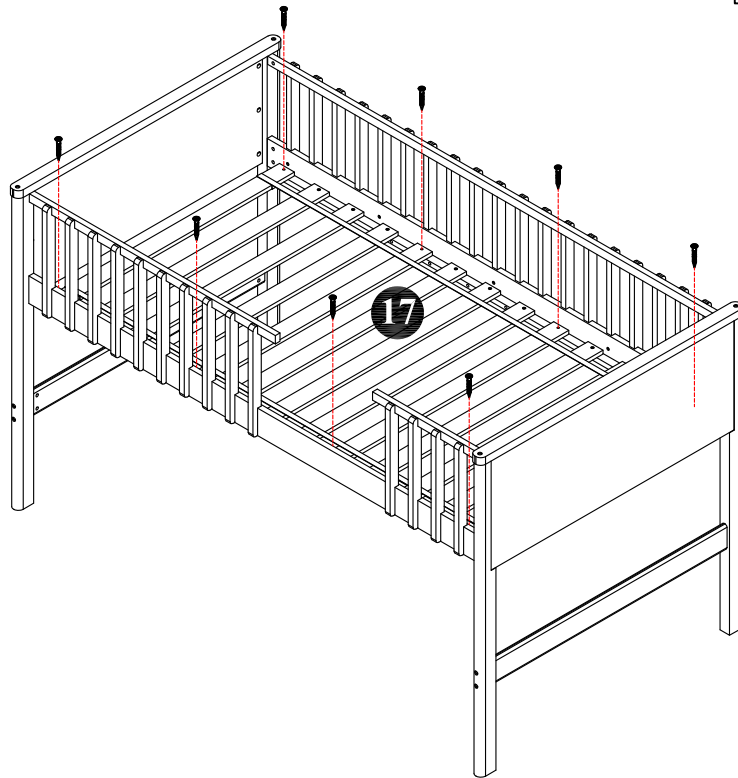
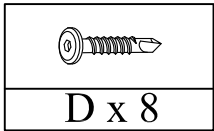

STEP 5

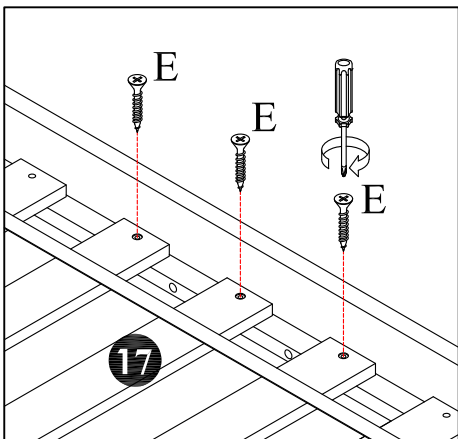
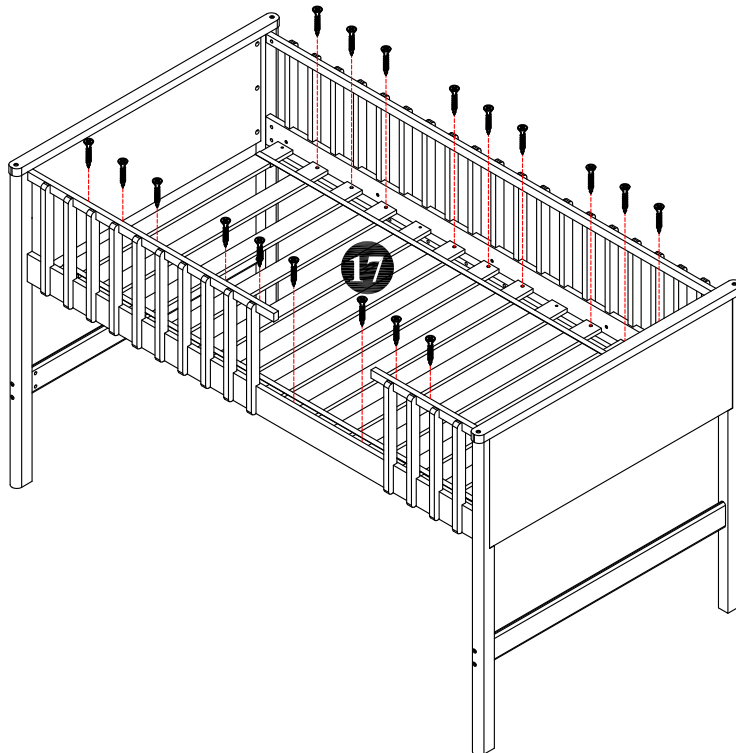
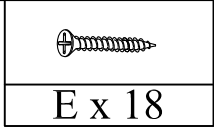

STEP 6



STEP 7

	
B x 12	F x 16
	
	G x 12

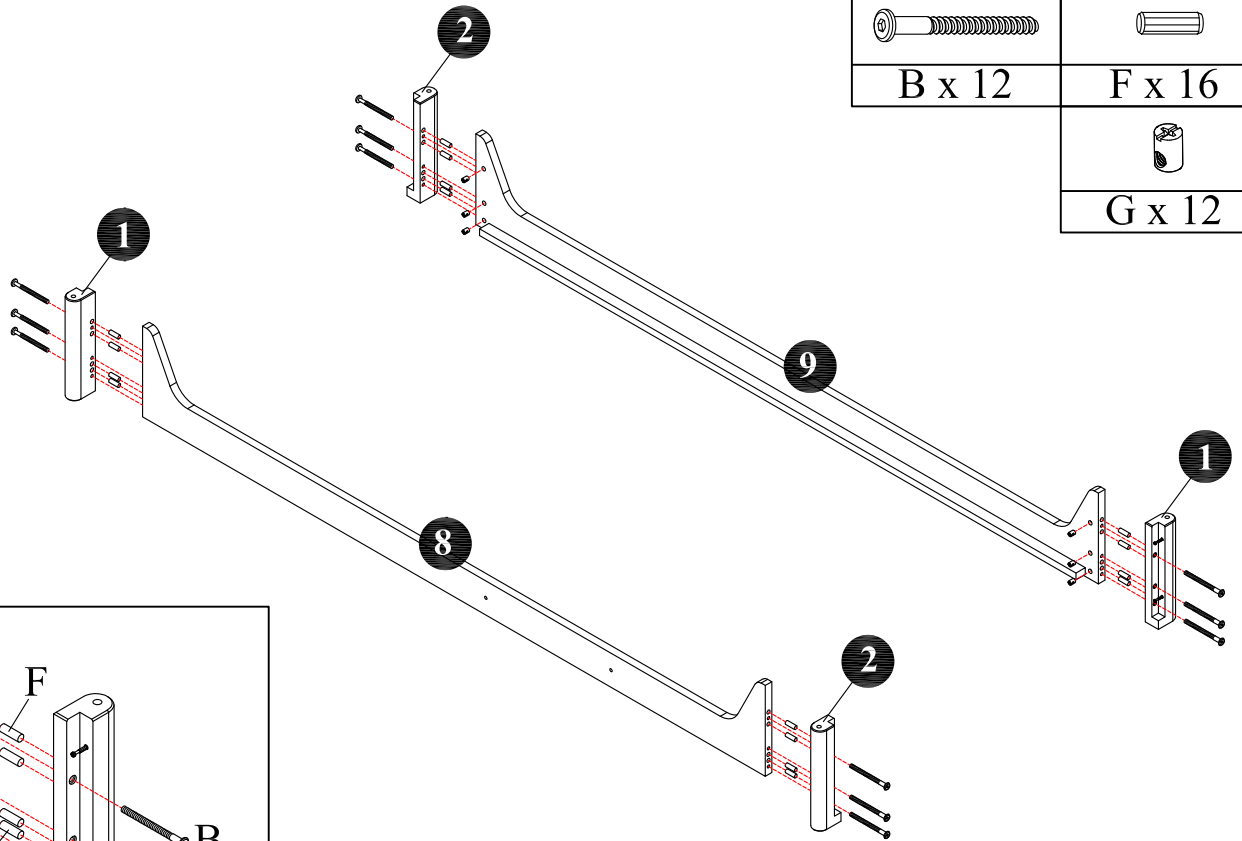
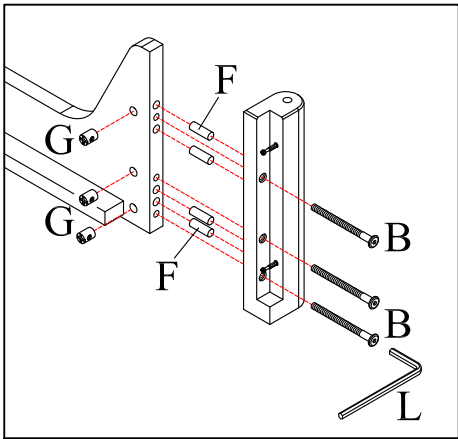

STEP 8

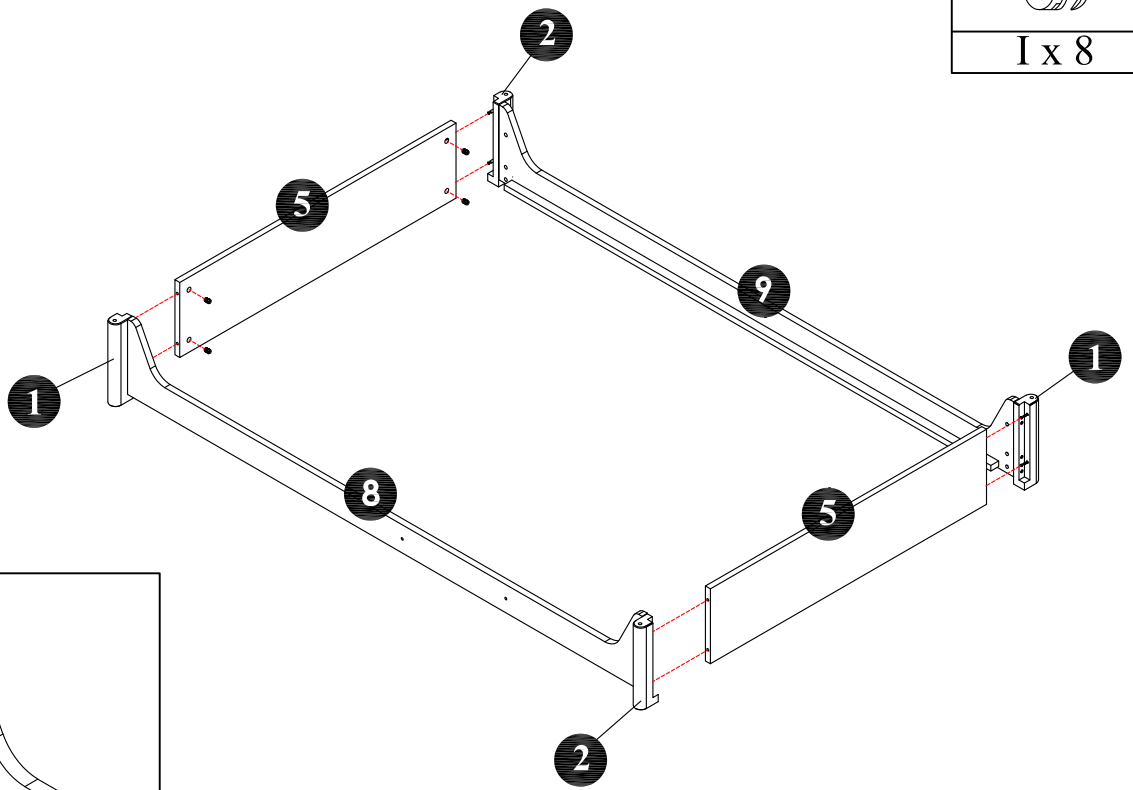
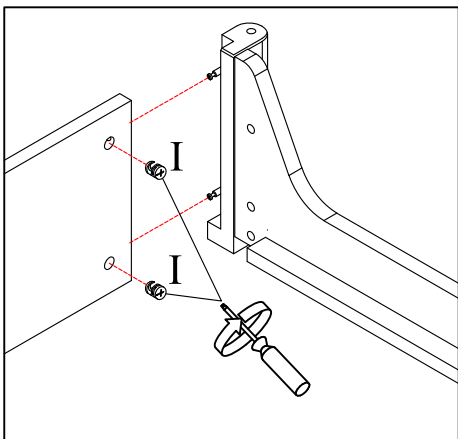

I x 8

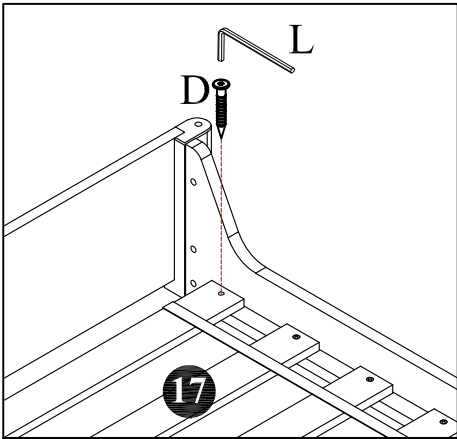
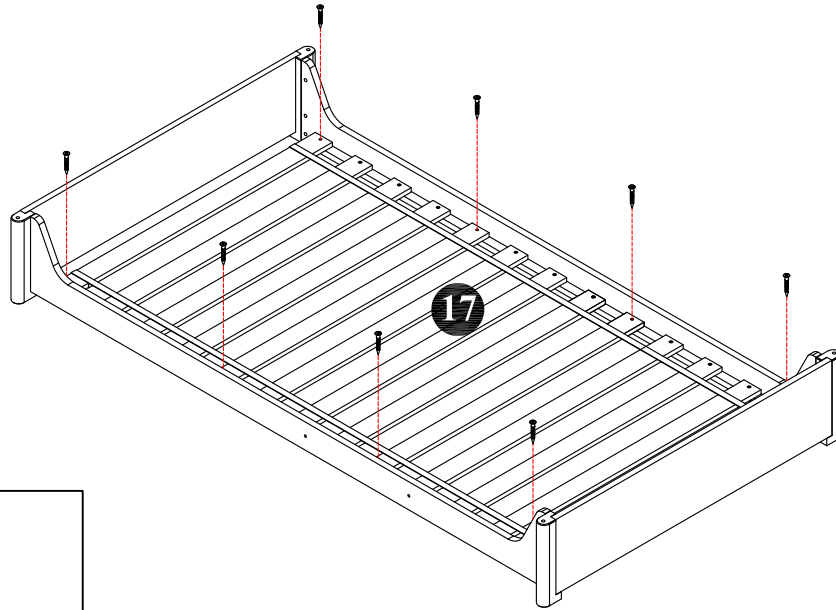
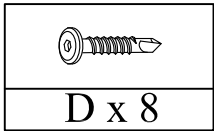

STEP 9

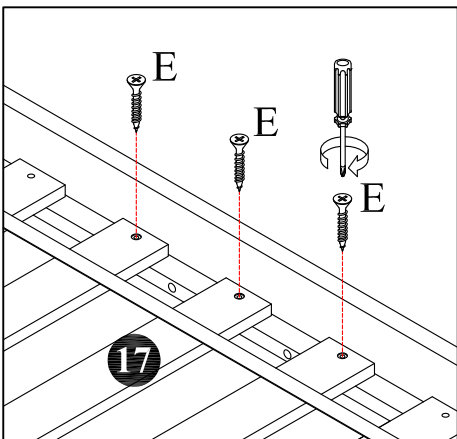
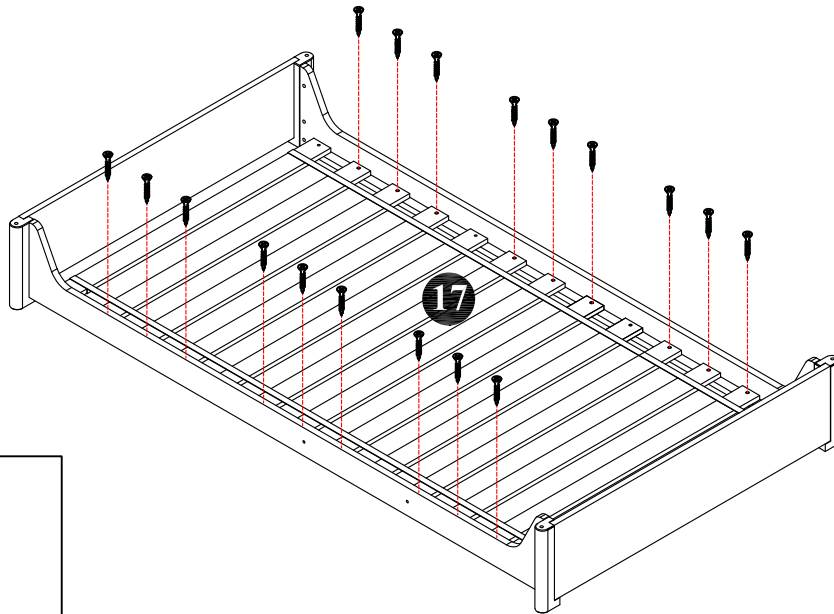
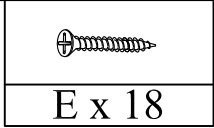

STEP 10



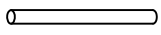

STEP 11

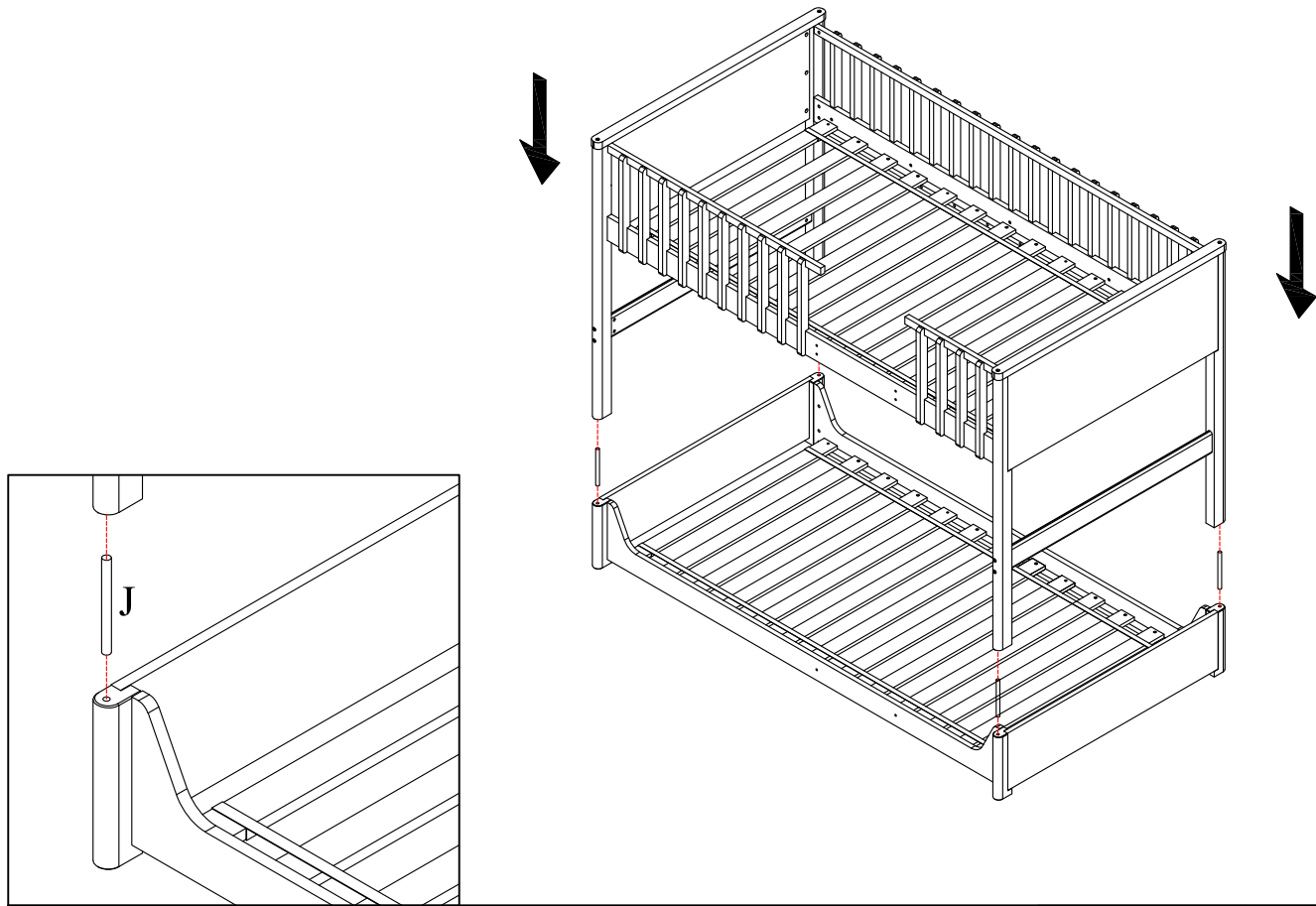
J x 4



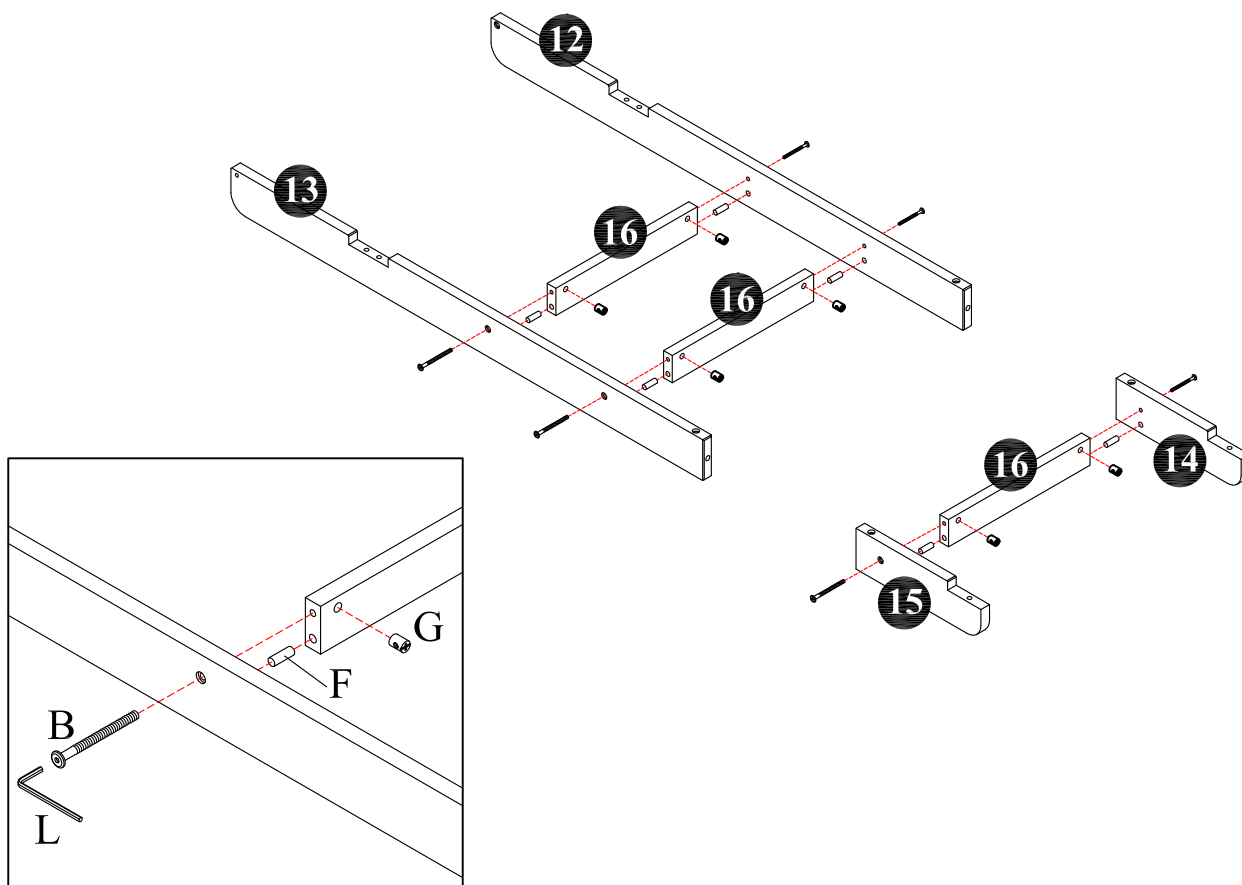

STEP 12

	
B x 6	F x 6
	
	G x 6



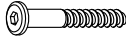

STEP 13

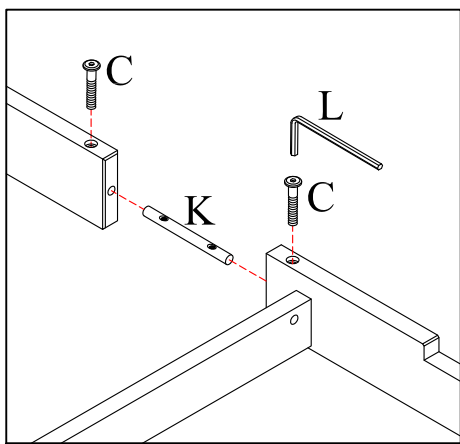
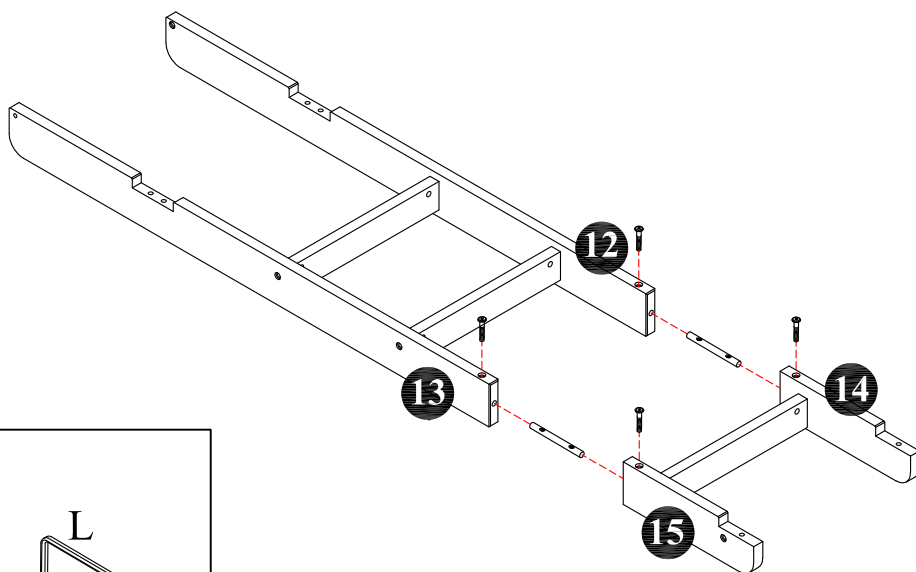
	
C x 4	K x 2

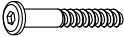

STEP 14

	
B x 2	C x 6
	
	G x 2

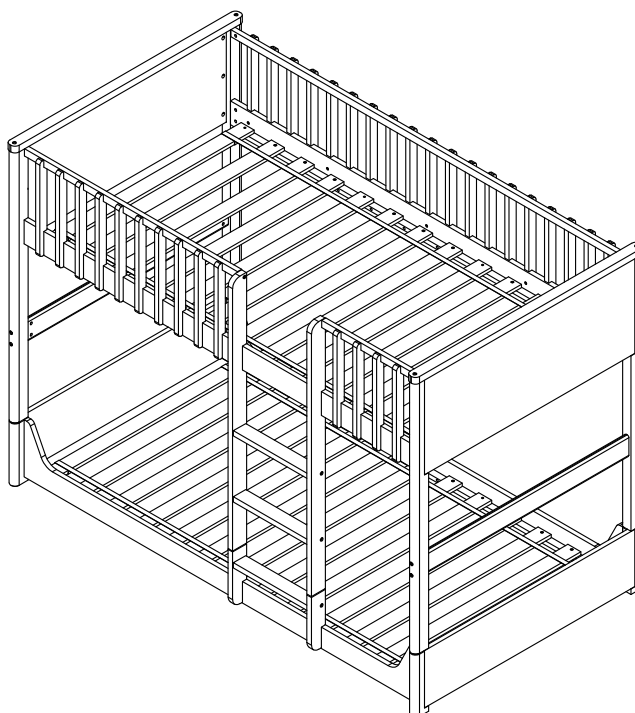
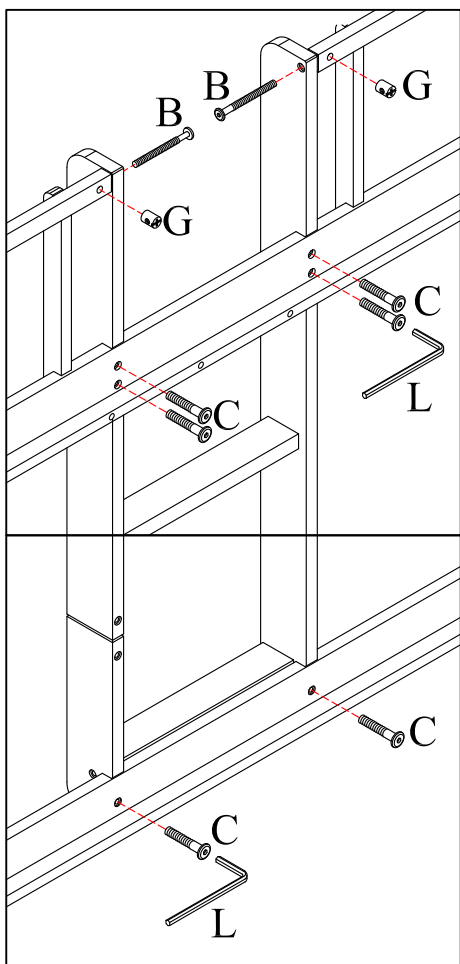

STEP 15 COMPLETE ASSEMBLY FOR BUNK BED

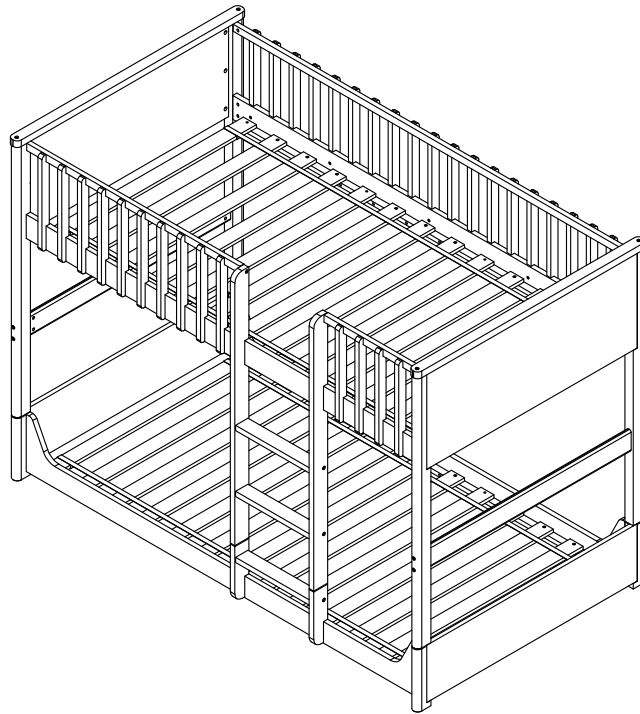

STEP 16 INSTRUCTION TO CHANGE BUNK BED INTO KIDS LOFT

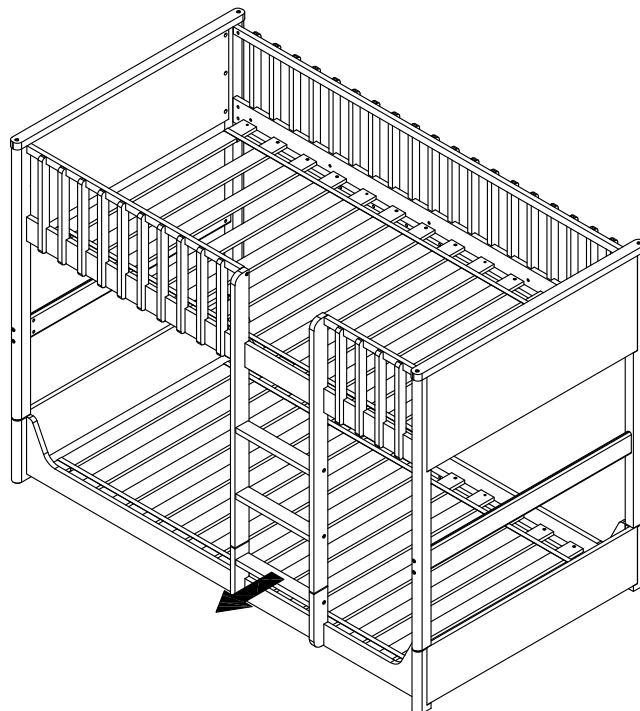
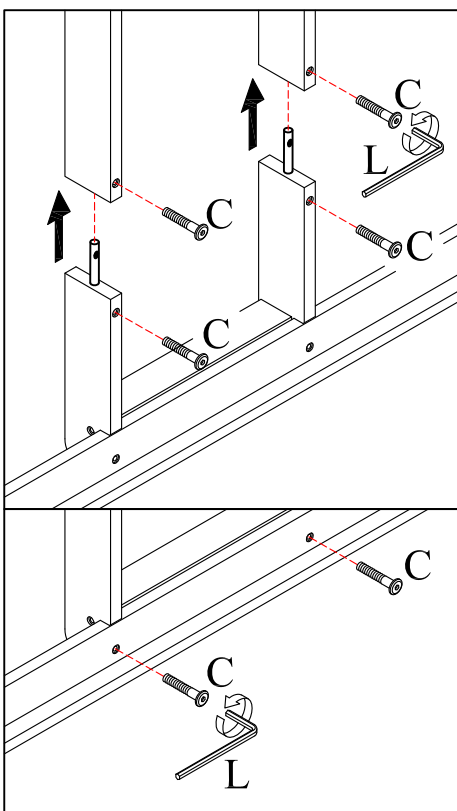

STEP 17

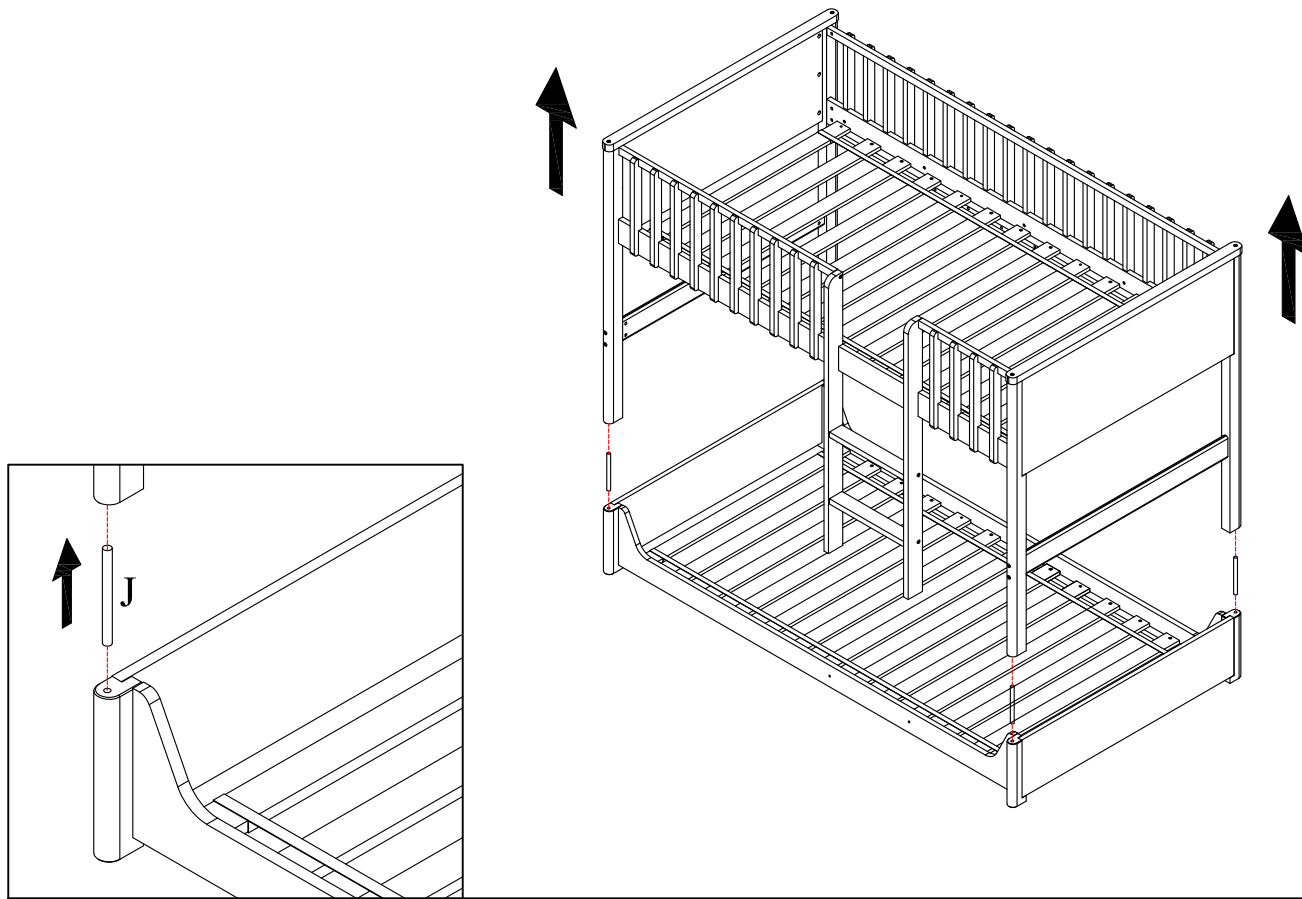

STEP 18 COMPLETE ASSEMBLY FOR KIDS LOFT

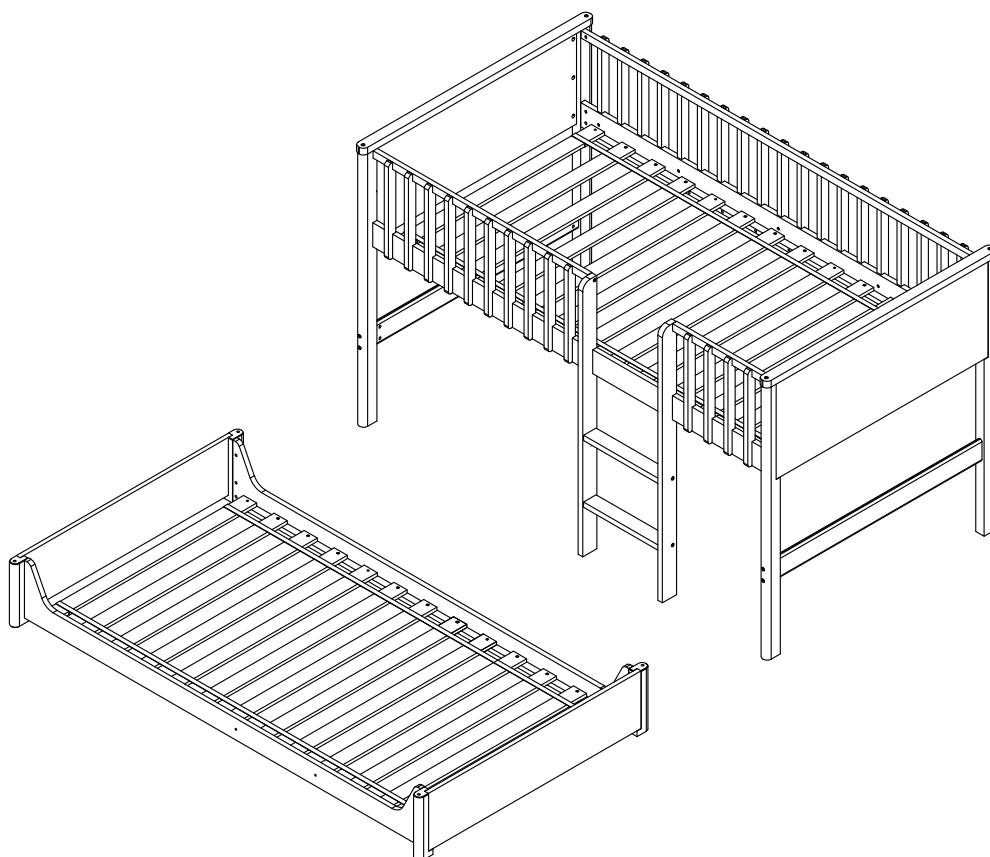

MAXIMUM LOADS CHARGES MAXIMALES / CARGA MAXIMA

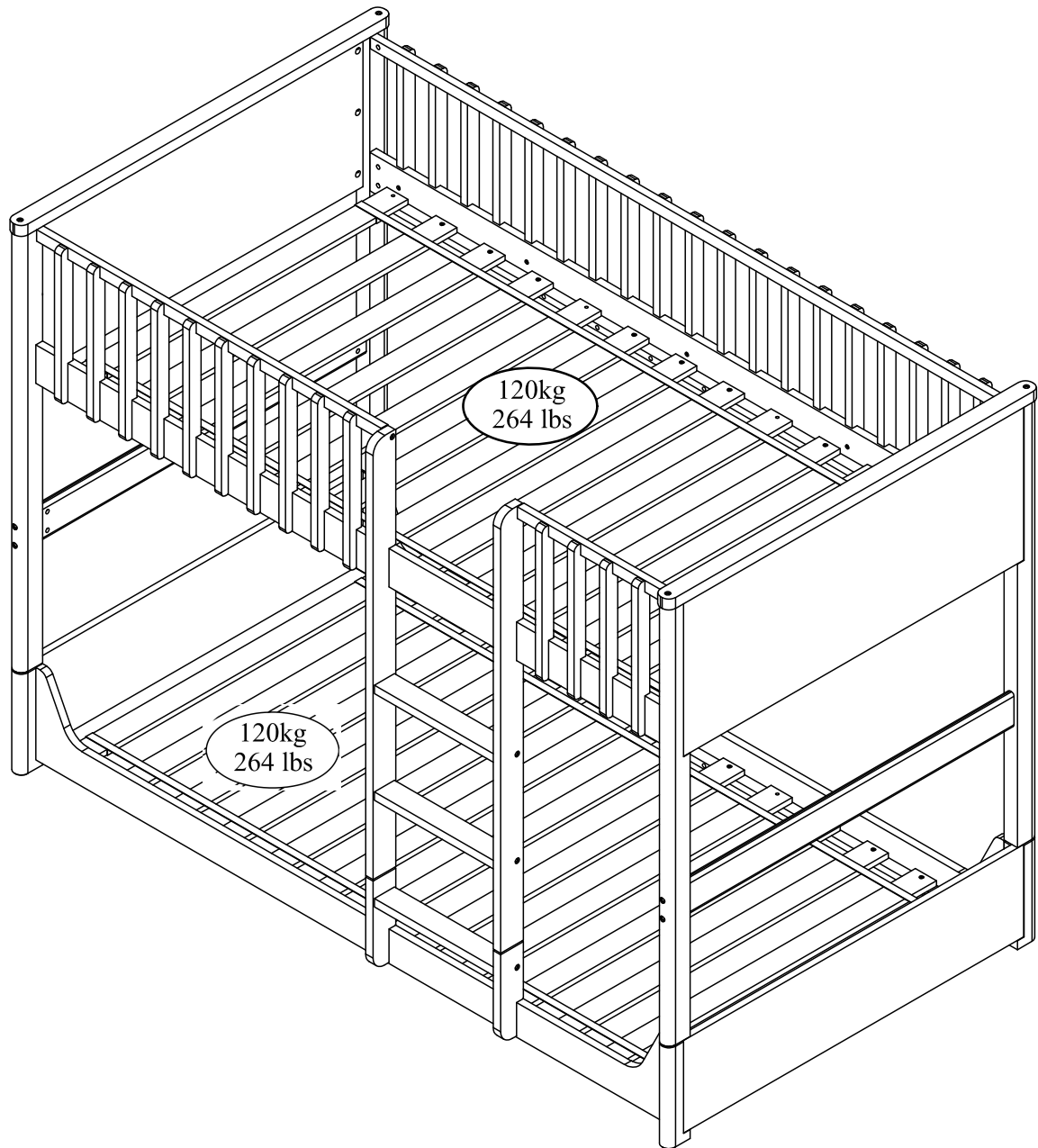

This product is designed to withstand the weight noted on the plan. We are not responsible for the breakage of parts or any injury caused by failure to comply with this recommendation.

Ce produit est conçu pour supporter le poids indiqué sur le plan. Nous ne sommes pas responsables de la casse de pièces ou toute blessure causée par le non-respect de cette recommandation.

Este producto está diseñado para soportar el peso indicado en el plano. No somos responsables de la rotura de piezas o cualquier lesión causada por el incumplimiento de esta recomendación.