



Assembly Instruction for

COFFEE TABLE







Caution: Please read instructions thoroughly before unpacking assembly parts. Sharp, exposed staple tips can cause injury, therefore, for your protection, please remove any exposed staples used in packing.

1. We recommend that you should assemble this product with the assistance of another person; this will make assembly easier, and will help to eliminate damage the product or injury to persons during assembly.
2. Be sure to check all packing materials carefully for small parts that may have come loose inside the carton during shipment.
3. Please do not over tighten screws or bolts .
4. Please put all parts on a non - abrasive floor before assembly, and follow the assembly steps to assemble your newly purchased product correctly and efficiently.

PARTS LIST

No	PARTS DESC.		Q'TY
A		TOP	1PC
B		LEG	3PCS
C		BOTTOM SHELF	1PC

HARDWARE LIST

No	HARDWARE DESC.		Q'TY.
1		BOLT 1/4"x 20mm	12PCS
2		SPRING WASHER Ø1/4"	12PCS
3		FLAT WASHER Ø1/4"	12PCS
4		ALLEN KEY 2-1/4"x4mm	1PC
5		ANGLE IRON	3PCS
6		SCREW Ø9"x12mm	12PCS
7		CASTER	3PCS

STEP 1

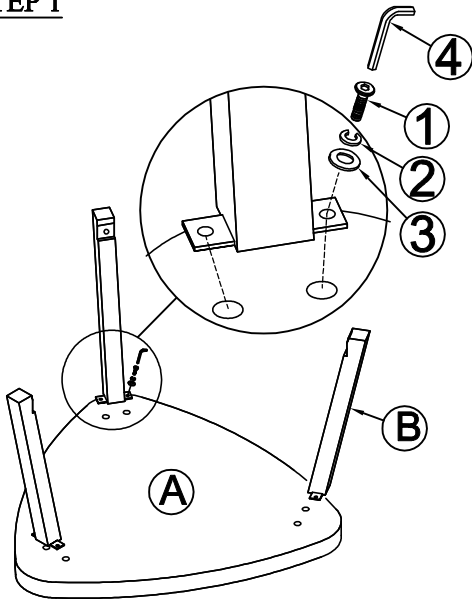

STEP 2

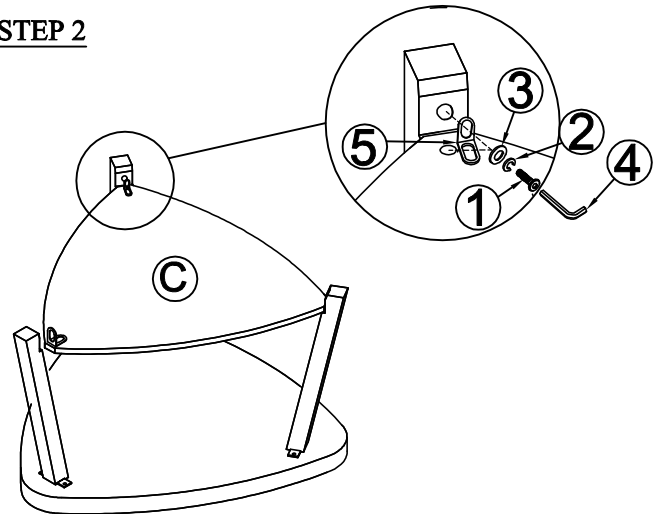

STEP 3

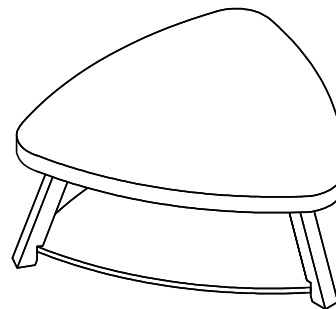
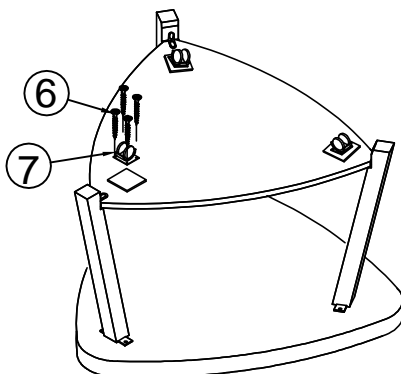

Assembly completed