

1**2****4****5****6****7****8****9**

1. To open, push upward on both buttons to unlock carrying handle.
 2. Place the opened case on the ground so it stands open with the underside of the table facing you and the handles facing out to each side.
 3. Pull seats out from the case and away from the table towards the handles.
 4. Pull the bracket that connects the table and seats towards you until the metal braces are in a straight line position to the bracket. Repeat for other side.
 5. Pull table legs out from seat. Repeat for other seat.
 6. Position the connecting braces on each of the seat legs so they form a straight line with the bracket.
 7. Turn table upright. Insert support ring.
 8. Ensure slide locks are engaged for all four legs.
 9. Ensure table/seat brackets are secured.
- To fold table back into carrying case, reverse the above instructions.

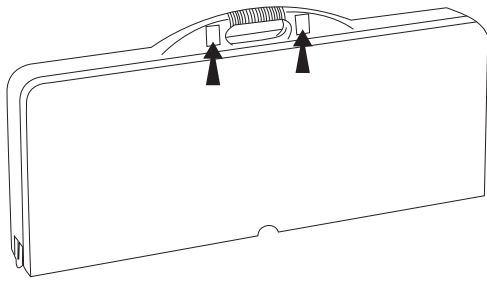
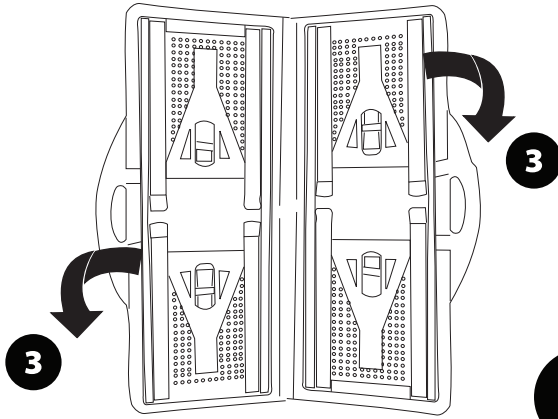
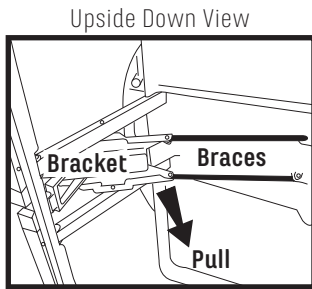
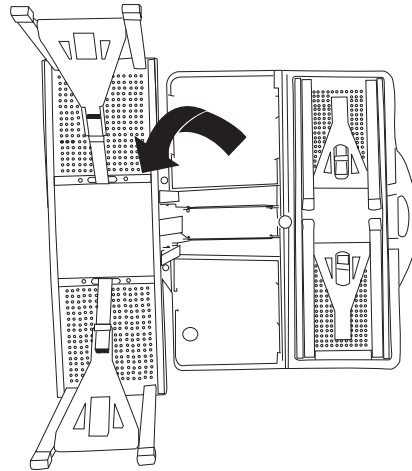
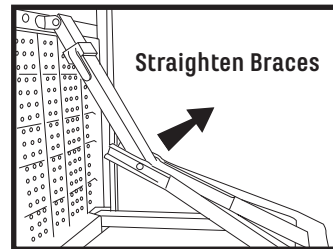
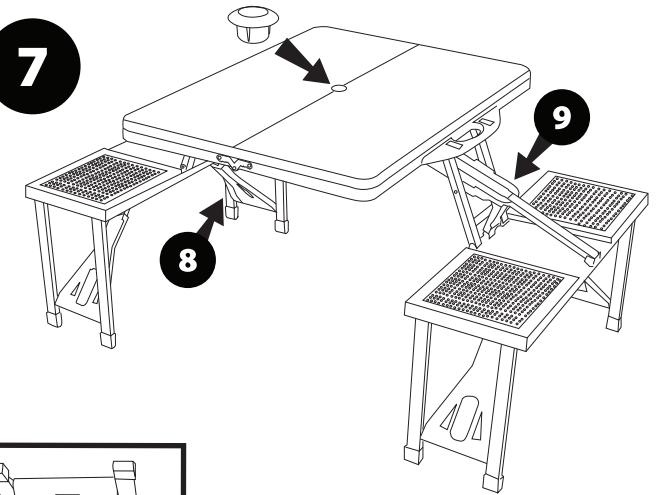
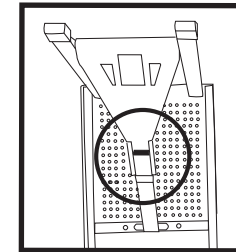
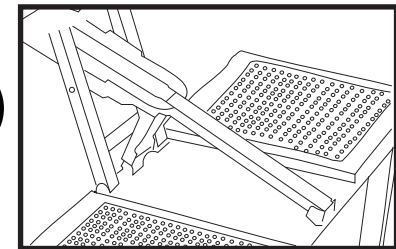