

# INSTALLATION & ASSEMBLY

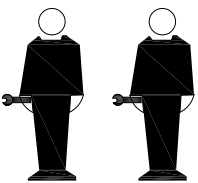

For convenience and safety, we recommend two people to assemble. If you have any questions, please contact our customer service.

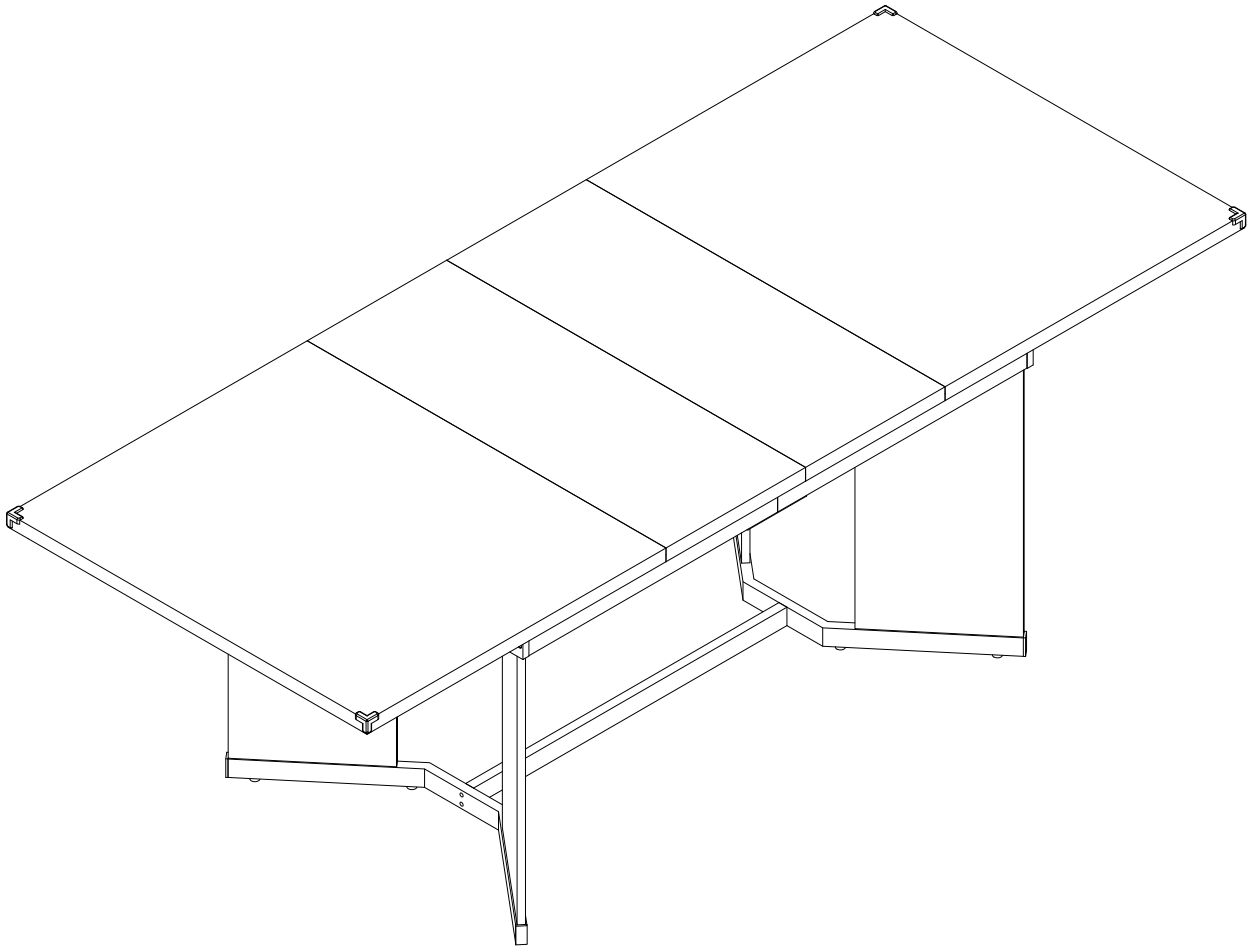
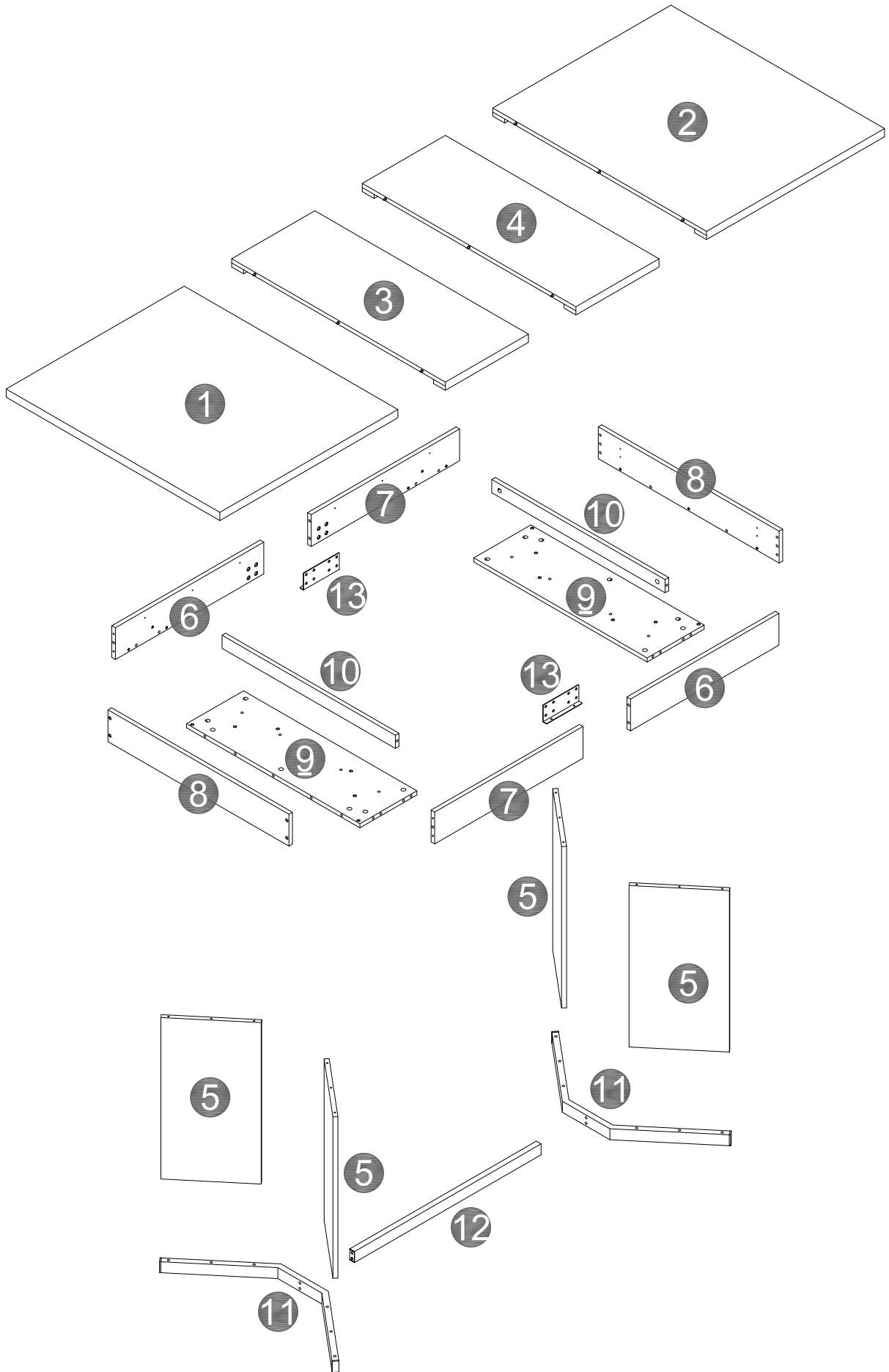

# PARTS LIST

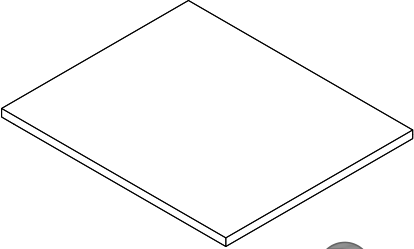
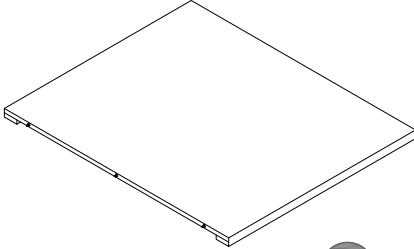
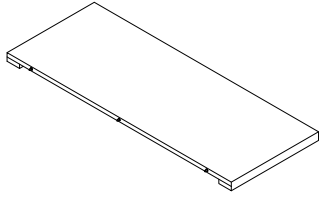
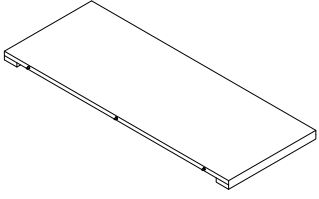
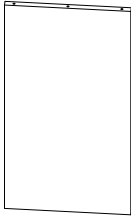
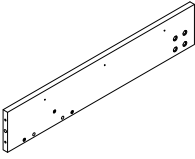
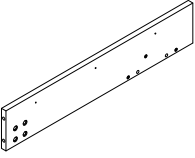
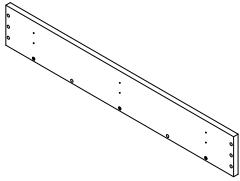
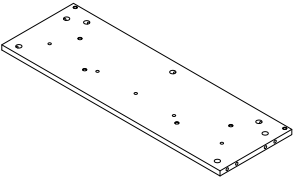
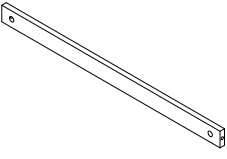
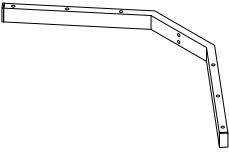
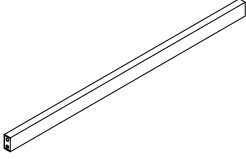
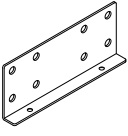
 <p>1 X1</p>	 <p>2 X1</p>	 <p>3 X1</p>
 <p>4 X1</p>	 <p>5 X4</p>	 <p>6 X2</p>
 <p>7 X2</p>	 <p>8 X2</p>	 <p>9 X2</p>
 <p>10 X2</p>	 <p>11 X2</p>	 <p>12 X1</p>
 <p>13 X2</p>		

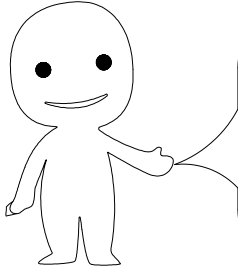

Please prepare the following tools

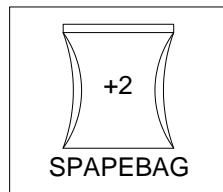
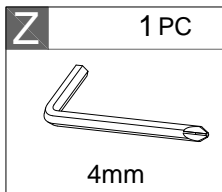
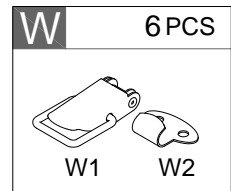
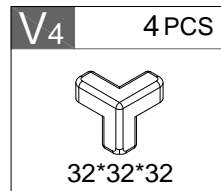
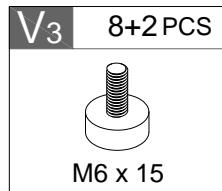
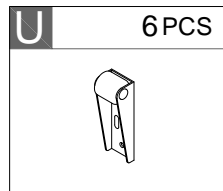
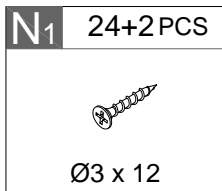
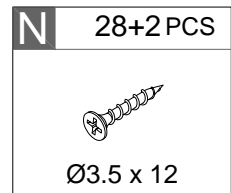
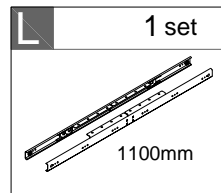
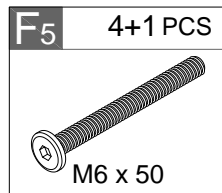
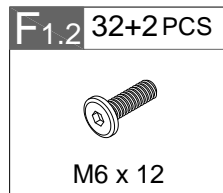
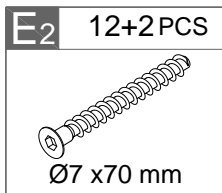
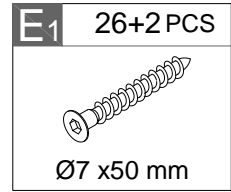
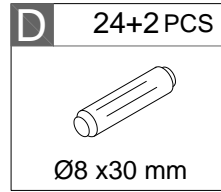
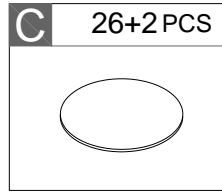
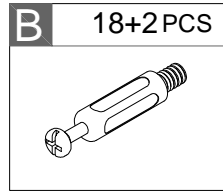
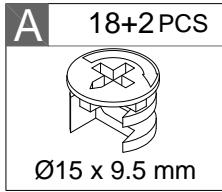
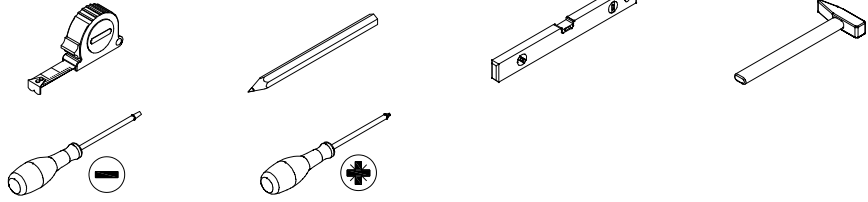

**Tips:** The number after "+" represents the spare hardware.

## IMPORTANT NOTES:

The item you are purchasing is a large furniture product that requires a large number of components to assemble.

Please take all parts boxes out of the packaging and place them in order. So that you can follow the steps in the installation manual to find the corresponding parts box and quantity of need when installing. Please do not take too many parts to prevent the parts from scattering.

Please be patient and follow the instructions step by step for installation. If you have any problems during the installation process, you can ask our customer service to help you solve them!

## SAFETY TIPS:

Static charge may cause dust on foam clean with a dry or damp cloth. Small foam strands may be present handle gently and dispose of properly. Do not burn or incinerate. Check local recycling guidelines.

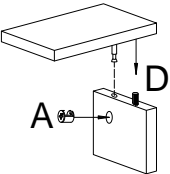
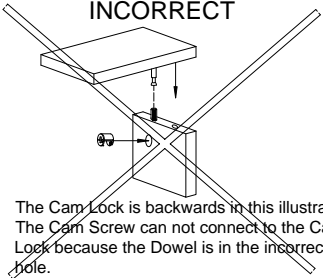
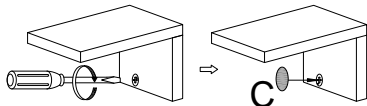
Cam Lock/Dowel Placement Supplement		
<p><b>CORRECT</b> 1</p>  <p>When inserting the Cam lock, make sure that the open End of the cam Lock faces the Cam Screw Entry. The Dowel will be inserted in the hole NEXT to the Cam Lock/Cam Screw hole.</p>	<p><b>INCORRECT</b> 2</p>  <p>The Cam Lock is backwards in this illustration. The Cam Screw can not connect to the Cam Lock because the Dowel is in the incorrect hole.</p>	<p>3</p>  <p>To tighten, turn the Cam Lock <b>CLOCKWISE</b> until the arrow or "△" signs point <b>AWAY</b> from the connected board.</p> <p><b>*NOTE: DO NOT USE AN AUTOMATIC SCREWDRIVER TO TIGHTEN CAM LOCKS, DO NOT OVER-TIGHTEN.</b></p>

**1**

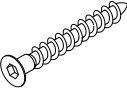
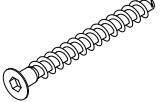
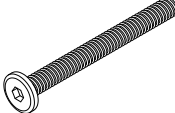
<b>E1</b>	12 PCS	<b>E2</b>	12 PCS	<b>F5</b>	4 PCS
					

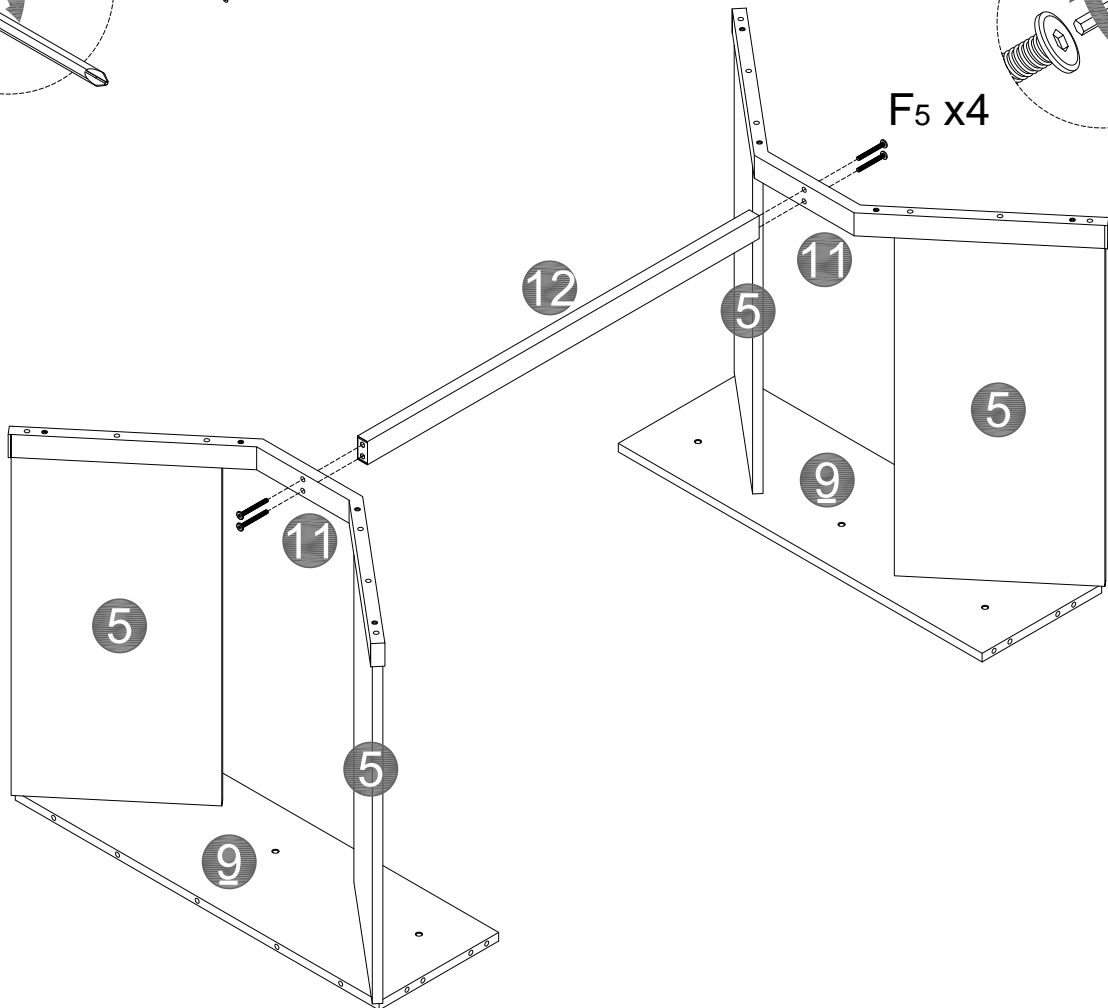
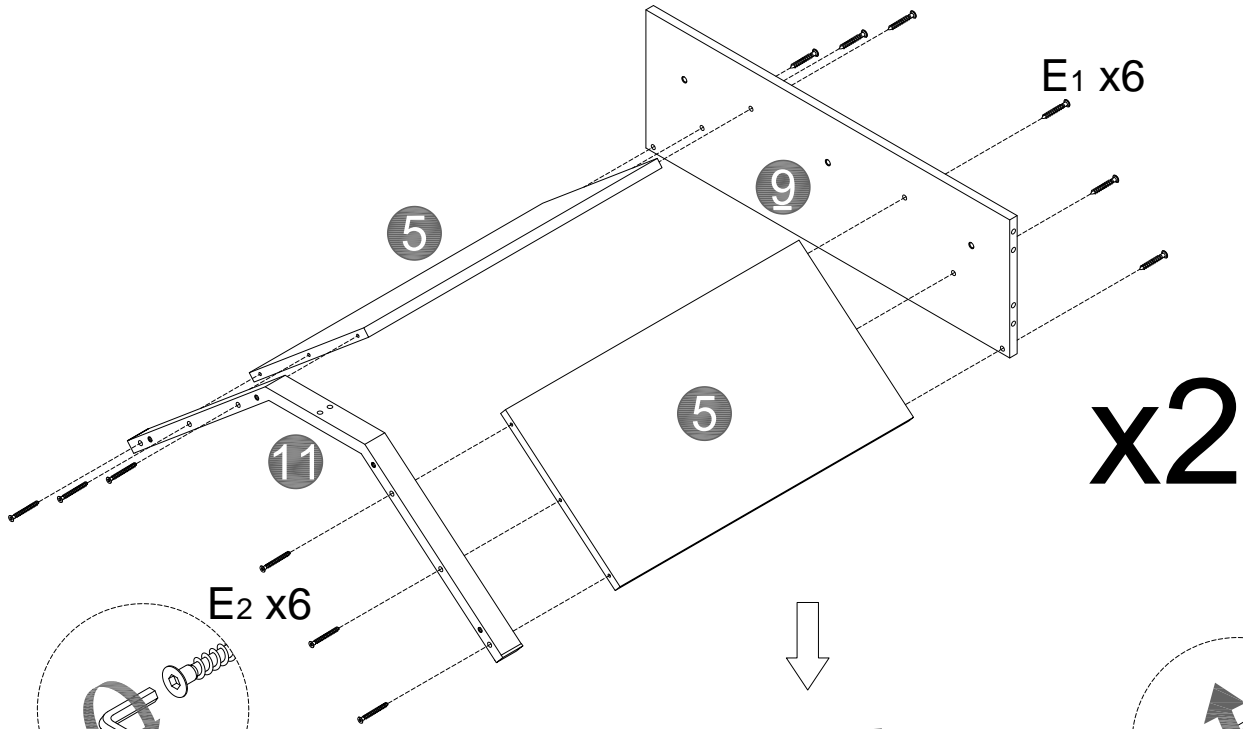

2

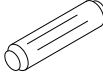
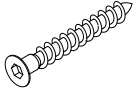
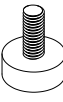
<b>D</b>	4 PCS	<b>E1</b>	6 PCS	<b>V3</b>	8 PCS
					

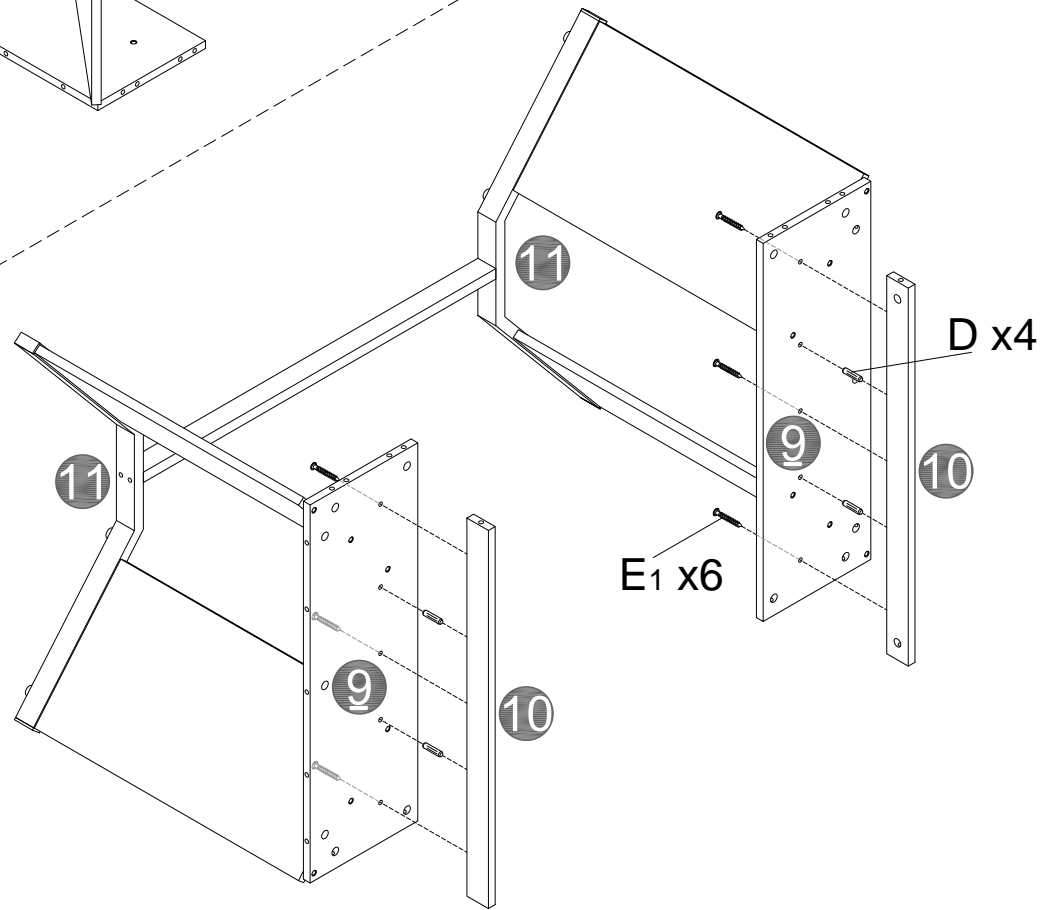
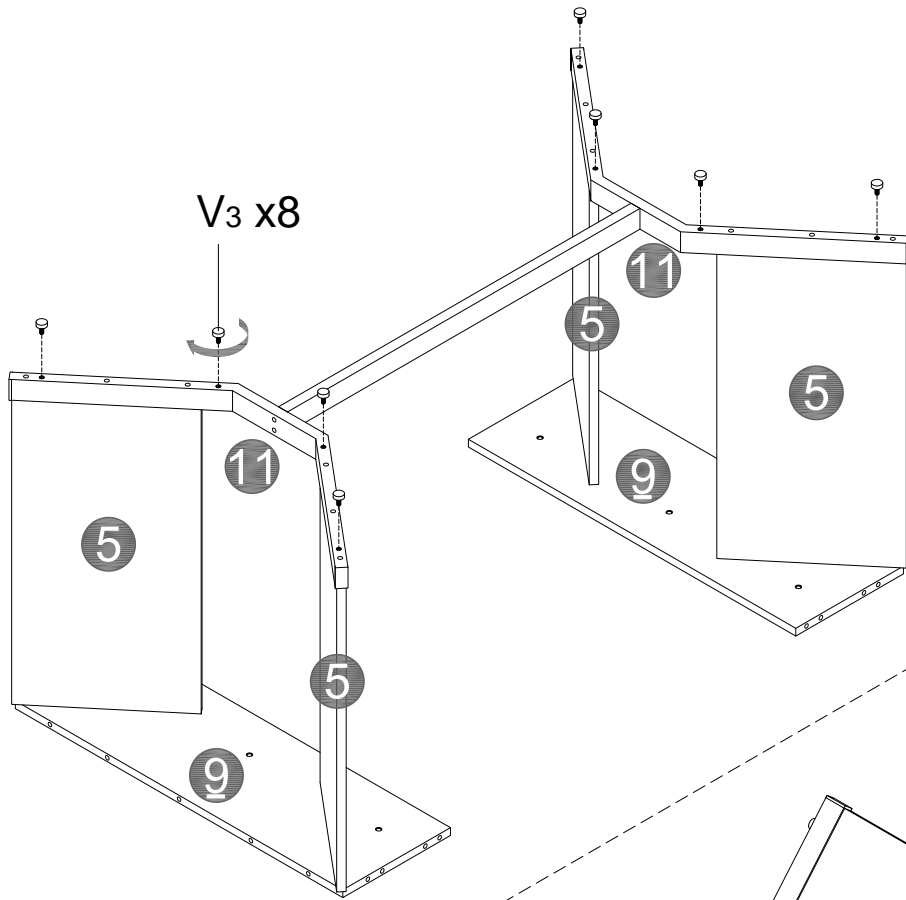

3

<b>B</b>	18PCS	<b>D</b>	4PCS	<b>F<sub>1.2</sub></b>	16PCS	<b>N</b>	16PCS	<b>U</b>	6PCS

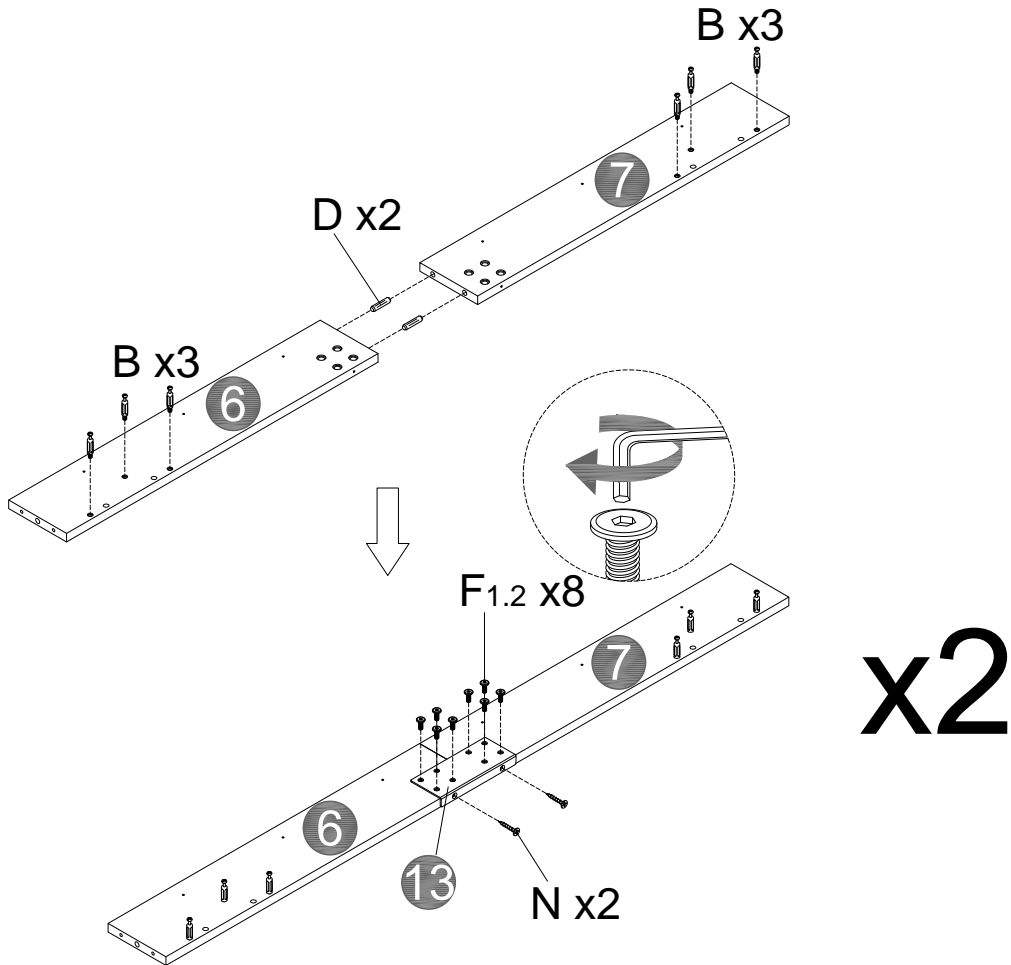
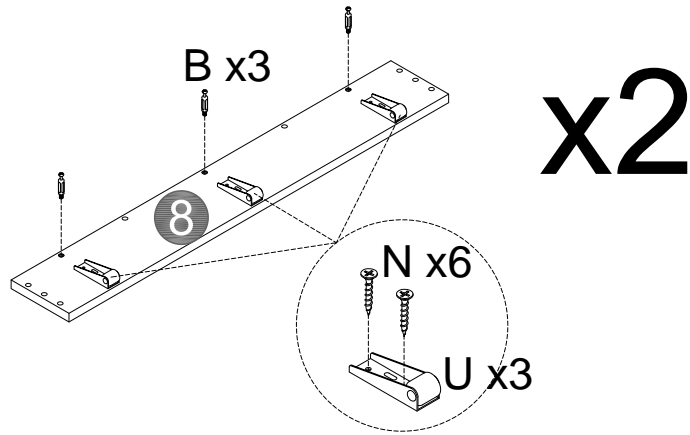
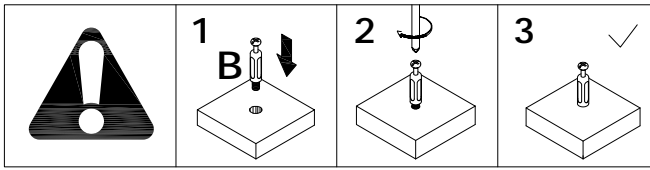

4

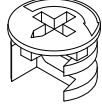
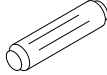
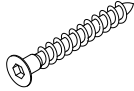
<b>A</b>	18PCS	<b>D</b>	16PCS	<b>E1</b>	8PCS
					

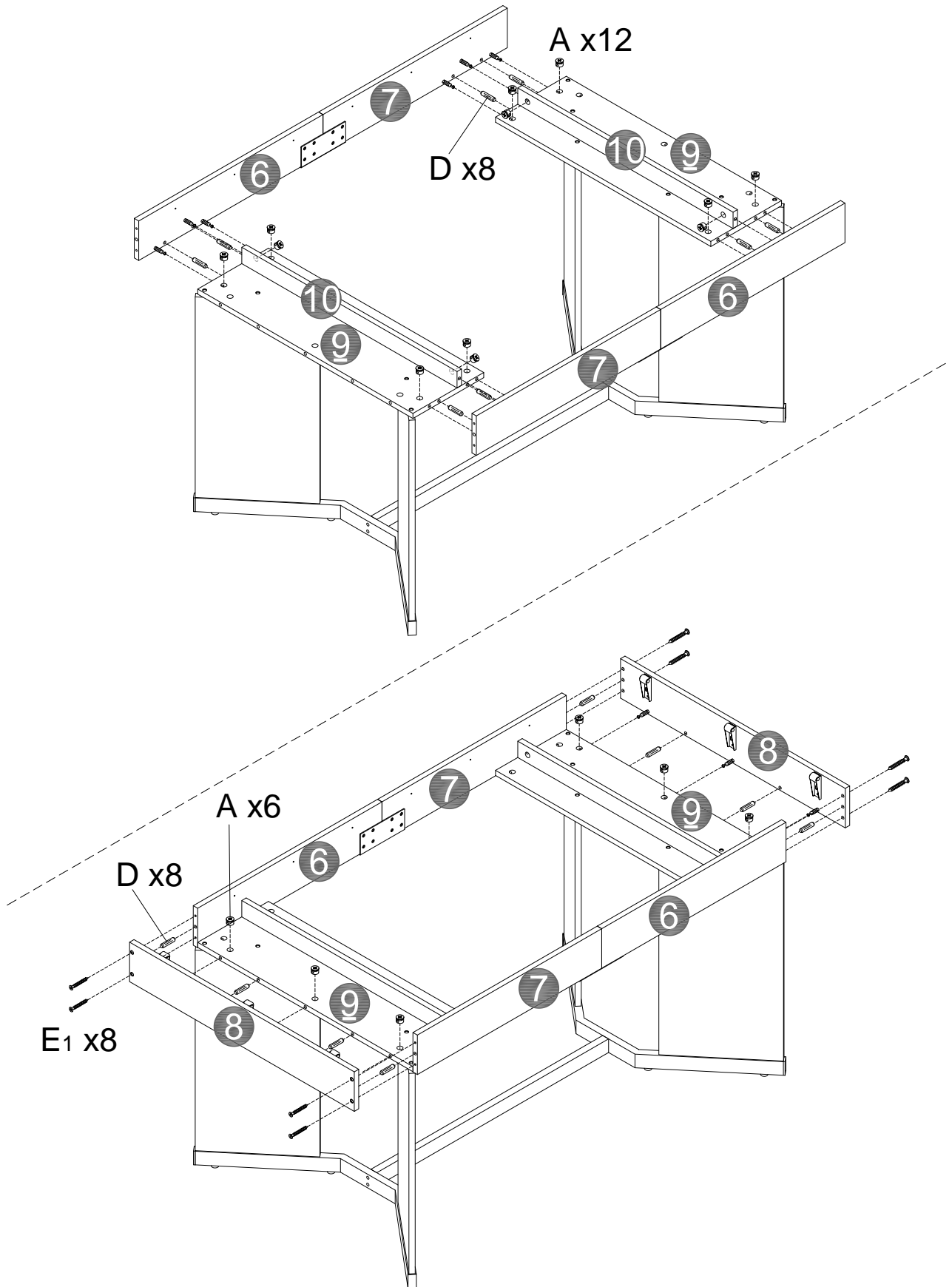

5

<b>L</b>	1 set	<b>N</b>	12 PCS	<b>N<sub>1</sub></b>	24 PCS	<b>W</b>	6 PCS
						W1 W2	

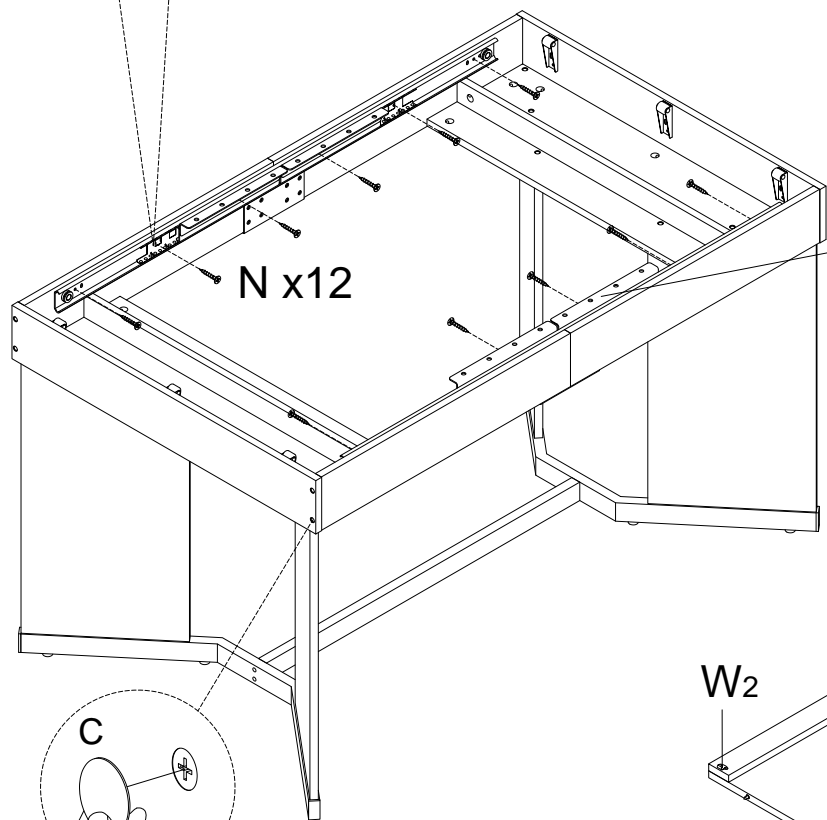
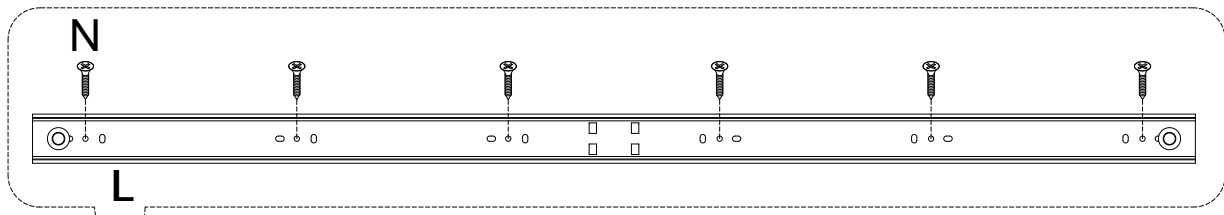

Slide Railx2  
Symmetrical installation

Attention 1: The TOP & Bottom are not the same, make sure you had find the difference

Attention 2: Align the slide rail with Part #L and install it at the reserved hole position

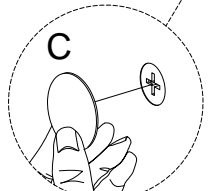

Place sticker (C) on the hole.

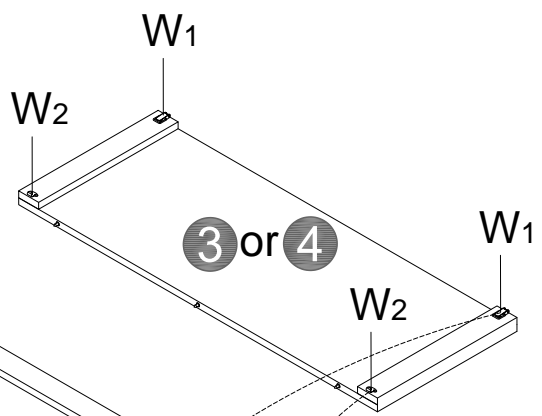

3 or 4

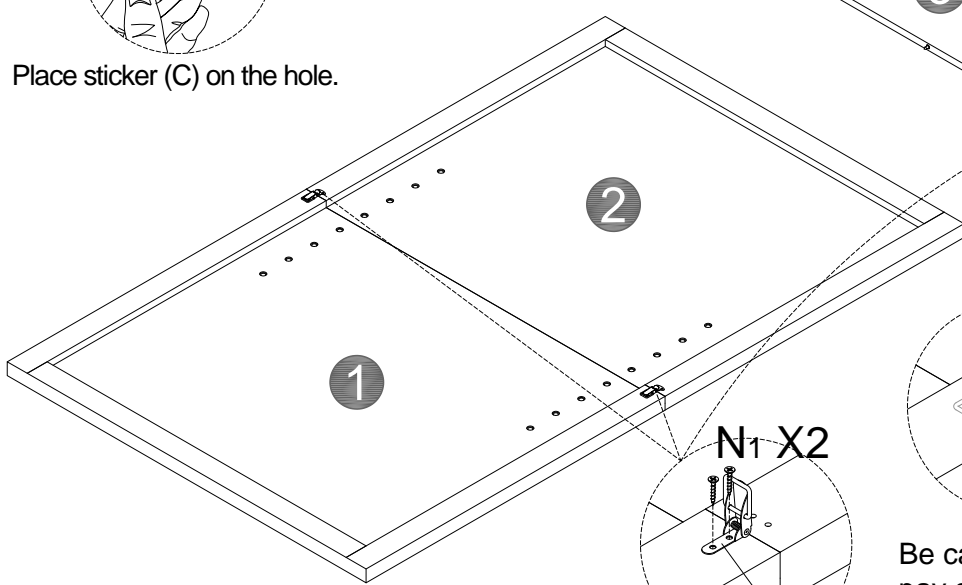

N<sub>1</sub> X2

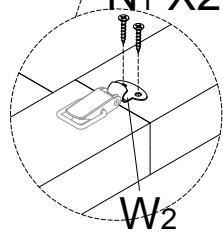

W<sub>2</sub>

Be careful to grip your hands and pay attention to the installation direction during the installation process

! Mind your hand



<b>F1.2</b>	<b>16PCS</b>	<b>V4</b>	<b>4PCS</b>

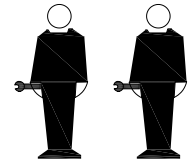

This step requires two people to complete

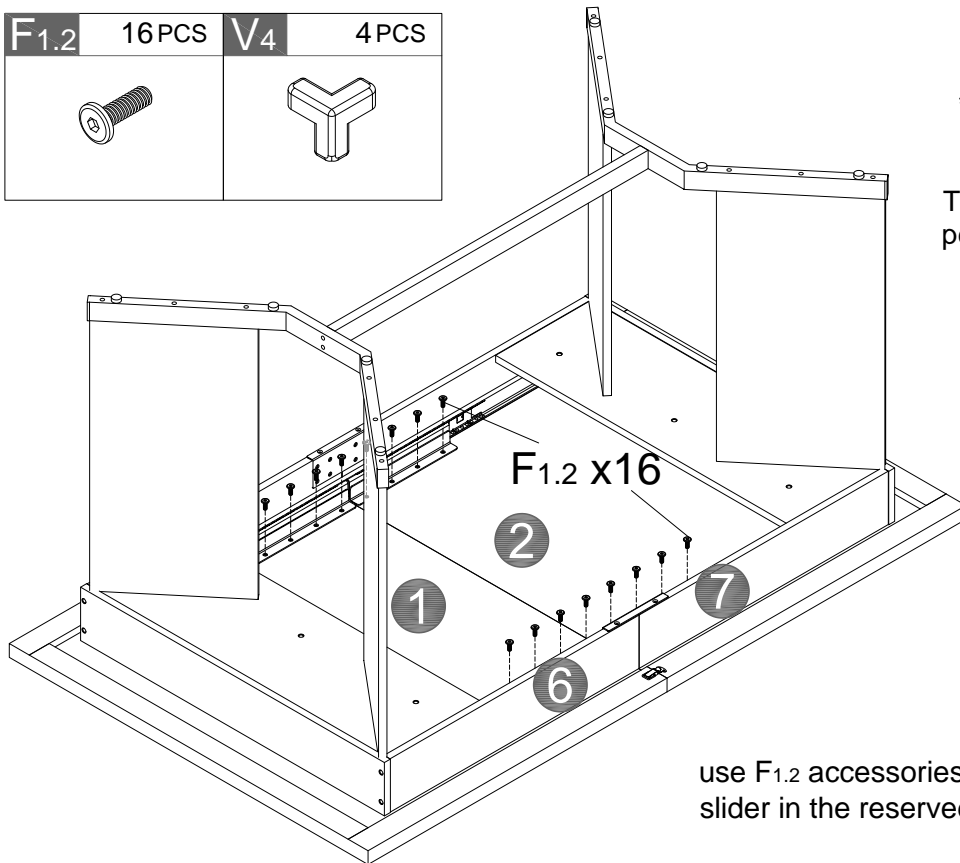

use F1.2 accessoriesto install the slider in the reservedholes

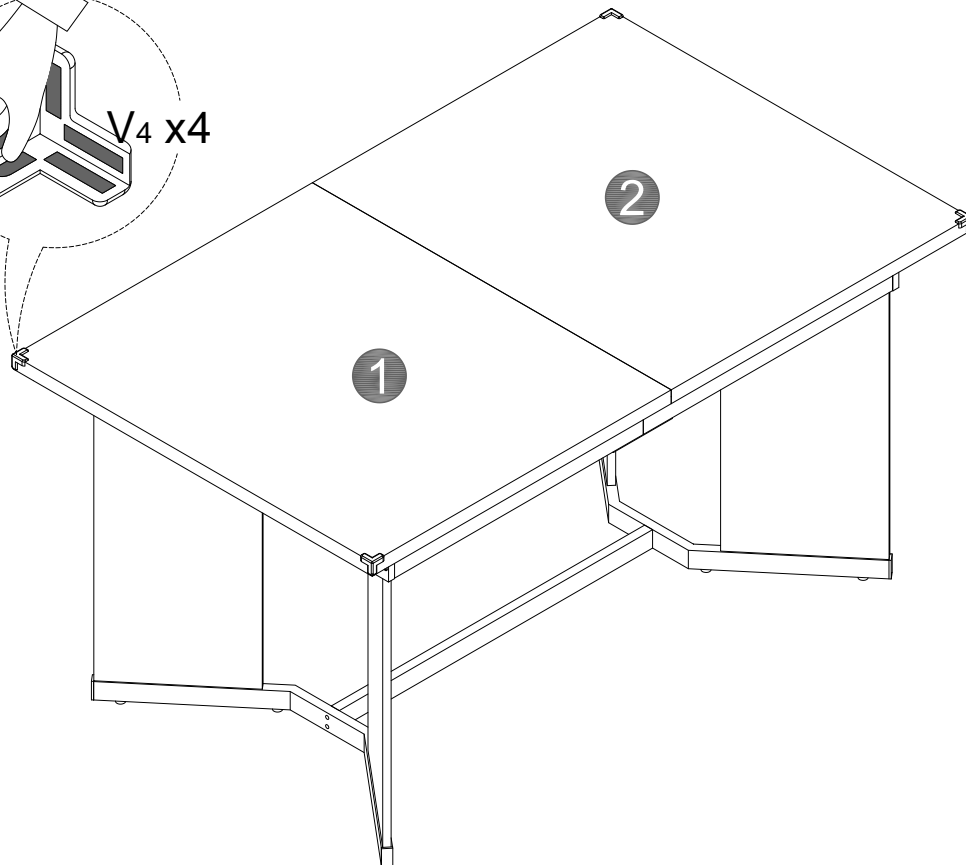
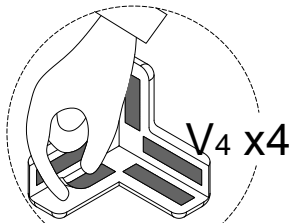
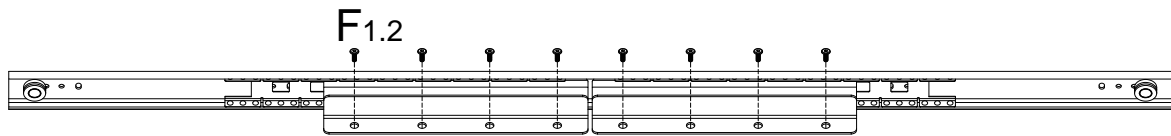

7

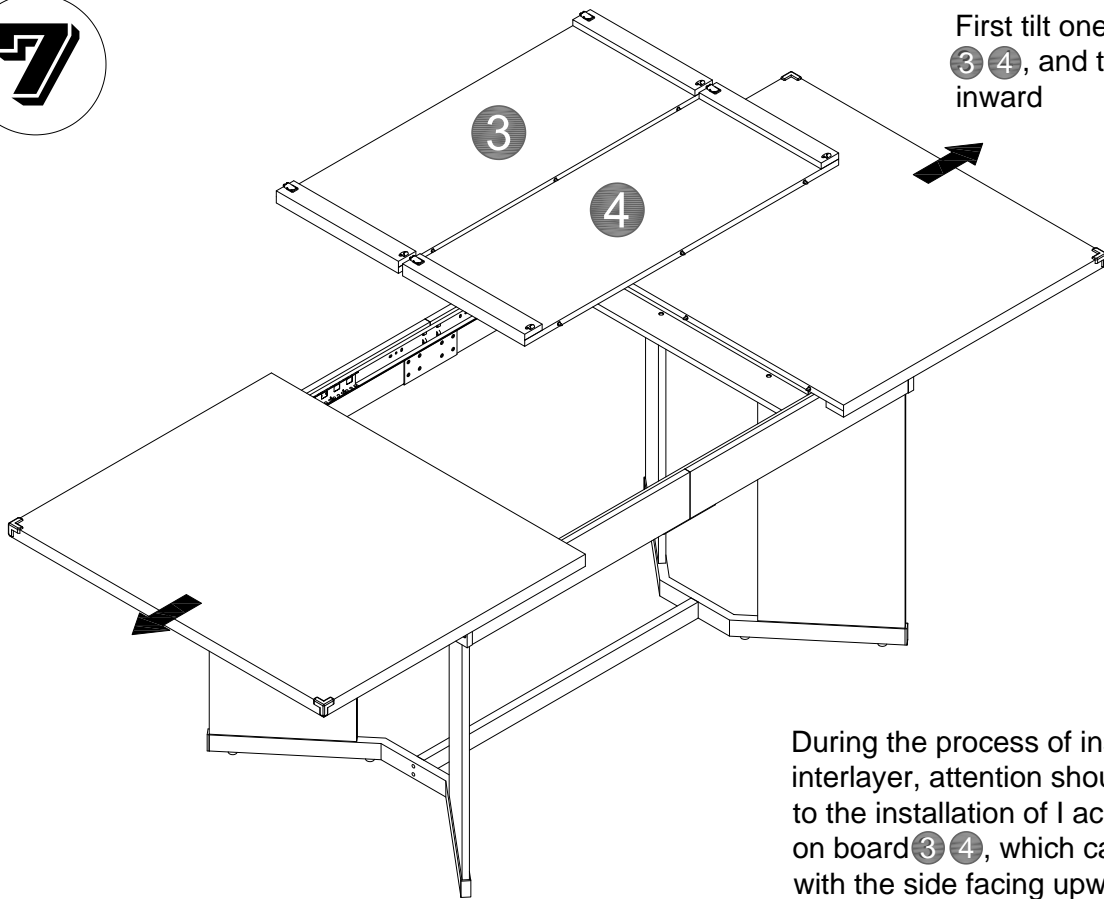

First tilt one side of board ③ ④, and then place it inward

During the process of inserting the interlayer, attention should be paid to the installation of I accessories on board ③ ④, which can be placed with the side facing upwards

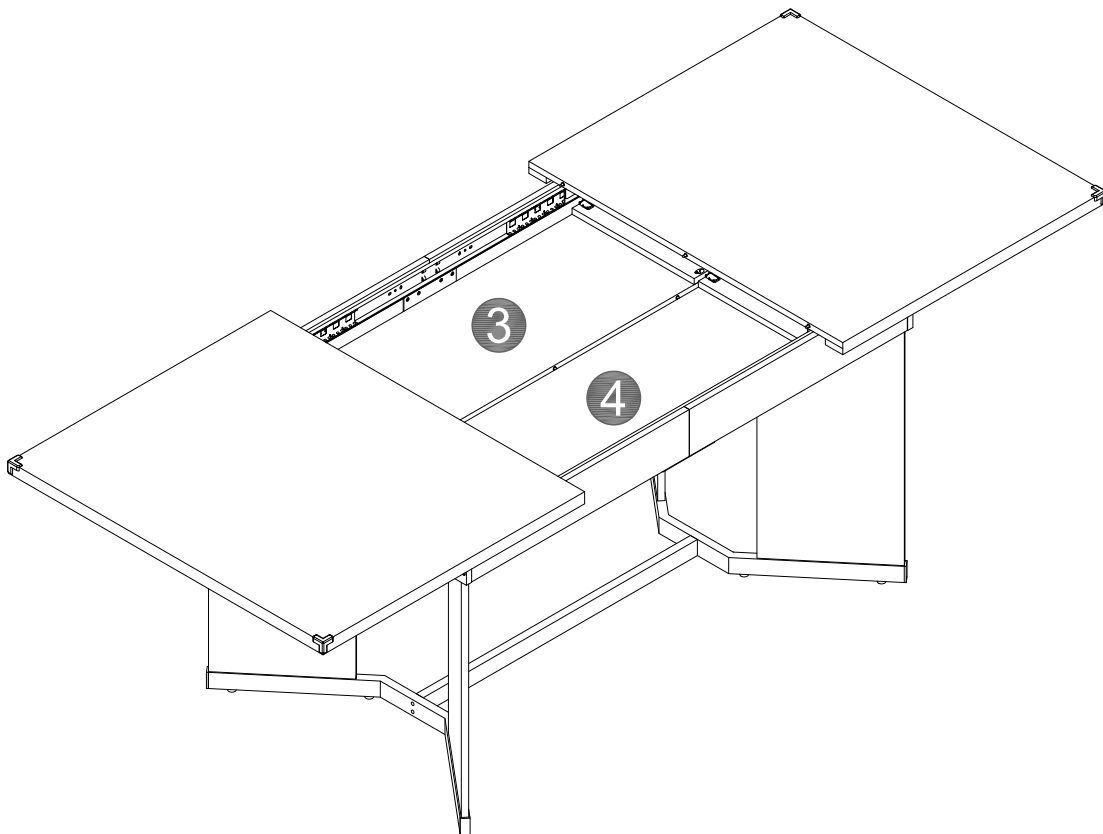

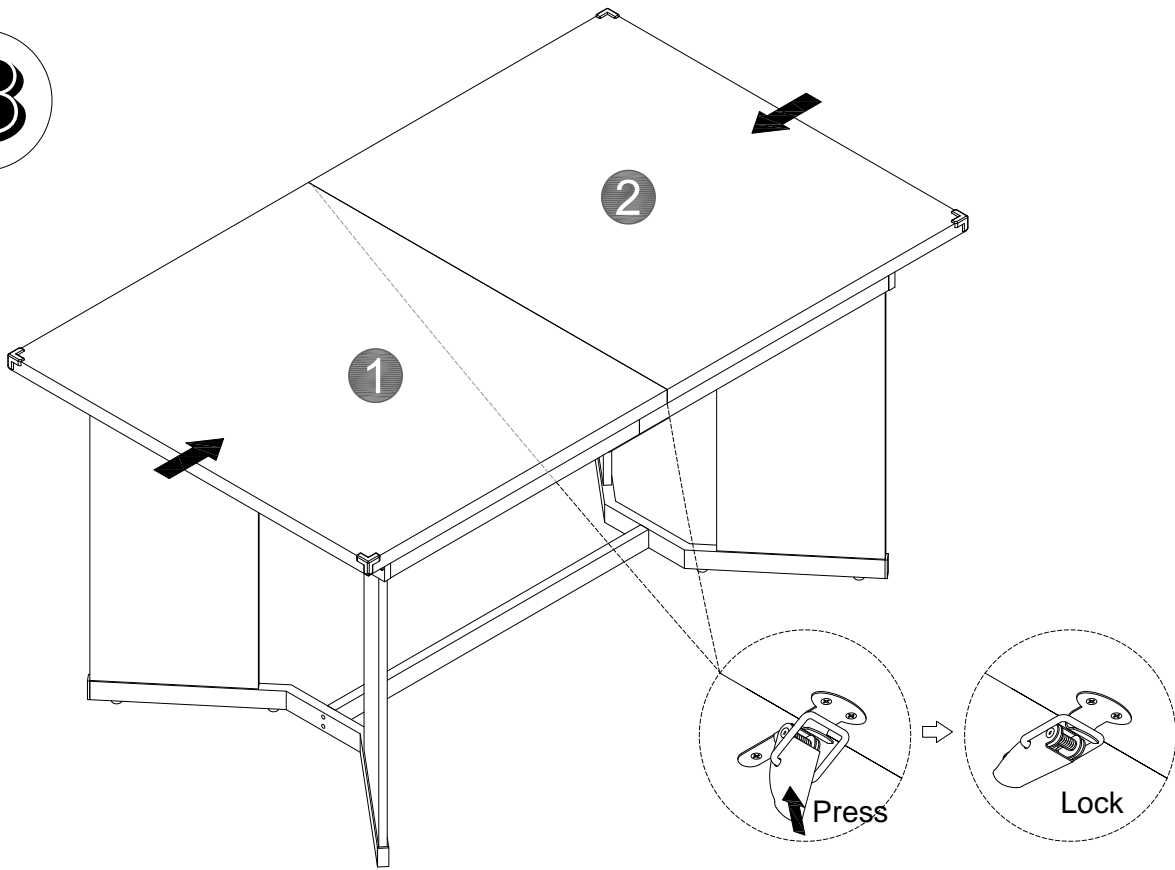

The first size installation is complete.

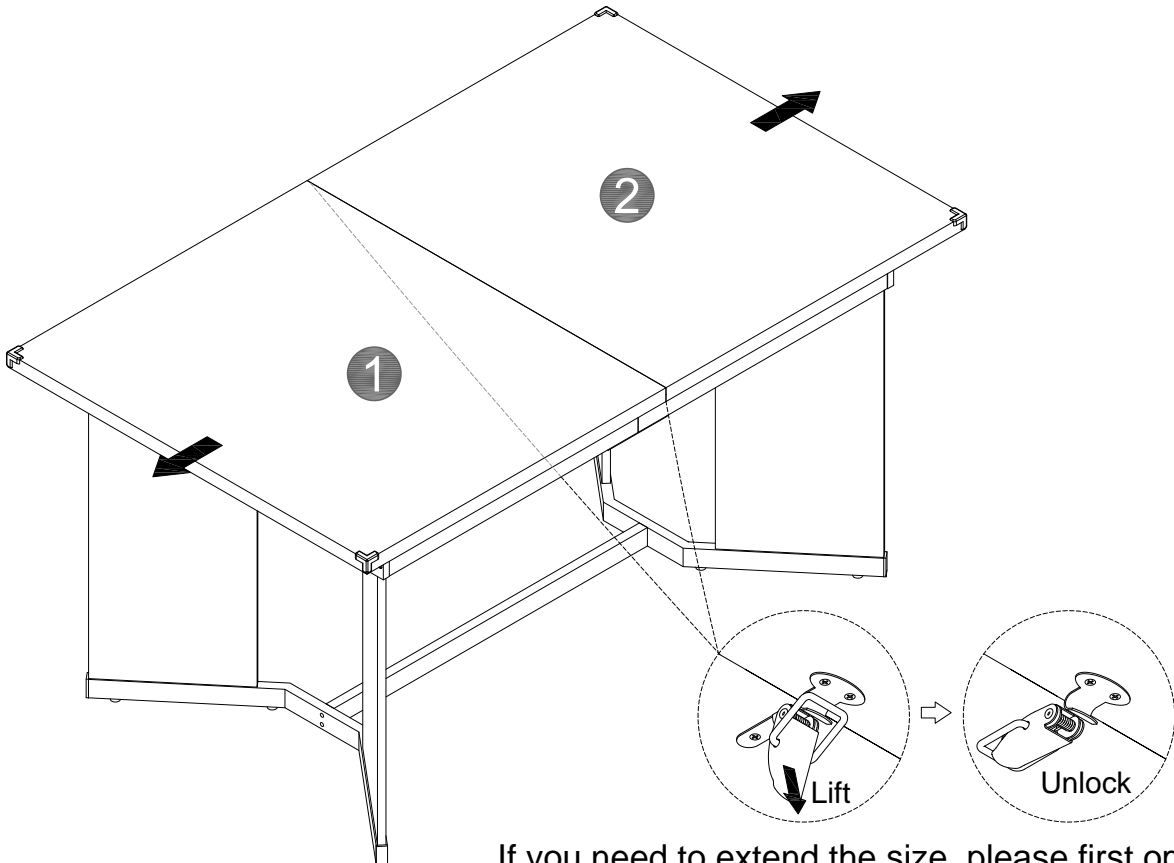

If you need to extend the size, please first open the buckle and take out the required board.



## Installation method of Extended Size 1

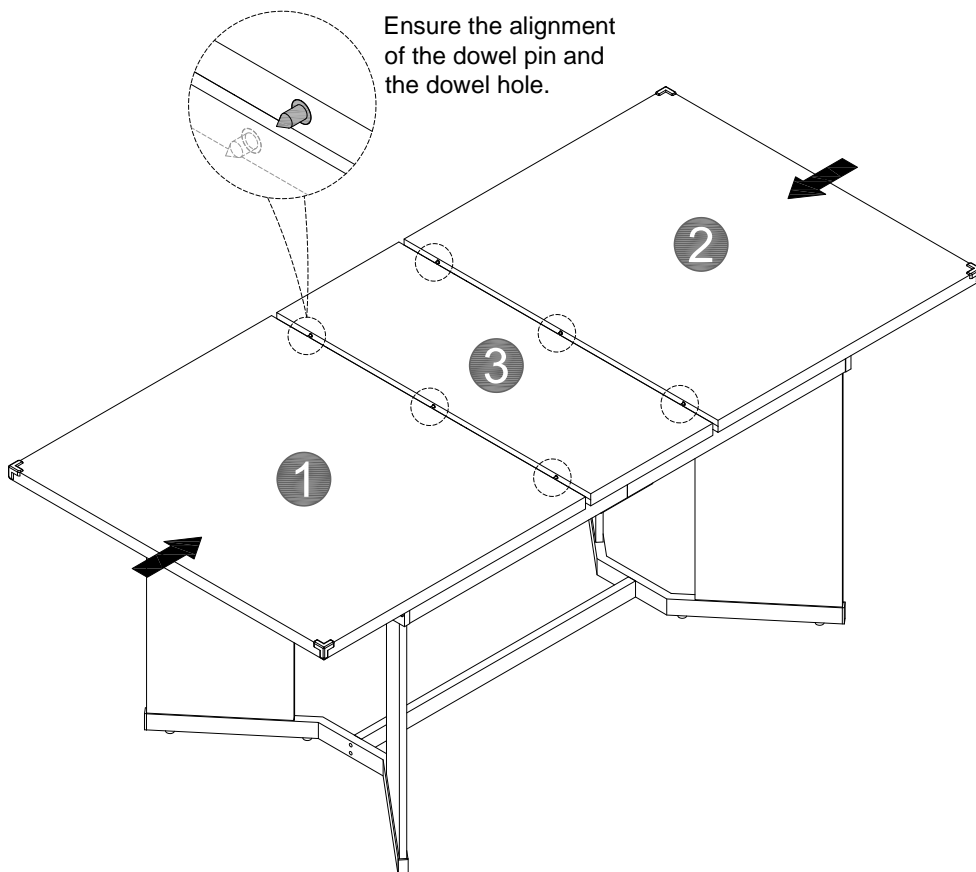
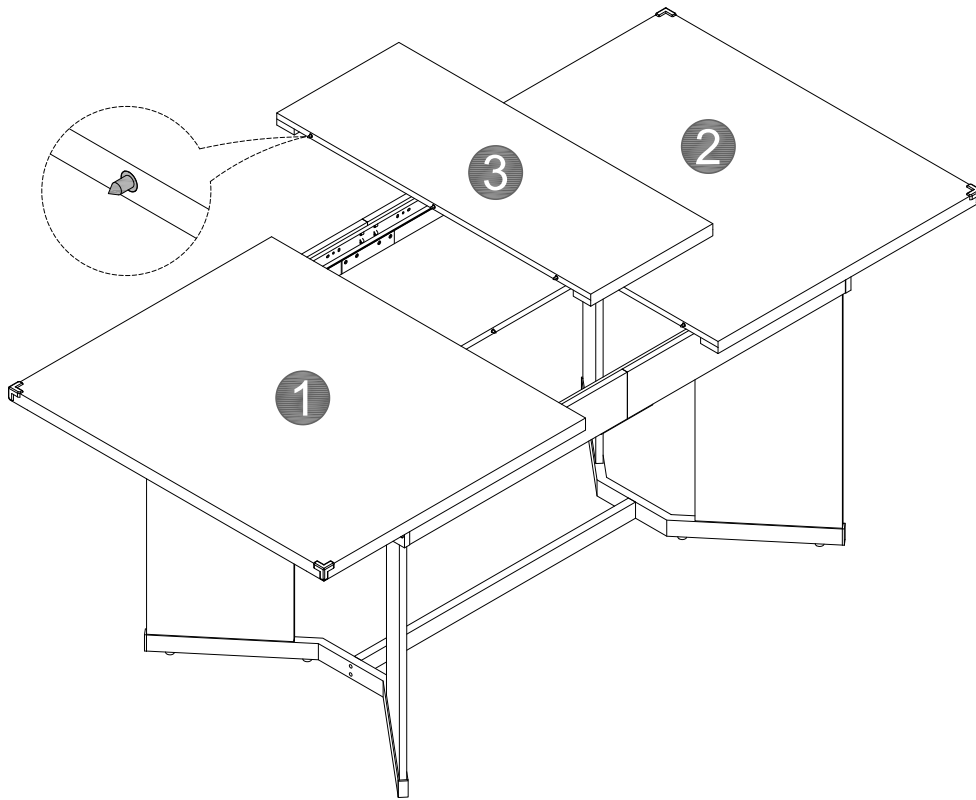

**10**

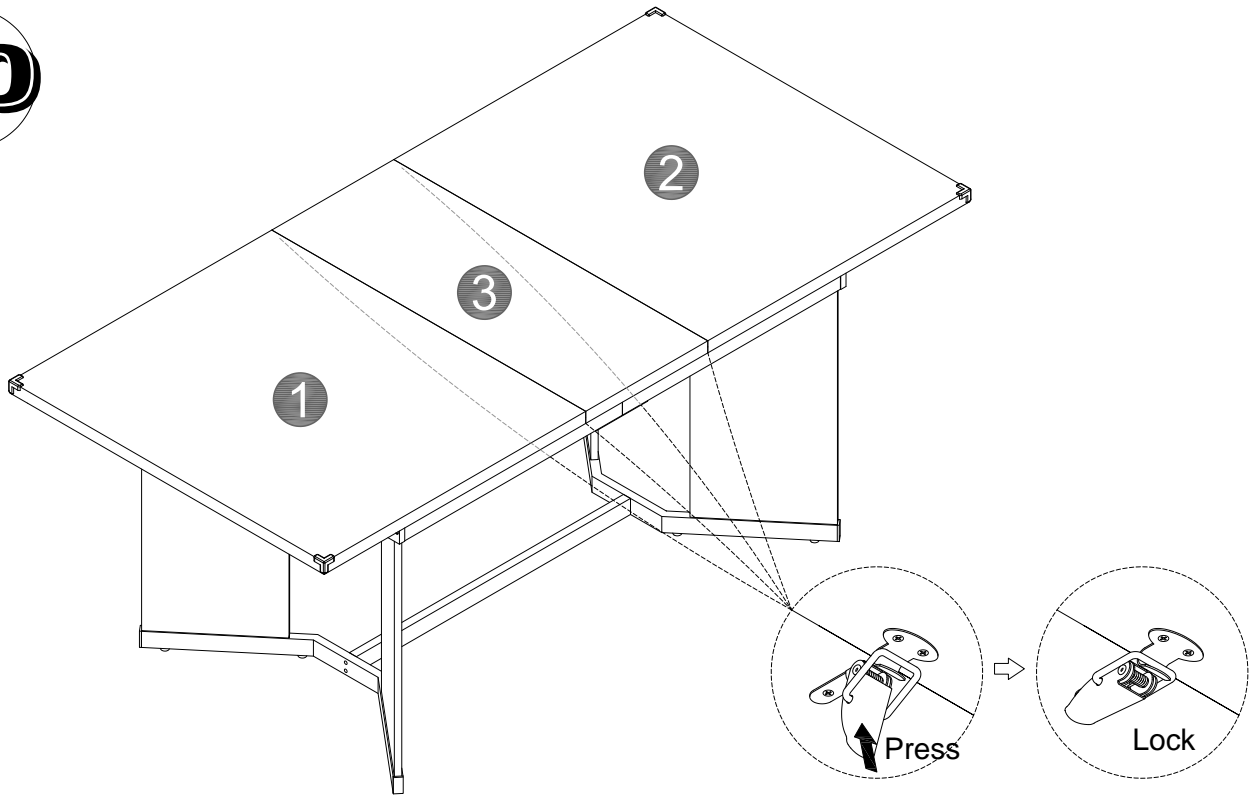

Extended Size 1 installation completed

---

Installation method of Extended Size 2

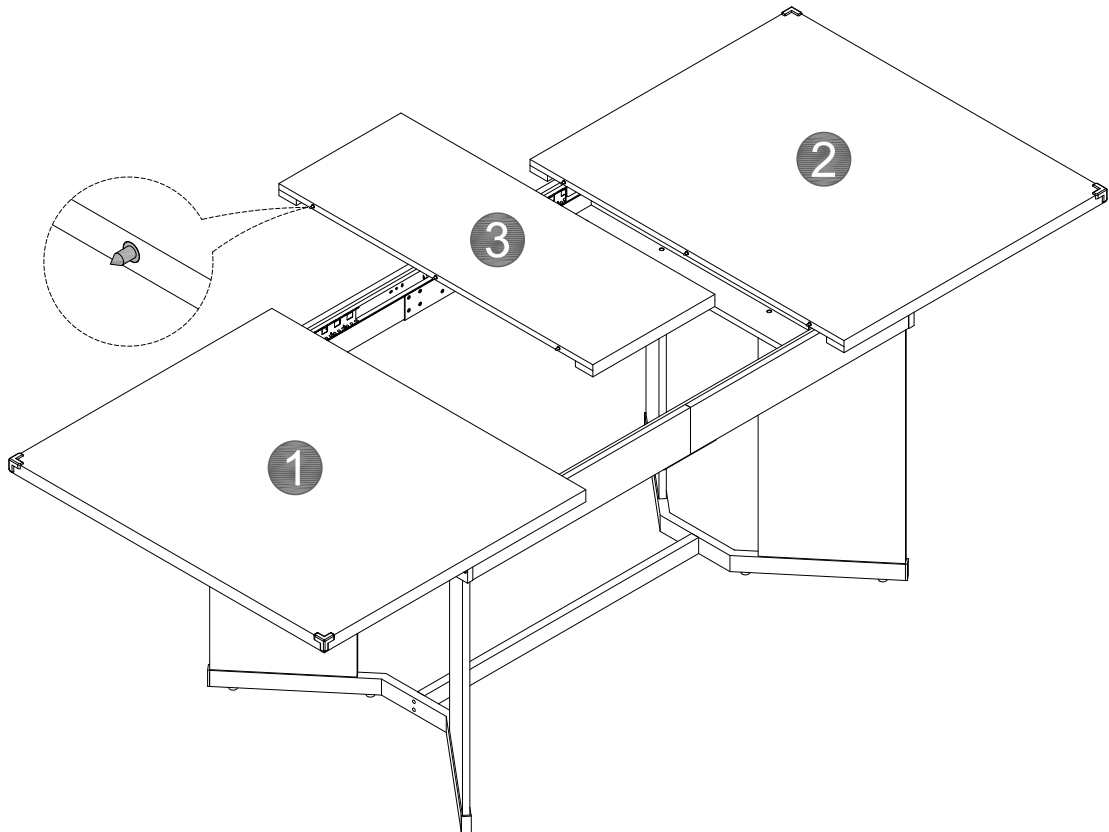

**1 1**

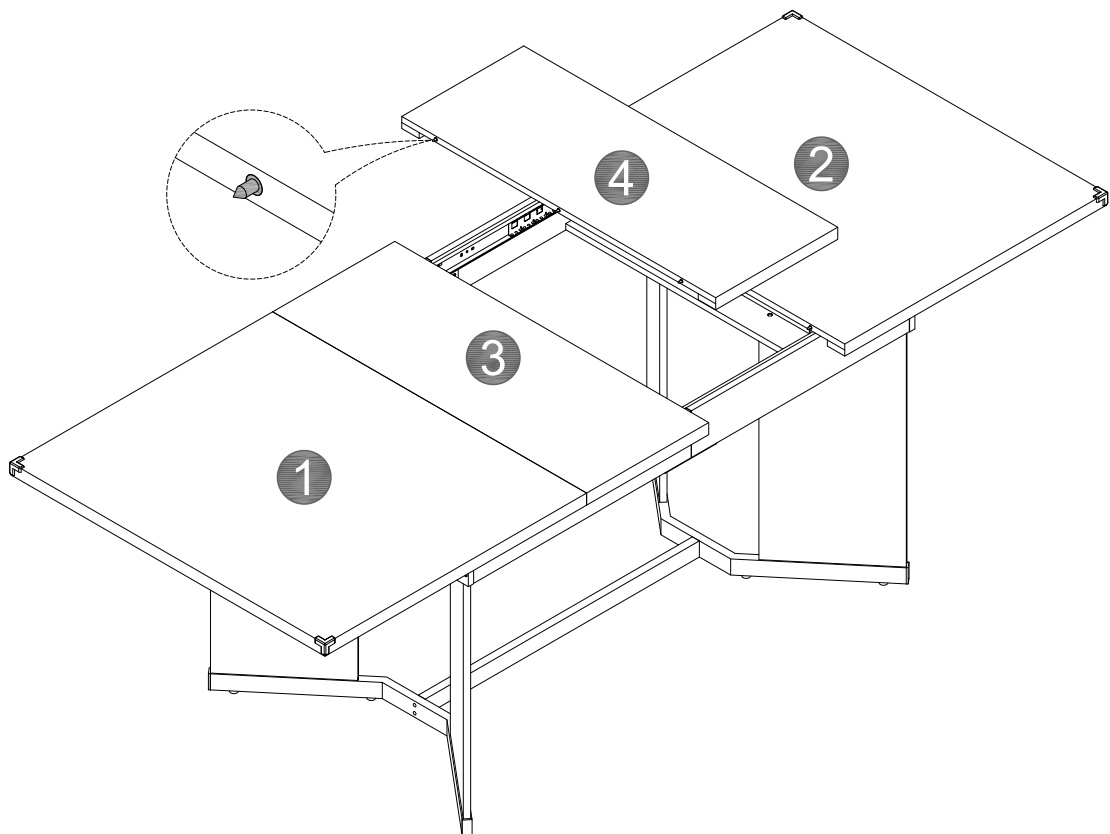
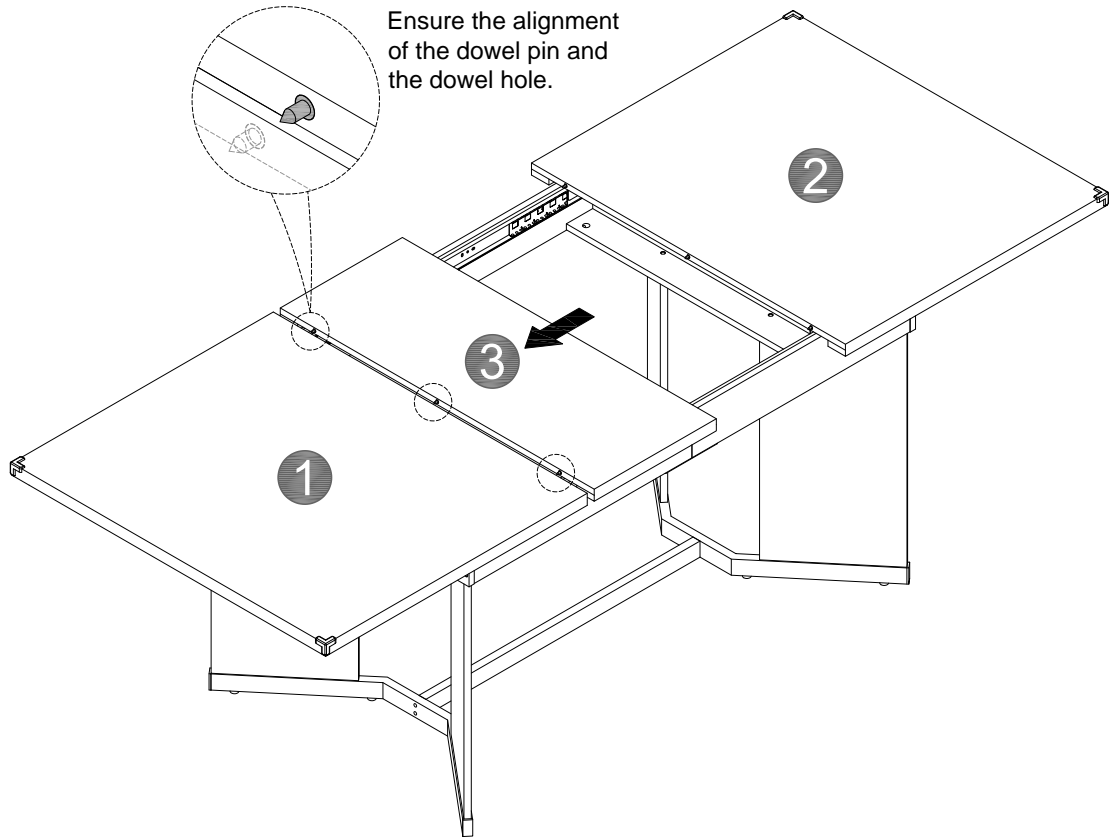

**12**

Ensure the alignment of the dowel pin and the dowel hole.

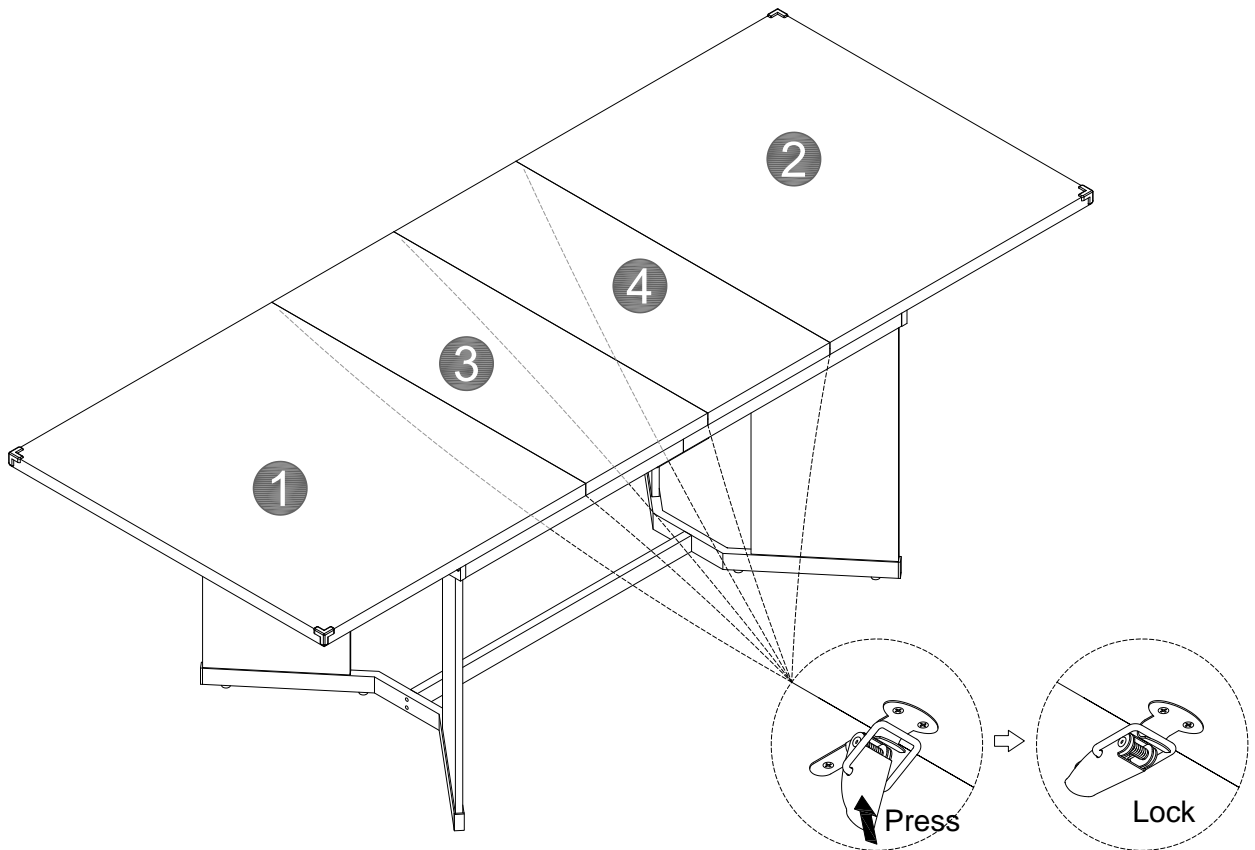
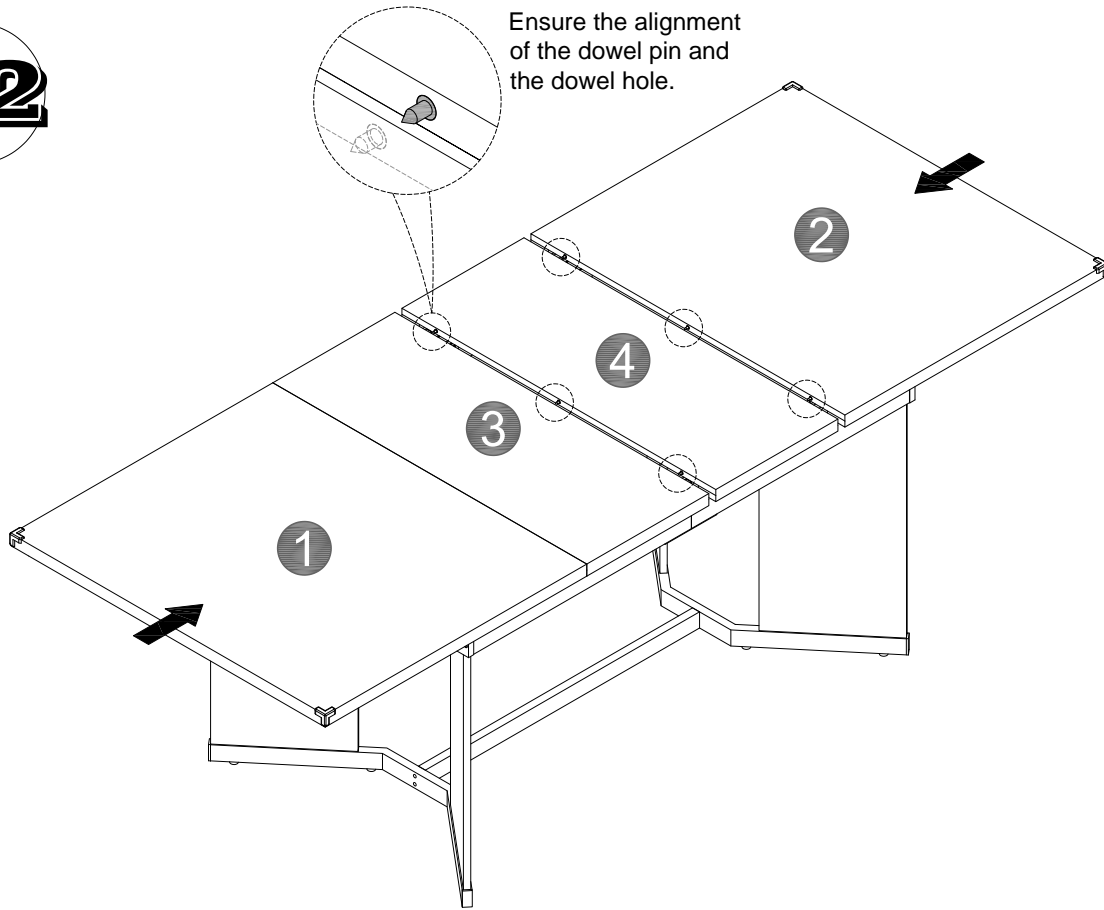

Extended Size 2 installation completed