

Important safety instructions:

- Please read carefully all instructions before assembly.
- For your safety and ease, assembly by two or more adults is recommended.
- Keep instructions for future use.



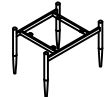

Pre-assembly:

- Do not discard any content until assembly is complete to avoid accidentally discarding small parts or hardware.
- Take out all parts and hardware from box.

Parts List

Item	Description	QTY
P1	Chair Top 	1
P2	Leg Frame 	1

Hardware List

Item	Description	QTY
H1	Bolts $\phi 1/4" \times 1" L$ 	4
H2	Lock Washers $\phi 1/4"$ 	4
H3	Flat Washers $\phi 1/4" \times 16mm$ 	4
H4	Allen Wrench $\phi 1/4"$ 	1

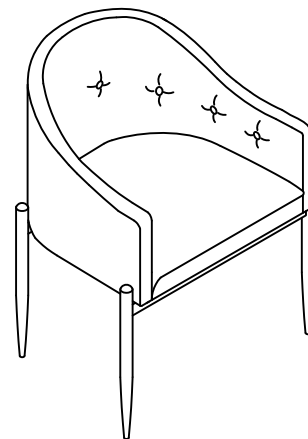

DISCLAIMER:

WHEN PROPERLY ASSEMBLED, THIS ITEM IS SAFE FOR INTENDED USE. SELLER IS NOT LIABLE FOR ANY DAMAGES RESULTING FROM ITEM BEING IMPROPERLY ASSEMBLED AFTER PURCHASE.

Assembly Procedures:

Step 1: Assemble the chair on a flat, soft surface such as a carpet or cloth to prevent scratching the finish. Attach the leg frame (P2) to the bottom of chair top (P1) as shown below.

(H1)x4 Bolts $\phi 1/4" \times 1" L$

(H2)x4 Lock Washers $\phi 1/4"$

(H3)x4 Flat Washers $\phi 1/4" \times 16mm$

(H4)x1 Allen Wrench $\phi 1/4"$

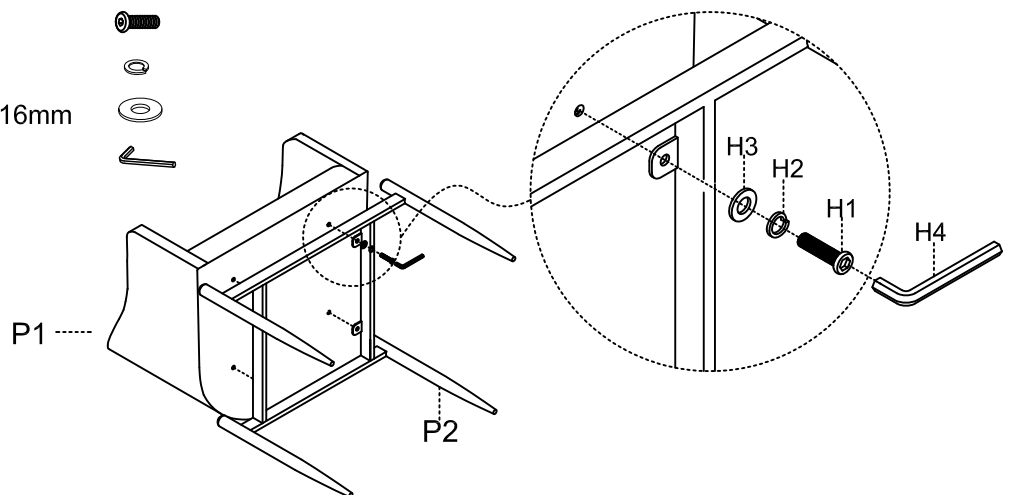

Step 2. Securely tighten all bolts with Allen wrench(H4), turn the assembled chair to an upright position, make sure the chair is level, aligned properly. Assembly is complete. **Failure to follow these instructions may cause the bolts to misalign during assembly.**

ADDITIONAL NOTE ABOUT SAFETY: BOLTS MAY LOOSEN DURING NORMAL EVERYDAY USE. THEY SHOULD BE PERIODICALLY INSPECTED AND RE-TIGHTENED TO PREVENT DAMAGE OR INJURY. ALWAYS CHECK TO ENSURE THAT ALL HARDWARE IS KEPT TIGHTENED.

Thank you for your purchase