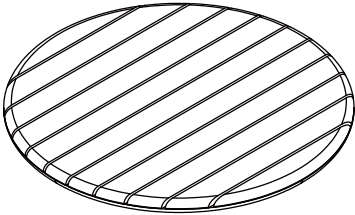
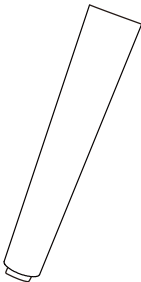
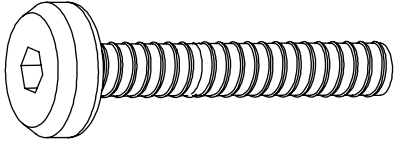
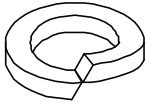
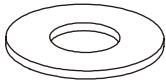
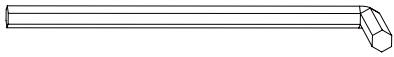

# Assembly Instructions

NUMBER	COMPONENT	QUANTITY
A	 <p data-bbox="970 815 1171 864">Table top</p>	1PC
B	 <p data-bbox="1023 1256 1118 1305">Legs</p>	4PCS

# Assembly Instructions

NUMBER	COMPONENT	QUANTITY
C	 <p data-bbox="863 786 1171 831">Bolt M6x50mm</p>	8PCS
D	 <p data-bbox="852 1234 1179 1279">M6 lock washer</p>	8PCS
E	 <p data-bbox="863 1682 1171 1727">M6 flat washer</p>	8PCS
F	 <p data-bbox="919 2119 1115 2163">Allen key</p>	1PC

# Assembly Instructions

**1**

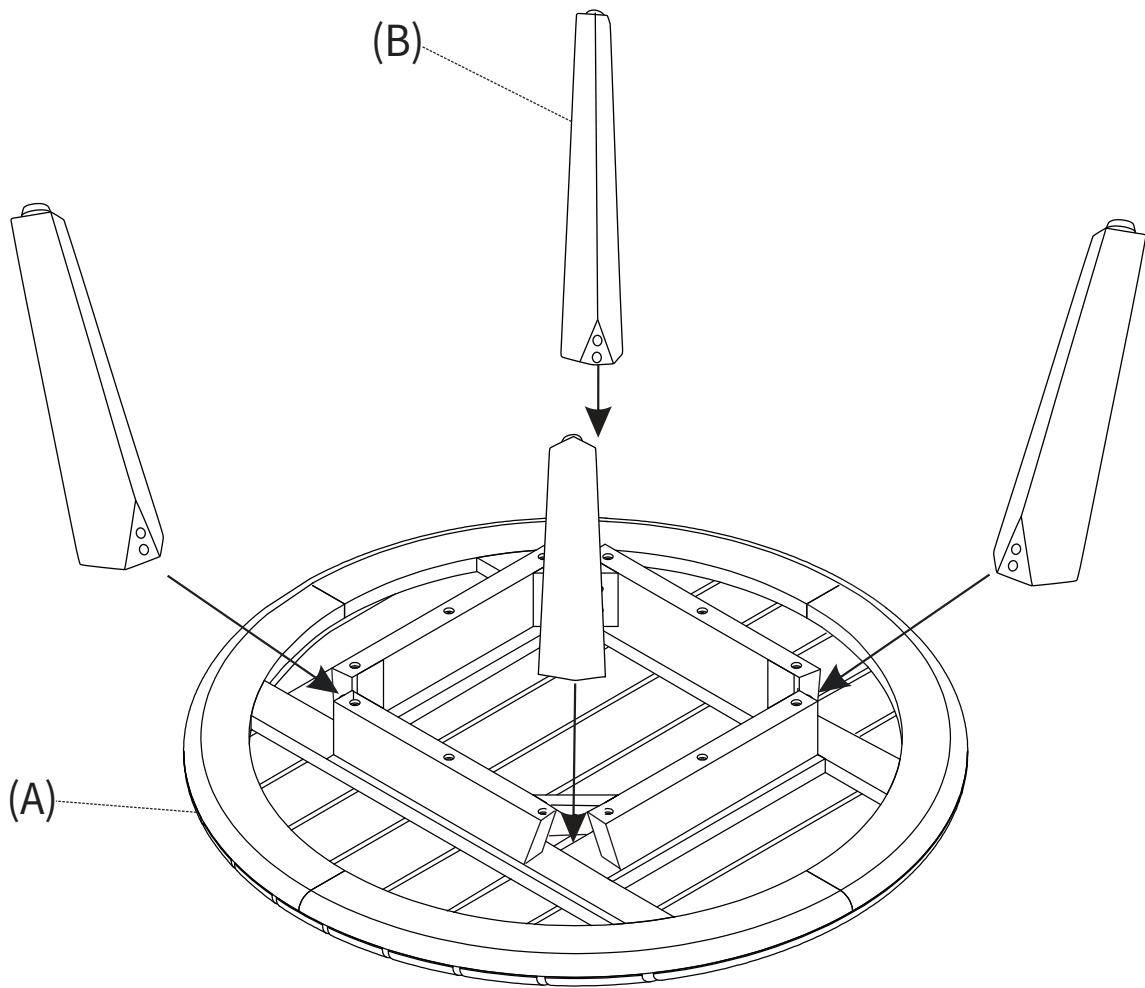

Turn Table top (A) upside down onto a clean, non-marring surface. Place Legs (B) in corresponding positions on bottom of Table top (A)

# Assembly Instructions

2

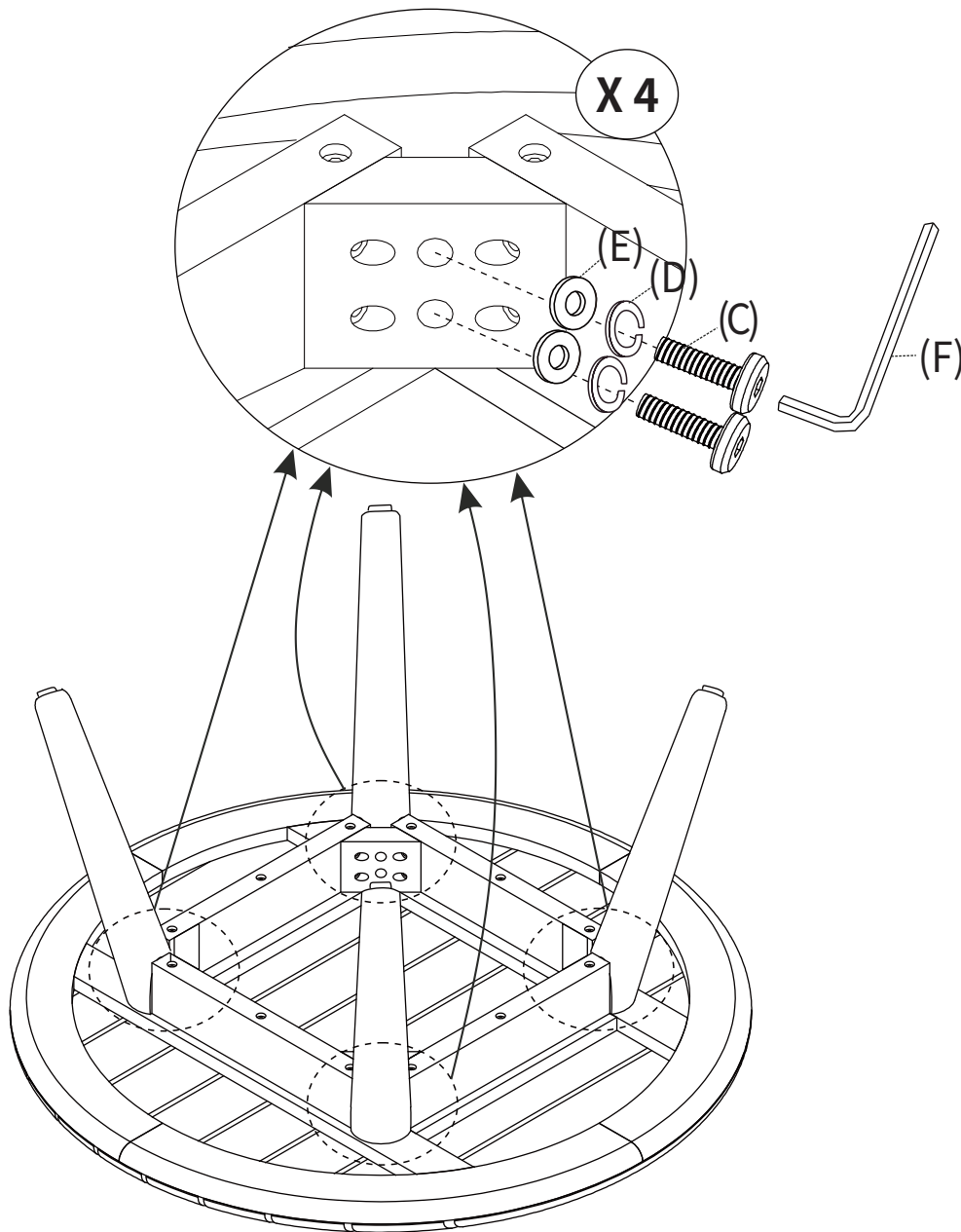

Secure with Bolt (C), Lock washers (D) and Flat washers (E) and stacking the hardware in the order as shown. Engage all of the bolts by hand, then tighten them using the Allen key (F). DO NOT over-tighten the bolts.

# Assembly Instructions

3

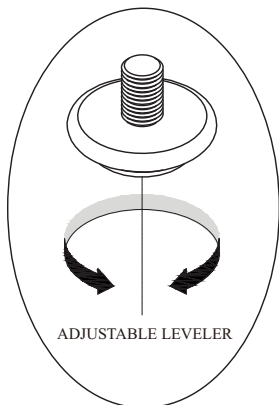
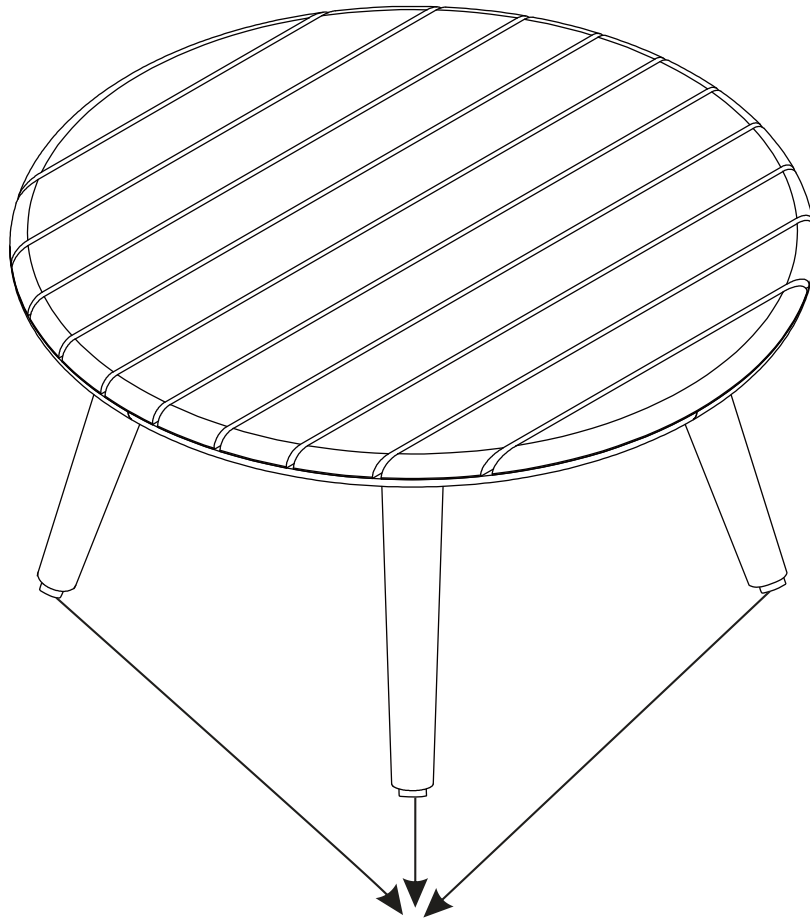

Levelers are located on the bottom of each leg and may be used for additional adjustment if needed for uneven surfaces