

# ASSEMBLY INSTRUCTION

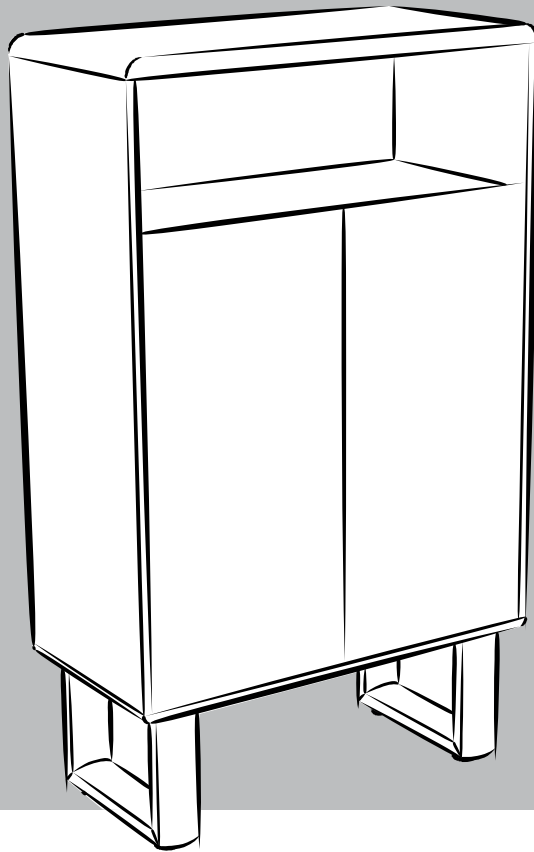

## **File Cabinet**

Assembly instructions and  
warranty information

The maximum recommended weight allowance is 30 lbs (13.6 kg) for top surface.  
The maximum recommended weight allowance is 30 lbs (13.6 kg) for shelf panel.

Item NV3100

## Installation of Cam Lock&Cam Bolt:

Screw the Cam Bolt into hole. To set Cam Lock correctly, ensure the arrow on the cam head points to the hole of the Cam Bolt it is locking. Lock Cam by turning cam head one third clockwise with screwdriver. Do not overtighten. Please don't use an Electric Screwdriver to assemble the unit.

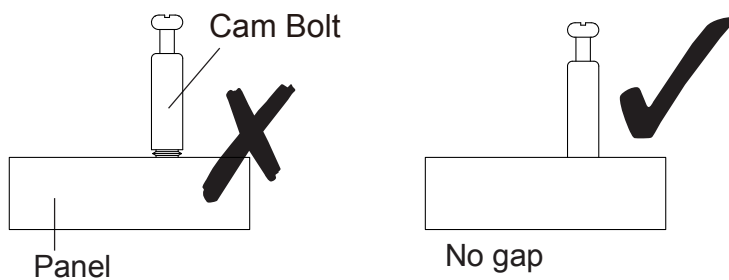
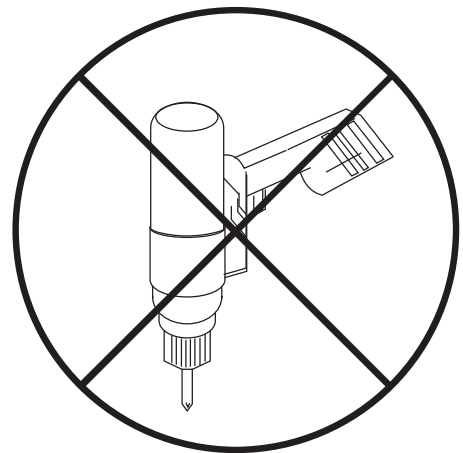
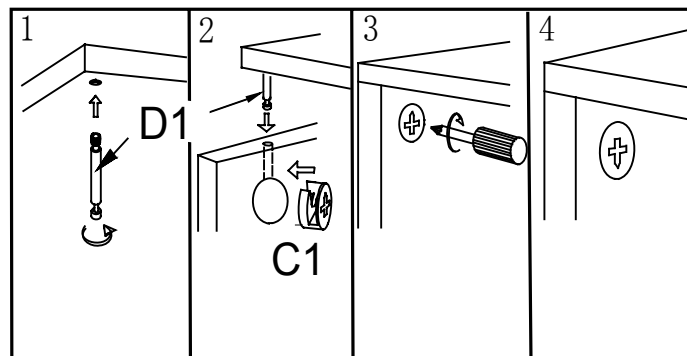



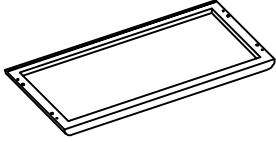
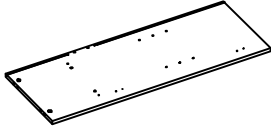
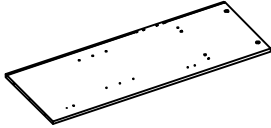
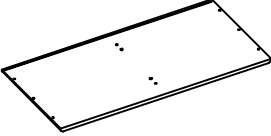
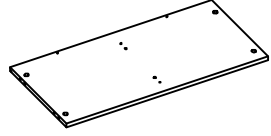
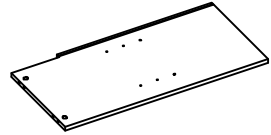
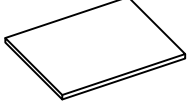

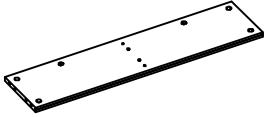
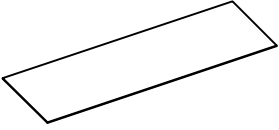
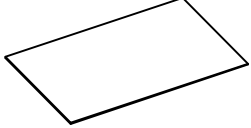
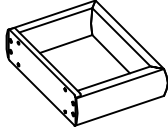
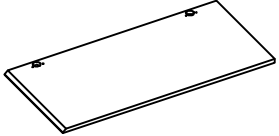
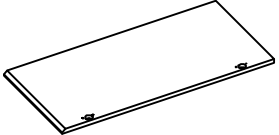



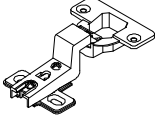
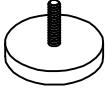

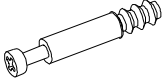

# PARTS LIST

Name	Part	Qty.
<b>A</b> Top panel		1
<b>B</b> Left Side Panel		1
<b>C</b> Right Side Panel		1
<b>D</b> Bottom Panel		1
<b>E</b> Fixed Shelf		1
<b>F</b> Divider		1
<b>G</b> Adjustable Shelf		2

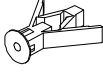



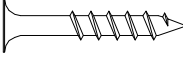
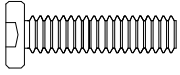

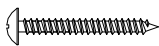

Name	Part	Qty.
<b>H</b> Back panel of Fixed Shelf		1
<b>I</b> Upper Back Panel		1
<b>J</b> Lower Back Panel		2
<b>K</b> Leg		2
<b>L</b> Left Door		1
<b>M</b> Right Door		1

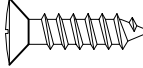
# PARTS LIST

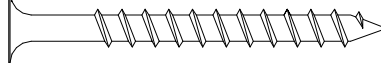
Name	Part	Qty.	Spare
A1 Hinge		4	
B1 Floor Leveler		4	
C1 Cam Lock		16	1
D1 Cam Bolt		16	1
E1 Plastic Cap		12	1
F1 Dowel		18	1
G1 Shelf Support		8	
H1 Allen Wrench		1	

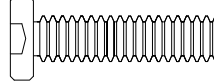
Name	Part	Qty.	Spare
I1 Wall Anchor		2	
J1 Connecting Plate		2	
L1 Glue		1	
S1 1/2" Screw		16	1
S2 2" Screw		10	1
S3 1" Bolt		8	1
S4 1/2" Screw		2	1
S5 1-1/2" Screw		2	1

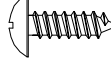
# COMPARISON SIZE CHART

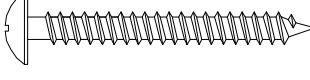
 S1	1/2" Screw	
 S2	2" Screw	
 S3	1" Bolt	
 S4	1/2" Screw	
 S5	1-1/2" Screw	

# STEP 1

D1



[ 4 ]

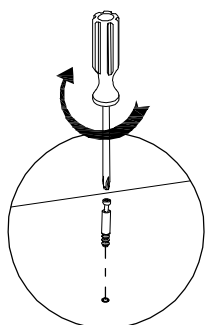
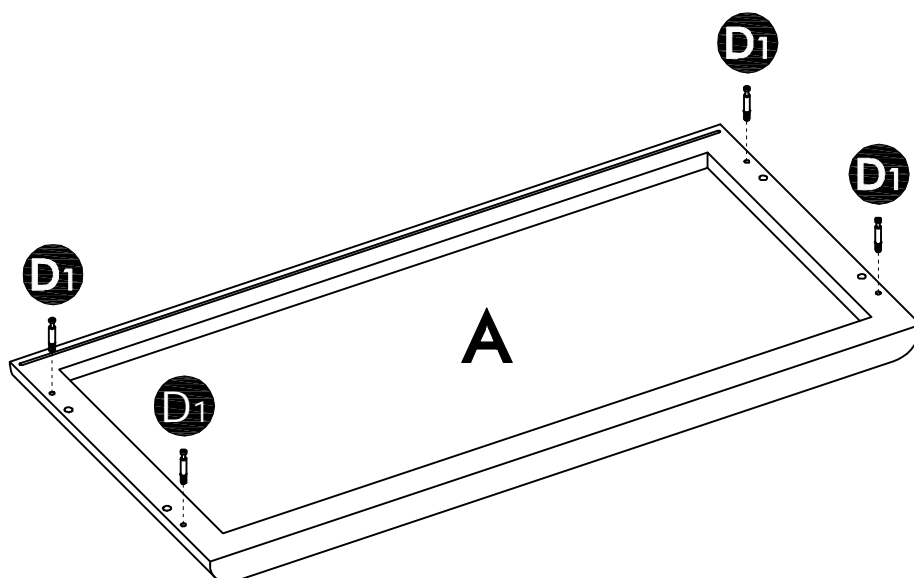
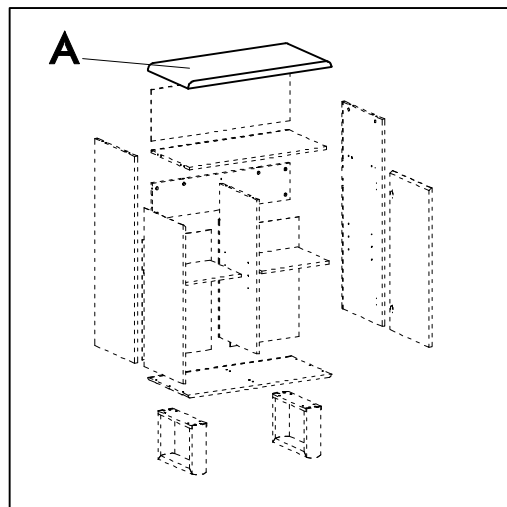

# STEP 2

**D1**  [ 8 ]

**F1**  [ 4 ]

**L1** 

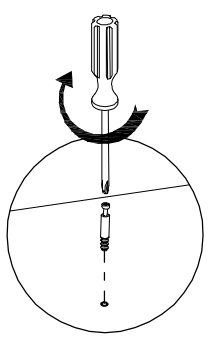
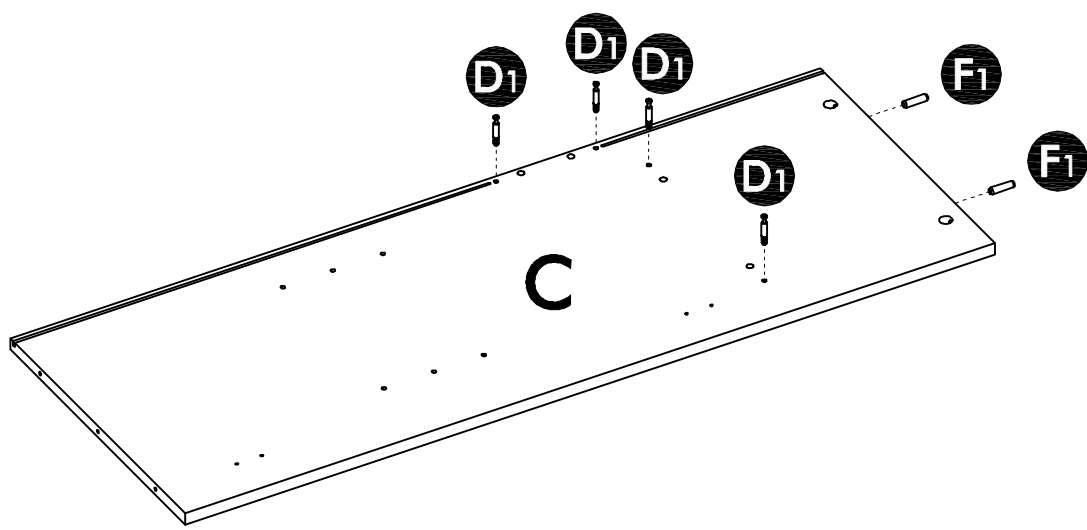
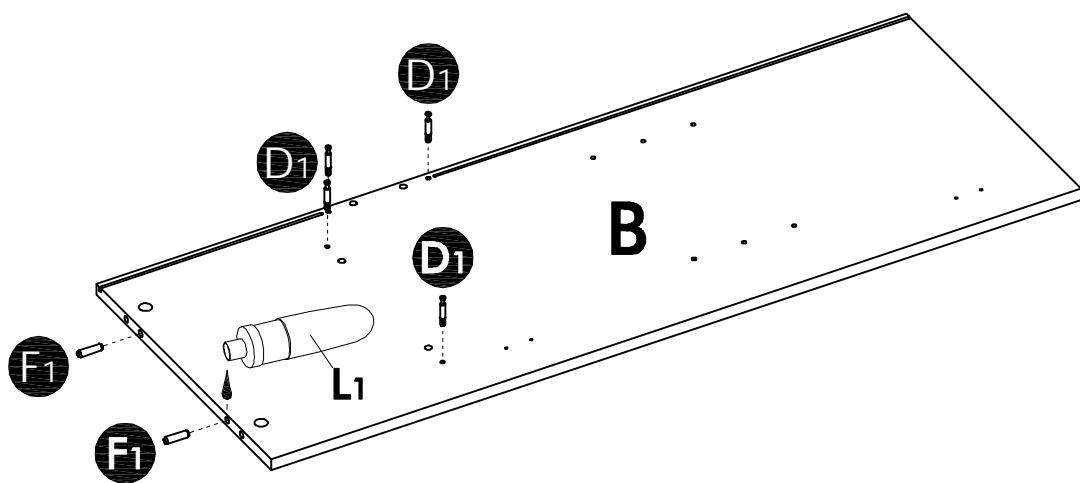
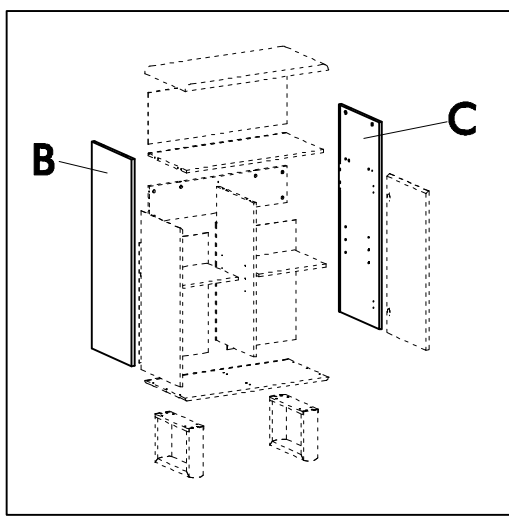

# STEP 3

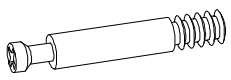
**D<sub>1</sub>**  [ 4 ]

**F<sub>1</sub>**  [ 10 ]

**L<sub>1</sub>** 

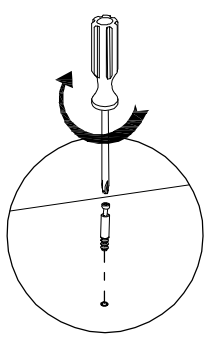
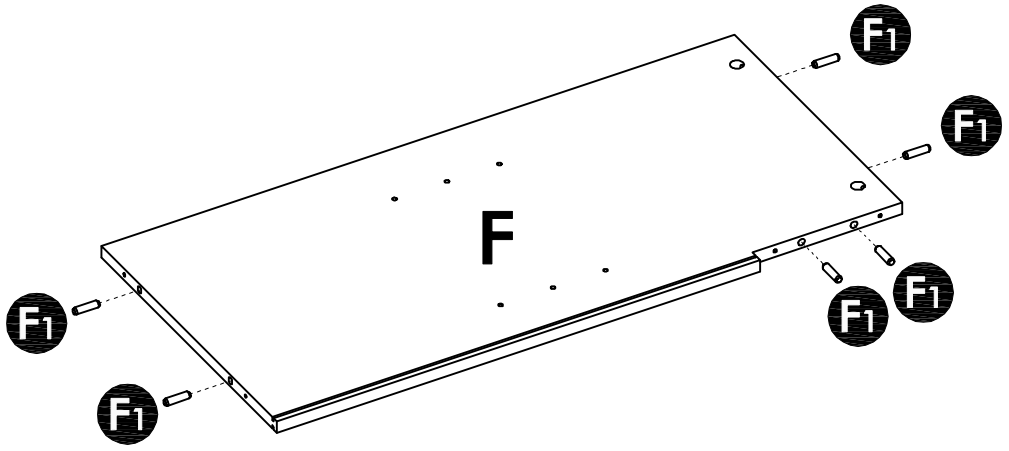
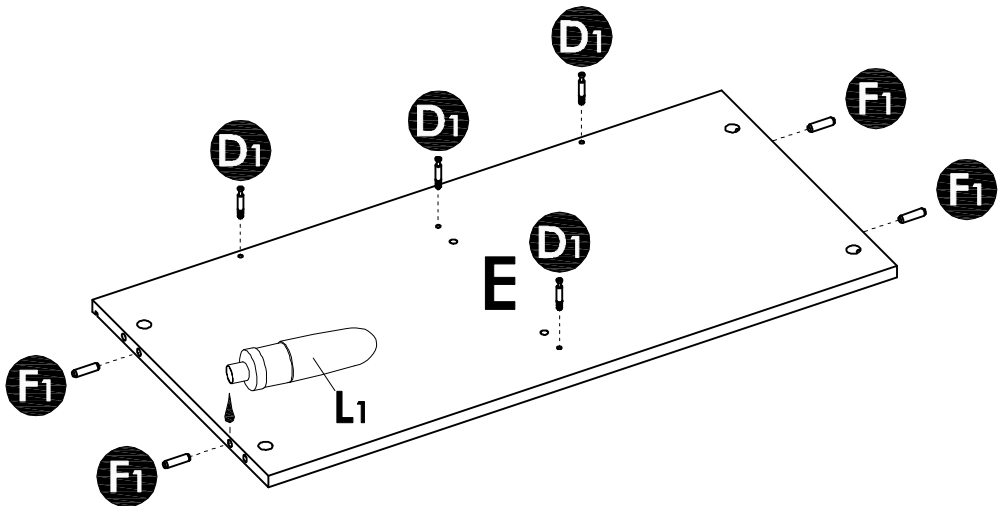
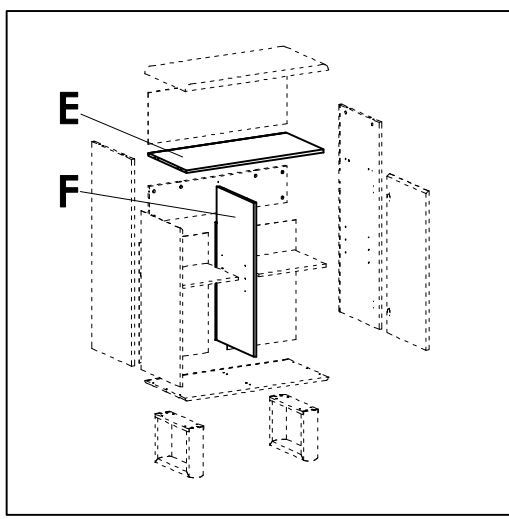

# STEP 4

**B<sub>1</sub>**  [ 4 ]

**F<sub>1</sub>**  [ 4 ]

**L<sub>1</sub>** 

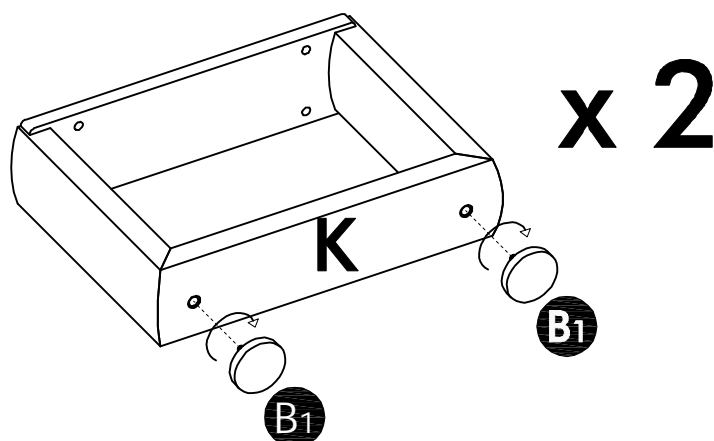
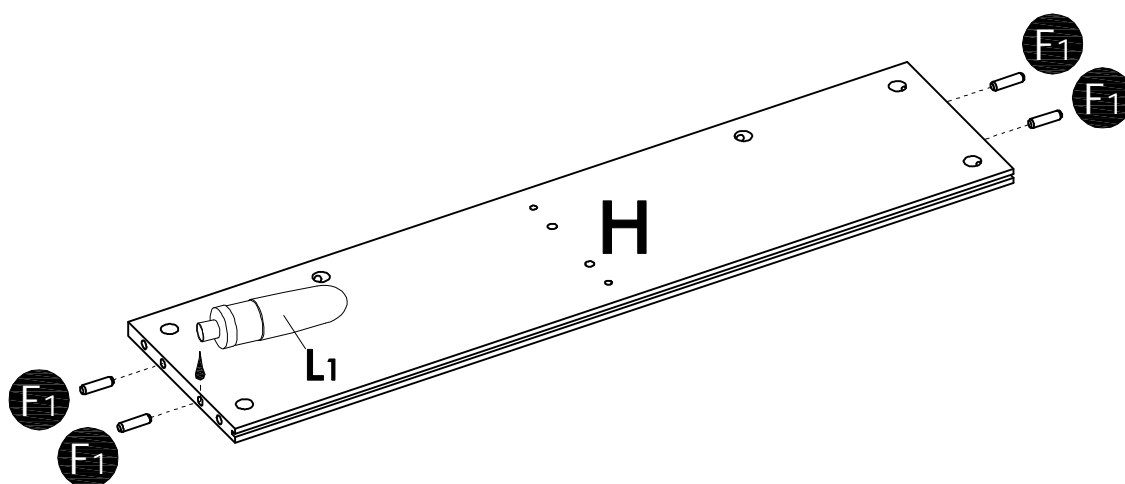
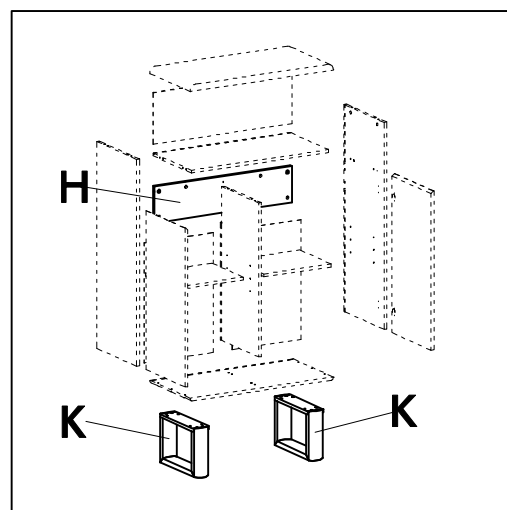

# STEP 5

A1

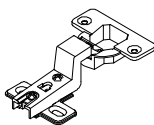

[ 4 ]

S1



[ 8 ]

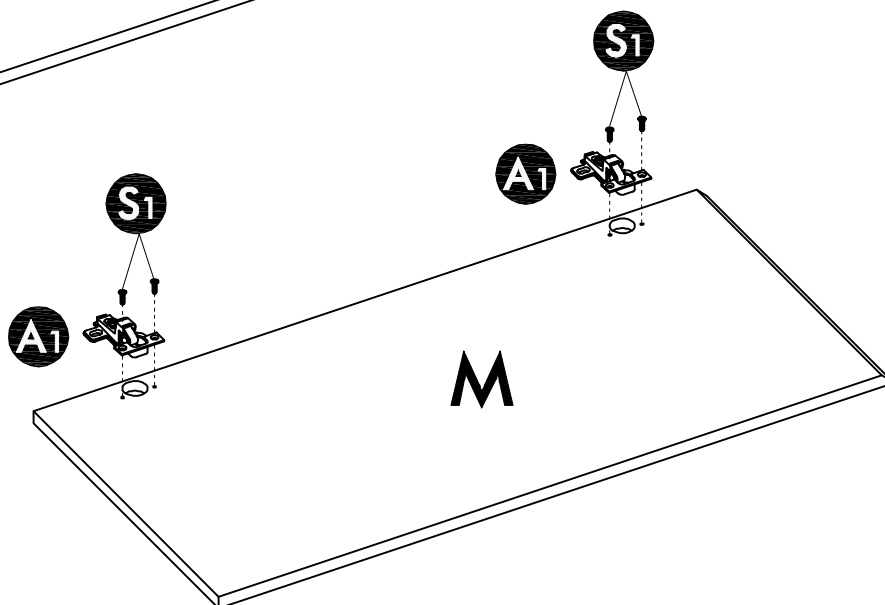
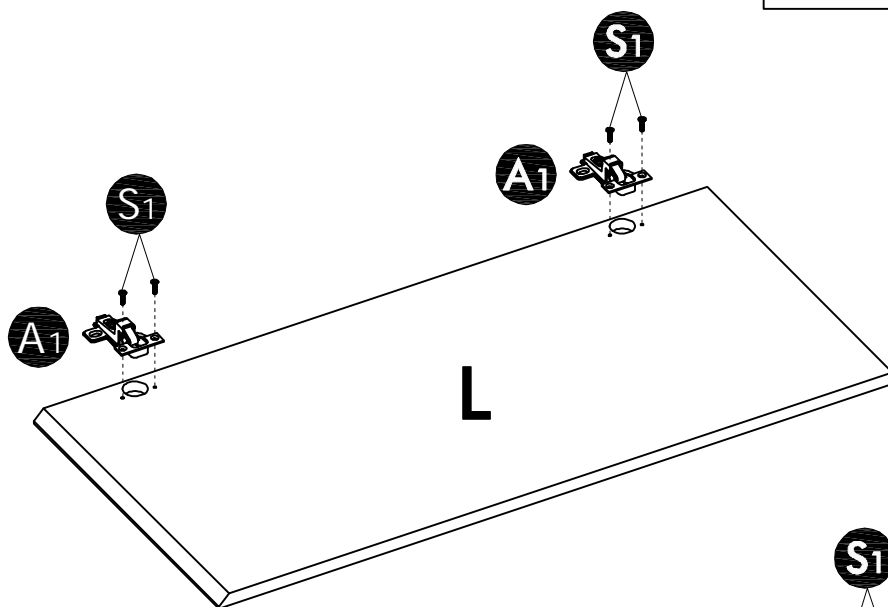
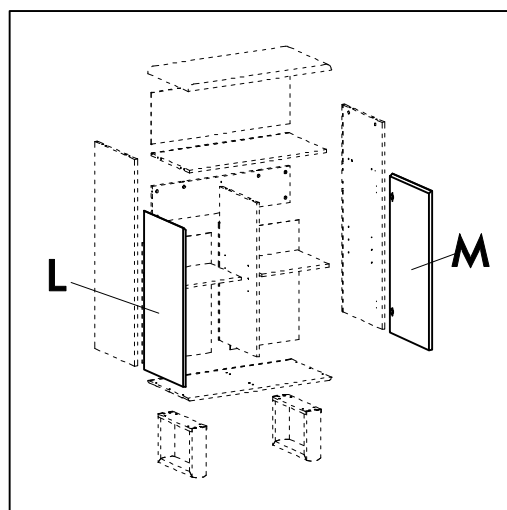

# STEP 6

S2

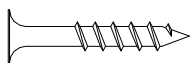

[ 2 ]

L1

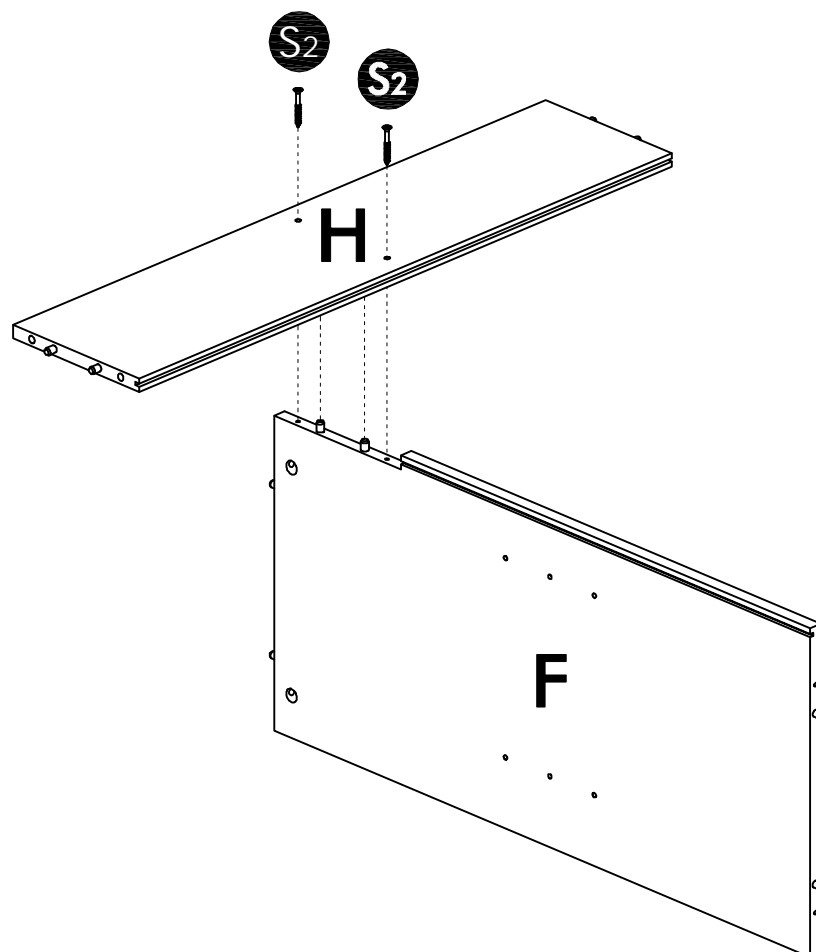
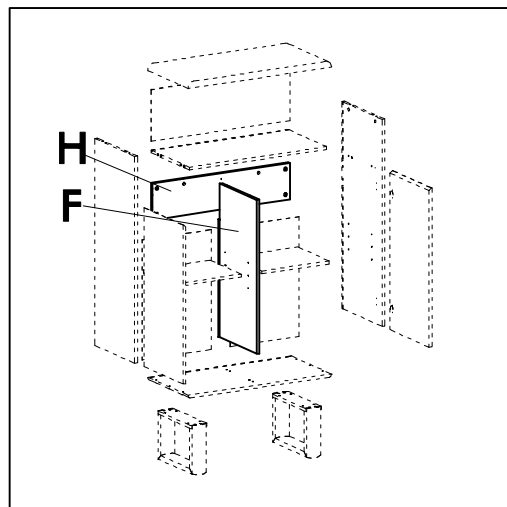

# STEP 7

C1



[ 4 ]

E1



[ 4 ]

L1

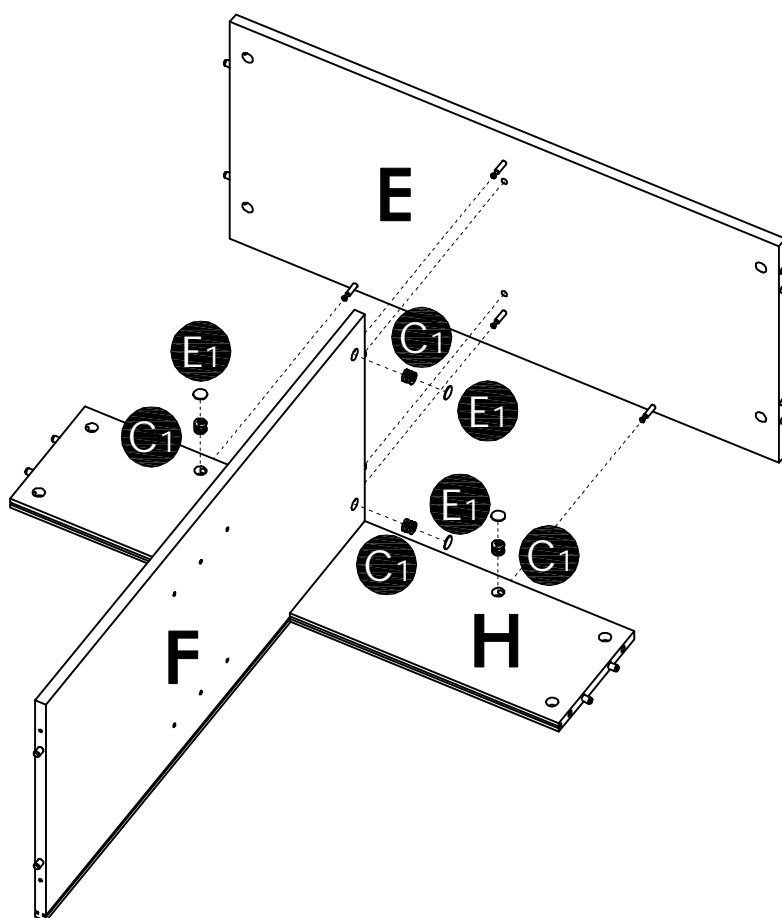
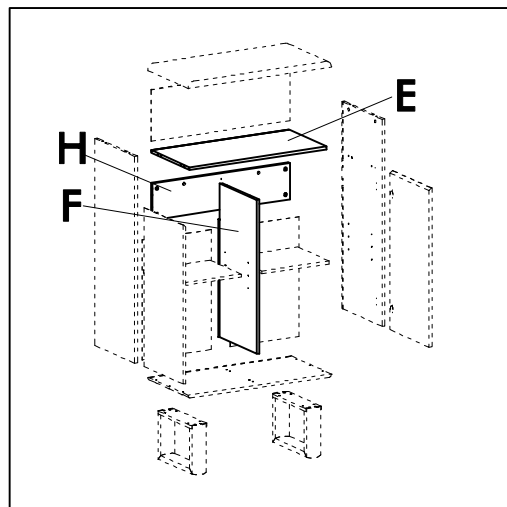

# STEP 8

C<sub>1</sub>



[ 8 ]

E<sub>1</sub>



[ 4 ]

L<sub>1</sub>

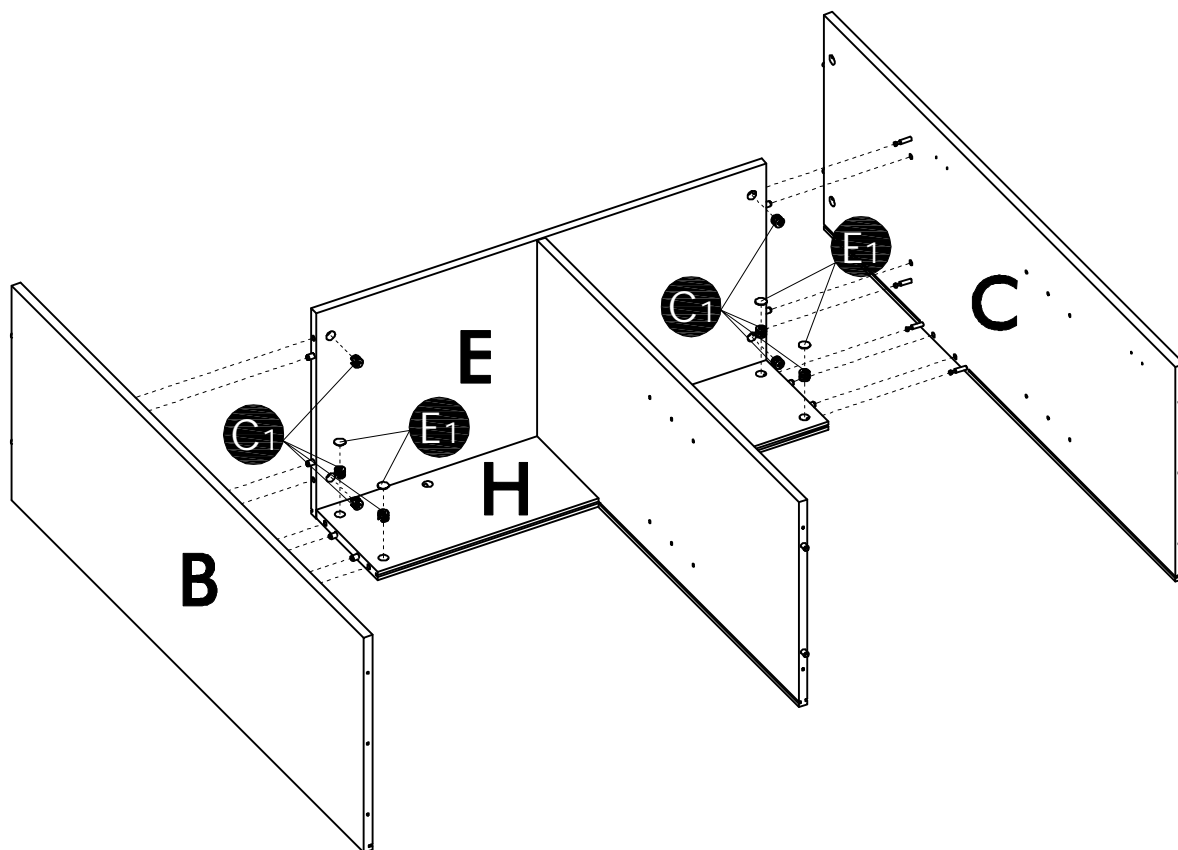
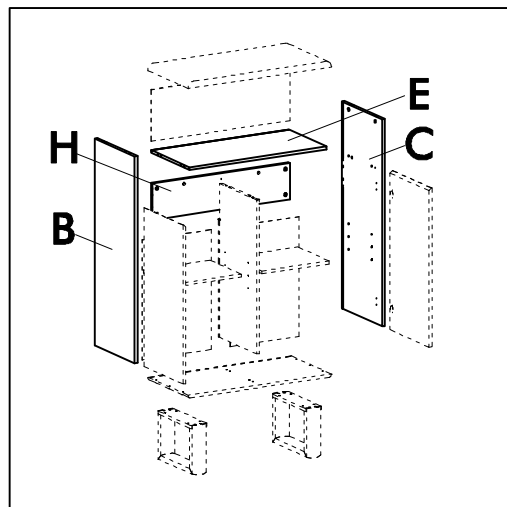

# STEP 9

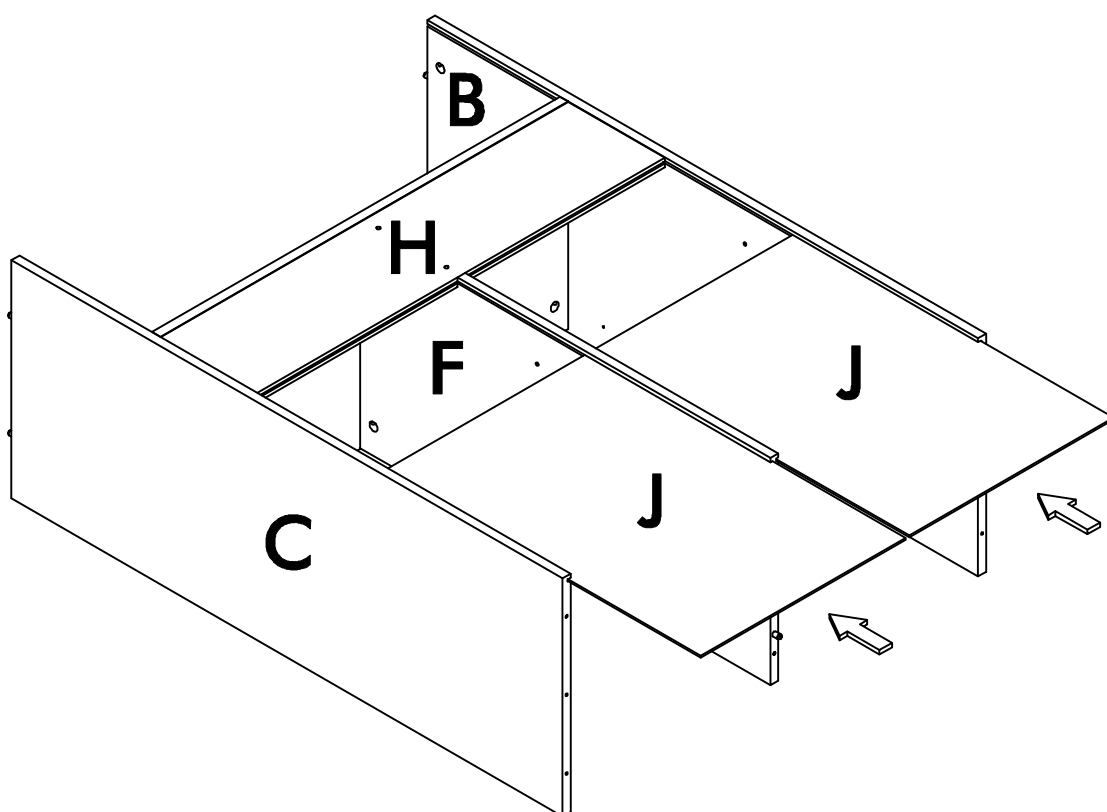
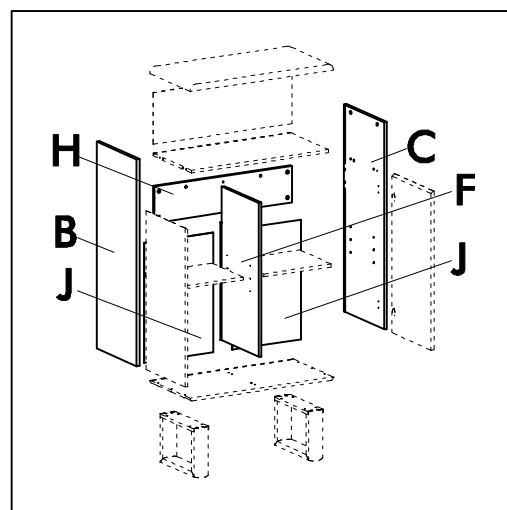



# STEP 11

S<sub>3</sub>

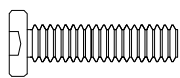

[ 8 ]

H<sub>1</sub>

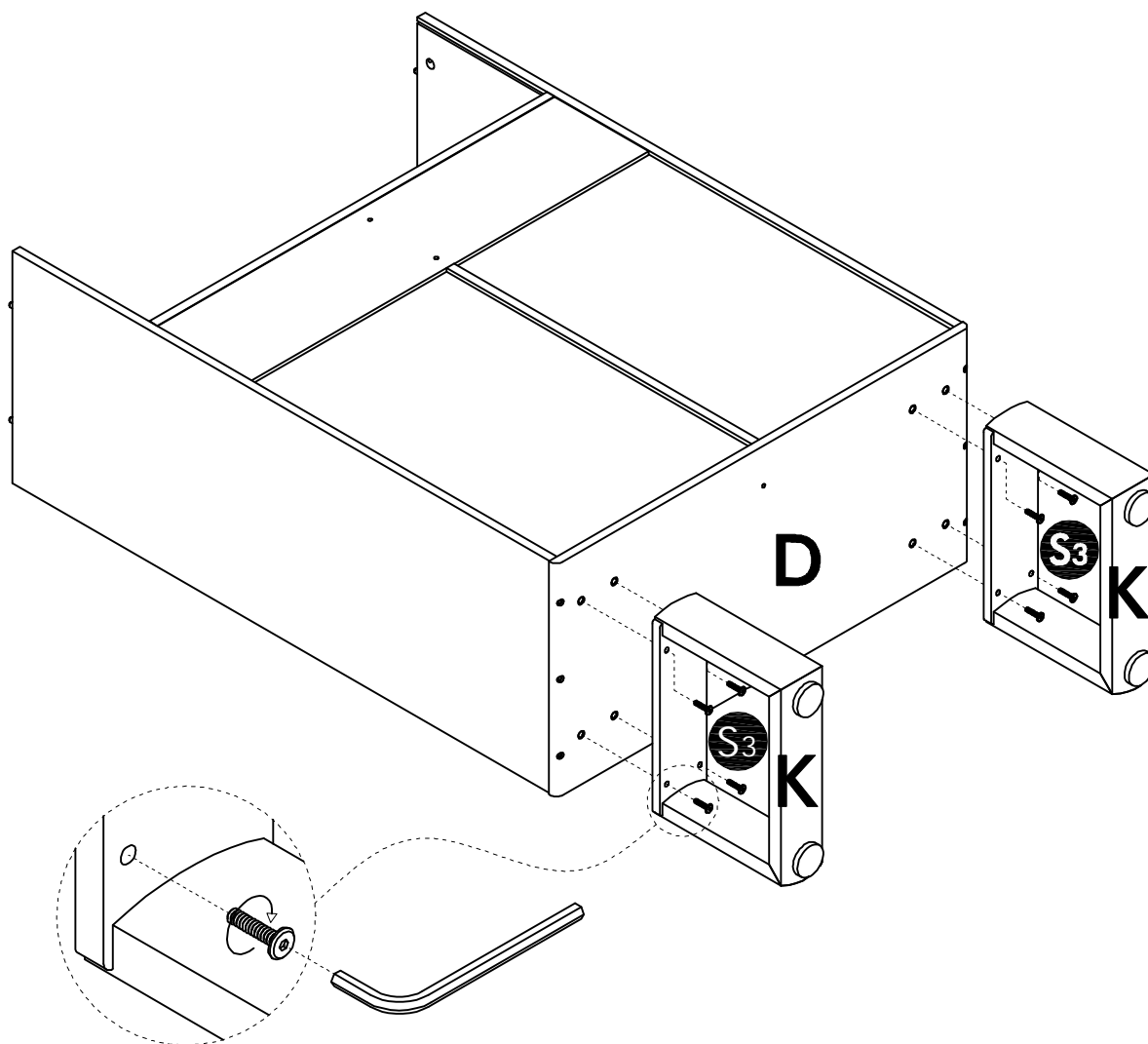
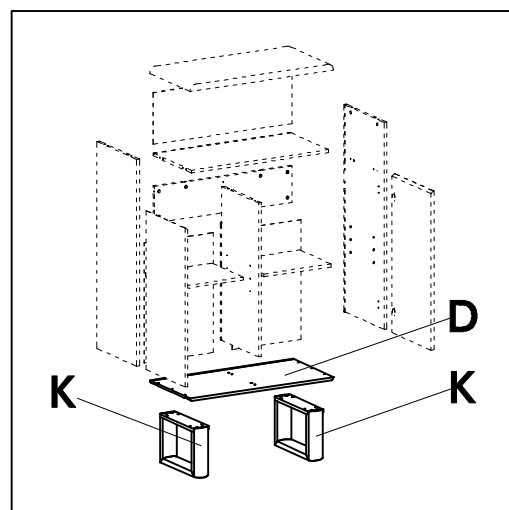

# STEP 12

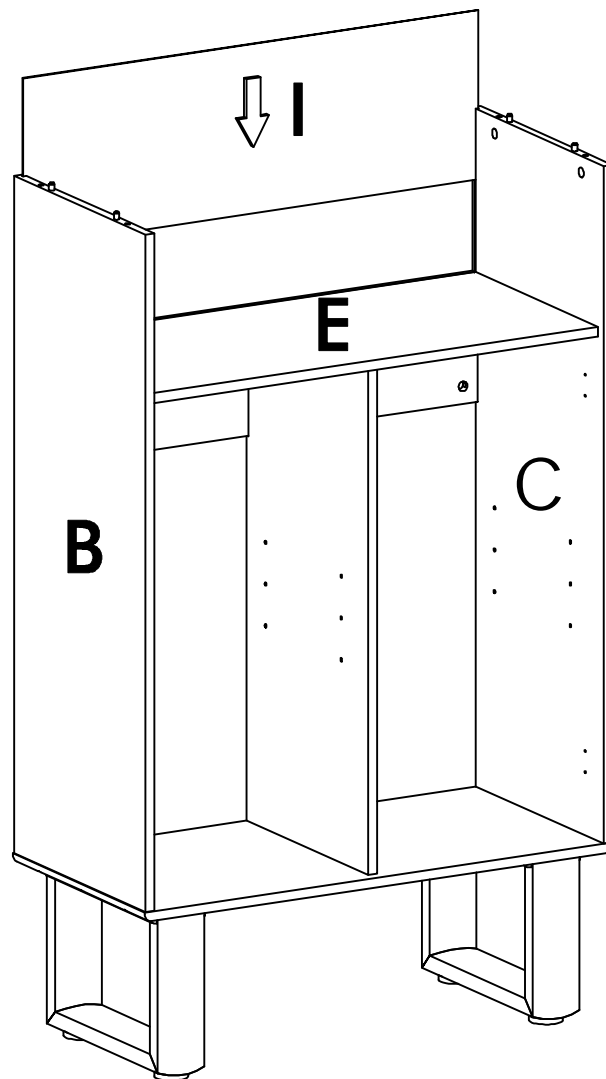
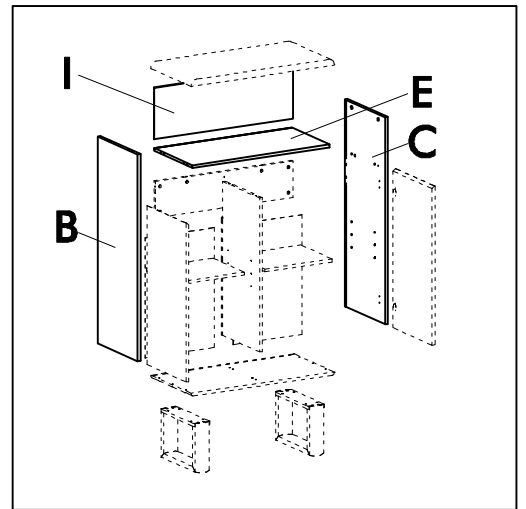

# STEP 13

**G<sub>1</sub>**



[ 4 ]

**E<sub>1</sub>**



[ 4 ]

**L<sub>1</sub>**

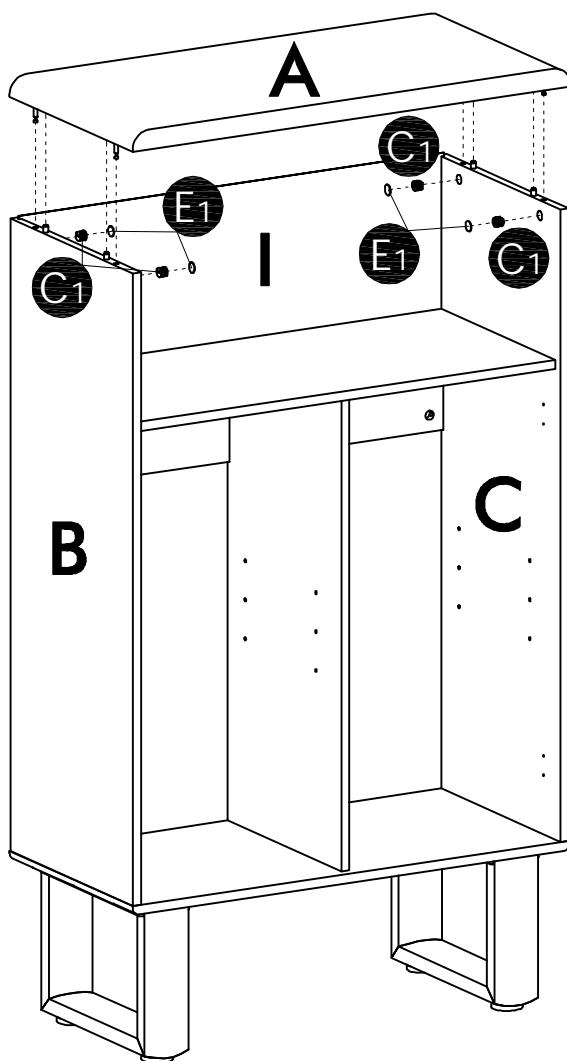
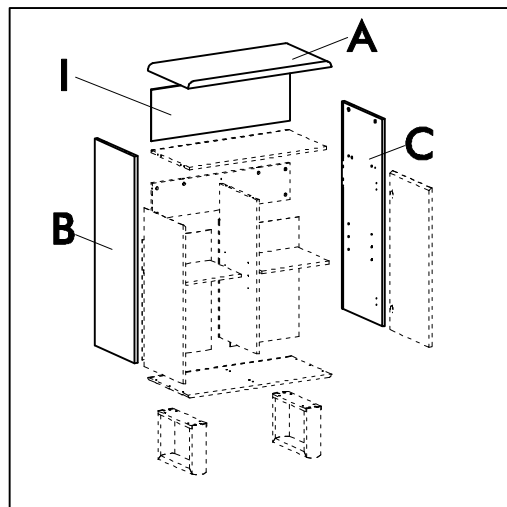

# STEP 14

G1



[ 8 ]

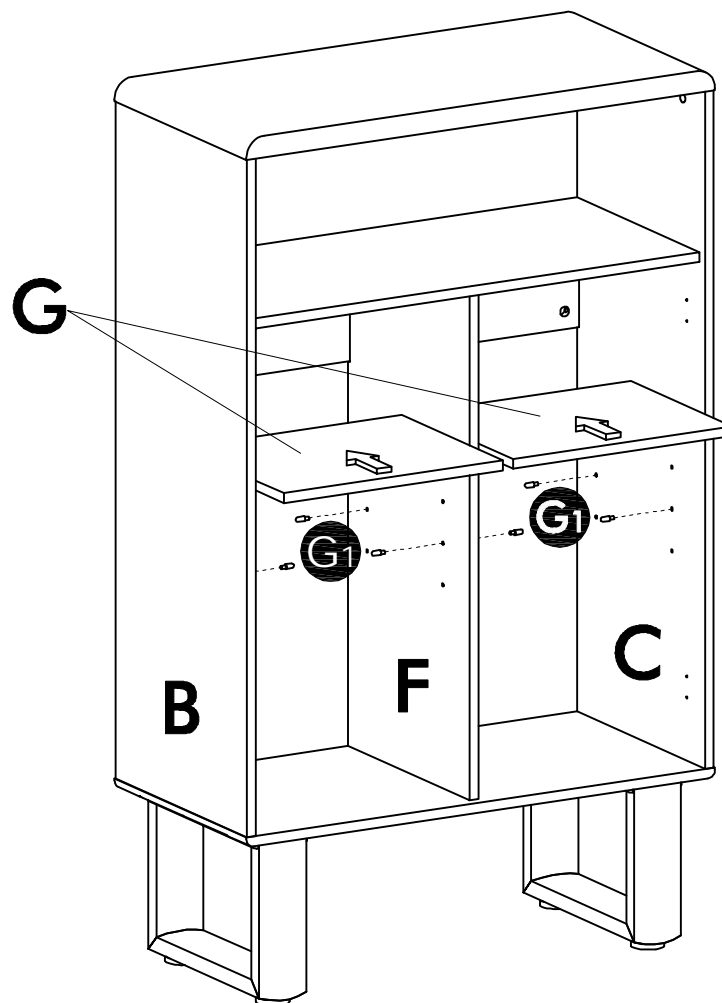
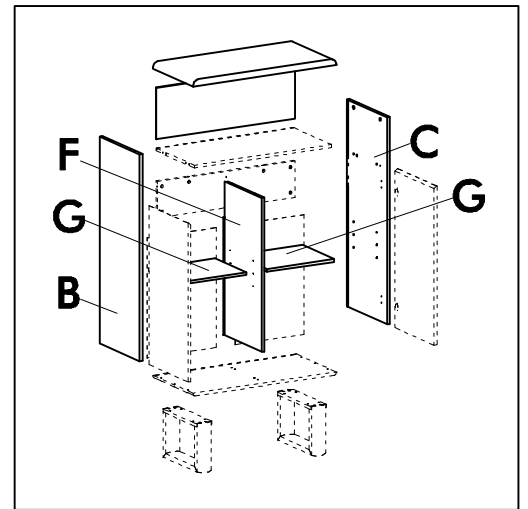

# STEP 15

S1



[ 8 ]

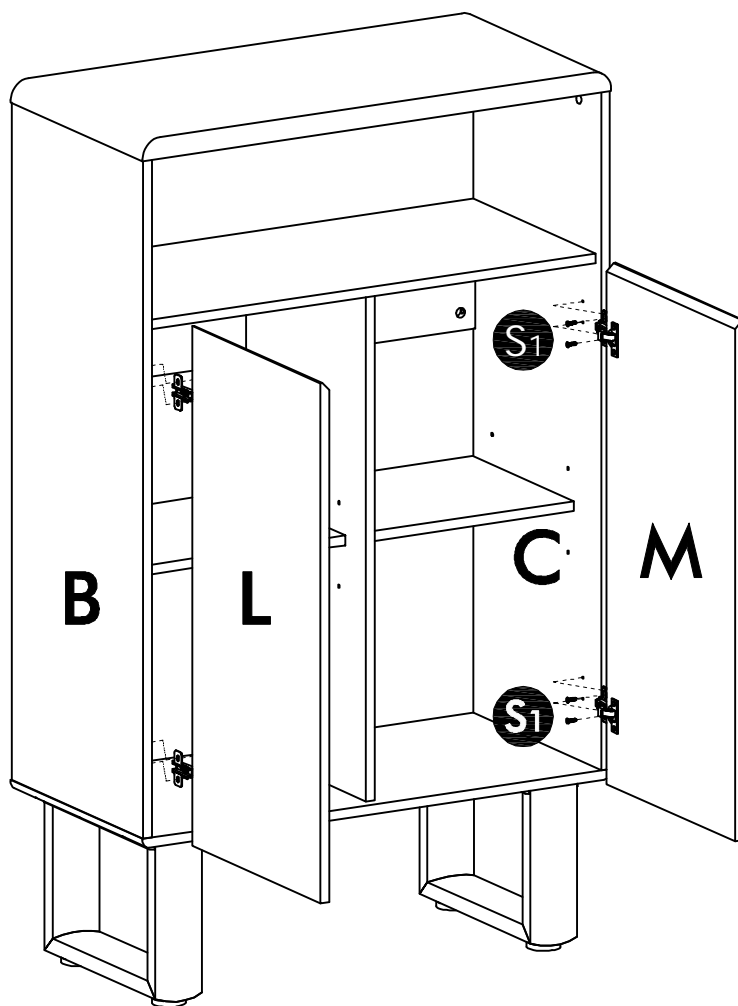
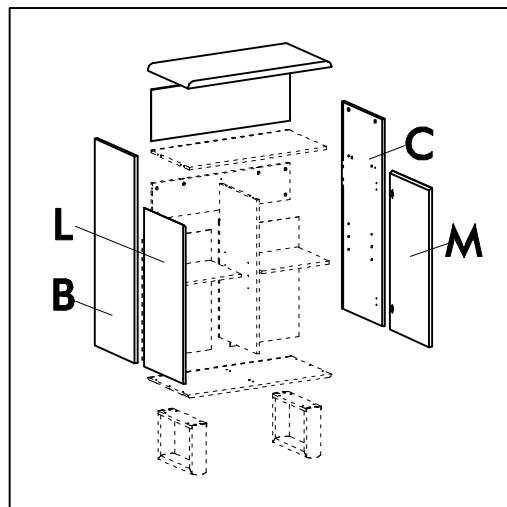
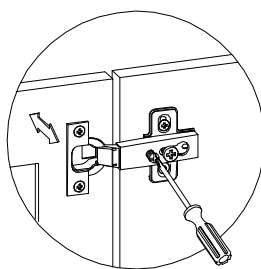
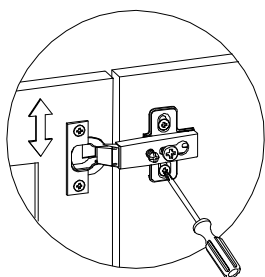
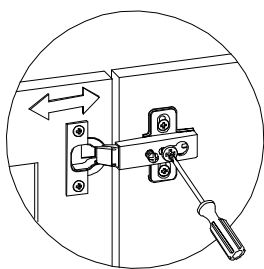

# STEP 16

J1

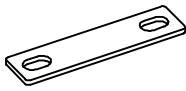

[ 2 ]

S4



[ 2 ]

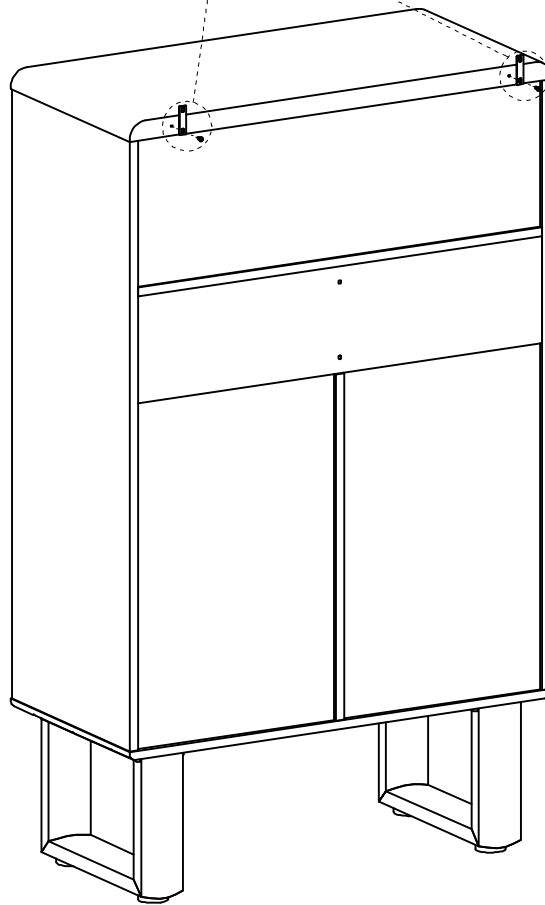
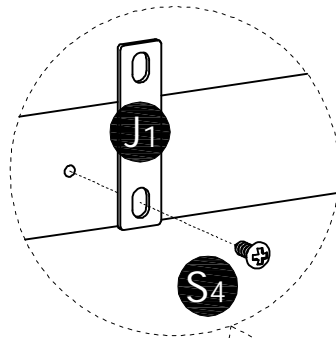
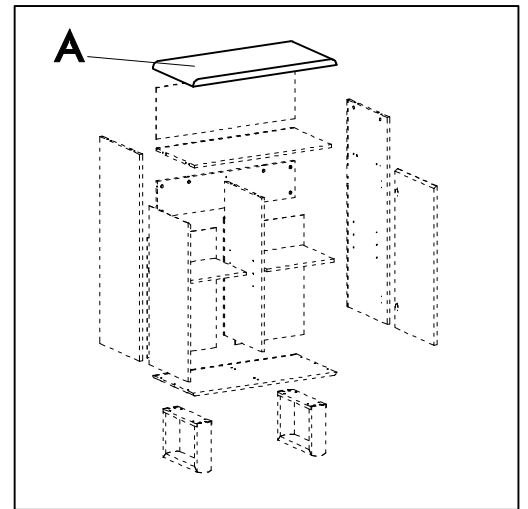

# STEP 17

I1

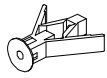

[ 2 ]

S5

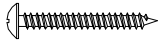

[ 2 ]

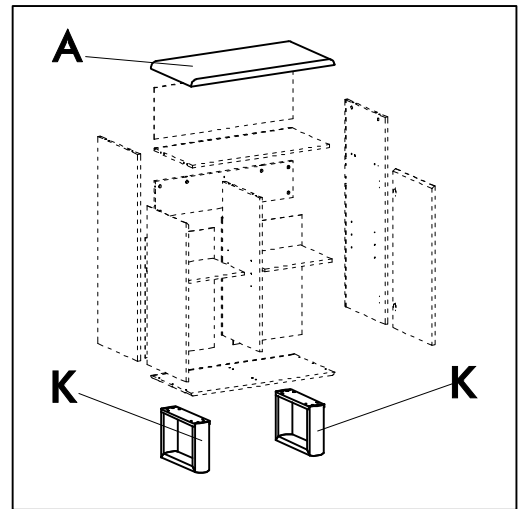

1  
Draw a dot on the wall

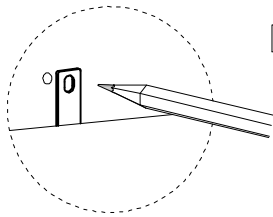

2  
Make a hole on the wall

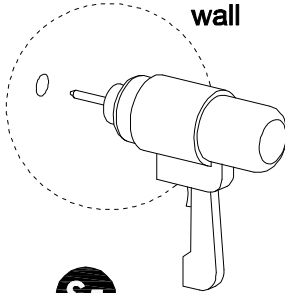

3

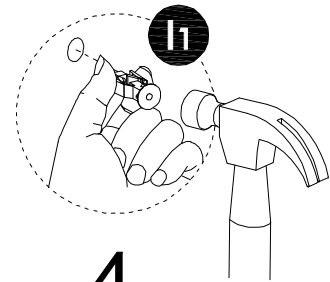

4

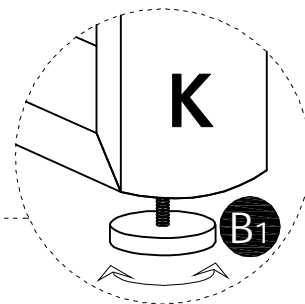
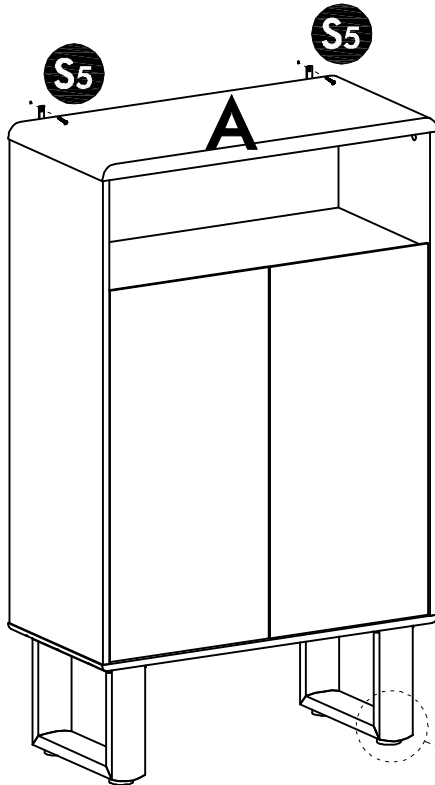
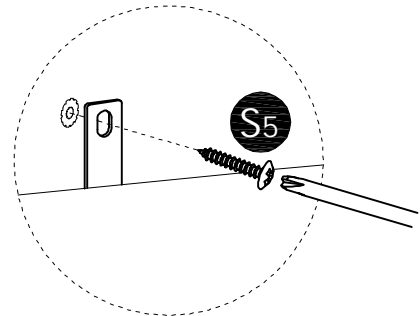

## Huali Trading Australia Pty Ltd Limited Three Year Warranty

This limited warranty covers the original purchase of new products used for normal commercial, personal or household use. Huali Trading Australia Pty Ltd (HTA) warrants its products will be free from defects in materials and workmanship (normal wear and tear excepted), for three (3) years from the date of purchase, except as provided below. Any defective part for this product must be reported to HAT by the purchaser within 30 days of when defect becomes known. HAT, at its' option, will repair or replace this product or component(s) free of charge. Original sales receipt will be required prior to repair or replacement. This warranty applies under conditions of normal use. This warranty does not apply to damage caused by fire, accident, negligence, misuse, use other than as stated in product instructions, improper cleaning or other circumstances not directly attributable to defects in materials and workmanship.

The word defects in this warranty is defined as imperfections that impair the use of the furniture product.

Natural variations occurring in wood or other materials will not be considered defects, and HTA does not warrant the colour – fastness or matching of colours, grains, or textures of such materials. This Warranty does not apply to: modifications of the product, attachments to the product not approved by HTA, and products that were not installed, used, or maintained in accordance with product instructions and warnings.

This warranty has the following exceptions: Fabrics, foam, veneer finishes and other covering materials are warranted for two (2) years from date of purchase.

Proof of purchase is required in the form of a receipt (copy or original) to validate warranty. All warranty claims can either be sent to:

Huali Trading Australia Pty Ltd  
PO BOX 516  
Wentworthville NSW 2145

Or faxed to (02) 9621 1050

HTA's sole obligation and the users exclusive remedy under this warranty shall be limited to the repair, Credit (only applies to distributors) or replacement at HTA's sole discretion and cost, of product or components under the "COMPETITION AND CONSUMER ACT 2010".

*"Our goods come with guarantees that cannot be excluded under the Australian Consumer Law. You are entitled to a replacement or refund for a major failure and for compensation for any other reasonably foreseeable loss or damage. You are also entitled to have the goods repaired or replaced if the goods fail to be of acceptable quality and the failure does not amount to a major failure".*

### Service Instructions

If you are having trouble with assembling your new furniture, please call us on (02) 9621 4428 for assistance.