

# Assembly Instructions

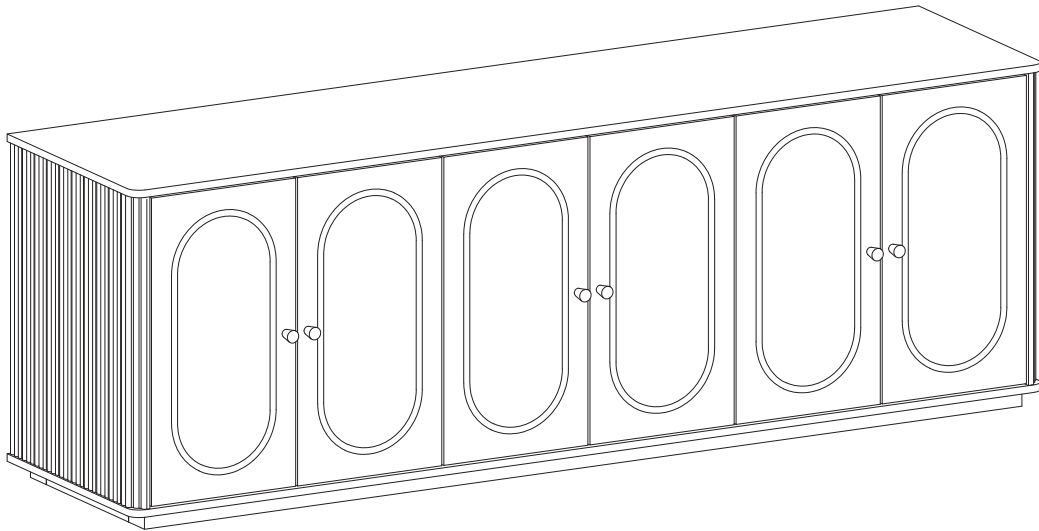

# Before Assembly

## Tips Before Your Start:

Remove all wrapping material, including staples & packing straps before you start to assemble.

DO NOT tighten all screws and bolts until the assembly is completely assembled.

- Keep all hardware parts out of reach of children.

### QUICKFIT

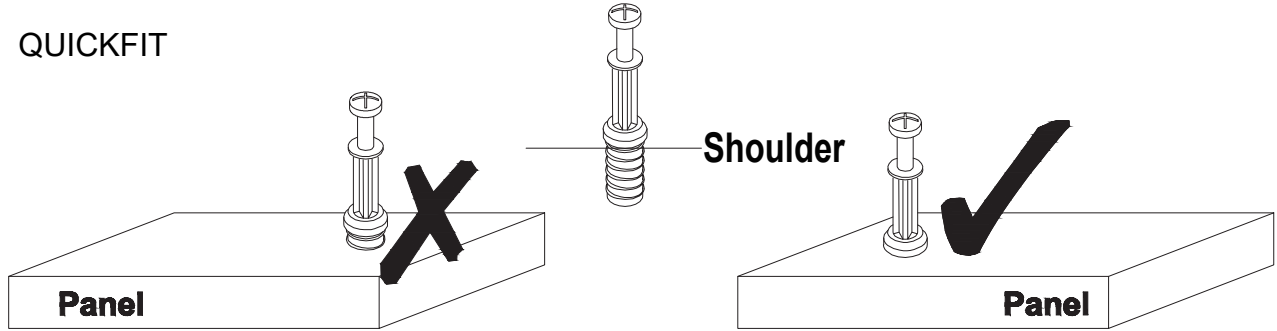

Tighten quickfit until shoulder is flush with panel. Do not overtighten or undertighten.

### CAM LOCK

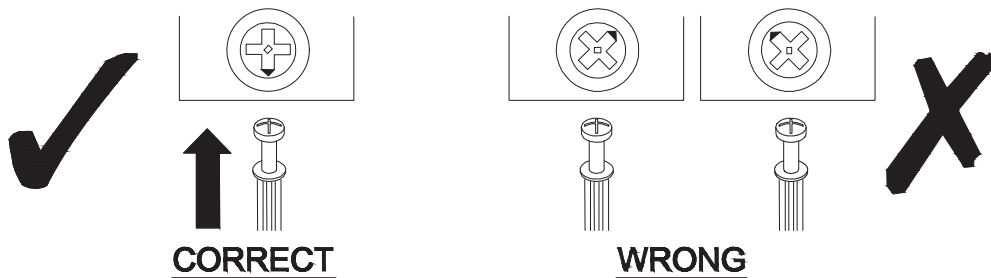

When fitting a cam lock, ensure the starting position is correct before inserting the connecting QUICKFIT

Quickfit head should be in the centre of the cam lock when the two panels are joined.

Cam lock should be inserted before quickfit.

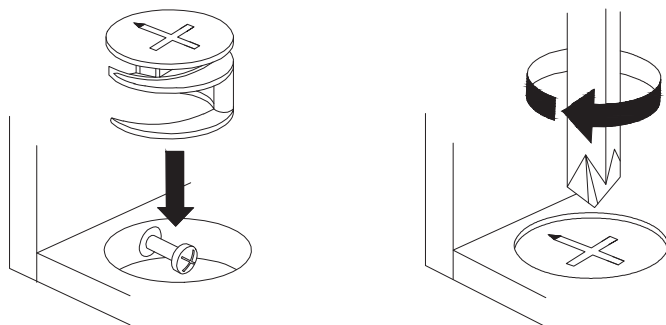

Turn cam lock clockwise to tighten.

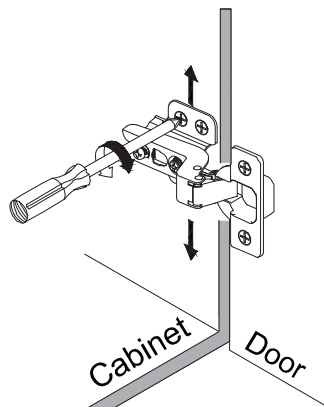
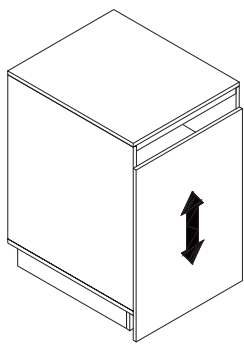
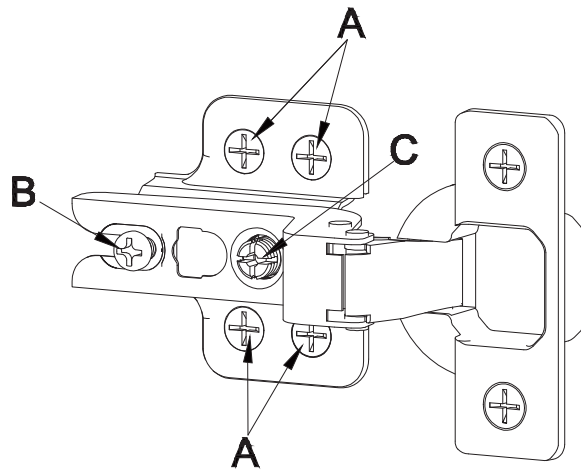

**To adjust the vertical height.**

Loosen the four screws "A" on both hinges. Two of them are usually in slotted holes which allows you to adjust up or down by a few mm. Then tighten back up.

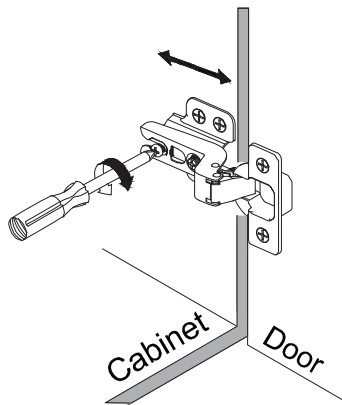
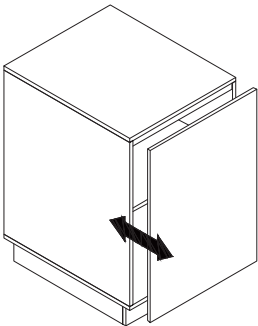

**To adjust depth.**



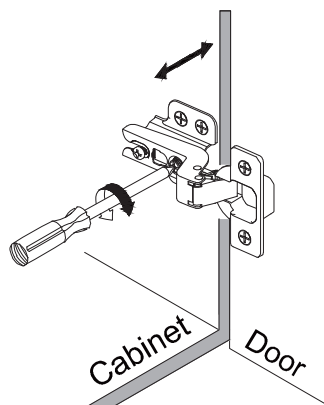
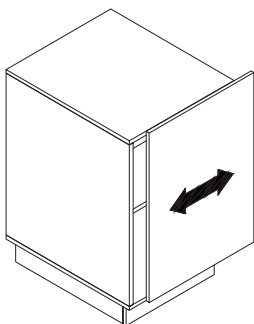



Loosen screw "B" and adjust door, if the door can not be adjusted, please loosen screw "C", then try again. Tighten screw "B" and "C".

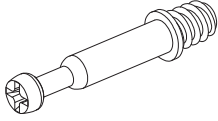

**To adjust side ways.**

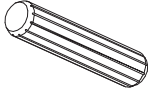
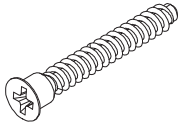
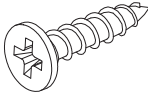
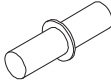
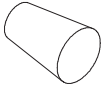
Turning the screw "C" on BOTH hinges on each door.

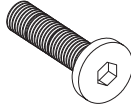
# Part List

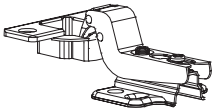
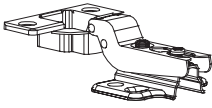
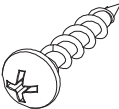
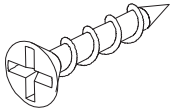
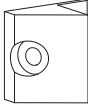
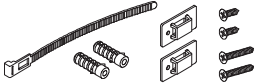
<p><b>No. A</b> Quantity: 8+1 PCS Cam Bolt ø6x33.5mm</p> 	<p><b>No. B</b> Quantity: 8+1 PCS Cam ø15x9.5mm</p> 	<p><b>No. C</b> Quantity: 8+1 PCS Sticker ø20mm</p> 	<p><b>No. D</b> Quantity: 16+2 PCS Dowel ø6x30mm</p> 
<p><b>No. E</b> Quantity: 8+1 PCS Screw ø5x48mm</p> 	<p><b>No. F</b> Quantity: 72+2 PCS Screw ø3.5x14mm</p> 	<p><b>No. G</b> Quantity: 12+1 PCS Screw ø5x16mm</p> 	<p><b>No. H</b> Quantity: 6 PCS Handle ø20x23mm</p> 
<p><b>No. I</b> Quantity: 6 +1 PCS Screw M4x16mm</p> 	<p><b>No. J</b> Quantity: 16 PCS Bolt M6x25mm</p> 	<p><b>No. K</b> Quantity: 2 PCS Bolt M6x12mm</p> 	<p><b>No. L</b> Quantity: 1 PCS Hex Key 4mm</p> 
<p><b>No. M</b> Quantity: 4 PCS Hinge ø35mm</p> 	<p><b>No. N</b> Quantity: 8 PCS Hinge ø35mm</p> 	<p><b>No. P</b> Quantity: 8+1 PCS Screw ø4x12mm</p> 	<p><b>No. R</b> Quantity: 10 PCS Screw ø3x16mm</p> 
<p><b>No. S</b> Quantity: 10 PCS Back Buckle 15x15x10mm</p> 	<p><b>No. T</b> Quantity: 1 Set</p> 		

**SAFETY TIPS:** Static charge may cause dust on foam - clean with a dry or damp cloth. Small foam strands may be present - handle gently and dispose of properly. Do not bur or incinerate. Check local recycling guidelines.

# Product structure

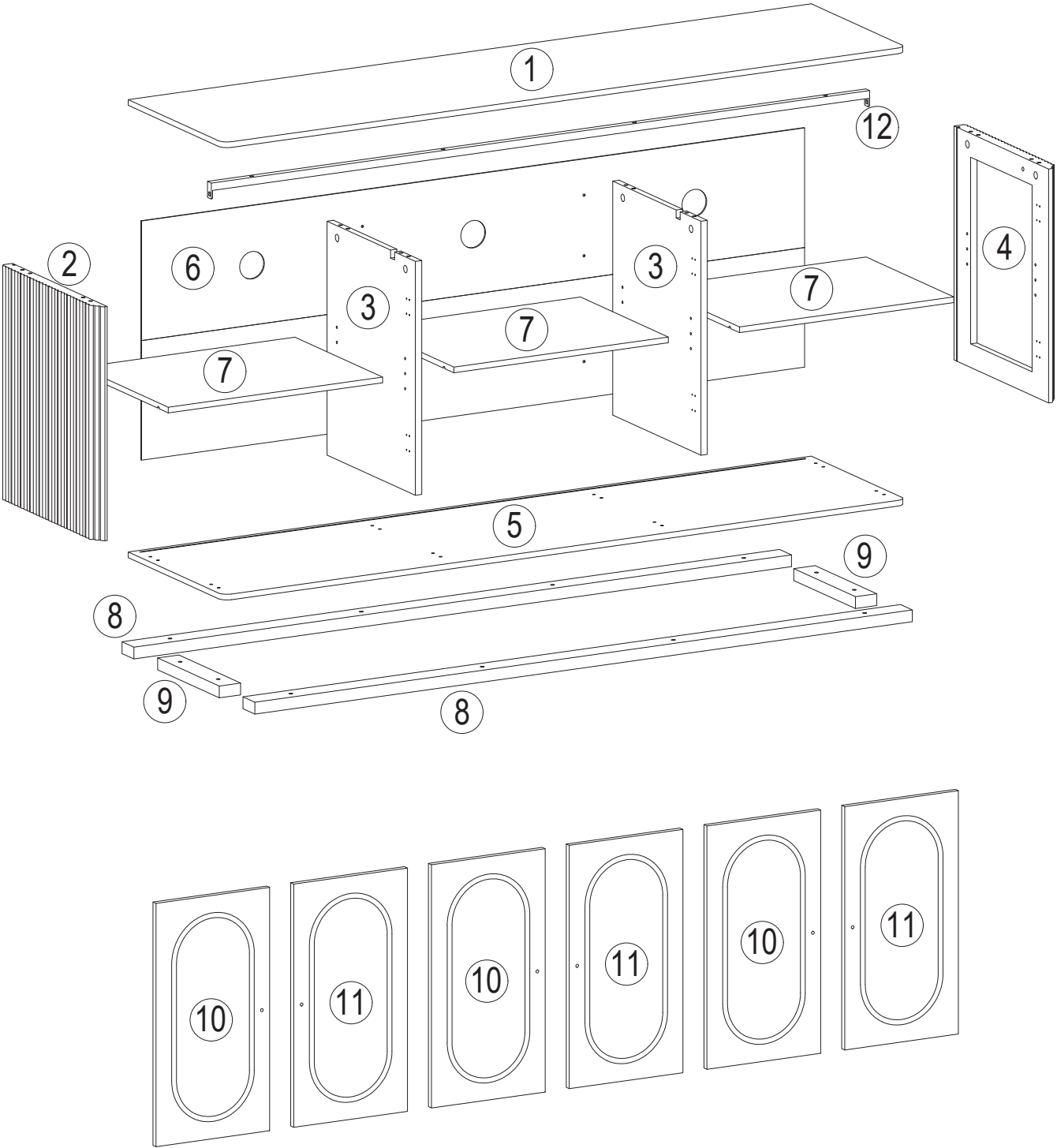

# STEP 1

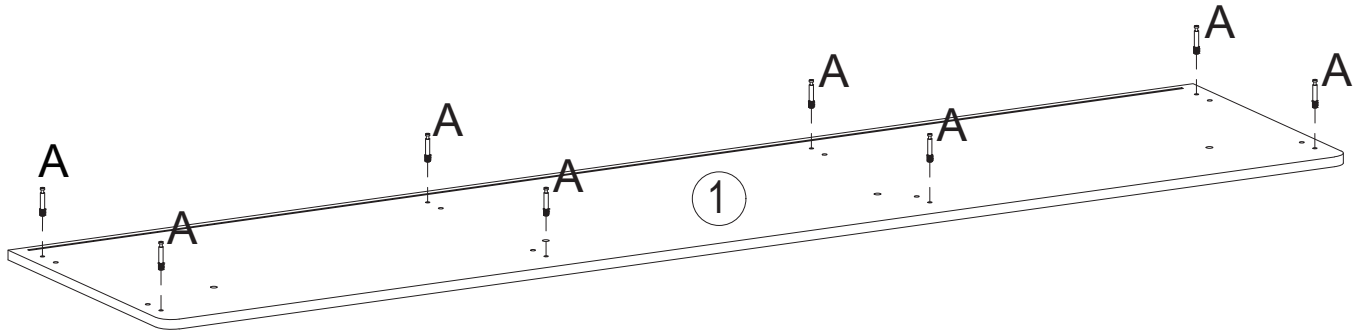

Tighten All bolt #J to 80% first.  
After completing Step3,  
tighten All bolt completely.

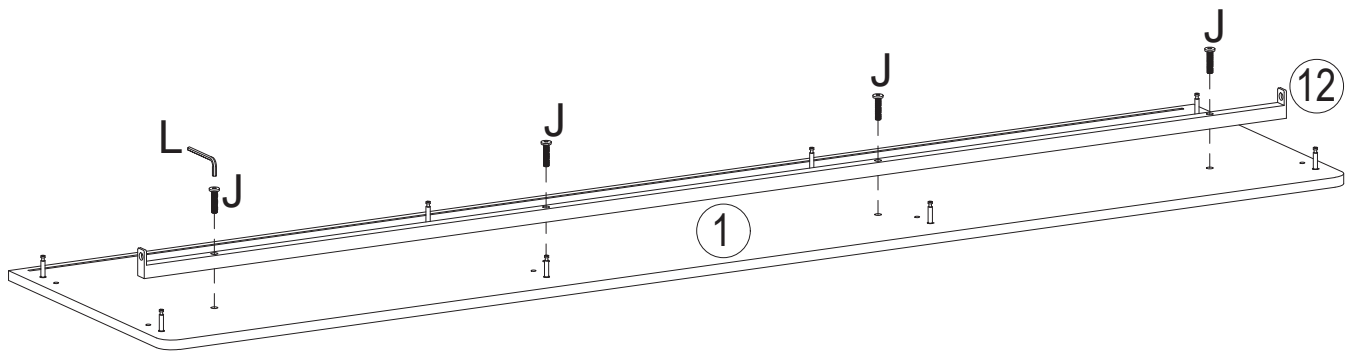

No. A  
Quantity: 8 PCS  
Cam Bolt  
ø6x33.5mm

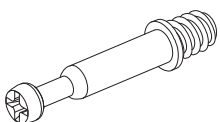

No. J  
Quantity: 4 PCS  
Bolt  
M6x25mm

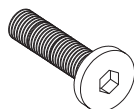

No. L  
Quantity: 1 PCS  
Hex Key  
4mm



# STEP 2

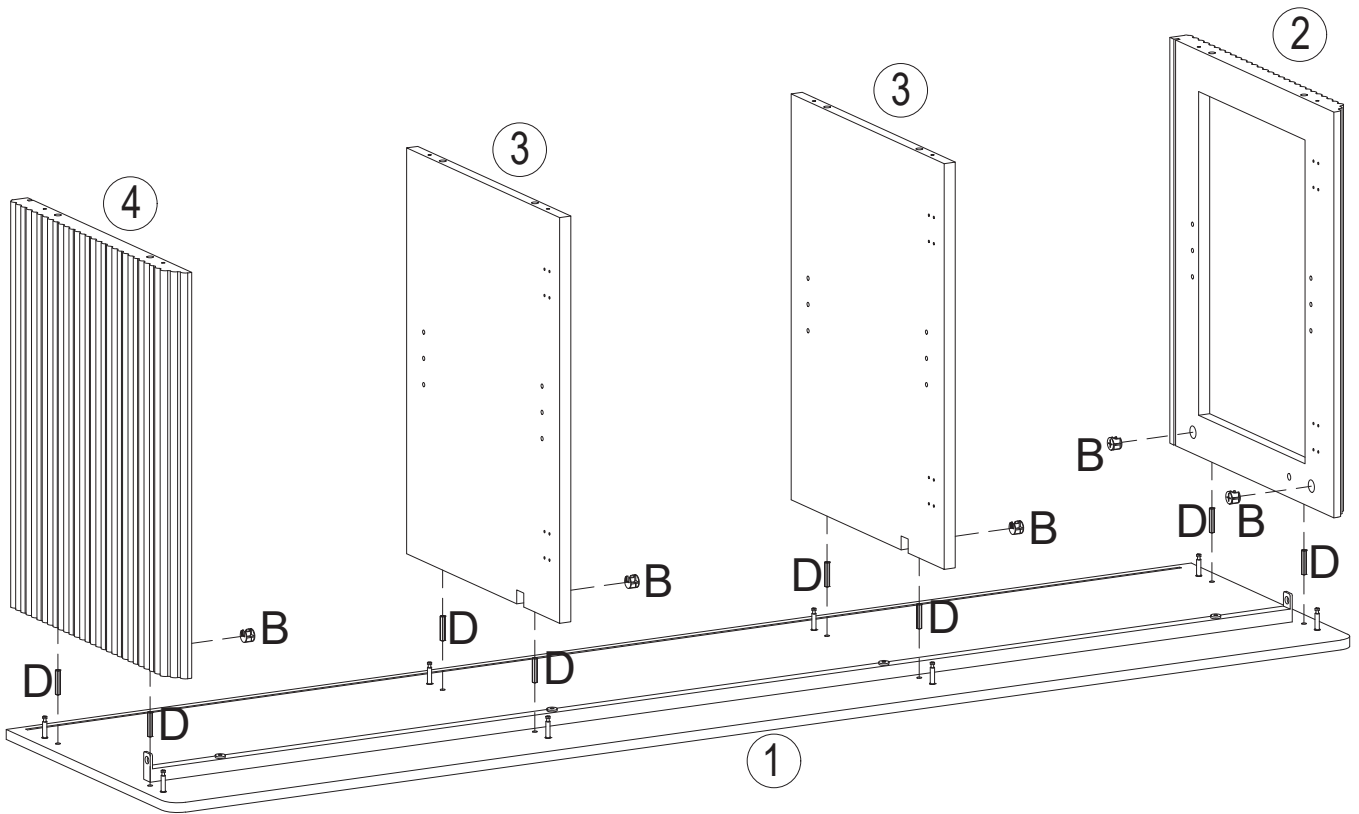

No. B  
Quantity: 8 PCS  
Cam  
ø15x9.5mm



No. D  
Quantity: 8 PCS  
Dowel  
ø6x30mm

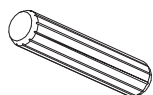

# STEP 3

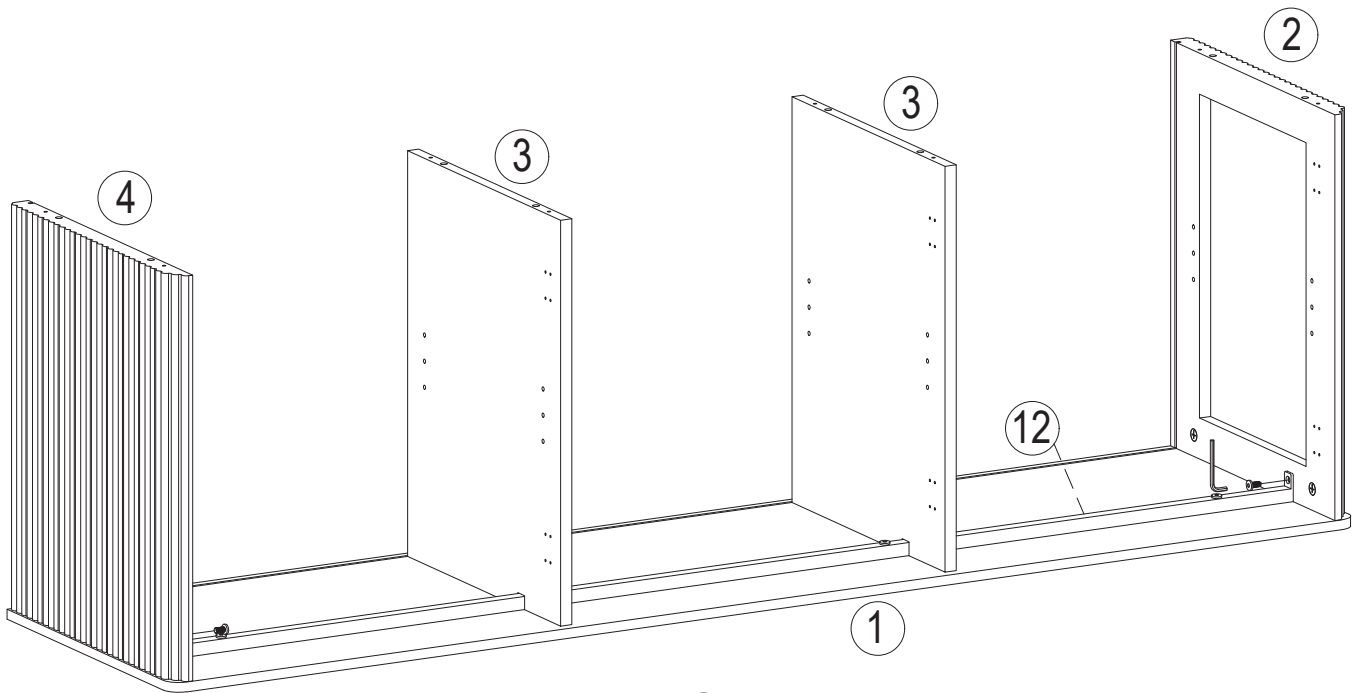

**NOTE:**  
Tighten all Bolt (J and K) In the #12

**No. K**  
Quantity: 2 PCS  
Bolt  
M6x12mm

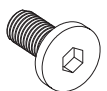

**No. L**  
Quantity: 1 PCS  
Hex Key  
4mm



# STEP 4

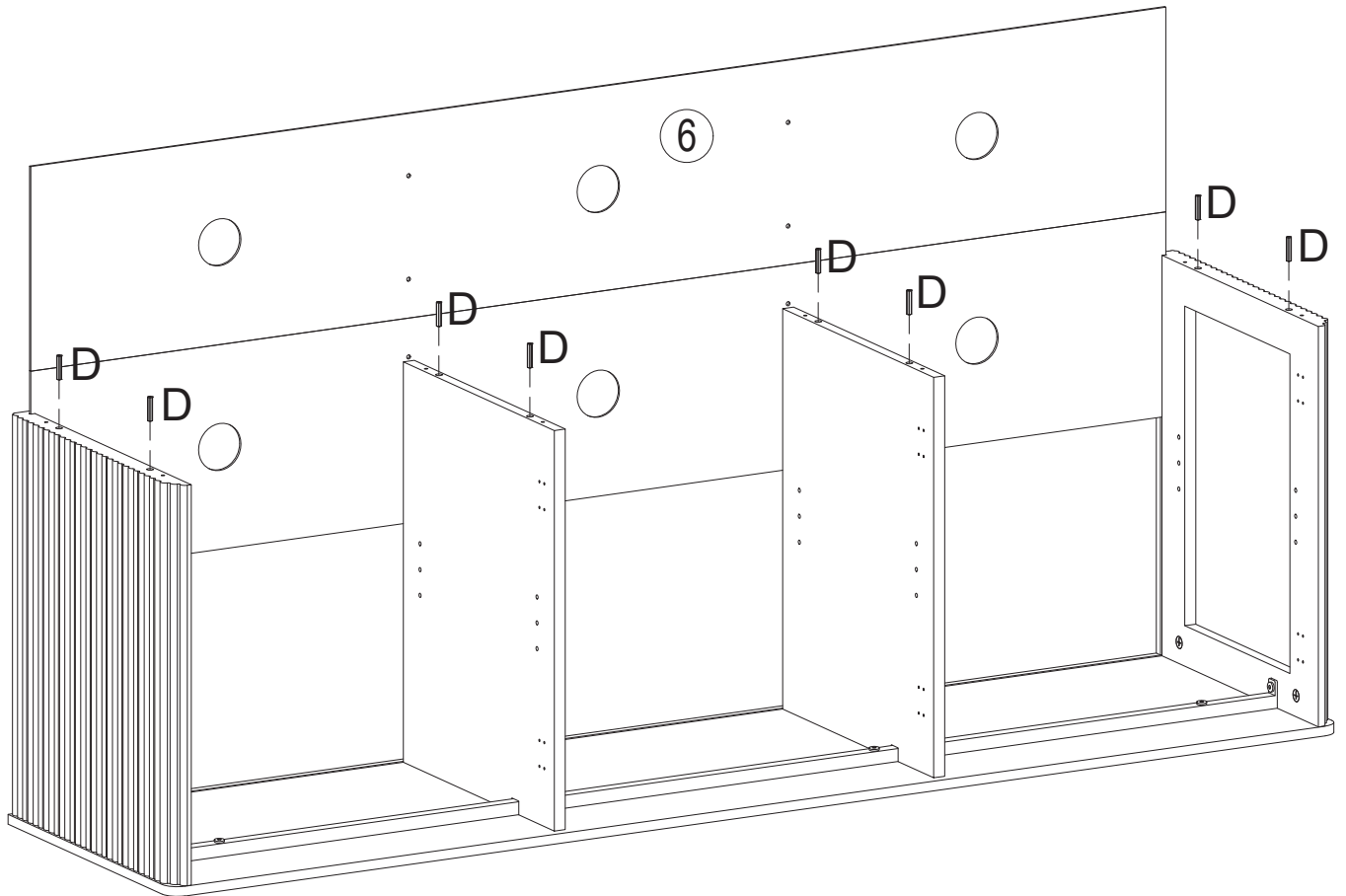

No. D  
Quantity: 8 PCS  
Dowel  
ø6x30mm

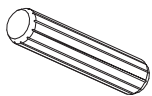

# STEP 5

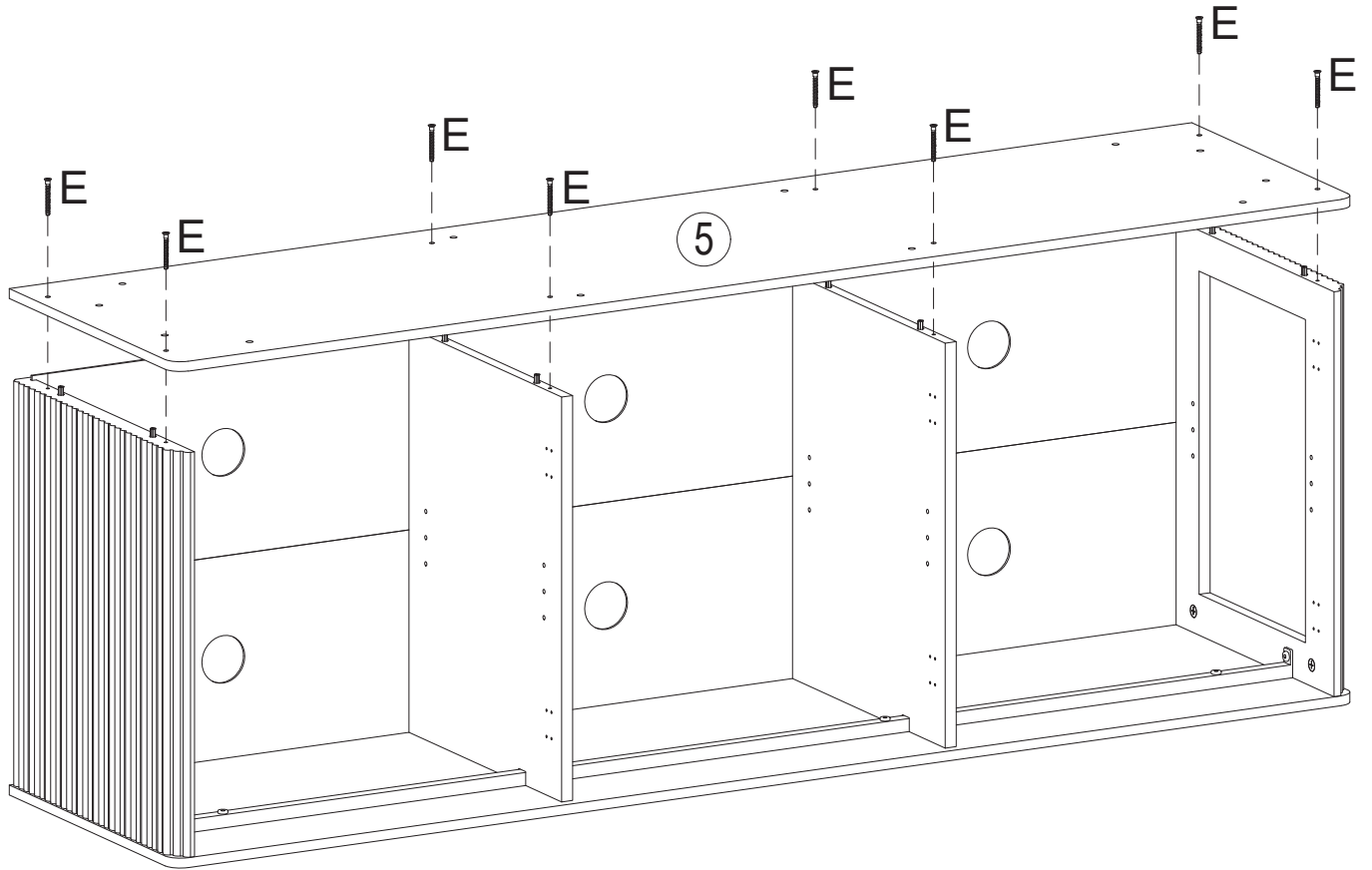

No. E  
Quantity: 8 PCS  
Screw  
ø5x48mm

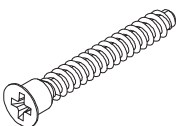

# STEP 6

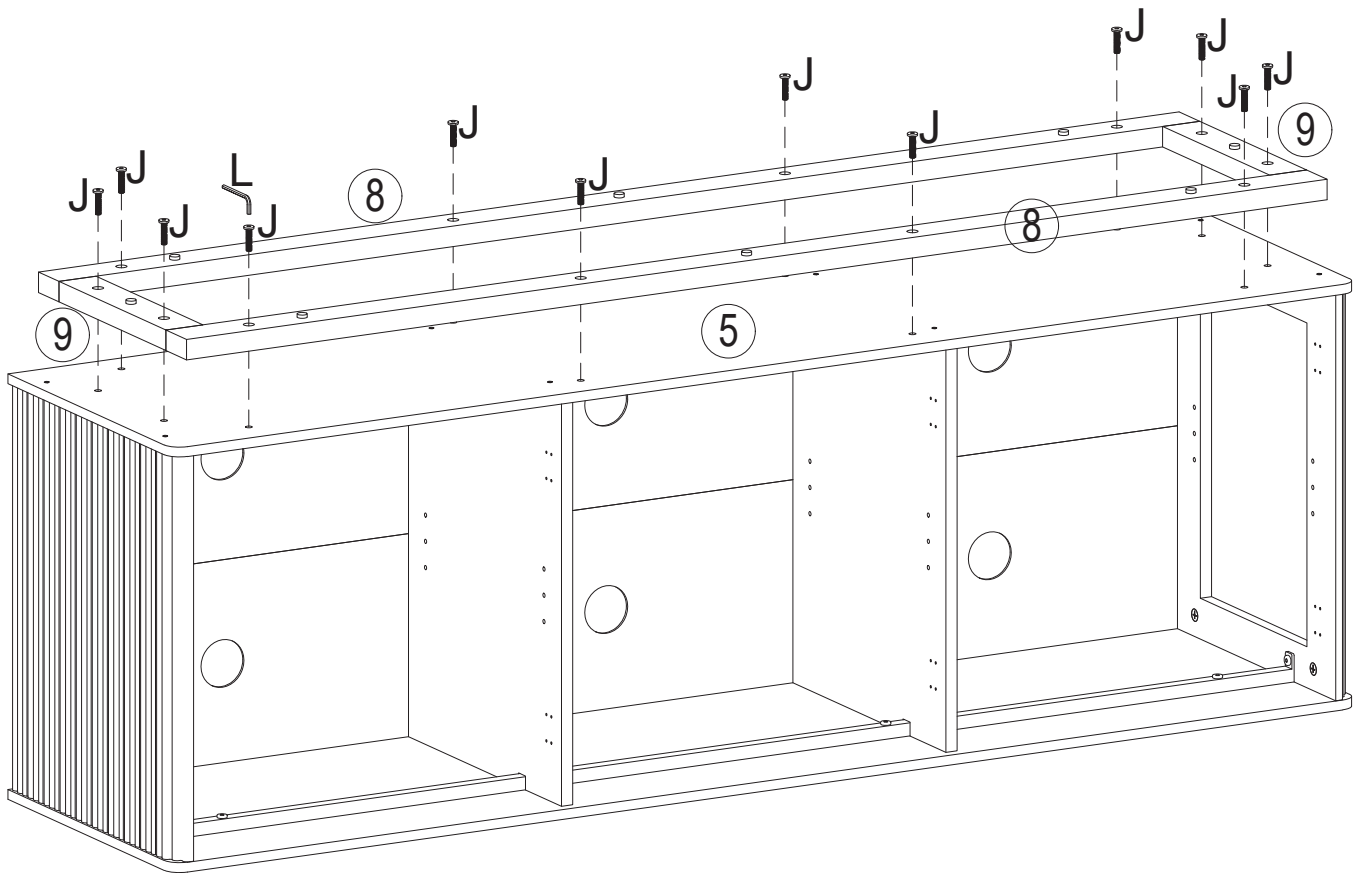

**No. J**  
Quantity: 12 PCS  
Bolt  
M6x25mm

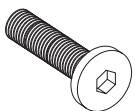

**No. L**  
Quantity: 1 PCS  
Hex Key  
4mm



# STEP 7

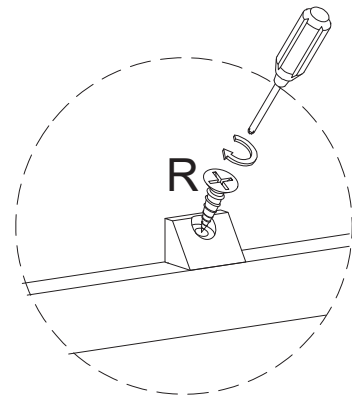
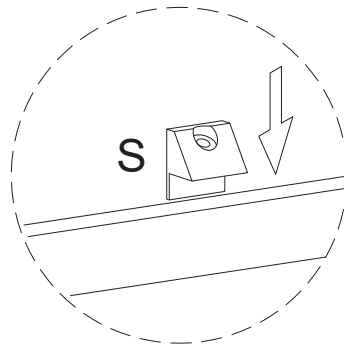
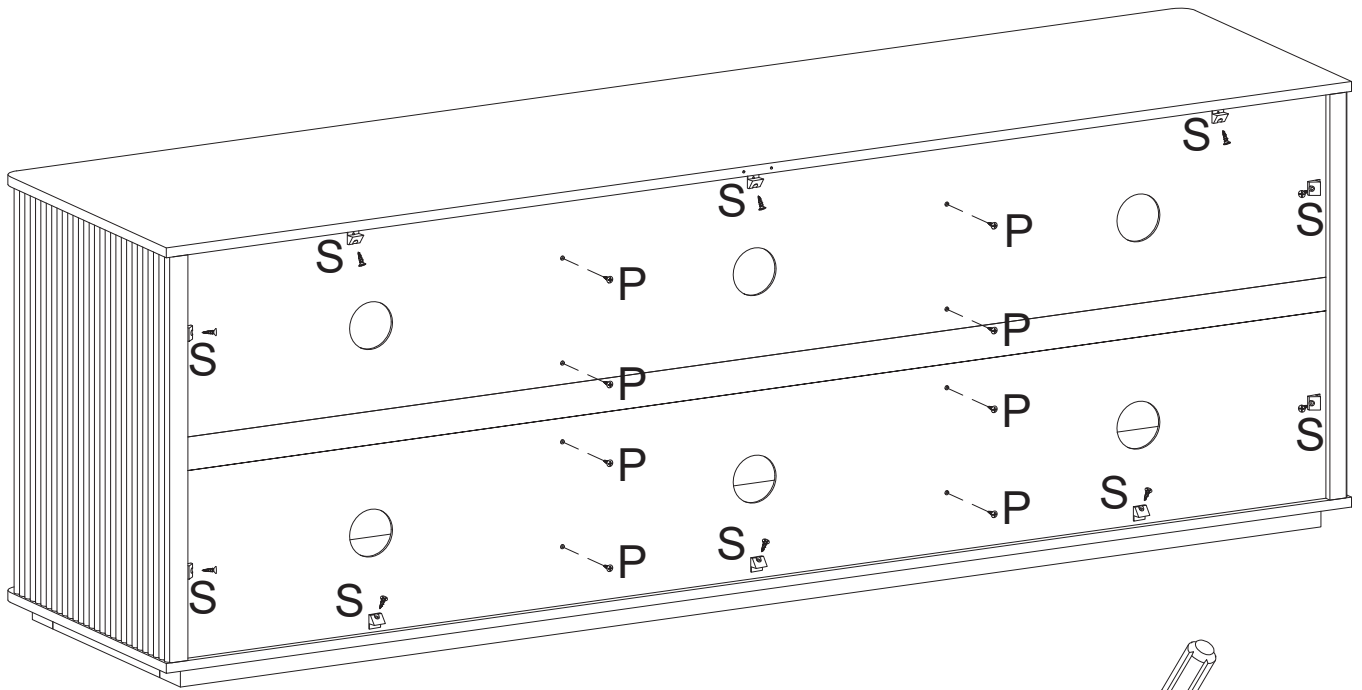

**No. P**  
Quantity: 8 PCS  
Screw  
ø4x12mm

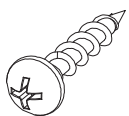

**No. R**  
Quantity: 10 PCS  
Screw  
ø3x16mm

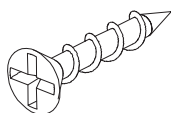

**No. S**  
Quantity: 10 PCS  
Back Buckle  
15x15x10mm

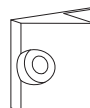

# STEP 8

## NOTE:

Please insert #7 boards before installing the door.

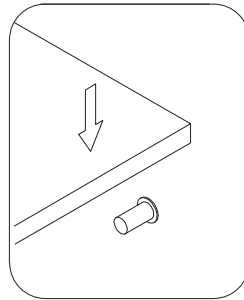
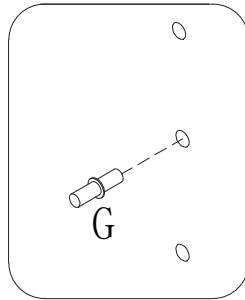
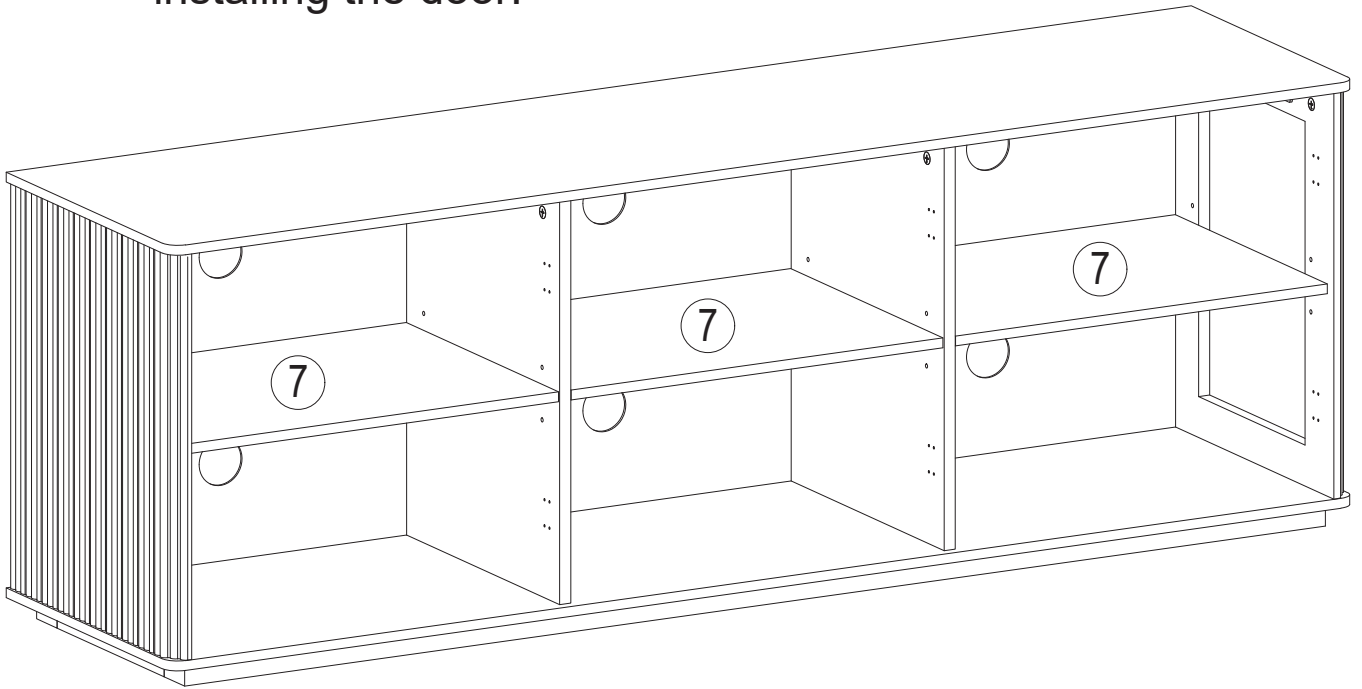

No. G

Quantity: 12 PCS

Screw  
ø5x16mm

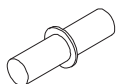

# STEP 9

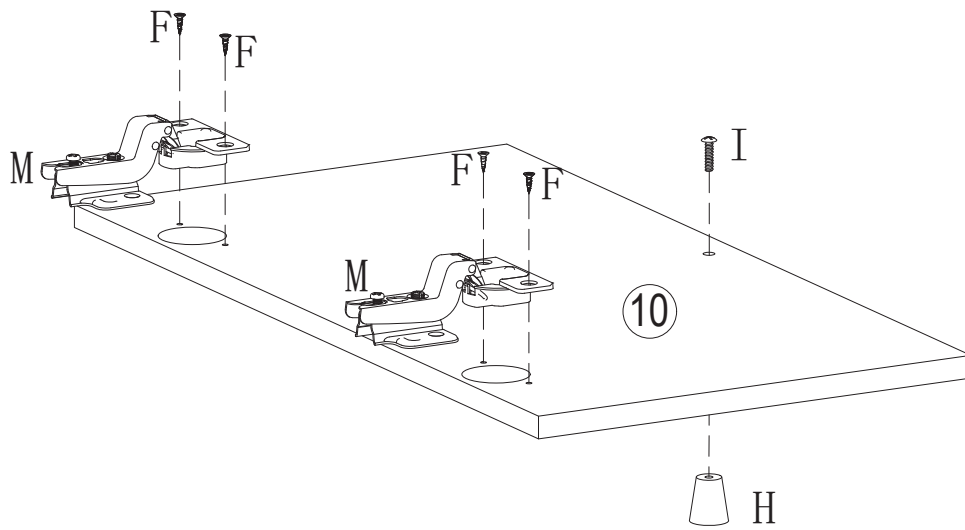

x1

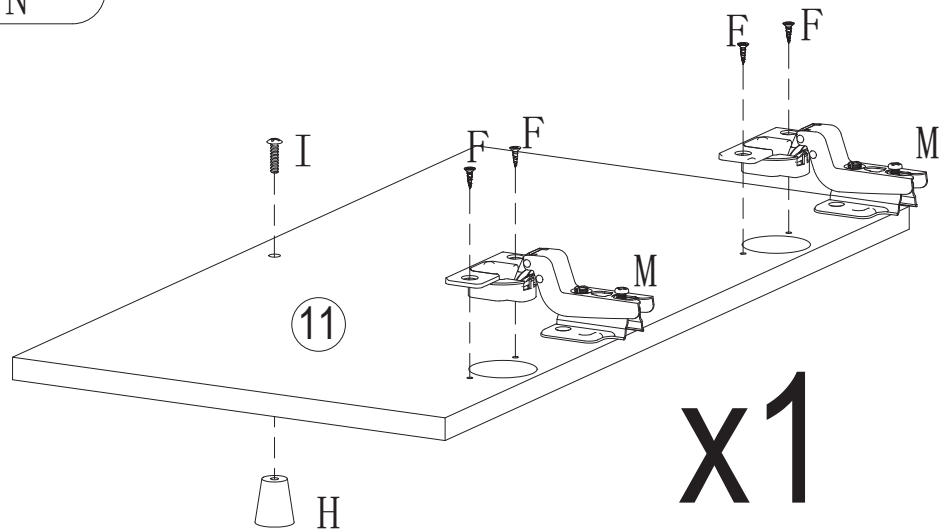
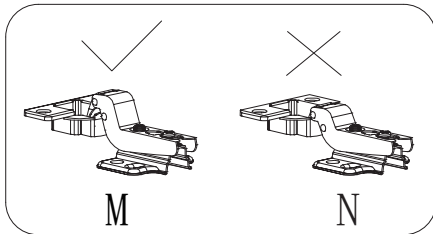

x1

**No. M**  
Quantity: 4 PCS  
Hinge  
ø35mm

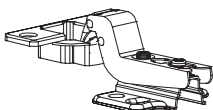

**No. F**  
Quantity: 8 PCS  
Screw  
ø3.5x14mm

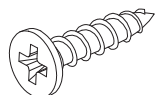

**No. H**  
Quantity: 2 PCS  
Handle  
ø20x23mm

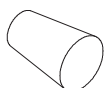

**No. I**  
Quantity: 2 PCS  
Screw  
M4x16mm

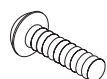

# STEP 10

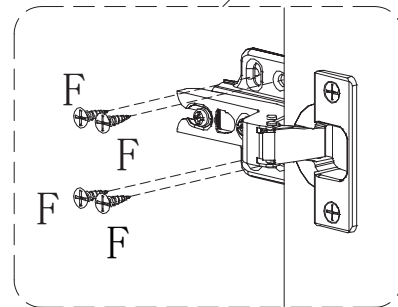
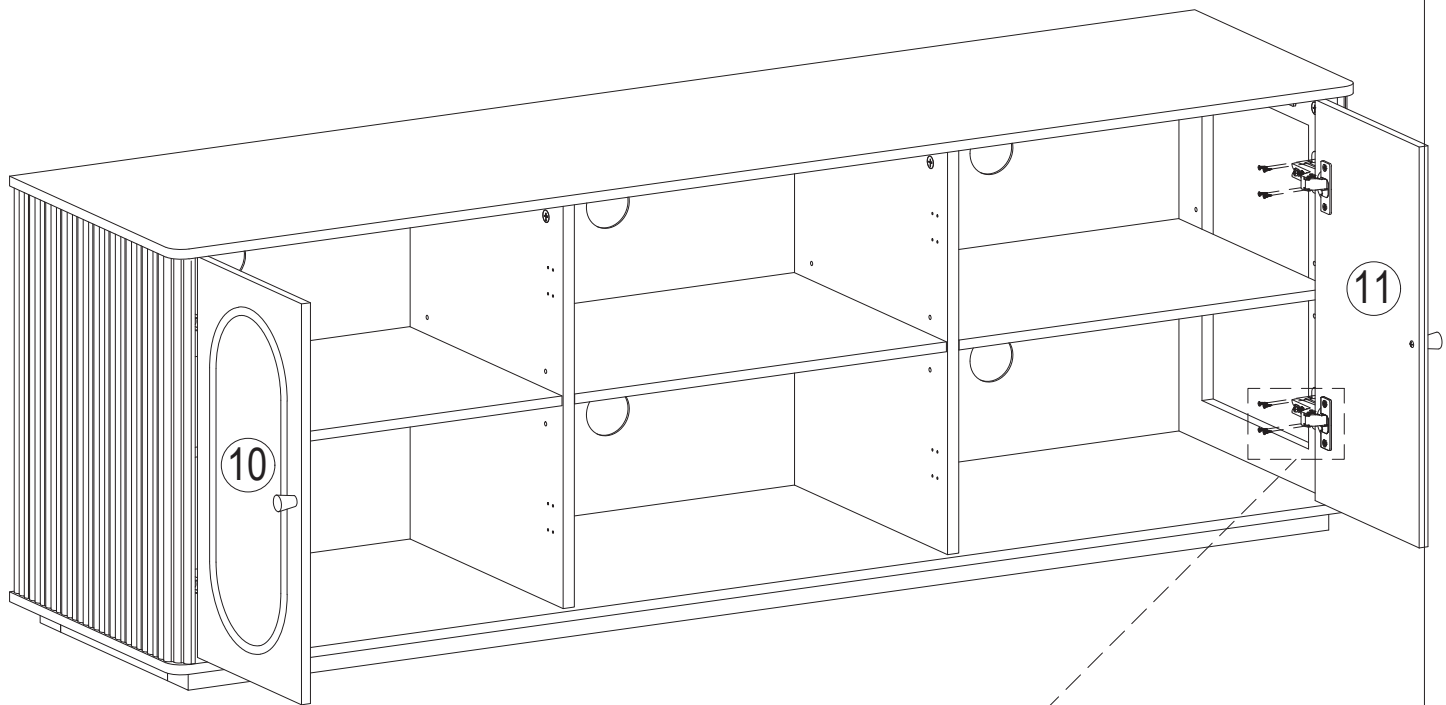

No. F  
Quantity: 16 PCS  
Screw  
ø3.5x14mm

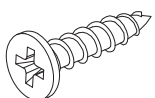

# STEP 11

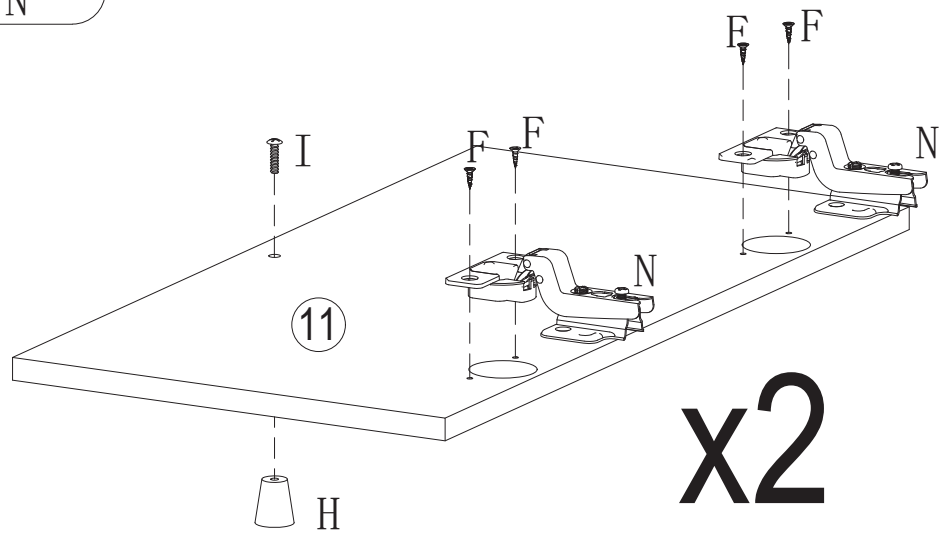
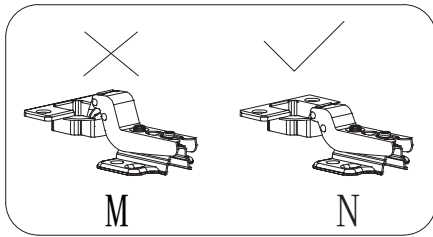

**No. N**  
Quantity: 4 PCS  
Hinge  
ø35mm

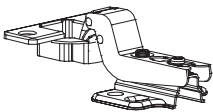

**No. F**  
Quantity: 8 PCS  
Screw  
ø3.5x14mm

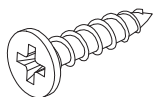

**No. H**  
Quantity: 2 PCS  
Handle  
ø20x23mm



**No. I**  
Quantity: 2 PCS  
Screw  
M4x16mm

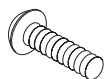

# STEP 12

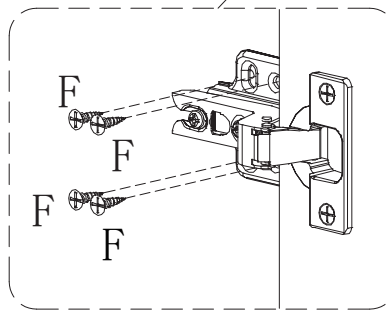
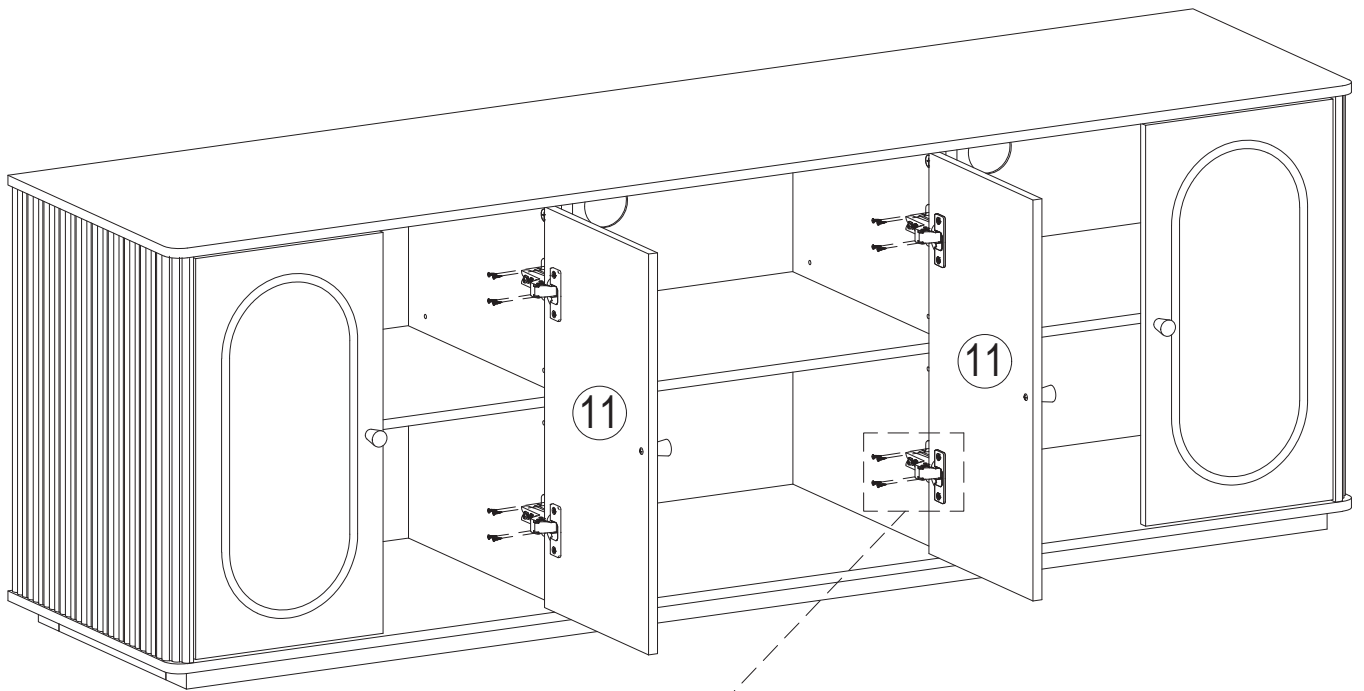

No. F  
Quantity: 16 PCS  
Screw  
ø3.5x14mm

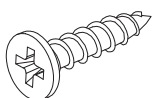

# STEP 13

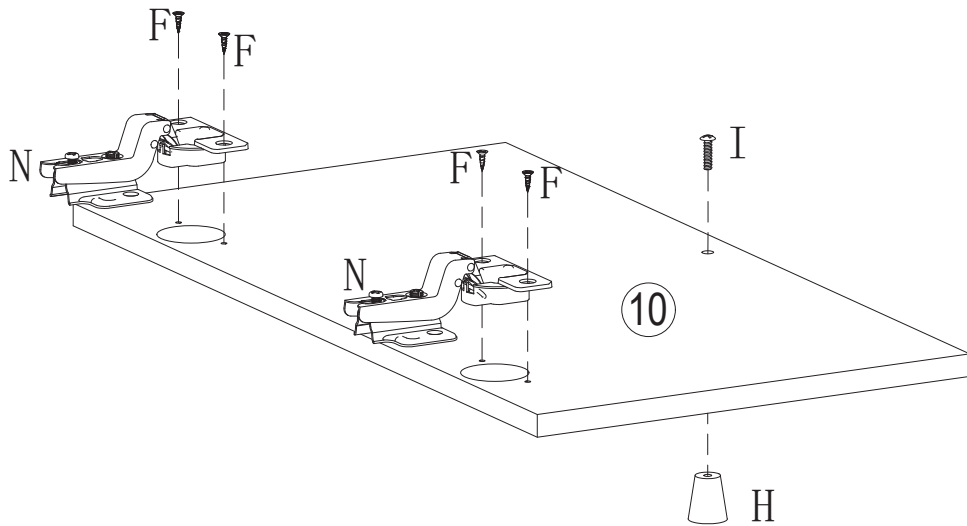

x2

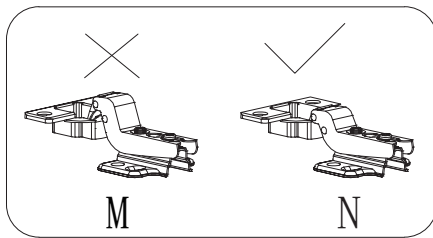

**No. N**  
Quantity: 4 PCS  
Hinge  
ø35mm

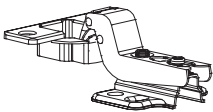

**No. F**  
Quantity: 8 PCS  
Screw  
ø3.5x14mm

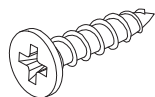

**No. H**  
Quantity: 2 PCS  
Handle  
ø20x23mm



**No. I**  
Quantity: 2 PCS  
Screw  
M4x16mm

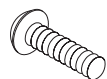

# STEP 14

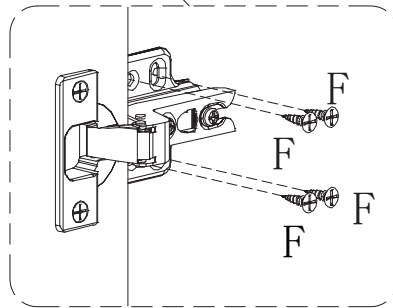
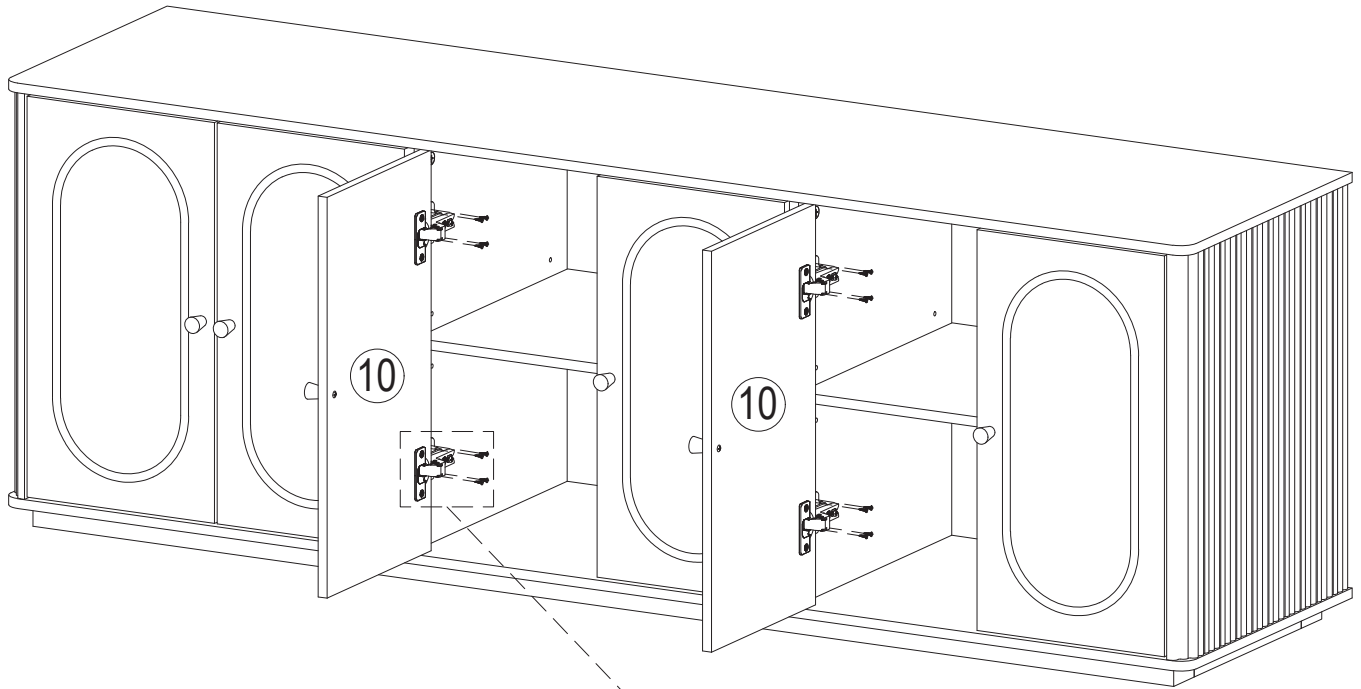

No. F  
Quantity: 16 PCS  
Screw  
ø3.5x14mm

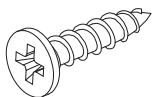

# STEP 15

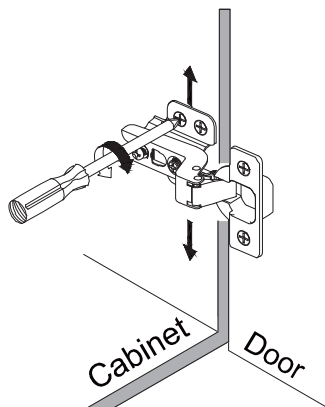
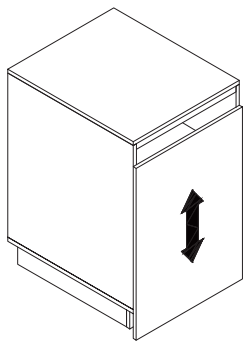
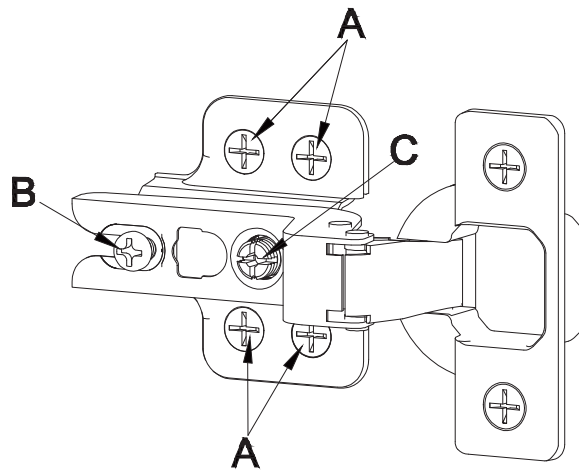

## To adjust the vertical height.

Loosen the four screws "A" on both hinges. Two of them are usually in slotted holes which allows you to adjust up or down by a few mm. Then tighten back up.

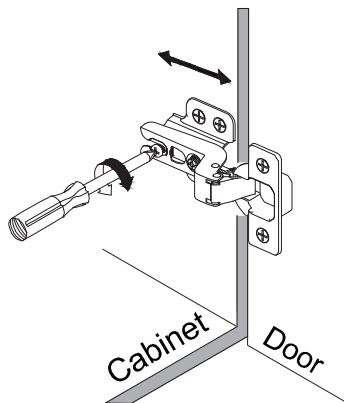
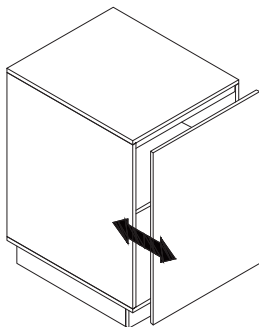

## To adjust depth.

Loosen screw "B" and adjust door, if the door can not be adjusted, please loosen screw "C", then try again. Tighten screw "B" and "C".

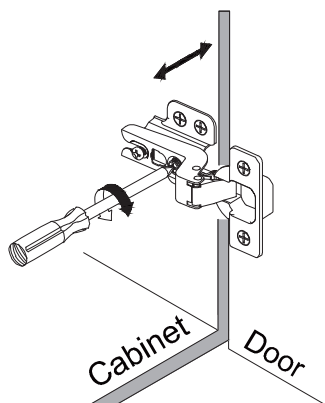
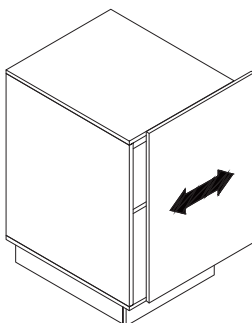

## To adjust side ways.

Turning the screw "C" on BOTH hinges on each door.

# STEP 16

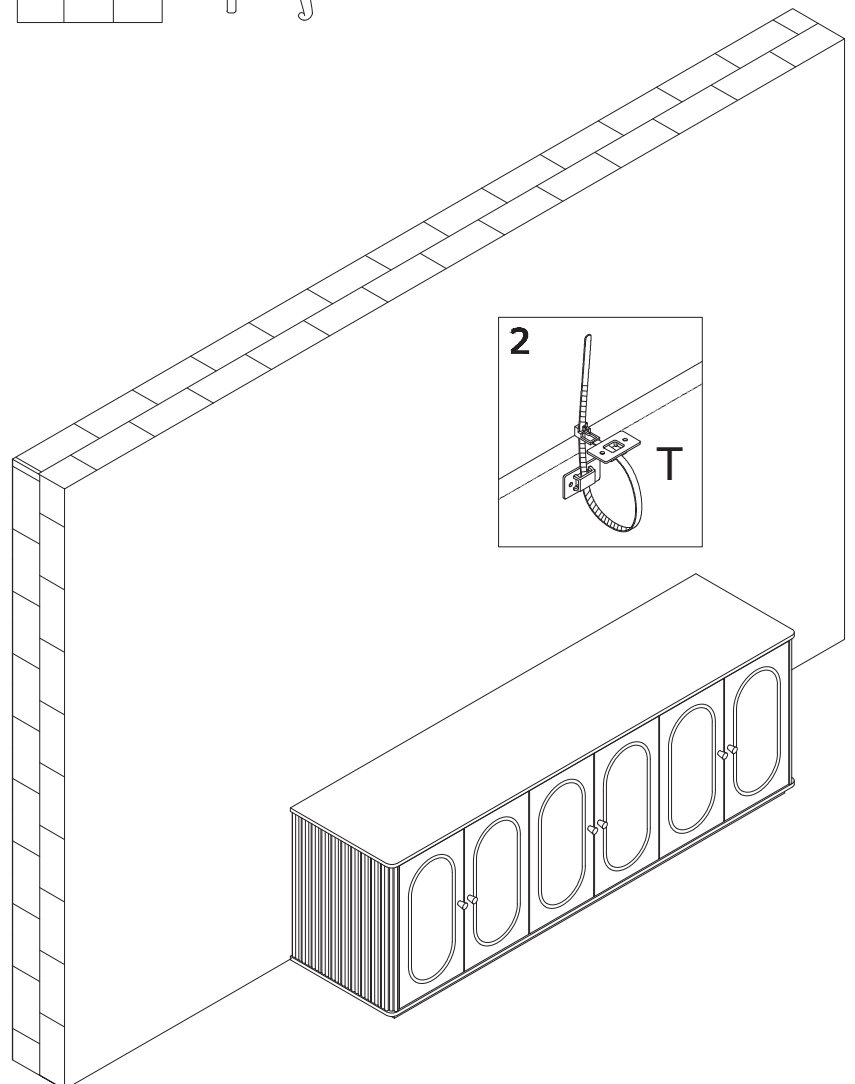
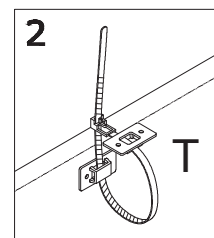
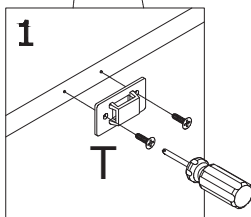
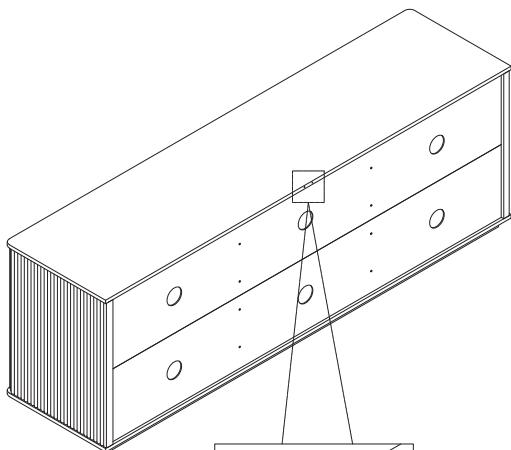
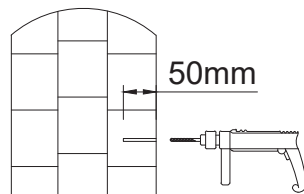
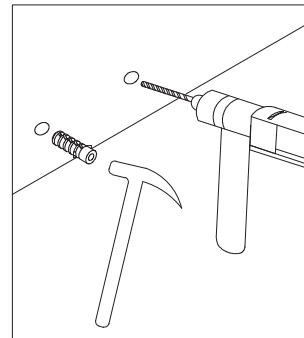
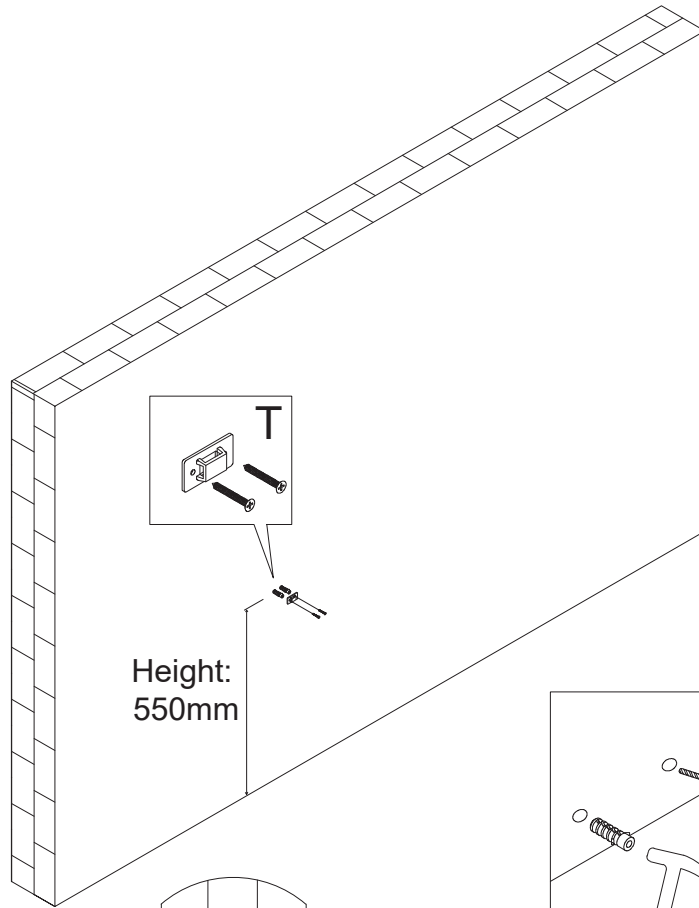

No. T  
Quantity: 1 Set

