

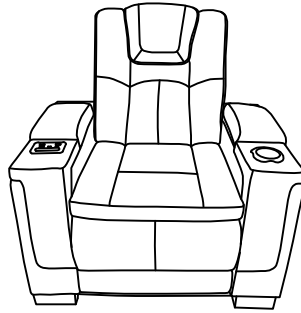

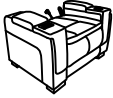

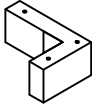

ASSEMBLY INSTRUCTIONS

Caution: Please read instructions thoroughly before unpacking assembly parts.
 Sharp, exposed staple tips can cause injury, therefore, for your protection, please remove any exposed staple used in packing

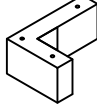

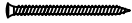
PARTS LIST:

NO.	DESCRIPTION	SKETCH	LOCATED IN	QTY	NO.	DESCRIPTION	SKETCH	LOCATED IN	QTY
A	RECLINER BODY		BOX 1 OF 1	1PC	D	LEFT LEGS		BOX 1 OF 1	2PCS
B	BACK REST		BOX 1 OF 1	1PC	E	RIGHT LEGS		BOX 1 OF 1	2PCS
C	ADAPTER		BOX 1 OF 1	1PC	F	SCREW M5X55MM		BOX 1 OF 1	12PCS
						NOT INCLUDED			

Assembly Tips:

- Identify all parts and components are complete based on the list above
- This assembly may require additional help (2 person set up)
- Be careful when sliding down wings and backs to avoid ripping the material with the rails

STEP 1

Screw legs (D) and (E) to Recliner body (A) as show below diagram .
Use screw driving machine to screw (F) to left legs (D)& right legs (E) to Recliner body (A) as show below diagram .

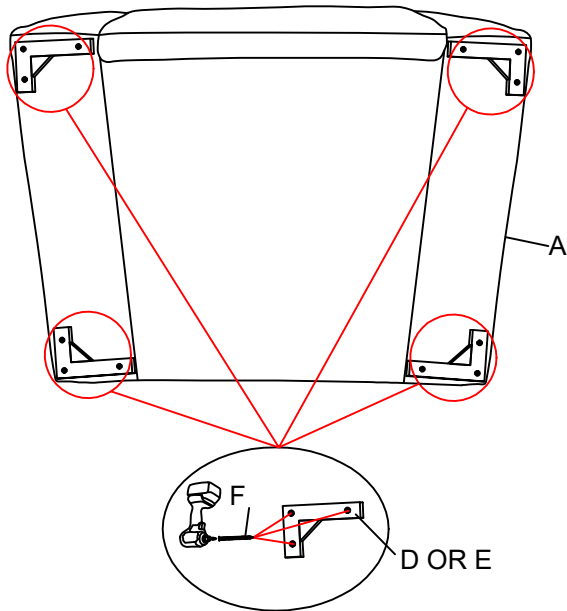

STEP 2

Align and connect the extension wire from the BACK REST to the BODY. Install the BACKREST (B) to the RECLINER BODY (A)

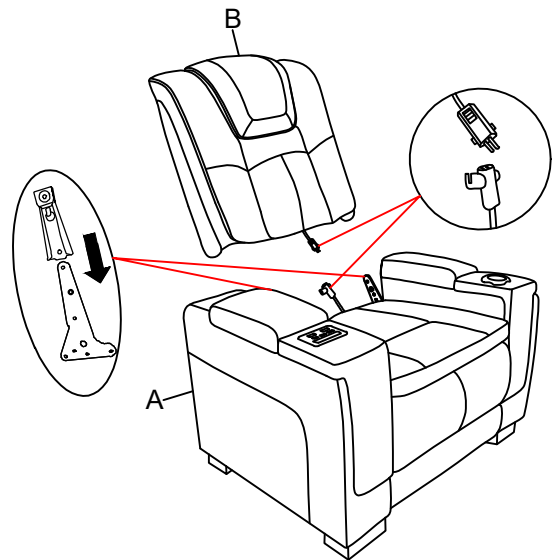

STEP 3

Connect the extension wire of the ADAPTER (C) to the wires on the back of seat. Plug the ADAPTER (C) into the wall outlet. Press the button on control panel to adjust the Recliner.

