

ASSEMBLY INSTRUCTIONS

WOVEN BENCH

A Bench

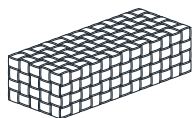

1 pc

B Leg



4 pcs

C JCBC Bolt
M6 x 50mm

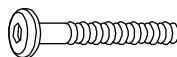

4 pcs

D Wood Dowel
M8 x 30mm



4 pcs

E Allen Key
M4 x 100mm



1 pc

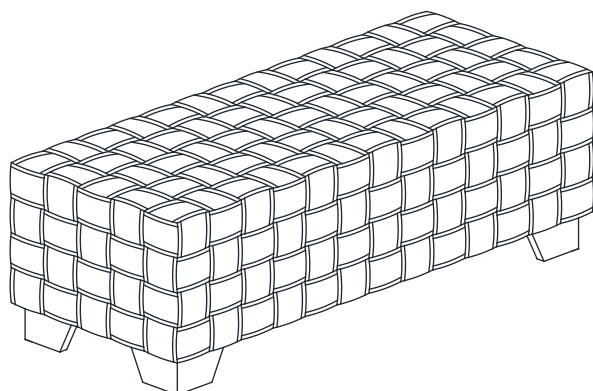

This page lists all the contents included in the box. Please take the time to identify the hardware as well as the individual components to this product. As you unpack and prepare for assembly, place the contents on a carpeted or padded area to protect them from damage.

-
- 1** First, knock Wood Dowel (D) into the Leg (B) with a hammer (not provided). Then, attach the Leg (B) to the Bench (A) using JCBC Bolt (C) with the Allen Key (E).

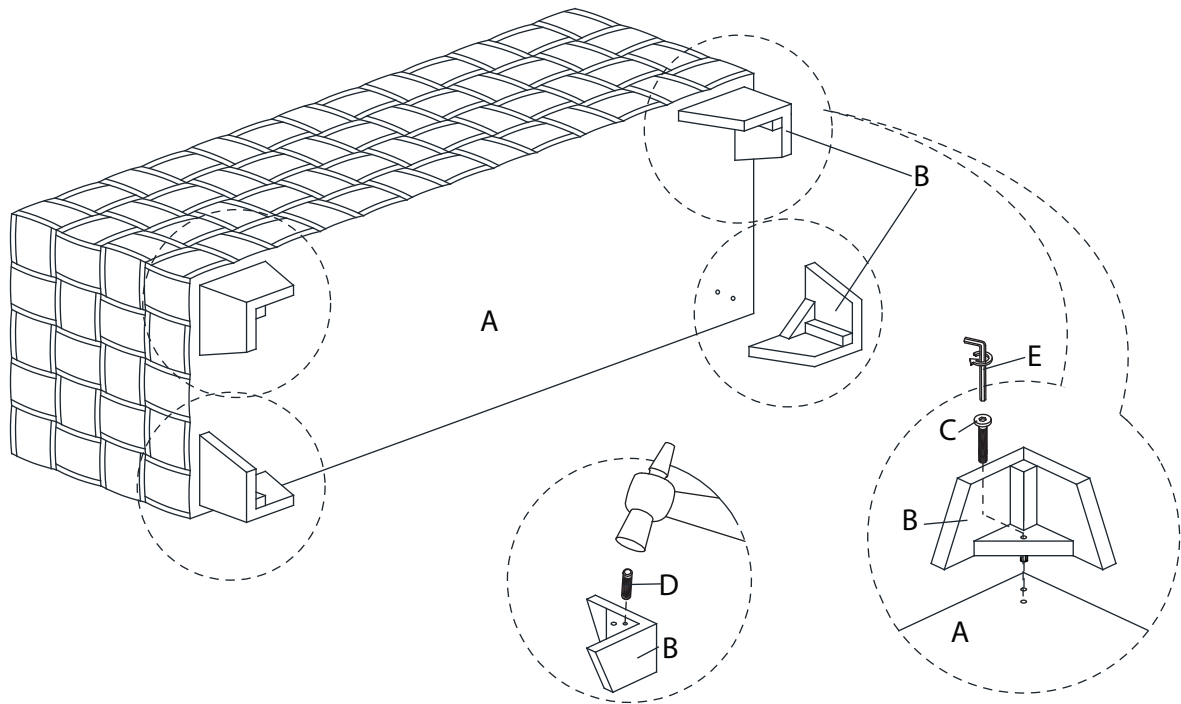

Cleaning & Care

Treat surfaces with care. Surfaces are resistant to scratches but are not scratch resistant. Clean surfaces with a dry or damp soft cloth. Do not use abrasive cleaners. Hardware may loosen over time. Periodically check that all connections are tight.