

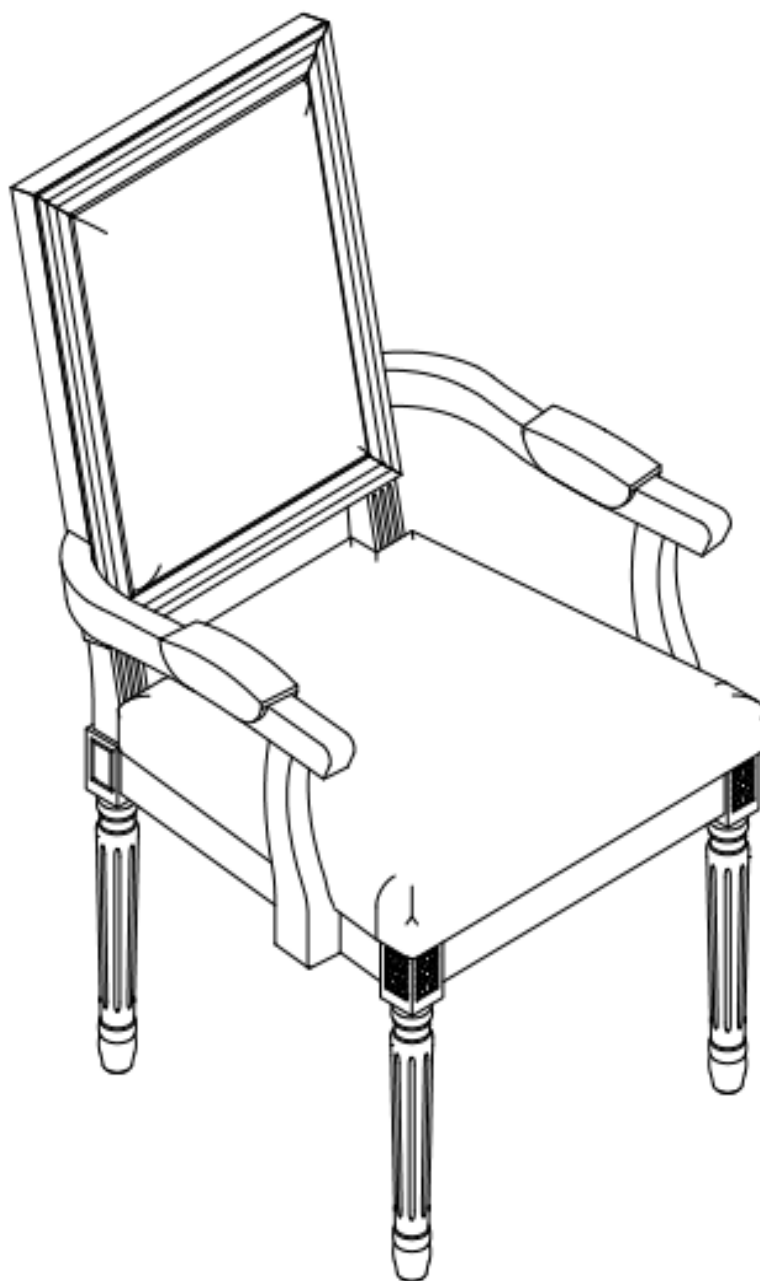





Assembly Instructions

Caution : You must read this before you proceed



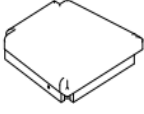





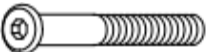

Dining Chair



Parts List

Label	Picture	Description	QTY
A		Chair Back	1
B		Chair Seat	1
C		Front Leg	2
D		Arm-Left	1
E		Arm-Right	1

Hardware

Label	Picture	Description	QTY
①		Bolt (M8*50mm)	4
②		Bolt (M8*65mm)	5
③		Bolt (M8*80mm)	5
④		Spring Washer (M8)	14
⑤		Flat Washer (M8)	14
⑥		Bolt (M6*43mm)	3
⑦		Spring Washer (M6)	3
⑧		Flat Washer (M6)	3
⑨		5mm Allen Wrench	1
⑩		4mm Allen Wrench	1
⑪		Plug	2

Assembly Preparation

Before Beginning Assembly:

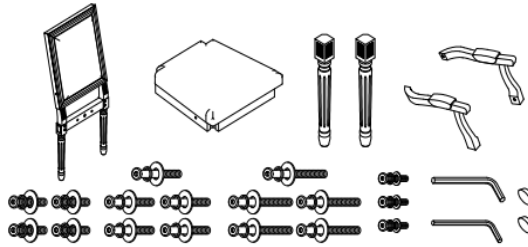

- Read instructions, cover to cover-



- Have 2 adults on hand for assembly-



- Do not assemble on flooring or carpet-



- Assemble on a clean non-marring surface (packing foam)-



- Save all packaging until finished-

Assembly Steps

Overview

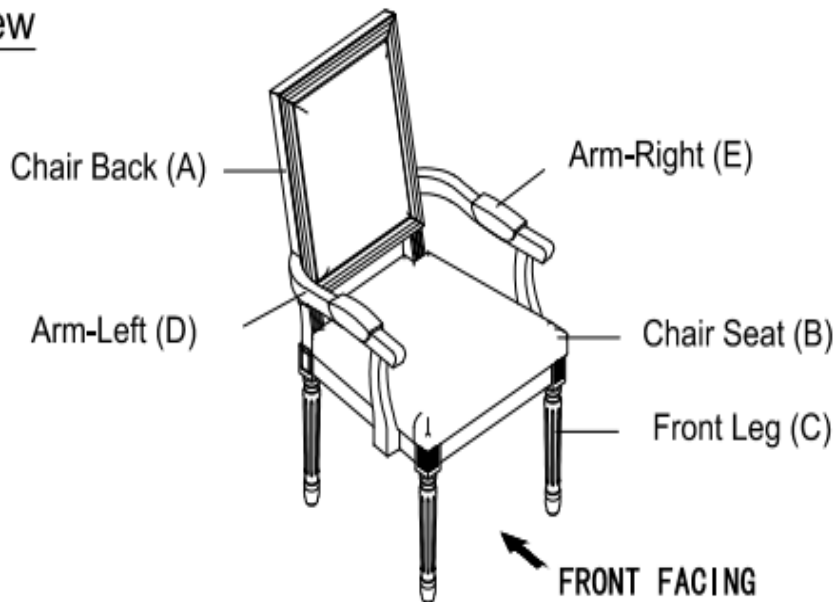

This Dining Chair has multiple parts and may require up to 30 minutes to assemble. To give you an overview of the Dining Chair parts, the above picture is to help you put the various parts into perspective. Please read through the instructions below to familiarise yourself with the parts and steps before assembly

Step 1

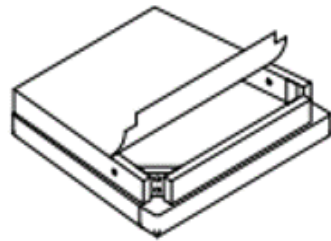

B



C

REMOVE the Seat Base Cover from the Chair Seat(B), and take out the front legs(C). Place all the parts on a clean, non-marring surface.

Step 2

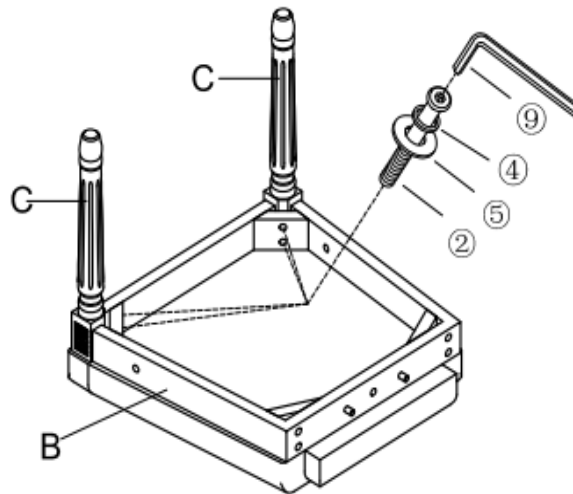

You will now have the Chair Seat bottom (B) and have the Front Legs(C) facing upwards.

Insert the Front Leg(C) completely vertical into the seat frame corner using 4 Bolts 65mm② + 4 Spring Washers④+ 4 Flat Washers⑤ and the Allen Wrench⑨.

At this point in the assembly. DO NOT fully tighten the connections.

Step 3

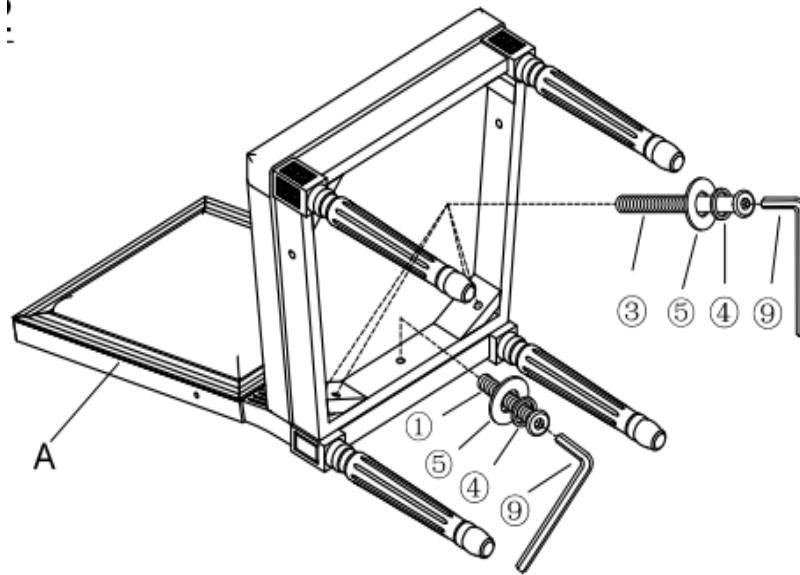

Place the Chair Back(A) on a clean, non-marring surface.
Align the mounting positions on the Seat(B) to the mountings on the Back with the Legs(A).

Lock the middle mounting position, using 1 Bolt 50mm ①+1 Spring Washer④ and 1 Flat Washer⑤ with the Allen Wrench⑨.

Lock the corner four mounting positions and attach them using 4 Bolts 80mm③+4 Spring Washers④ +4 Flat Washers⑤ with the Allen Wrench ⑨, as shown on the picture above.

Friendly notice:

If the mounting positions cannot be aligned well which hinders the installation, then sway the Seat(A) lightly when locking the Bolts, this action could help prevent the Bolts from getting stuck and ensure a smooth assembly.

Do not fully tighten the Bolts.

Step 4

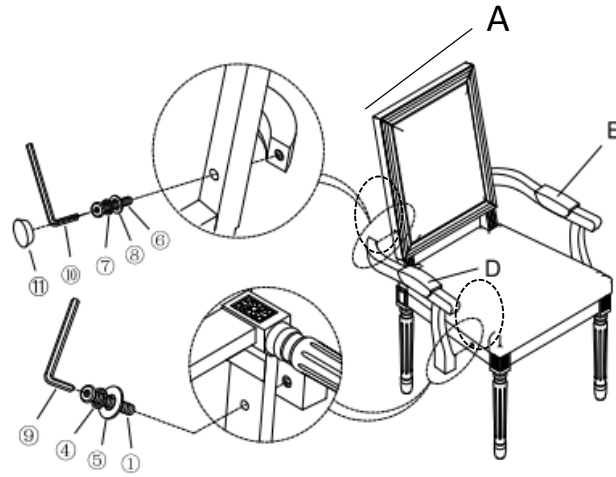

Position the Chair Back(A) as shown in the picture.
Align the mounting positions of the Arm(D&E) with the Chair Back(A)
Backrest position: 2 Bolts 43mm⑥ + 2 Spring Washers⑦+ 2 Flat Washers⑧ and the Allen Wrench⑩. Press the Plug⑪ into the position
Seat frame position: 2 Bolts 50mm①+ 2 Spring Washers④+ 2 Flat Washers⑤ and the Allen Wrench⑨.
Repeat the same process with the Right Arm(E).
Note: DO NOT fully tighten the Bolts

Step 5

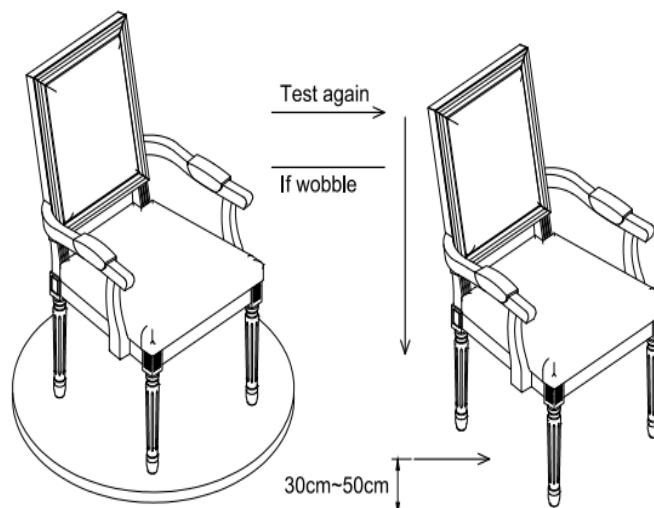

Place the Chair on a level Surface to check for wobbles.
If it wobbles, lift the Chair some 30cm to 50cm high from the ground.
Keep your feet and toes well away from the drop zone.
Drop Chair freely and vertically, with all four legs hitting the ground at the same time.
This Drop Test will help to ensure that all Bolts and gaps reach full alignment status.
Test again for evenness on a Level Surface.
If no wobbles are found, proceed to tighten all the Bolts.
When tightening the Bolts, tighten sequentially.
Do not fully tighten any Bolt fully and then move on towards the next one. This may cause the frame to warp.
If there is still wobbles, loosen the Bolts and execute this same drop test.

Step 6

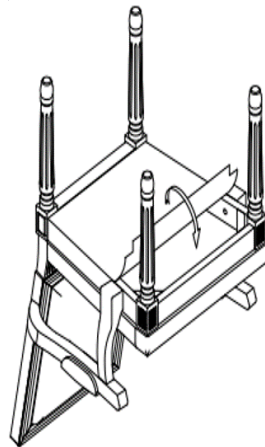

Place the Seat Base Cover back as shown in picture.
Smooth the Velcro down, Make sure all parts are connected and securely locked into position.

Step 7

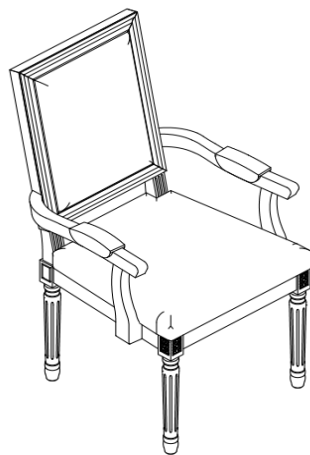

Your Chair is ready for use.
This Arm Chair can only be used on a flat, level surface.

Care & Maintenance



- Furniture may scratch floors. We recommend using furniture pads to protect your floors.



- Do not put hot items directly on furniture surface.



- Do not clean furniture with harsh cleansers or polish.



- Do not place furniture under direct sunlight.



- Do not place furniture near heating or cooling vents.



- Do not write on furniture without a padded barrier to protect the surface.



- Do not place furniture outside . For indoor use only.



- Not for commercial use. For residential use only.



- Stains may be removed with mild soap solution and damp cloth.



- Children should not climb or jump on the furniture.



- Dust and pick-up spills using a clean, non-colored, lint-free cloth.