

# ASSEMBLY INSTRUCTIONS

---

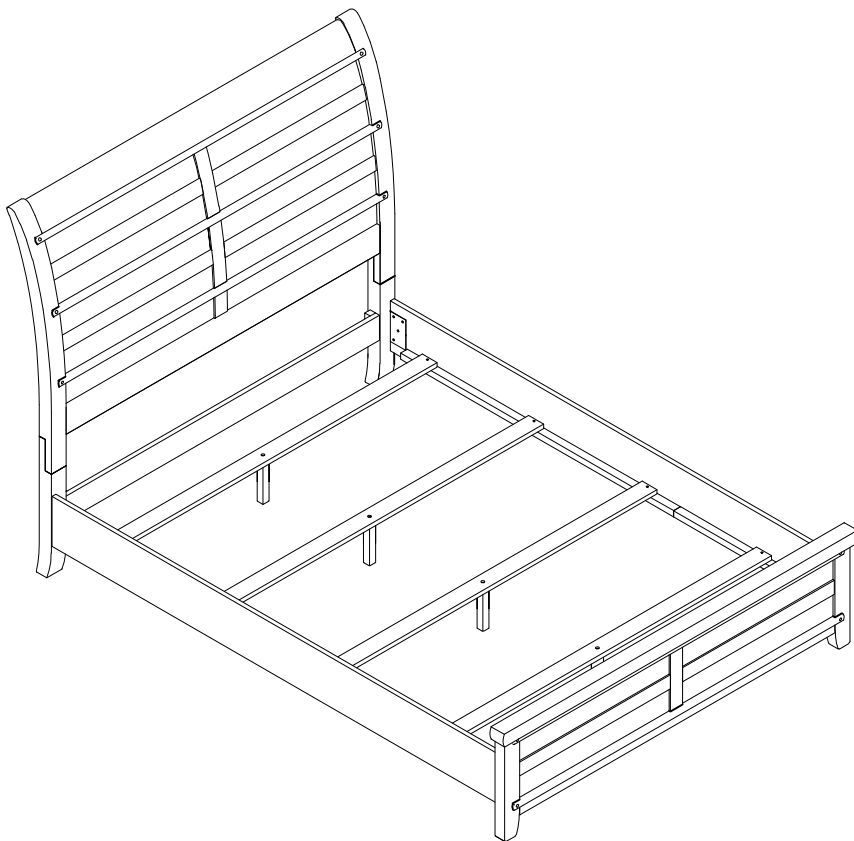

## TOOLS REQUIRED



Allen Wrench  
(Included)



Phillips  
Screwdriver  
(Not Included)



2 - People  
Recommended

## ASSEMBLY RATING



EASY ————— DIFFICULT

The Assembly Rating is a 5-point system showing the level of effort needed to assemble a specific product.

# PRE ASSEMBLY INTRODUCTION

We understand building ready-to-assemble furniture can be a challenging experience for some. To help avoid confusion, we have provided some helpful tips that may speed up the process.



## Teamwork

ALWAYS have at least two people to help with transporting and assembling the product to avoid potential injury and/or damage.



## Suitable Location

Assembling near the area of the intended location is highly recommended.



## Sufficient Space

Make sure you have enough space to move around during the assembly.



## Avoid Scratches

Use cardboard, blankets or a carpeted area while assembling furniture to prevent scratches.



## Flat Surface

Make sure the furniture rests on a flat and level surface with each leg evenly touching the floor.

# ASSEMBLY AND CARE ADVICE



**FAILURE TO FOLLOW THE GUIDELINES BELOW MAY RESULT IN INJURY AND/OR PROPERTY DAMAGE.**



Position each part correctly and insert screws or bolts into their respective holes.

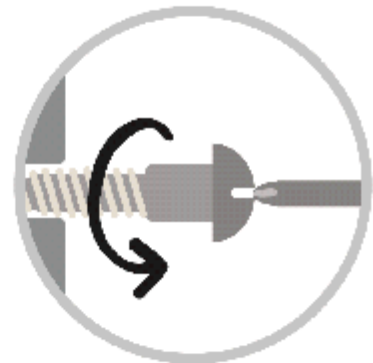

Turn clockwise to tighten and only tighten when step is completed or when instructed to do so.



Use the appropriate hand tools or power tools for assembly. Select steps, such as tightening screws and/or bolts, may require hand tools to avoid causing damage during assembly.



Save the instructions and store any supplied tools for later maintenance.

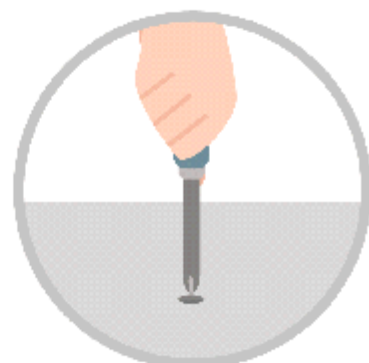

After two weeks, check and tighten any loose hardware and repeat again every six months thereafter.

**IT IS THE USER'S RESPONSIBILITY TO MAINTAIN THE FURNITURE. THE HARDWARE MAY LOOSEN OVER TIME AND MAY CAUSE THE FURNITURE TO BE WOBBLY AND UNABLE TO SUPPORT ITS INTENDED WEIGHT CAPACITY. THIS MAY LEAD TO COLLAPSE AND MAY CAUSE SERIOUS INJURY.**

# BED



- Please keep instructions for future reference.
- Check the quantity and irregularity of parts and hardware before you start.

## PARTS

#1 1pc

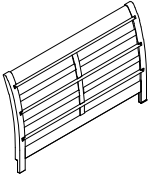

Headboard Panel

#2 2pcs



Leg (R/L)

#3 1pc



Wooden Rods

#4 1pc

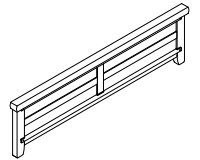

Footboard

#5 2pcs

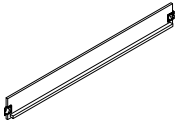

Bed Side Rails

#6 4pcs



Slat

#7 4pcs

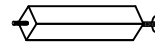

Center Support Leg

## HARDWARE

#A 2pcs

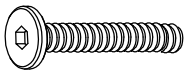

Bolt  
Ø1/4"x38mm

#B 2pcs



Lock Washer  
Ø1/4"

#C 2pcs

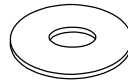

Flat Washer  
Ø1/4"

#D 8pcs

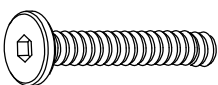

Bolt  
Ø5/16"x40mm

#E 8pcs



Lock Washer  
Ø5/16"

#F 8pcs



Flat Washer  
Ø5/16"

#G 1pc



Allen Wrench  
M4

#H 8pcs

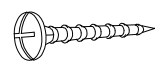





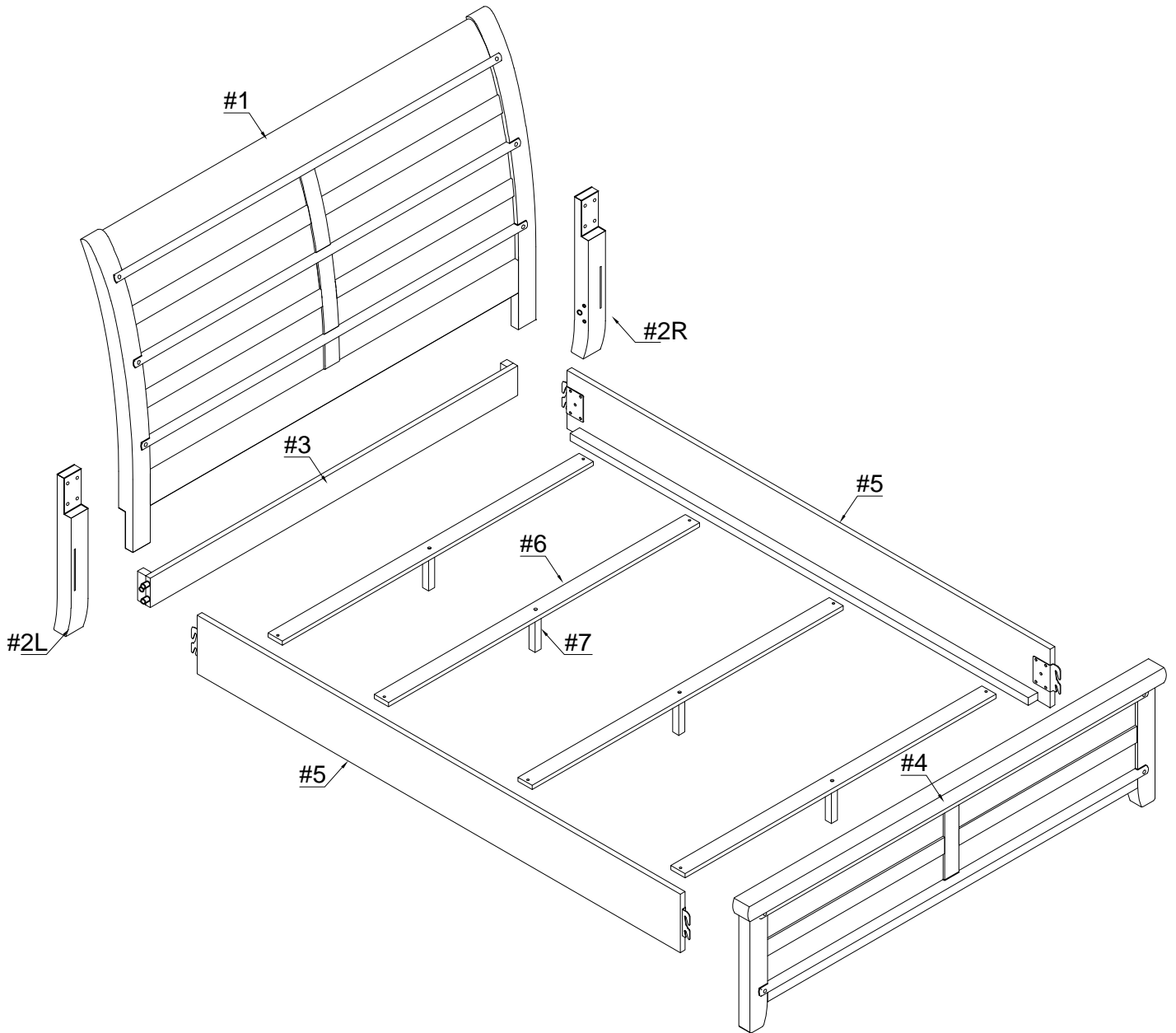



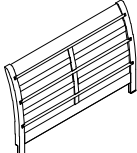

Screw  
4x30mm

# Exploded View

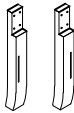
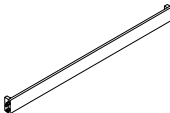
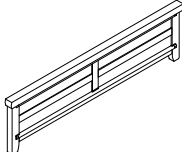

packed in 3 cases

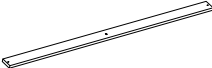
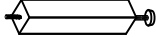
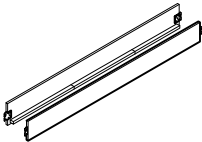
Carton	Disignation	Part	Part	Hardware
	Headboard panel	#1		 #A x2pcs  #B x2pcs  #C x2pcs  #D x8pcs  #E x8pcs  #F x8pcs  #G x1pc
	Leg(R/L)	#2		
	Wooden Rods	#3		
	Footboard	#4		 #H x8pcs
	Slats Rolls	#6		
	Center Support Leg	#7		
	Bed Side Rail	#5		

# ASSEMBLY INSTRUCTIONS

1

- Part #1 x 1pc
- Part #2 x 2pcs
- Part #3 x 1pc
- Hardware #A x 2pcs
- Hardware #B x 2pcs
- Hardware #C x 2pcs
- Hardware #D x 8pcs
- Hardware #E x 8pcs
- Hardware #F x 8pcs
- Hardware #G x 1pc

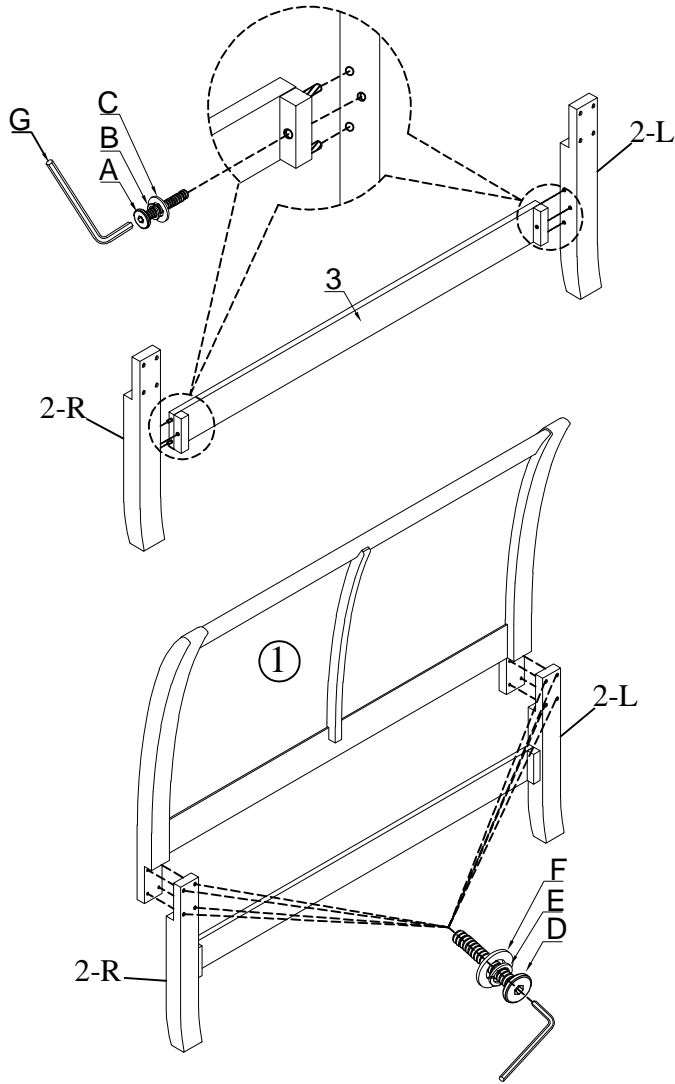

2

- Part #1 x 1pc
- Part #4 x 1pc
- Part #5 x 2pcs

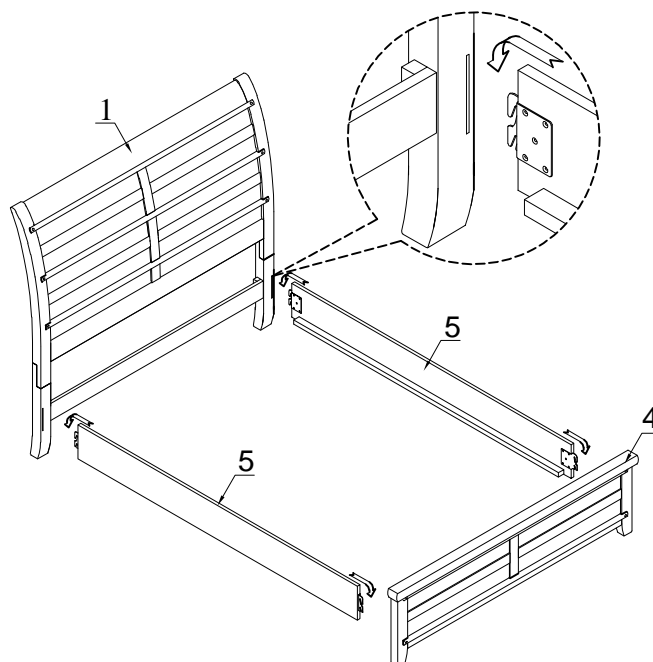

# ASSEMBLY INSTRUCTIONS

## 3

Part #6 x 4pcs

Part #7 x 4pcs

Hardware #H x 8pcs

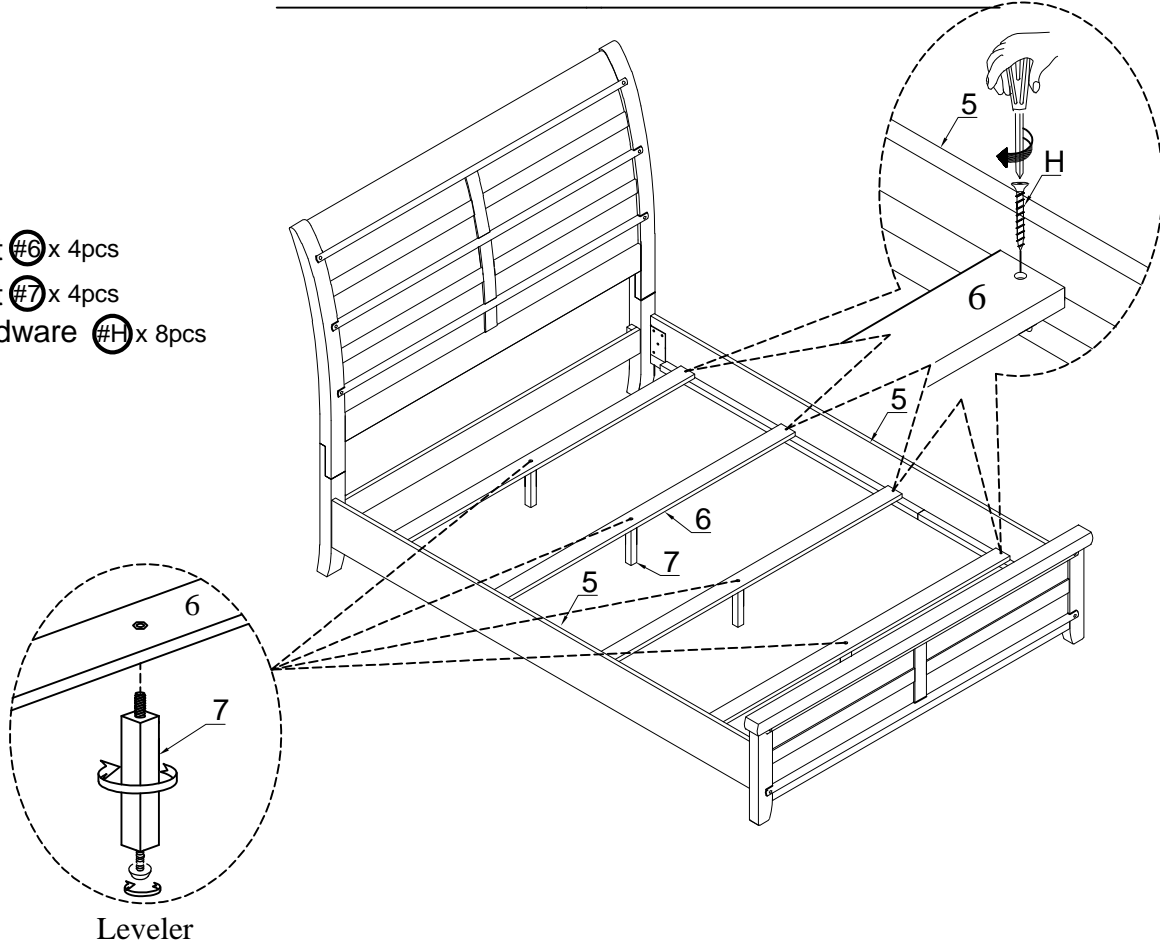

Leveler



**ASSEMBLY COMPLETED**

✓ Please ensure the furniture res on an even and flat surface. If the product wobbles or feels loose, double-check all bolts and/or screws are properly tightened and secured.

✓ **Keep this handy!**  
Please retain this instruction manual and any order-related information for future reference.

# ASSEMBLY INSTRUCTIONS

## Wall Mounting and Fixing



### EXPANSION WALL ANCHOR

Our provided expansion wall anchors are only suitable for masonry walls, such as drywall, plaster or concrete, and are best for holding lightweight items or for anti-tip prevention. If you are unsure of the correct wall anchor to use with the product, please request professional guidance. Liability for product damage or failure due to using the incorrect anchors will fall on the installer.

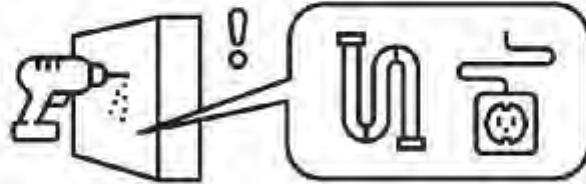

### CHECK BEFORE PROCEEDING

Prior to drilling or hammering, please check for wires or pipes. We recommend using a stud finder to locate a stud, which will offer more appropriate resistance and hold more weight.

## QUICK TIPS

1. If unsure of the proper size, always choose a larger screw and wall anchor.

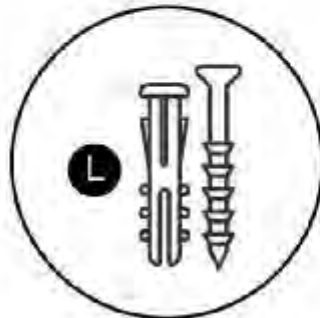

2. Match the drill bit to the wall anchor and hole size.

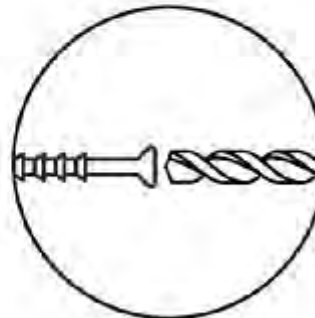

3. Only drill horizontally. Do not force the drill or enlarge the hole for the wall anchor.

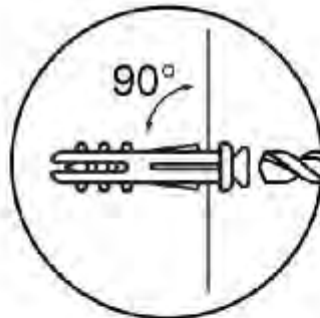

4. Take extra care when drilling into high walls or ceramic tiles. Wall anchors should be a tight fit for the hole. Never use wall anchors in ceilings.

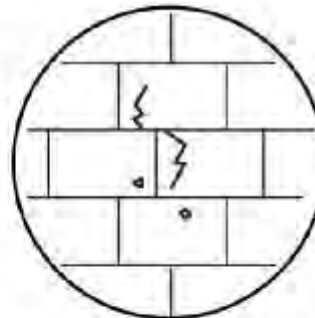

### MAINTENANCE



We recommend a yearly check to see if the wall anchor or screw has loosened. If so, please remove the existing wall anchor and screw, and use a new anchor.