



INSTALLATION MANUAL



NOTICE

IMPORTANT, RETAIN FOR FUTURE REFERENCE: READ CAREFULLY
WICHTIG, FÜR SPÄTERE NACHSCHLAGE AUFBEWAHREN: SORGFÄLTIG LESEN
IMPORTANTE, GUARDAR PARA REFERENCIA FUTURA: LEER ATENTAMENTE
IMPORTANTE, CONSERVARE PER RIFERIMENTI FUTURI: LEGGERE ATTENTAMENTE
IMPORTANT, À CONSERVER POUR RÉFÉRENCE FUTURE : LIRE ATTENTIVEMENT

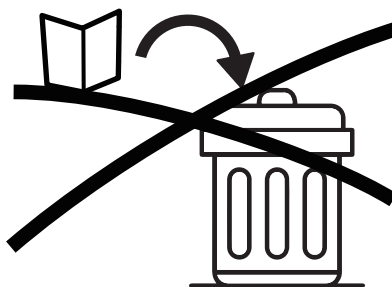
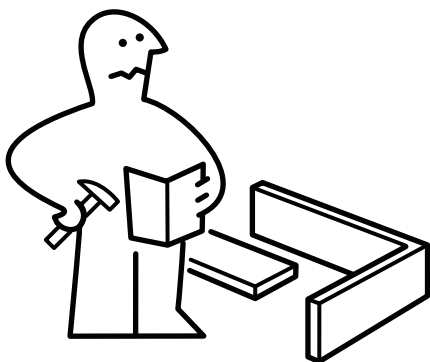

Assemble on a flat, clean and soft surface.

Auf einer flachen, sauberen und weichen Oberfläche zusammenbauen.

Assembler sur une surface plate, propre et douce.

Assemblare su una superficie piatta, pulita e morbida.

Ensamblar sobre una superficie plana, limpia y suave.

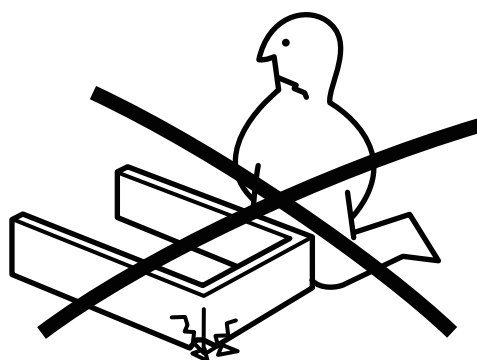
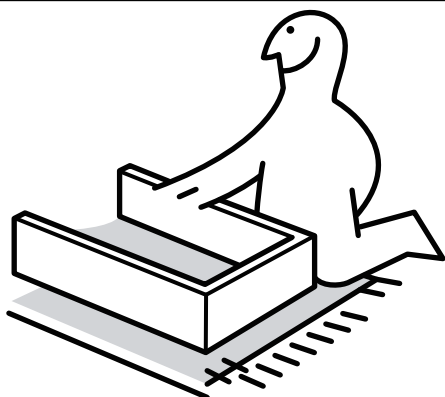

Professional installation is highly recommended.

Eine professionelle Installation wird dringend empfohlen.

Une installation professionnelle est fortement recommandée.

Si raccomanda vivamente l'installazione professionale.

Se recomienda altamente la instalación profesional.



Periodically check that all components are tightly secured.

Überprüfen Sie Regelmäßig, Dass Alle Komponenten Fest Gesichert Sind.

Vérifiez Périodiquement Que Tous Les Composants Sont Bien Fixés.

Controllare Periodicamente Che Tutti I Componenti Siano Ben Fissati.

Verifique Periódicamente Que Todos Los Componentes Estén Bien Asegurados.

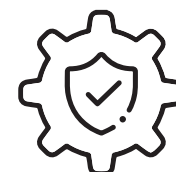

It is recommended that multiple people assemble this product.

Es wird empfohlen, dass mehrere Personen dieses Produkt zusammenbauen.

Il est recommandé que plusieurs personnes assemblent ce produit.

Si raccomanda che più persone assemblino questo prodotto.

Se recomienda que varias personas ensamblen este producto.

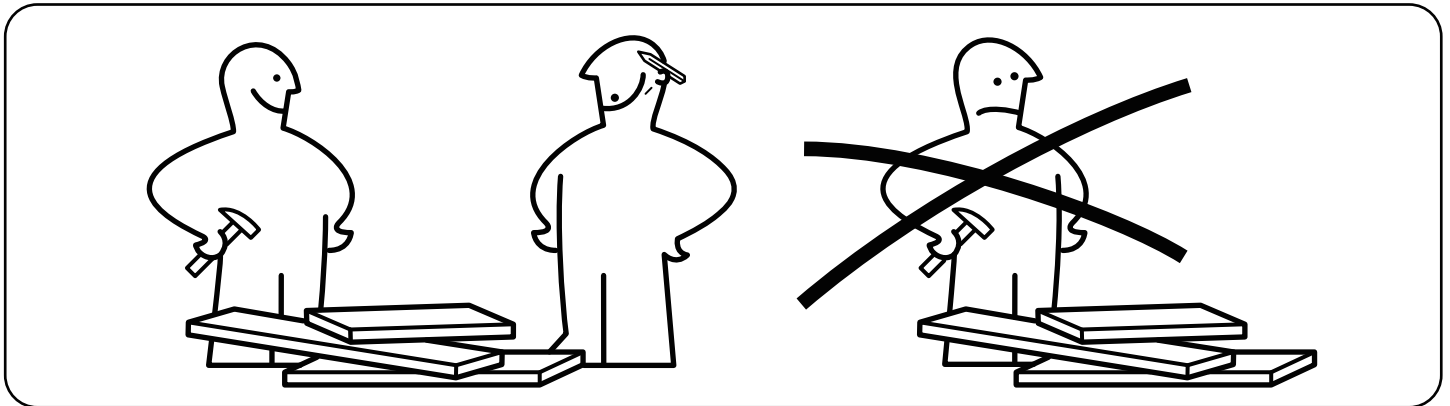

Press And Hold The Drawer Runner Lock And Then Continue To Slide Drawer Runners Apart Before Installation.

Drücken Und Halten Sie Die Schubladenauszugssperre Und Schieben Sie Dann Die Schubladenauszüge Auseinander, Bevor Sie Installieren.

Pressez Et Maintenez Le Verrou Du Coulisseau Du Tiroir, Puis Continuez À Écarter Les Coulisses Du Tiroir Avant L'installation.

Premere E Tenere Premuto Il Blocco Della Guida Del Cassetto, Quindi Continuare A Scorrere Le Guide Del Cassetto Separatamente Prima Dell'installazione.

Presione Y Mantenga Presionado El Bloqueo Del Corredor Del Cajón Y Luego Continúe Deslizando Los Corredores Del Cajón Por Separado Antes De La Instalación.

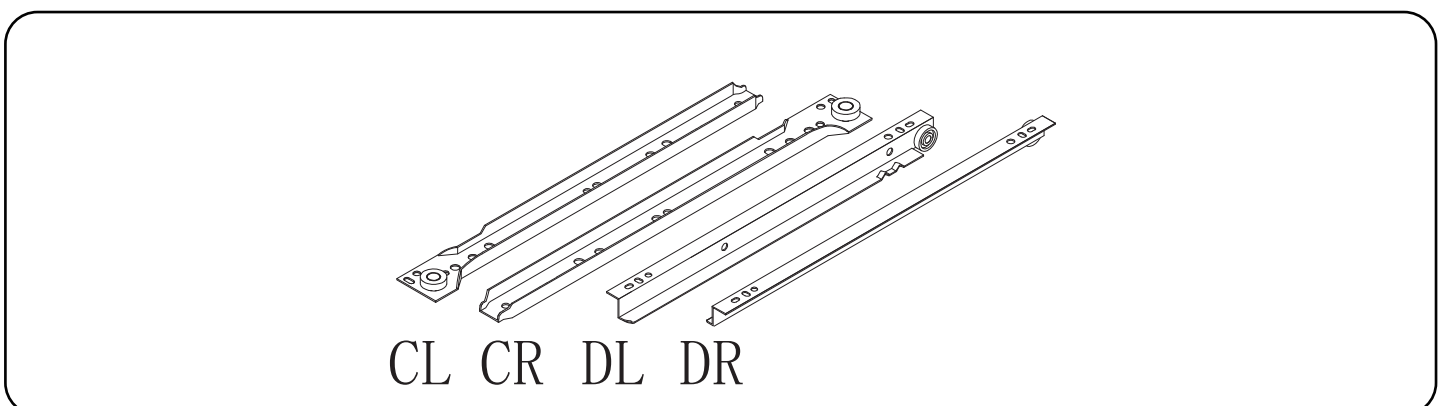

Please have the following auxiliary tools ready:

Bitte halten Sie folgende Hilfswerkzeuge bereit:

Veillez préparer les outils auxiliaires suivants :

Si prega di avere pronti i seguenti strumenti ausiliari:

Por favor, tenga listas las siguientes herramientas auxiliares:

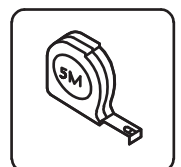
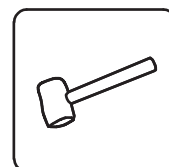

Never let children climb or hang on drawers, doors, or shelves.

Lassen Sie Kinder niemals auf Schubladen, Türen oder Regalen klettern oder hängen.

Ne laissez jamais les enfants grimper ou se suspendre aux tiroirs, portes ou étagères.

Non permettere mai ai bambini di arrampicarsi o appendersi ai cassetti, alle porte o agli scaffali.

Nunca permita que los niños trepen o se cuelguen de los cajones, puertas o estantes.



Serious or fatal crushing injuries can occur from furniture tip-over. Always secure this furniture to the wall using tip-over restraints.

Schwere oder tödliche Quetschverletzungen können durch das Umkippen von Möbeln verursacht werden. Sichern Sie diese Möbel immer mit Kipp-Sicherungen an der Wand.

Des blessures graves ou mortelles par écrasement peuvent survenir en cas de basculement de meubles. Fixez toujours ces meubles au mur à l'aide de dispositifs anti-basculement.

Lesioni gravi o mortali da schiacciamento possono verificarsi a causa del ribaltamento dei mobili. Fissare sempre questi mobili alla parete utilizzando i sistemi di blocco anti-ribaltamento.

Pueden ocurrir lesiones graves o fatales por aplastamiento debido al volcamiento de muebles. Siempre asegure este mueble a la pared utilizando dispositivos anti-vuelco.

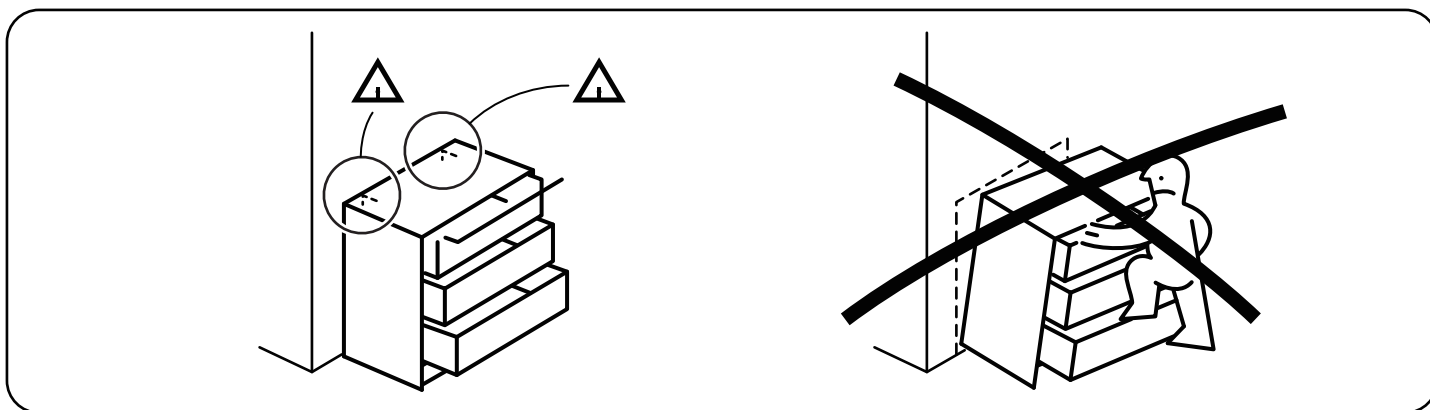

To prevent panel damage during assembly, avoid using power tools and opt for manual tools instead.

Um Schäden an den Paneelen während der Montage zu vermeiden, vermeiden Sie Elektrowerkzeuge und verwenden Sie stattdessen Handwerkzeuge.

Pour éviter d'endommager les panneaux lors de l'assemblage, évitez les outils électriques et utilisez plutôt des outils manuels.

Per prevenire danni ai pannelli durante il montaggio, evita gli utensili elettrici e usa invece utensili manuali.

Para prevenir daños en los paneles durante el montaje, evite herramientas eléctricas y use herramientas manuales en su lugar.

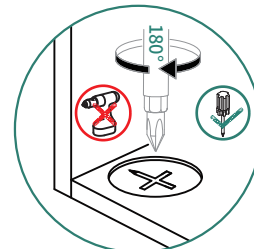
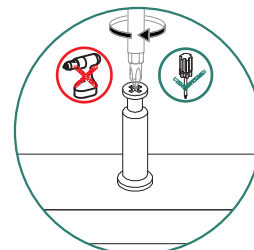

How to adjust the gap between door panels?

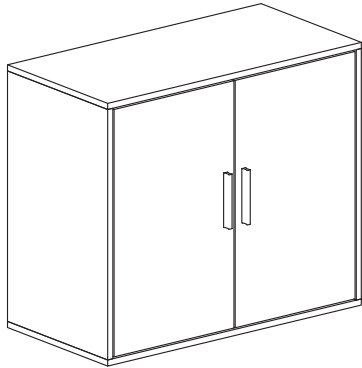

When the space on the four sides is uneven, please refer to the following situations to adjust the hinges

1.

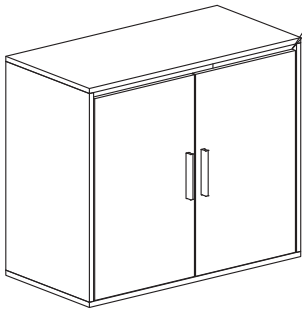

How to adjust the uneven gap between the door panel and the top?

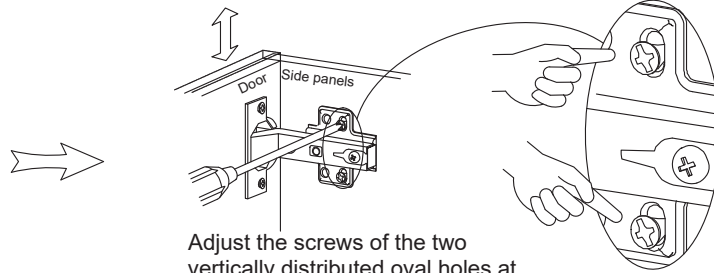

Adjust the screws of the two vertically distributed oval holes at the same time

2.

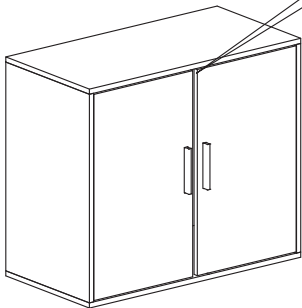

How to adjust the uneven gap between the 2 doors?

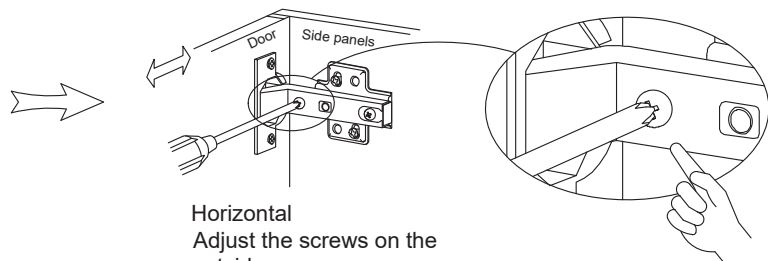

Horizontal
Adjust the screws on the outside

3.

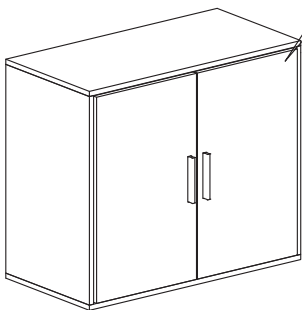



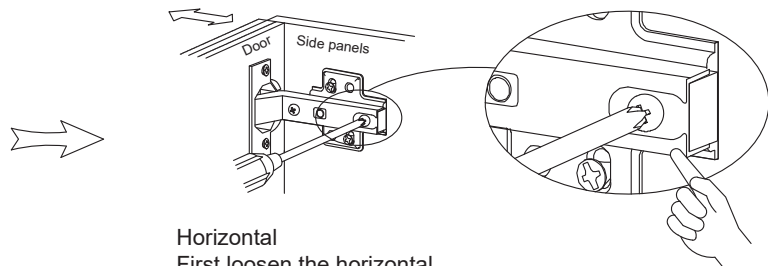



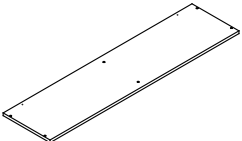
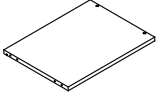
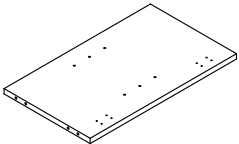
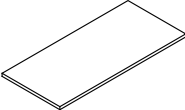
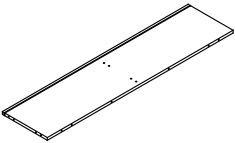
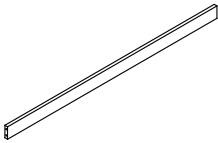
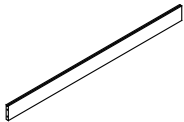
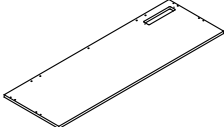
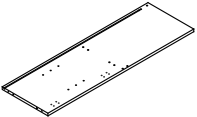
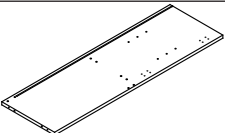
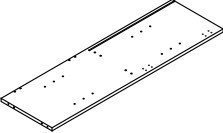
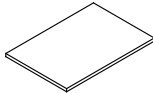
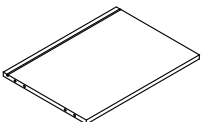
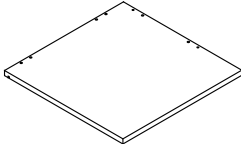
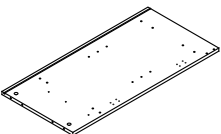
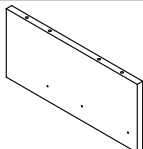
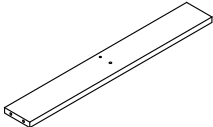
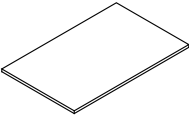
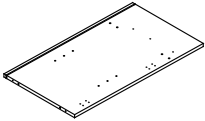
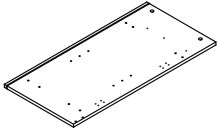
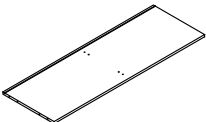
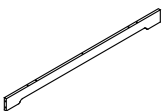

How to adjust the uneven door panel and cabinet?



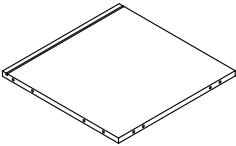
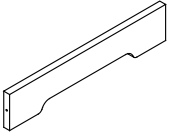
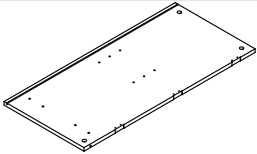
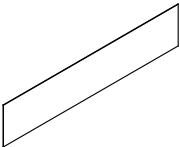

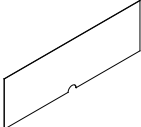
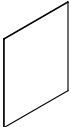
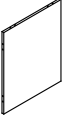
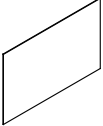
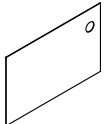

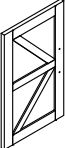
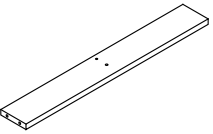
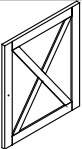

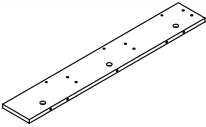
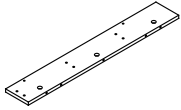
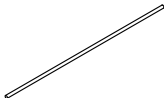
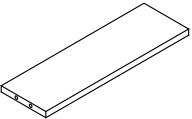
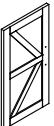

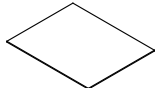
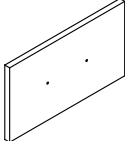
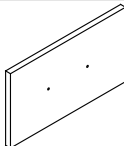
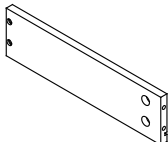
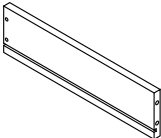
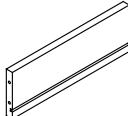
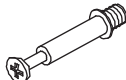





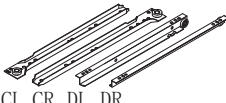



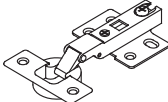

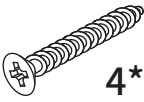

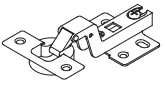
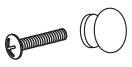
Horizontal
First loosen the horizontal screws, align the door with the cabinet, and then tighten the screws in the inner oval holes.

PARTS

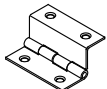
Item no. Nr. N° d'article Articolo No. Artículo No.	Reference Image Referenzbild Image de référence Immagine di riferimento Imagen de referencia	Qty. Menge Qté. Qtà Cant.	Item no. Nr. N° d'article Articolo No. Artículo No.	Reference Image Referenzbild Image de référence Immagine di riferimento Imagen de referencia	Qty. Menge Qté. Qtà Cant.
1		X1	2		X1
3		X1	4		X2
5		X1	6		X1
7		X1	8		X1
9		X1	10		X1
11		X1	12		X3
13		X1	14		X1
15		X1	16		X2
17		X2	18		X2
19		X1	20		X1
21		X1	22		X1

Item no. Nr. N° d'article Articolo No. Artículo No.	Reference Image Referenzbild Image de référence Immagine di riferimento Imagen de referencia	Qty. Menge Qté. Qtà Cant.	Item no. Nr. N° d'article Articolo No. Artículo No.	Reference Image Referenzbild Image de référence Immagine di riferimento Imagen de referencia	Qty. Menge Qté. Qtà Cant.
23		X1	24		X1
25		X1	26		X1
27		X2	28		X1
29		X1	30		X1
31		X1	32		X3
33		X1	34		X2
35		X1	36		X4
37		X2	38		X1
39		X1	40		X1
41		X1	42		X3
43		X3	44		X4

Item no. Nr. N° d'article Articolo No. Artículo No.	Reference Image Referenzbild Image de référence Immagine di riferimento Imagen de referencia	Qty. Menge Qté. Qtà Cant.	Item no. Nr. N° d'article Articolo No. Artículo No.	Reference Image Referenzbild Image de référence Immagine di riferimento Imagen de referencia	Qty. Menge Qté. Qtà Cant.
45		X4	46		X2
47		X2	48		X4
49		X4	50		X4
A		X101+5	B		X101+5
C	 8*30MM	X86+4	D	 4*40MM	X20+2
E	 3.5*12MM	X88+4	F		X42+2
G	 CL CR DL DR	X4	H		X5
I	 3*16MM	X52+3	J	 4*14MM	X108+6
K		X28+2	L		X2
M	 4*12MM	X4	N	 4*35MM	X16+1

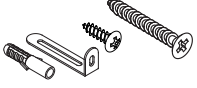
Item no. Nr. N° d'article Articolo No. Artículo No.	Reference Image Referenzbild Image de référence Immagine di riferimento Imagen de referencia		Item no. Nr. N° d'article Articolo No. Artículo No.	Reference Image Referenzbild Image de référence Immagine di riferimento Imagen de referencia	
O		X16	P		X2
Q		X12	R		X1
S		X5	T		X3
U		X1	V		X8
W		X1	X		X1
Y		X4	Z		X2

ASSEMBLY

1

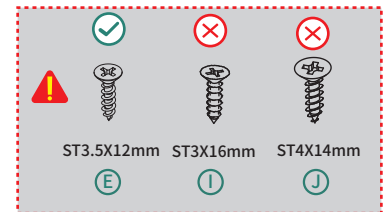
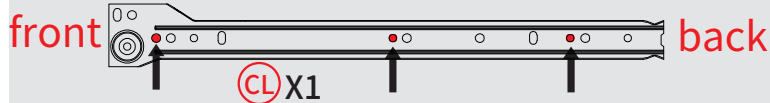
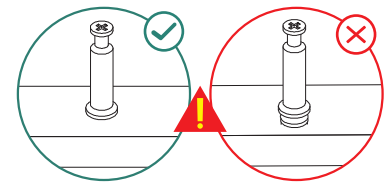
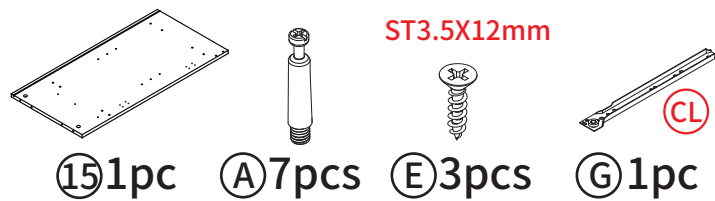

Align the screws with the center of the mounting hole of the guide rail.
 Richten Sie die Schrauben mit der Mitte des Montagelochs der Führungsschiene aus.
 Alignez les vis avec le centre du trou de montage du rail de guidage.
 Allineare le viti con il centro del foro di montaggio della guida.
 Alinee los tornillos con el centro del orificio de montaje de la guía.

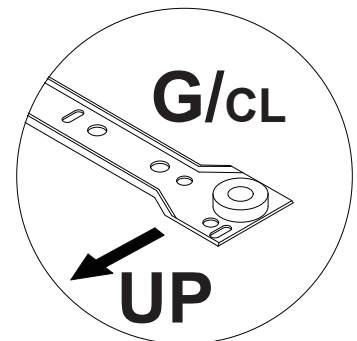
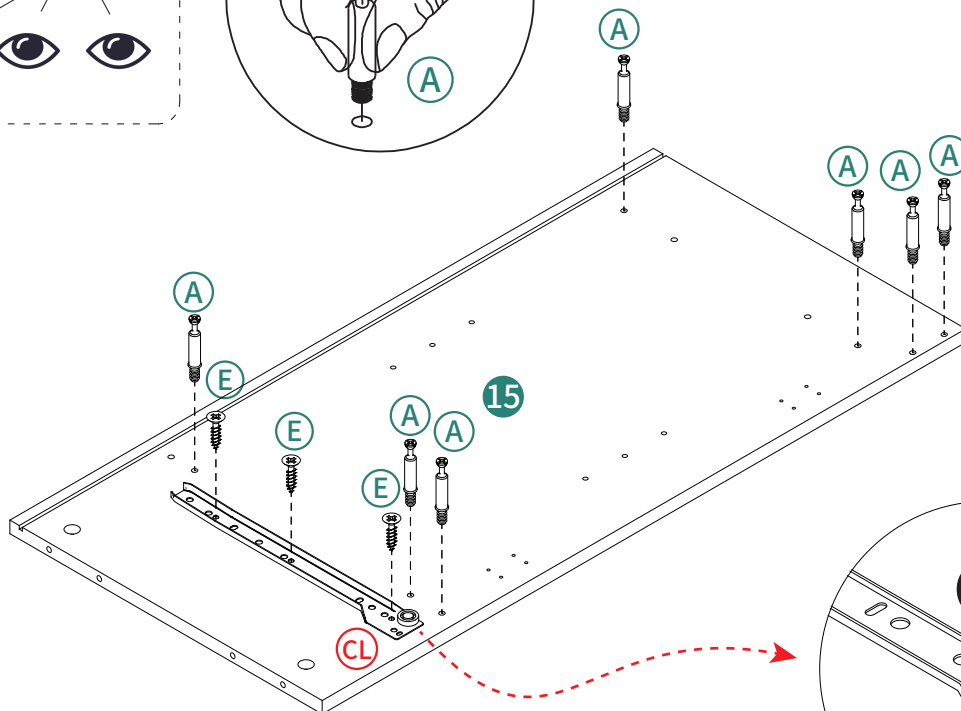
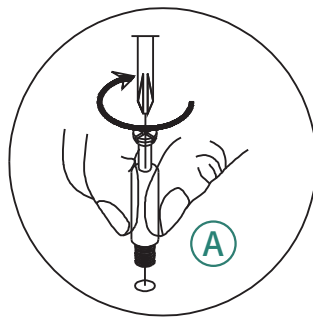
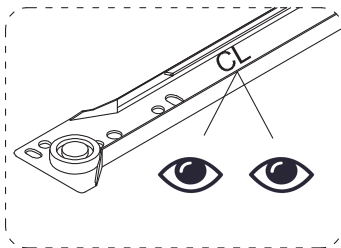

2

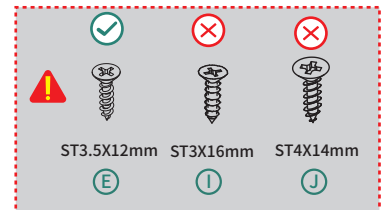
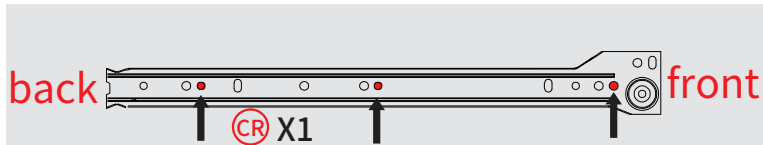
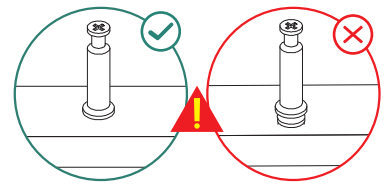
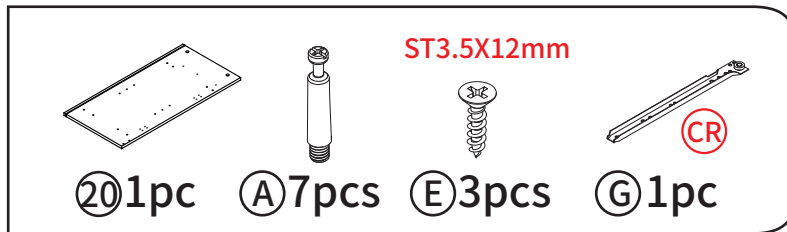

Align the screws with the center of the mounting hole of the guide rail.
Richten Sie die Schrauben mit der Mitte des Montagelochs der Führungsschiene aus.
Alignez les vis avec le centre du trou de montage du rail de guidage.
Allineare le viti con il centro del foro di montaggio della guida.
Alinee los tornillos con el centro del orificio de montaje de la guía.

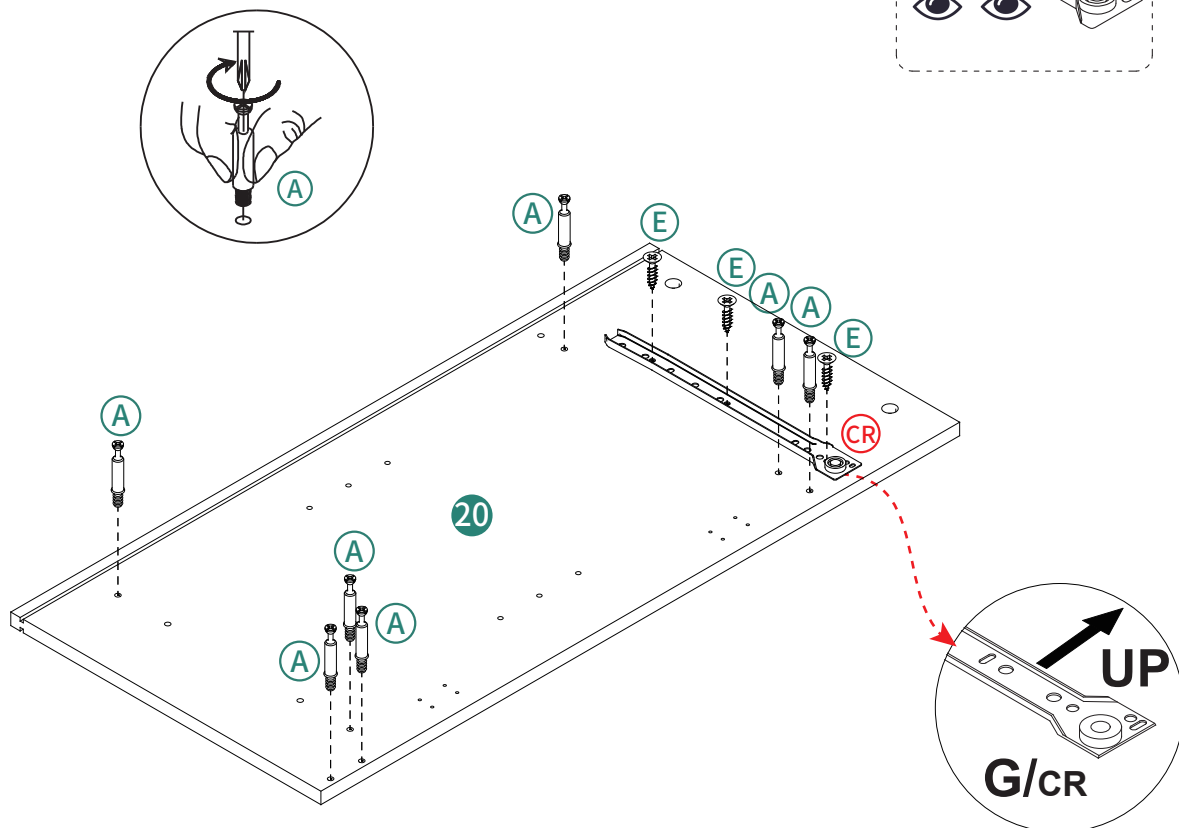
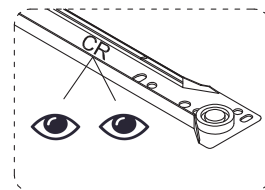

3

ST3.5X12mm

①9 1pc ②A 6pcs ③E 6pcs ④G 1pc 1pc

CR CL

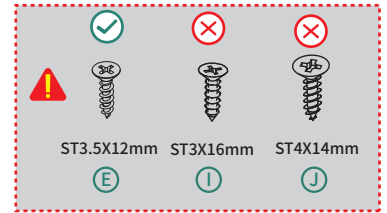
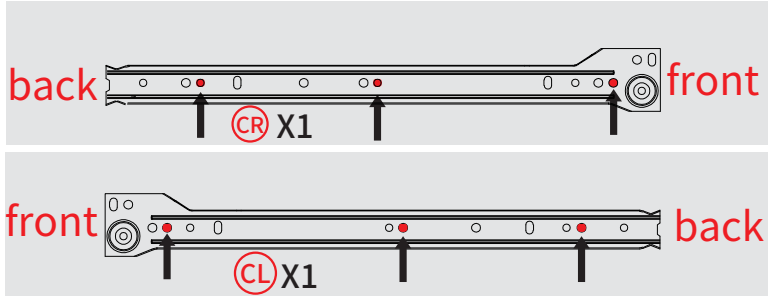
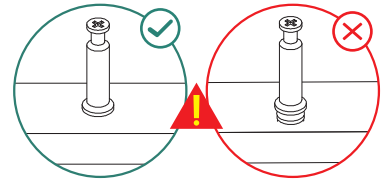

Align the screws with the center of the mounting hole of the guide rail.
 Richten Sie die Schrauben mit der Mitte des Montagelochs der Führungsschiene aus.
 Alignez les vis avec le centre du trou de montage du rail de guidage.
 Allineare le viti con il centro del foro di montaggio della guida.
 Alinee los tornillos con el centro del orificio de montaje de la guía.

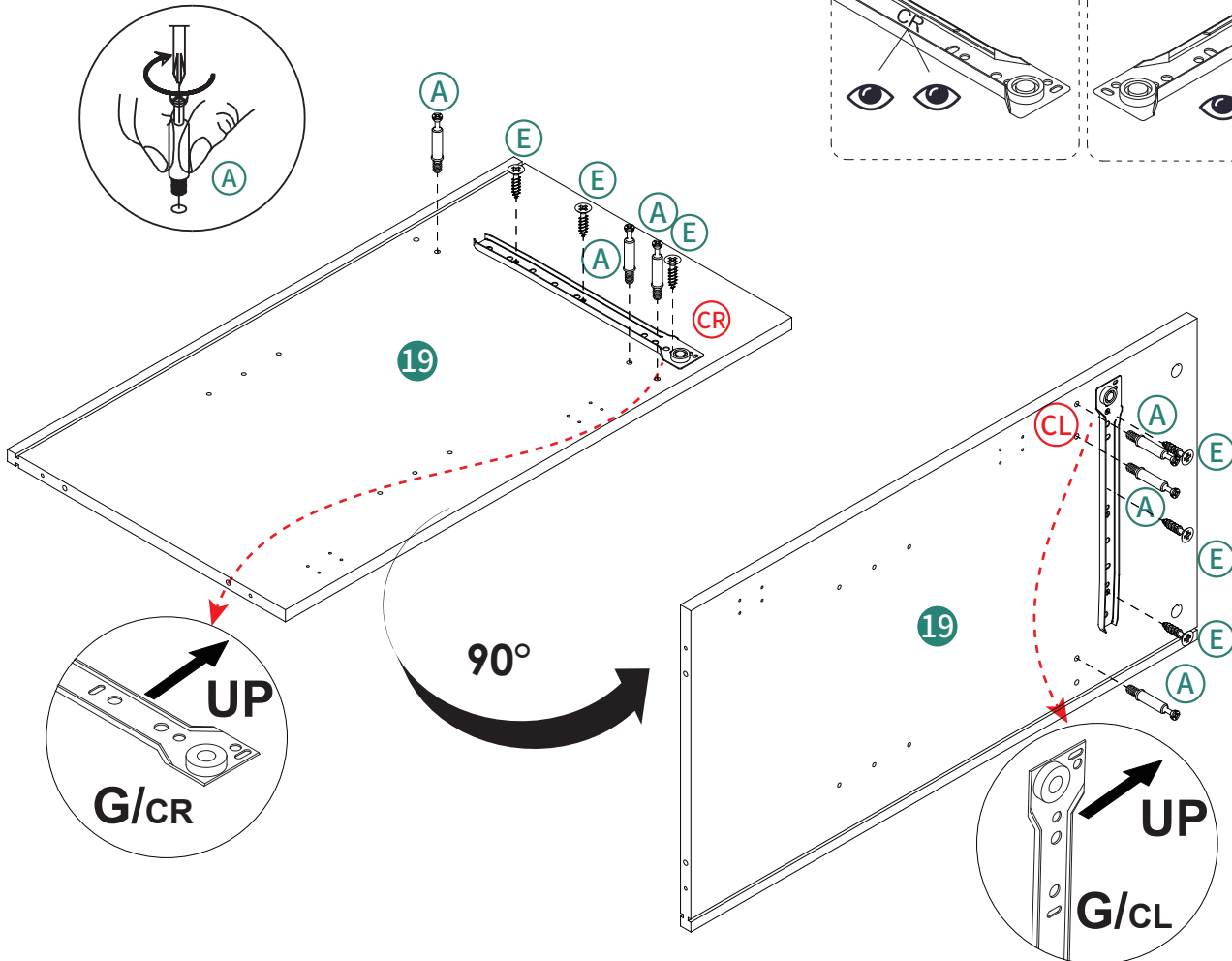
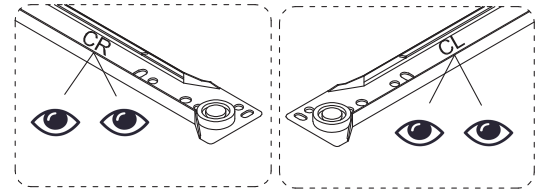

4

X2

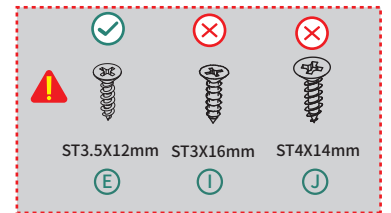
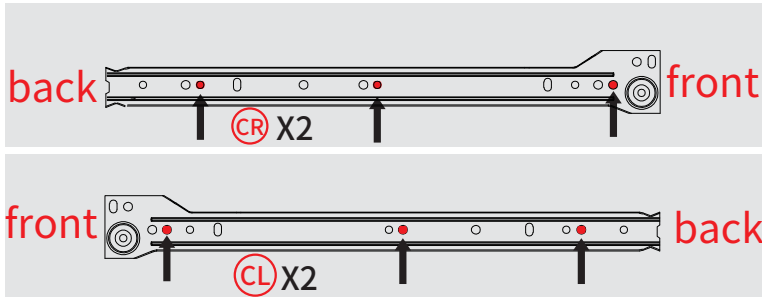
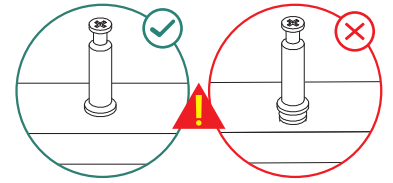
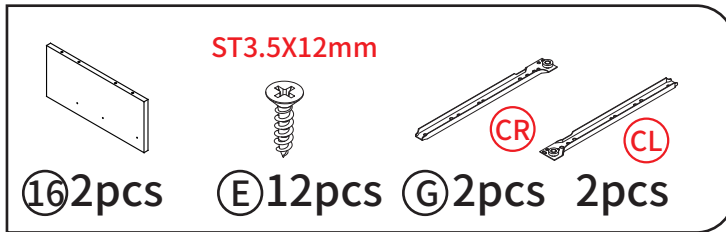

Align the screws with the center of the mounting hole of the guide rail.
Richten Sie die Schrauben mit der Mitte des Montagelochs der Führungsschiene aus.
Alignez les vis avec le centre du trou de montage du rail de guidage.
Allineare le viti con il centro del foro di montaggio della guida.

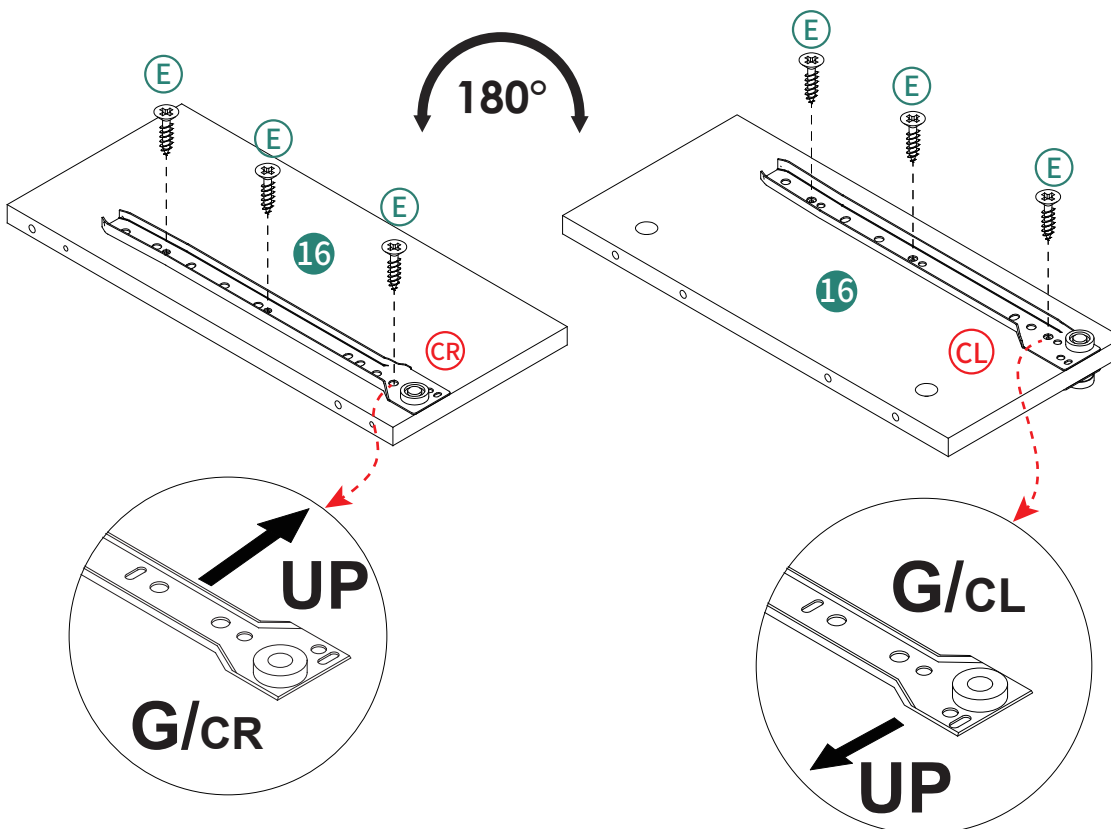
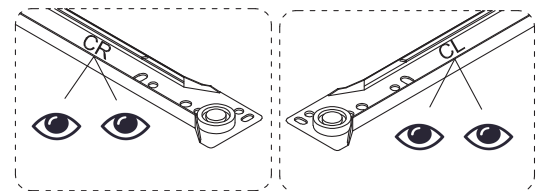

5

- 
21 1pc
- 
22 1pc
- 
C 2pcs
- 
E 12pcs
- 
H 3pcs
- 
M 4pcs
- 
X 1pc

ST8X30mm ST3.5X12mm

ST4X12mm

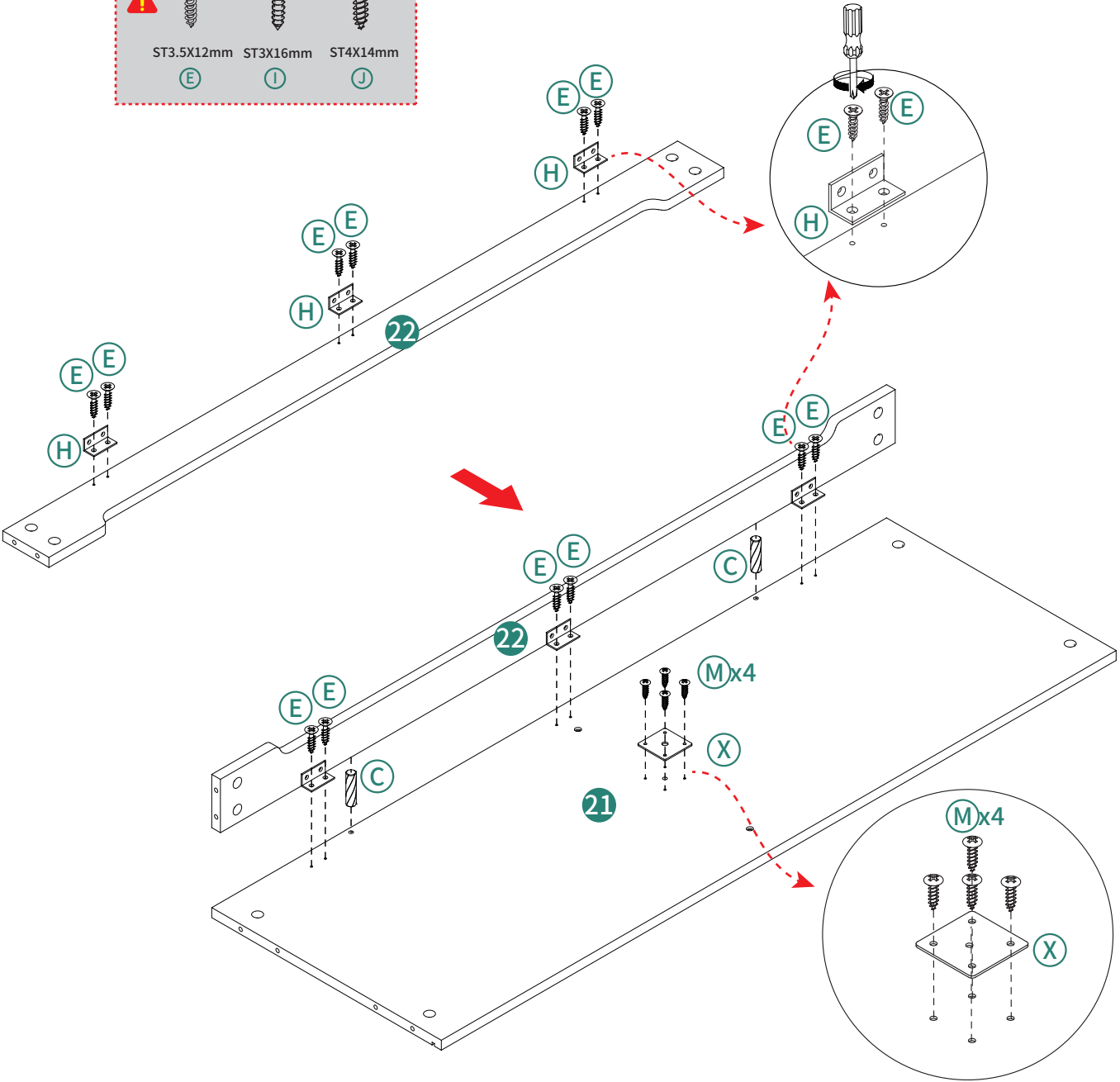
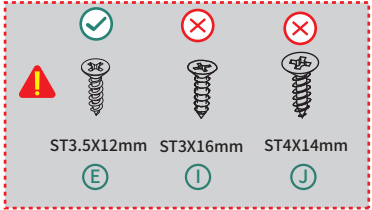

6

ST8X30mm ST4X40mm



②31pc ③C2pcs ④D2pcs

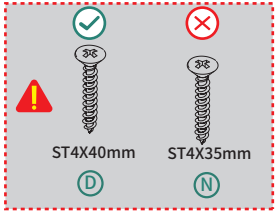

ST4X40mm ST4X35mm

④D ④N

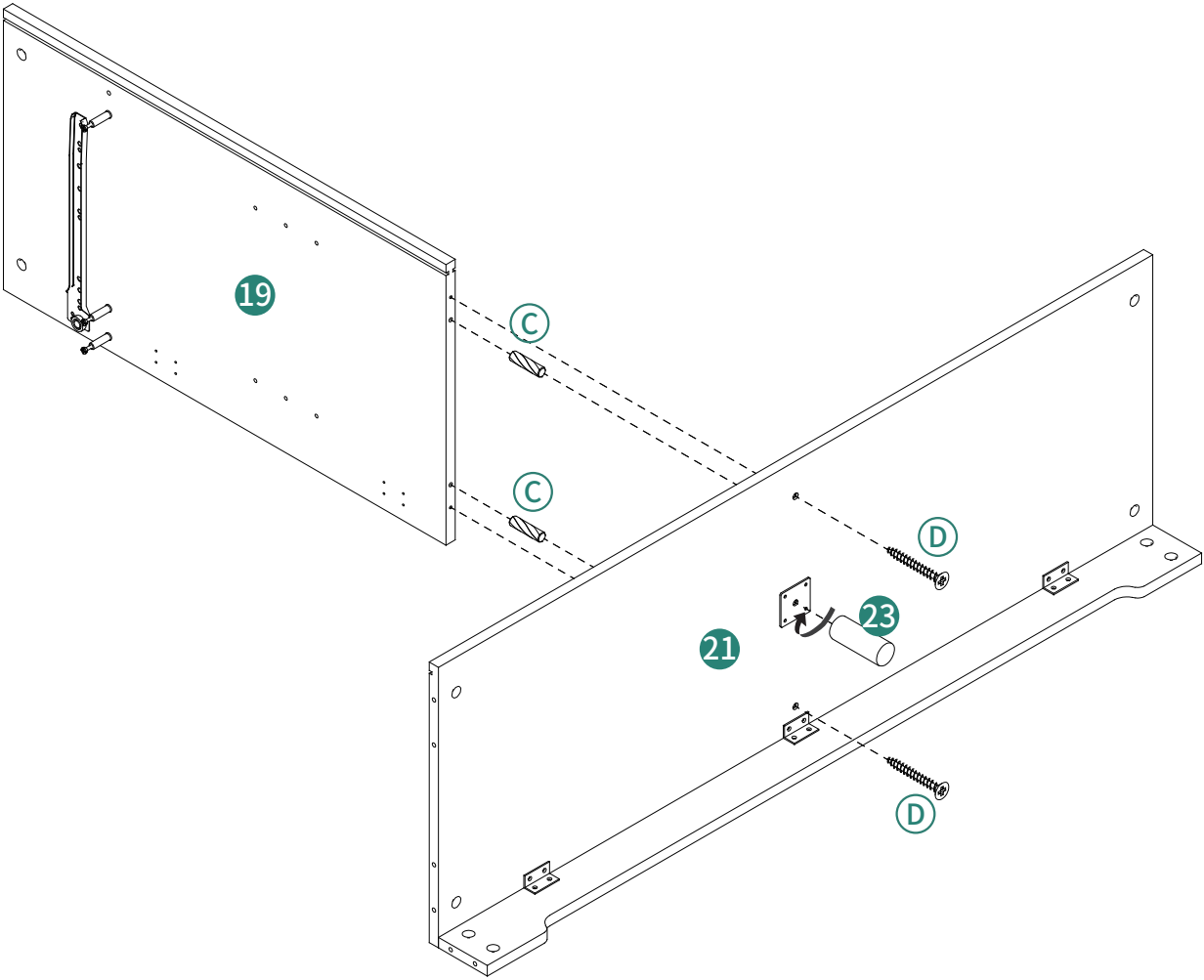

7

X2

①72pcs	③72pcs	①4pcs	⑤2pcs	④4pcs	④4pcs

⑤	①	⑥

④	④

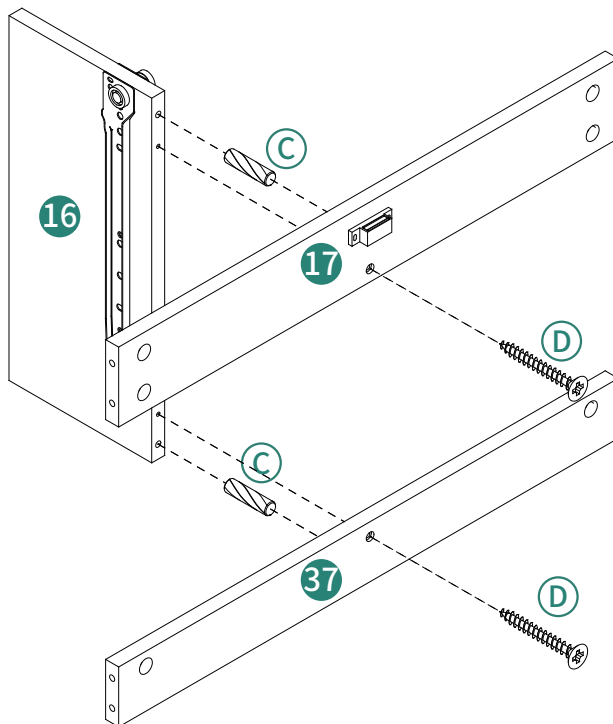
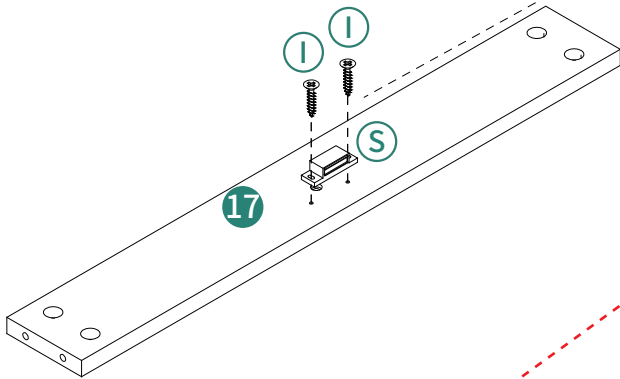
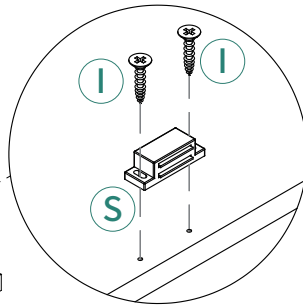

1

2

8

ST8X30mm
Ⓑ6pcs Ⓒ2pcs

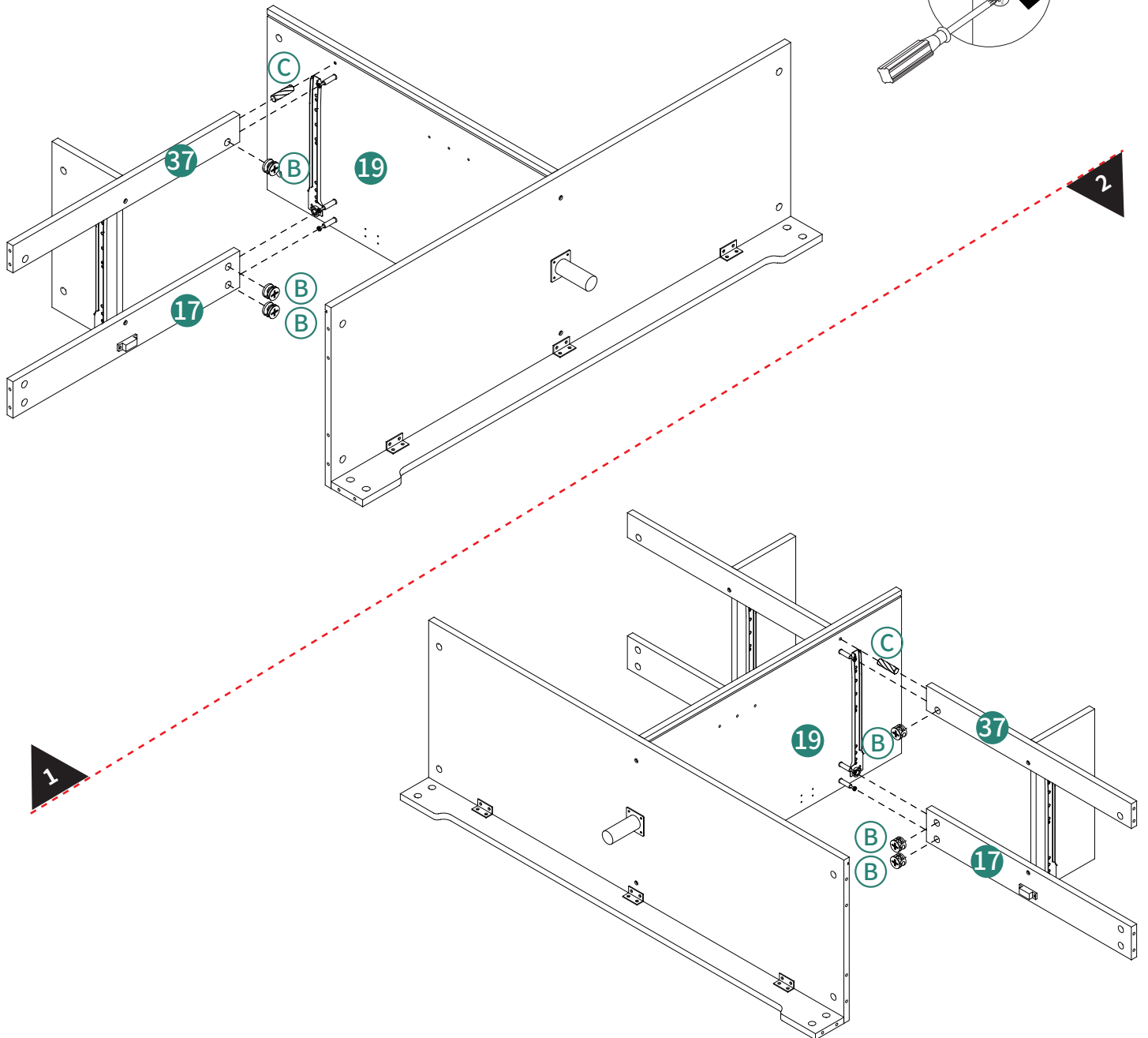
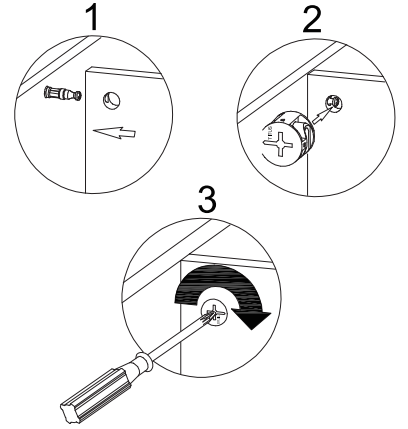

9

ST8X30mm

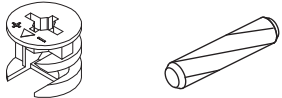

Ⓑ 7pcs **Ⓒ 3pcs**

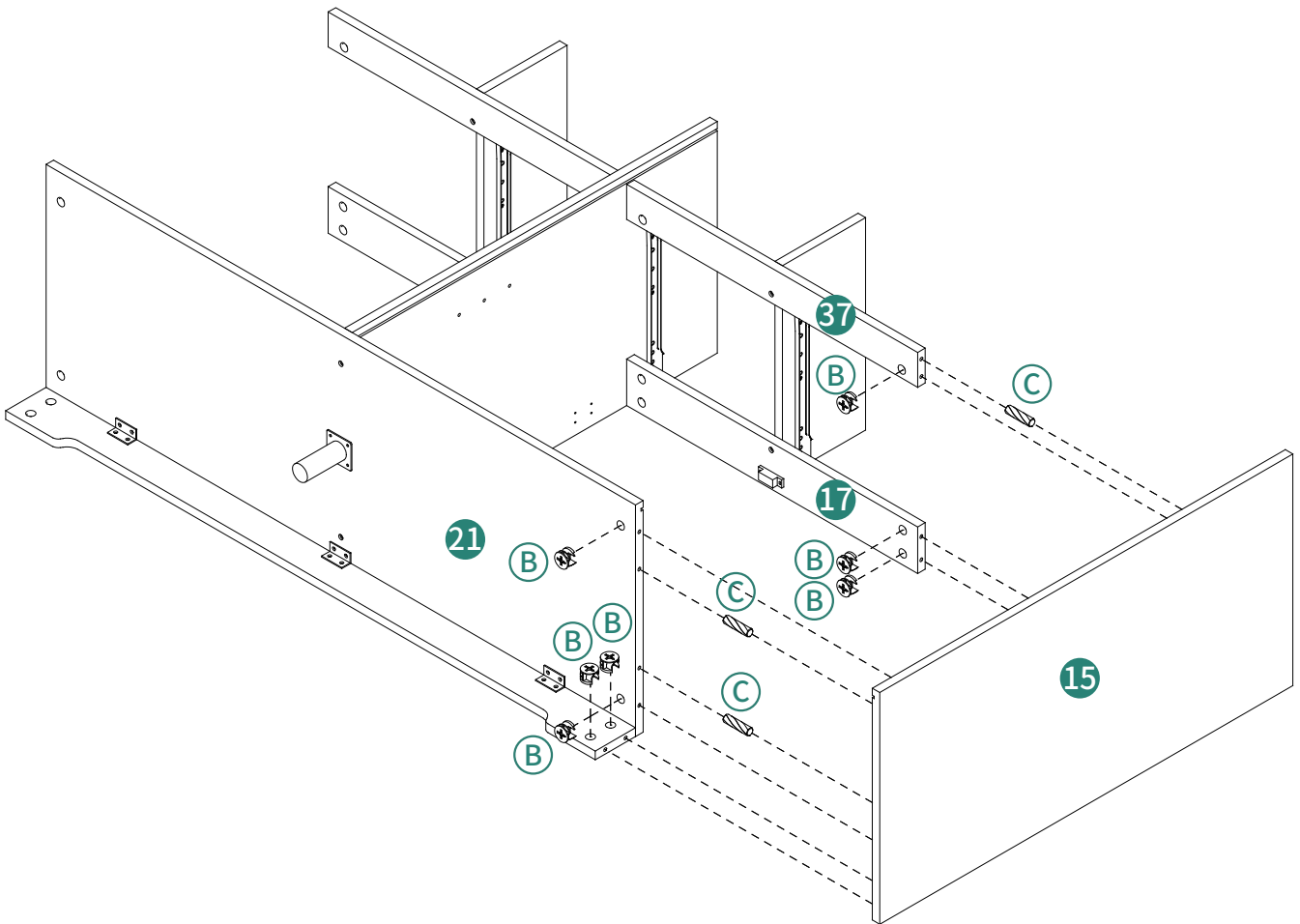
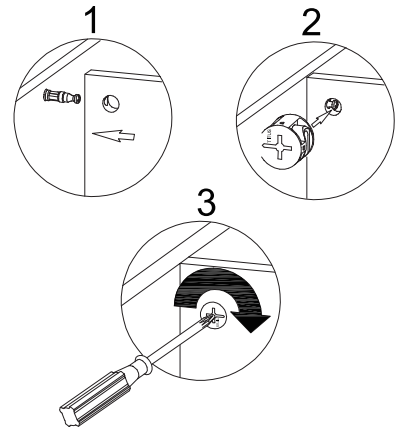

10

ST8X30mm



Ⓑ7pcs Ⓒ3pcs

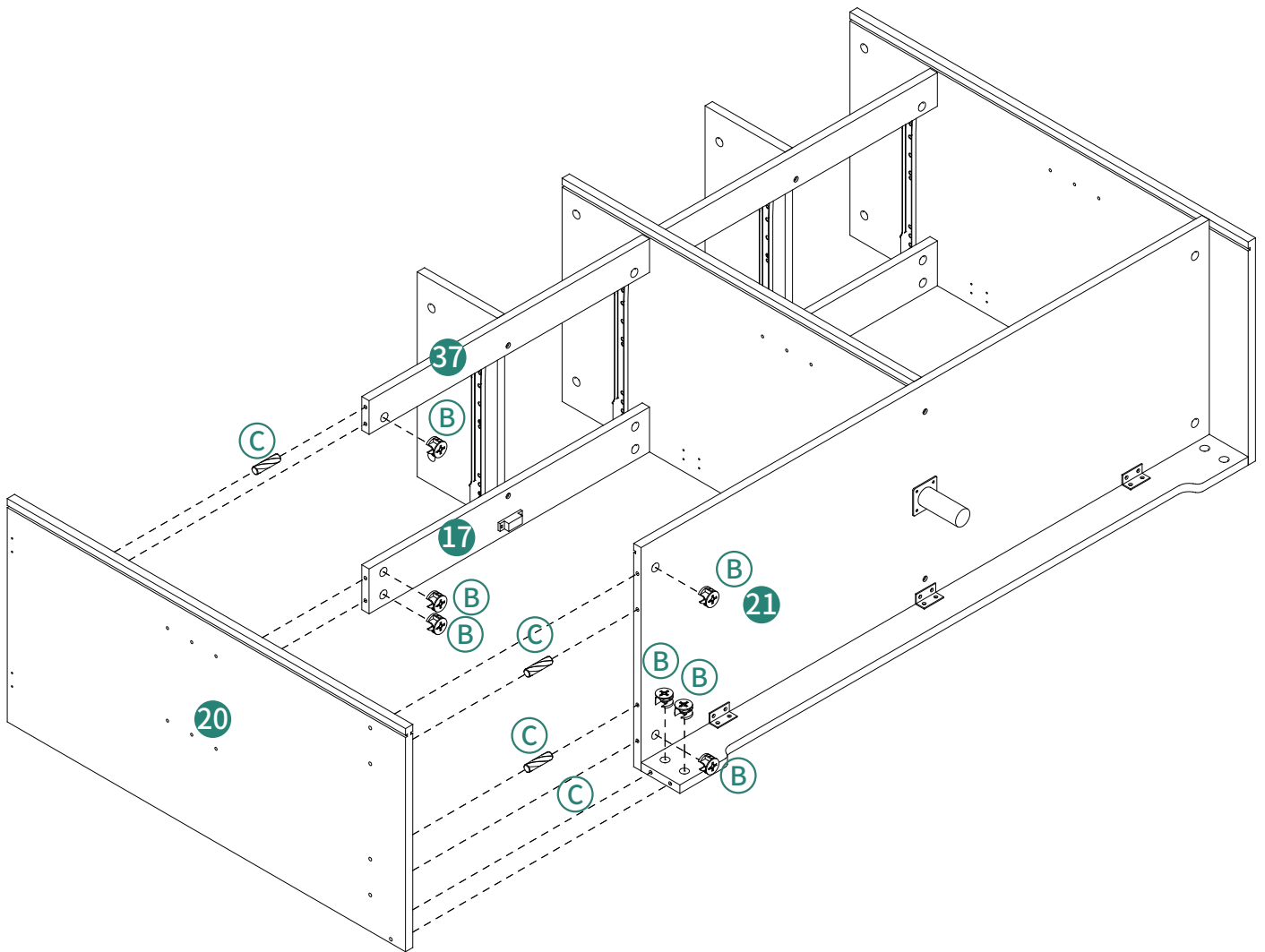
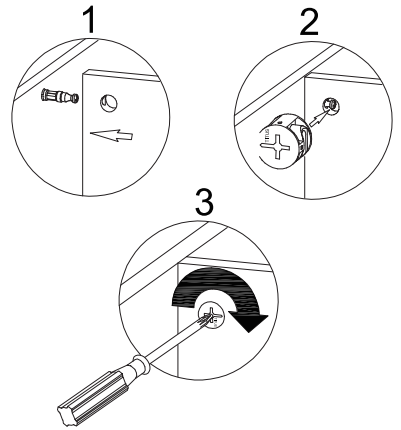

11

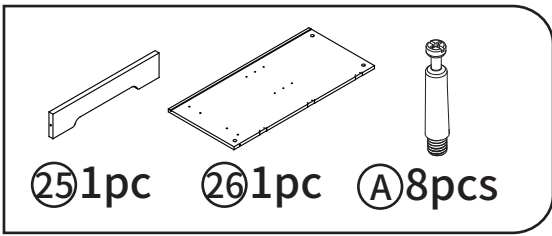

②5 1pc ②6 1pc ①A 8pcs

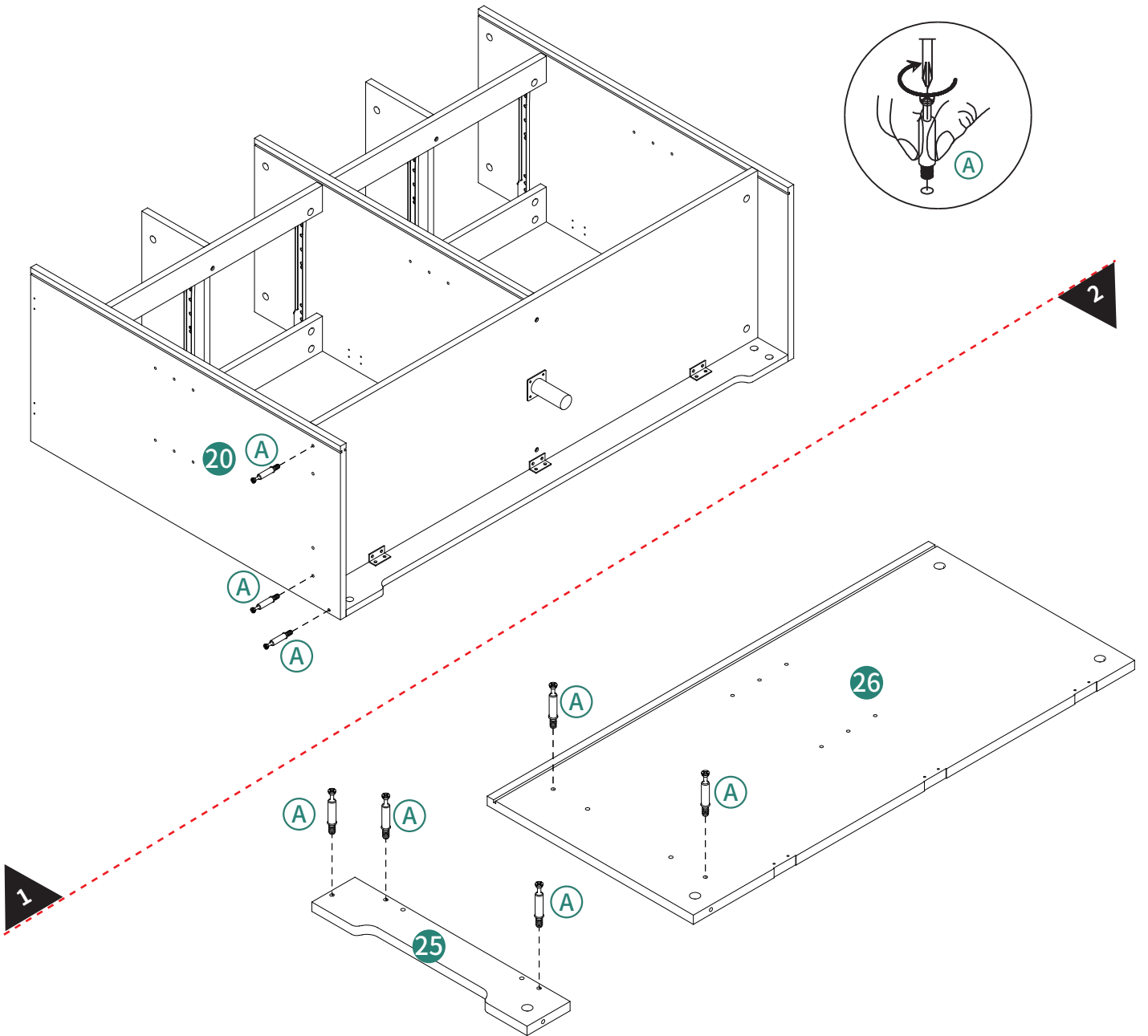
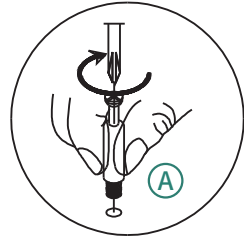
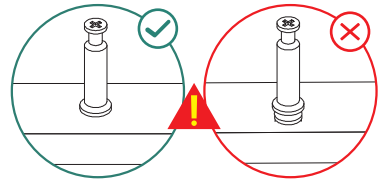

12

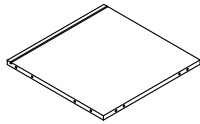

24 1pc

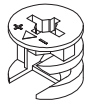

B 5pcs

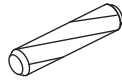

ST8X30mm

C 4pcs

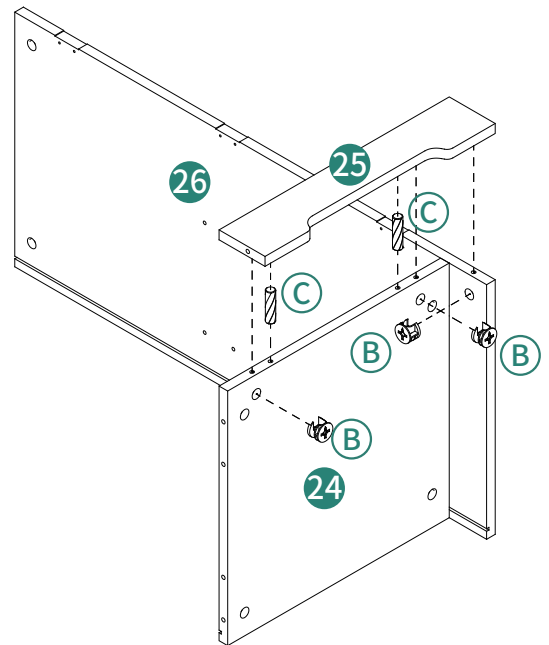
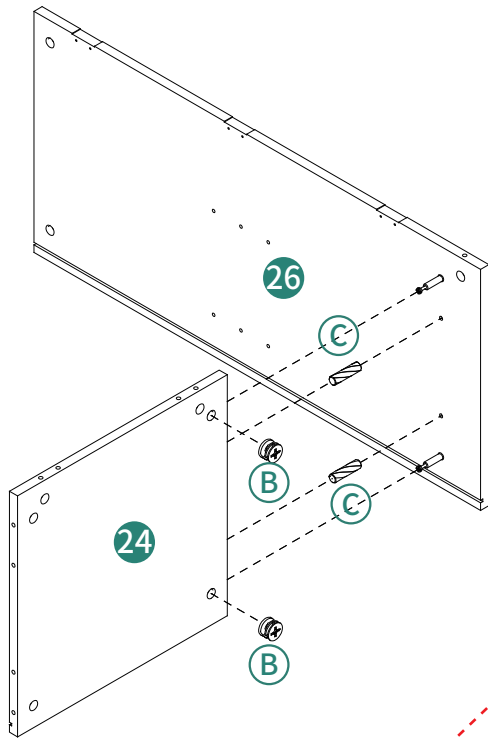
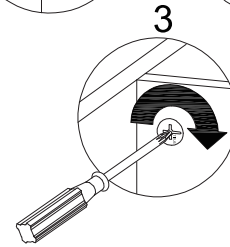
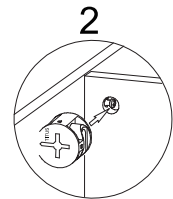
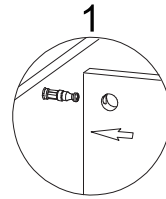

13

ST8X30mm



Ⓑ 3pcs Ⓒ 2pcs

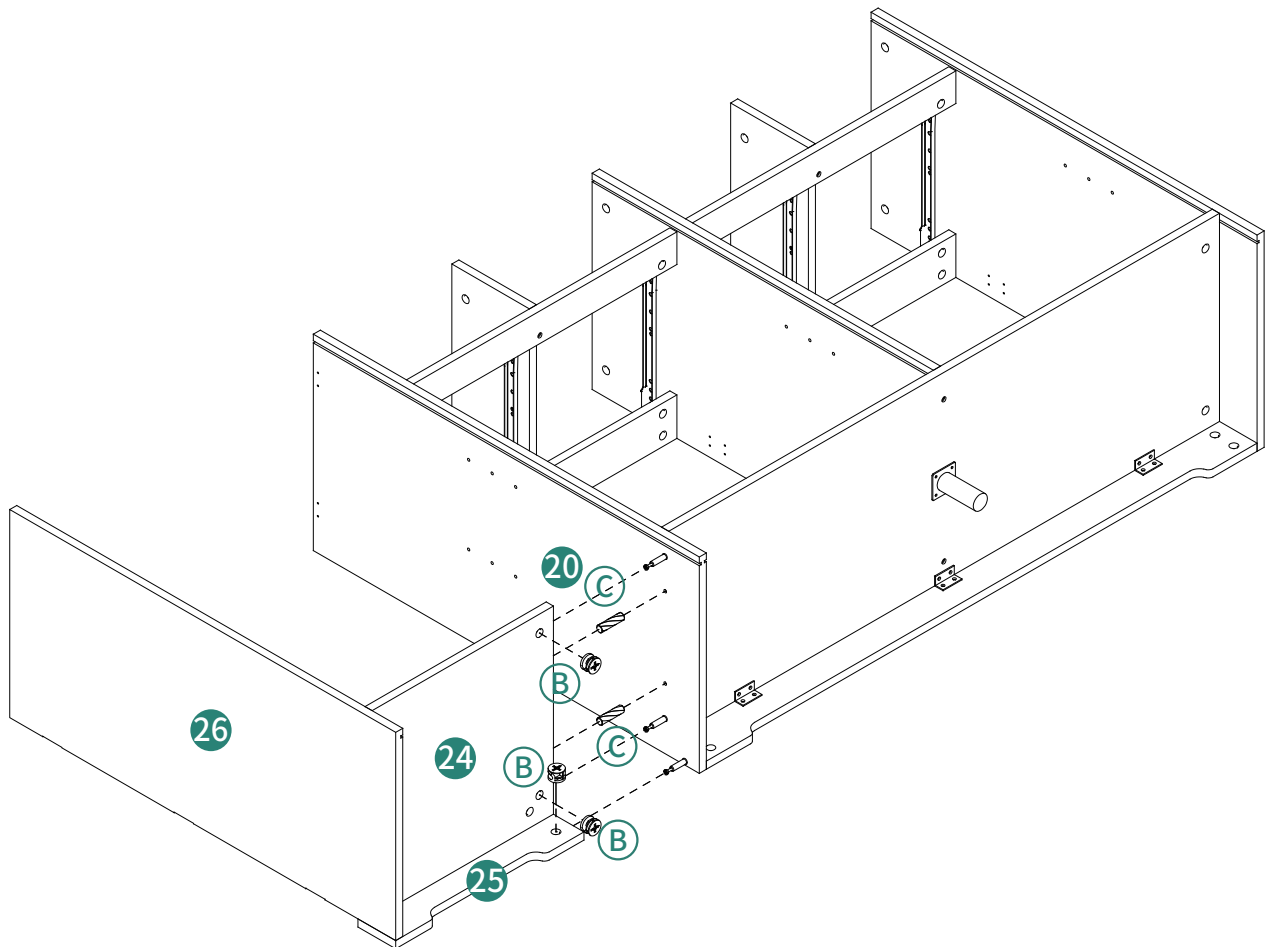
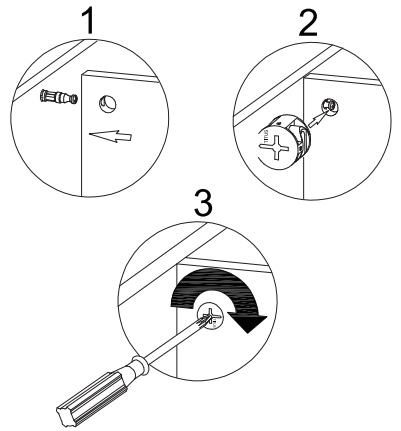

14

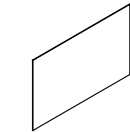

③2 3pcs

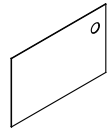

③3 1pc



③4 2pcs

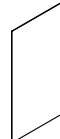

③5 1pc

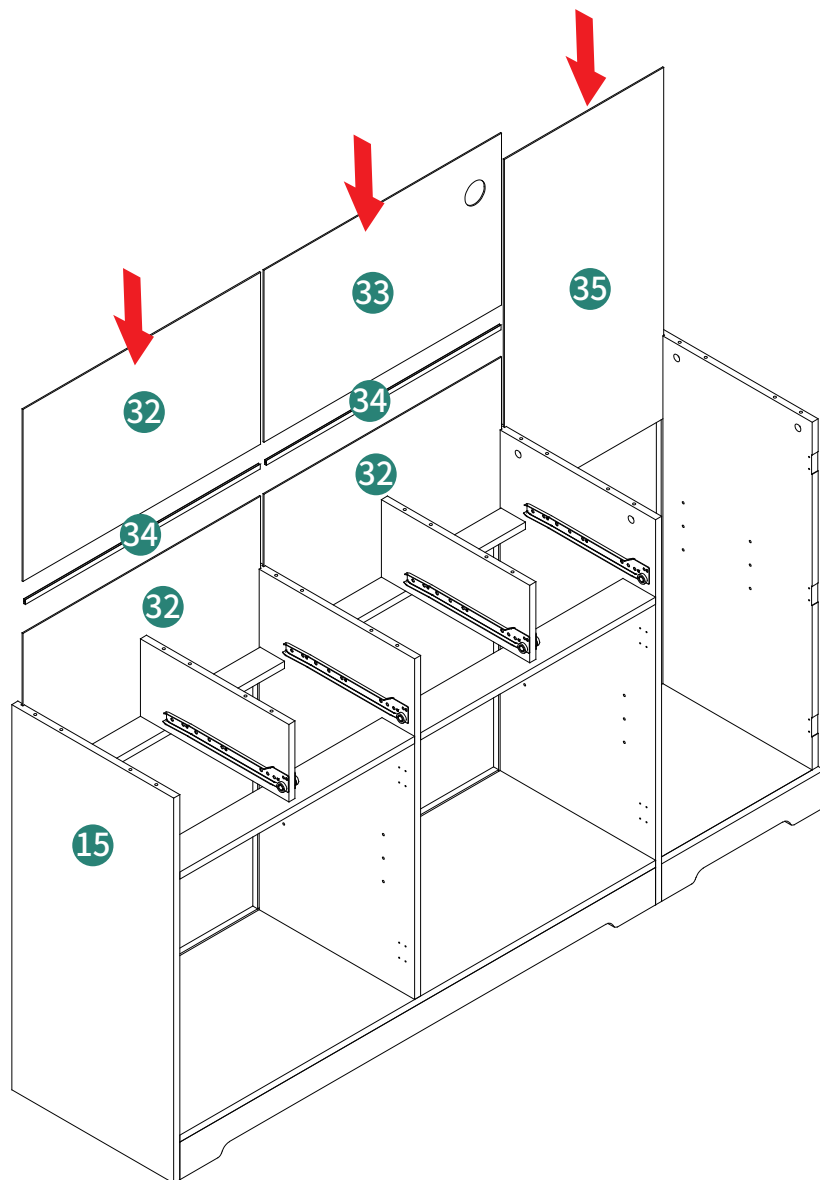

15

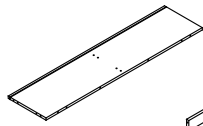

⑤1pc

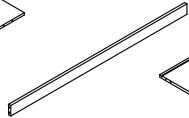

⑥1pc

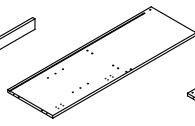

⑨1pc

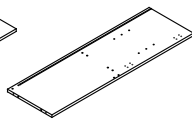

⑩1pc



Ⓐ14pcs

ST3.5X12mm



Ⓔ4pcs



Ⓨ4pcs

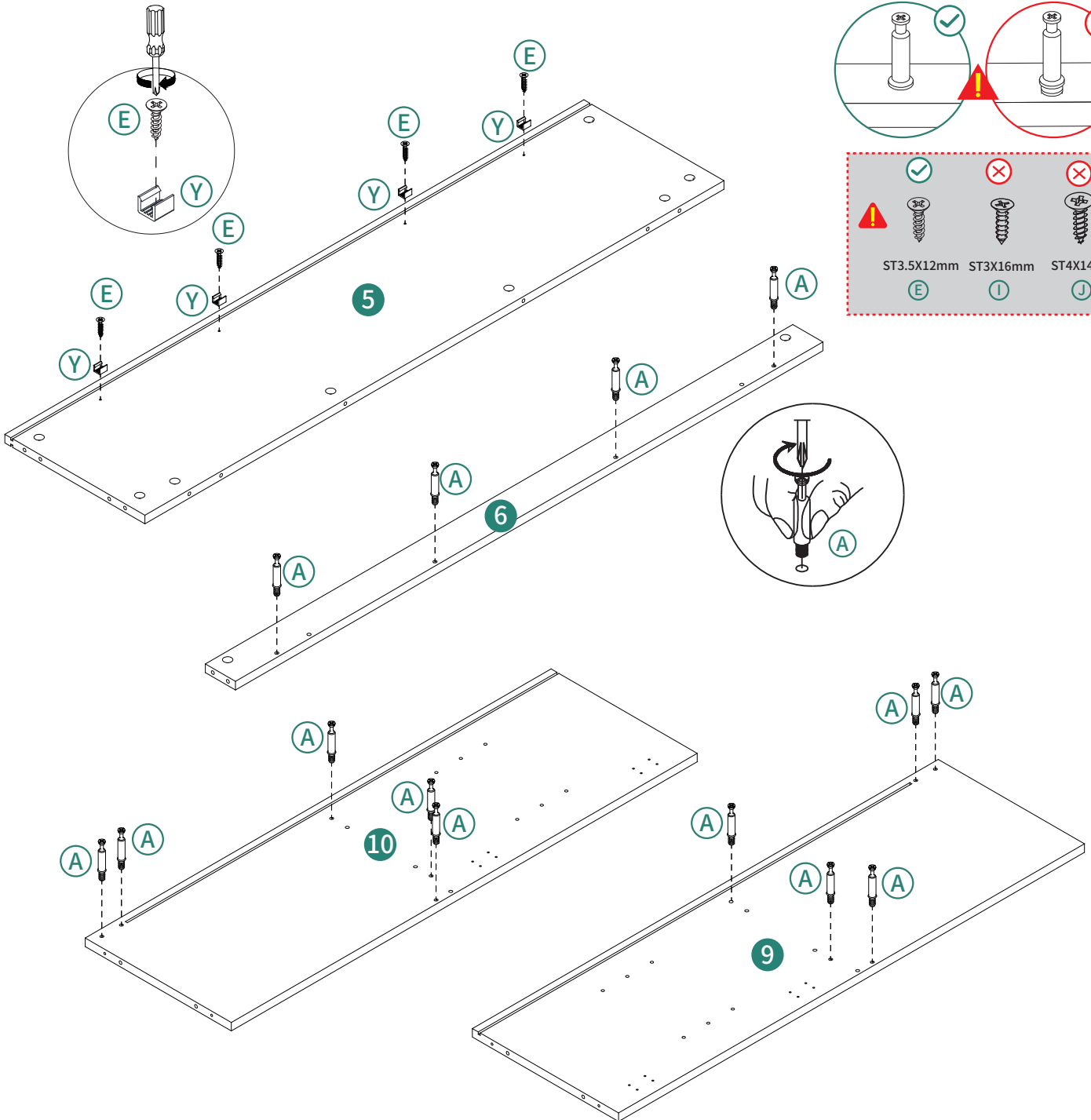

16

ST8X30mm

- (A) 2pcs
- (B) 4pcs
- (C) 2pcs

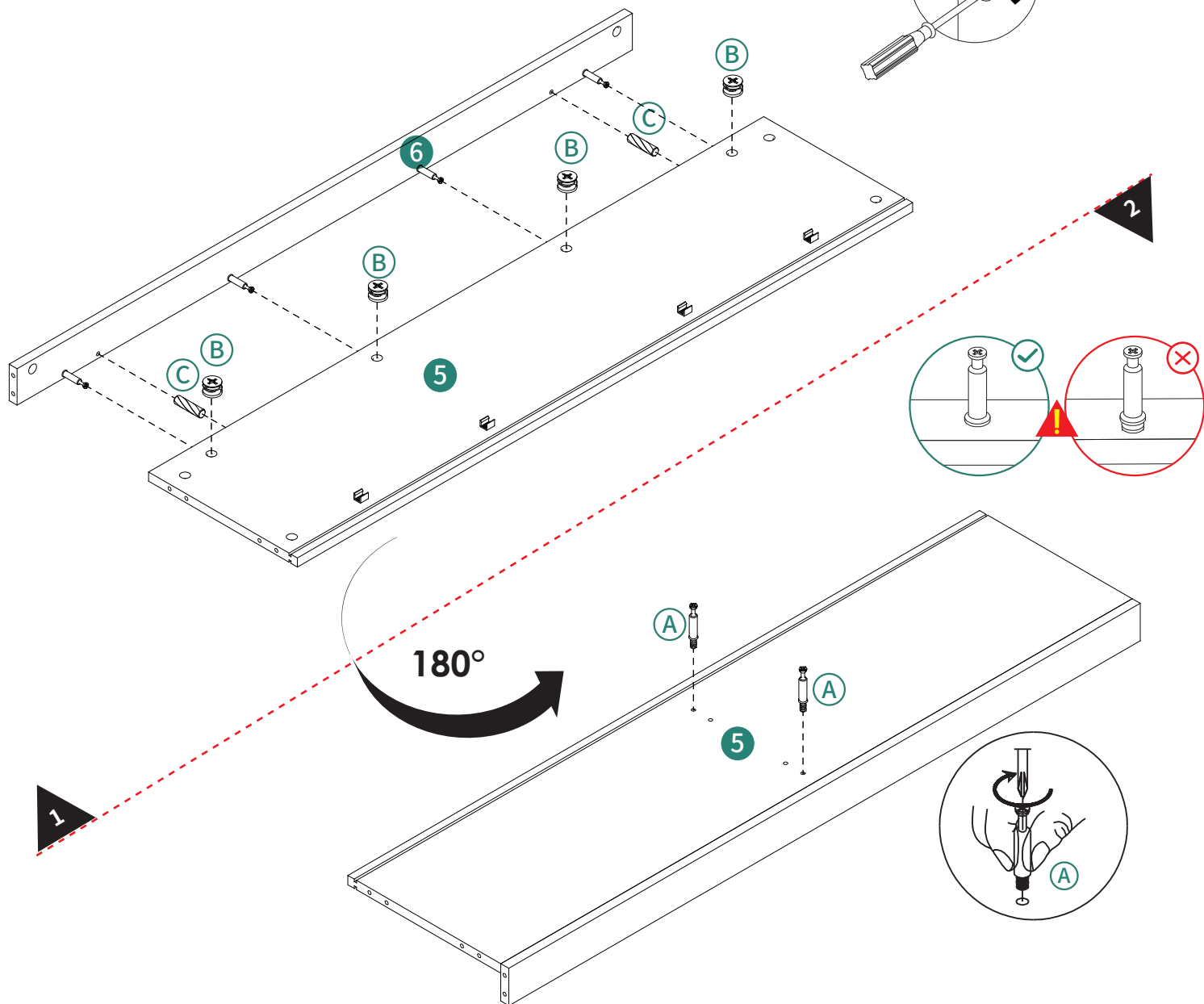
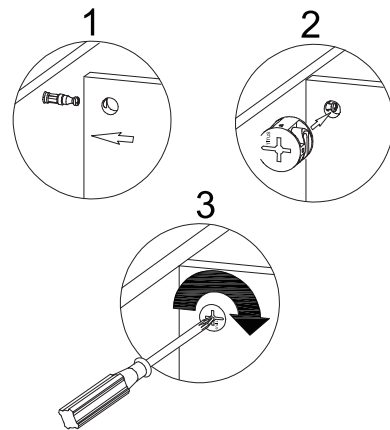

17

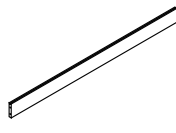

⑦ 1pc

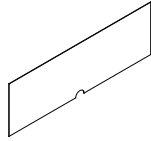

②⑨ 1pc



Ⓑ 5pcs

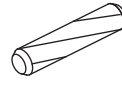

ST8X30mm

Ⓒ 3pcs

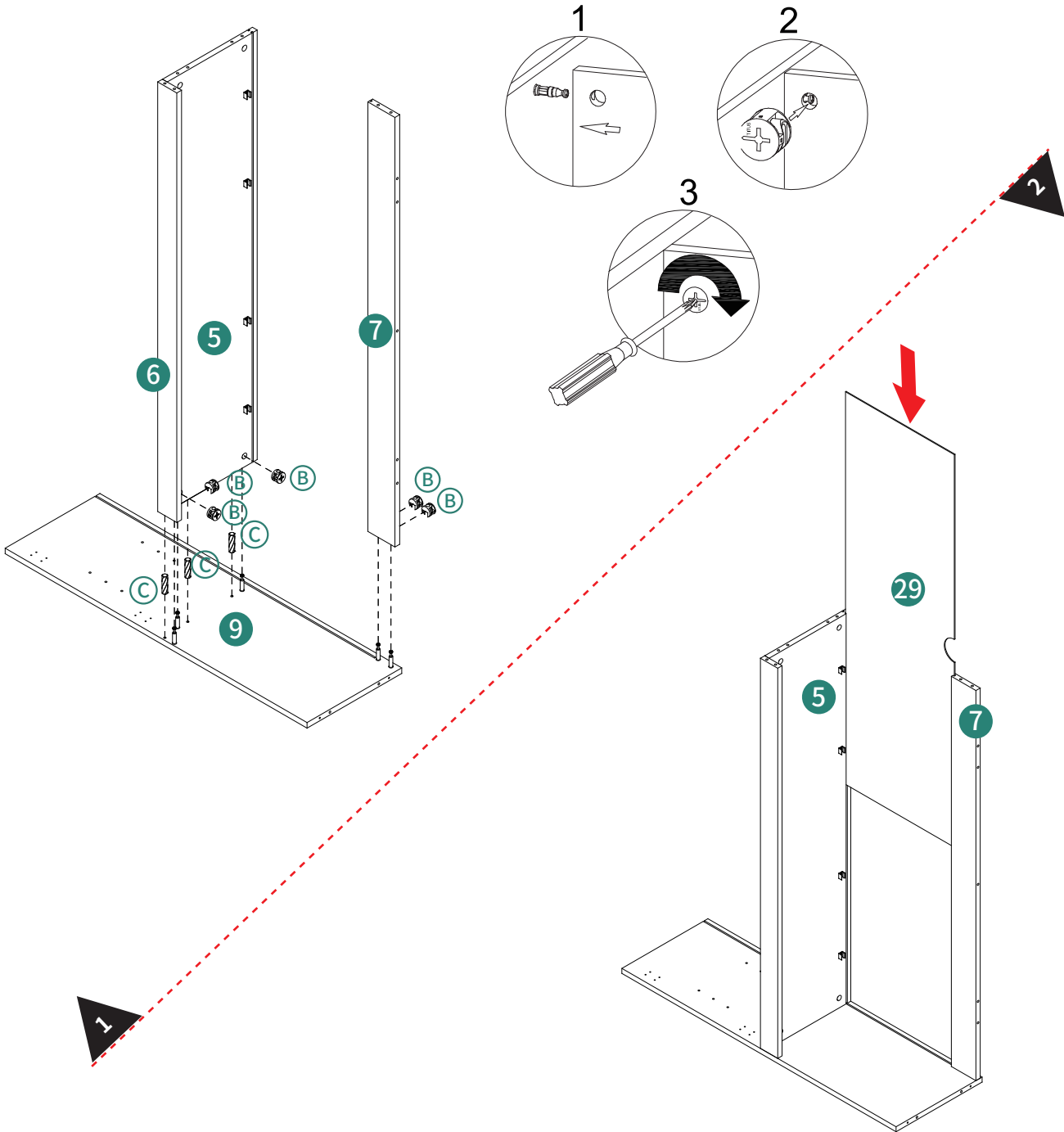
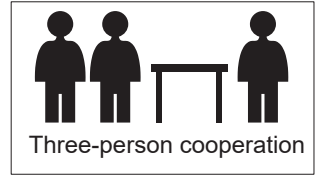

18



Ⓑ 5pcs

ST8X30mm

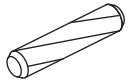

Ⓒ 3pcs



Three-person cooperation

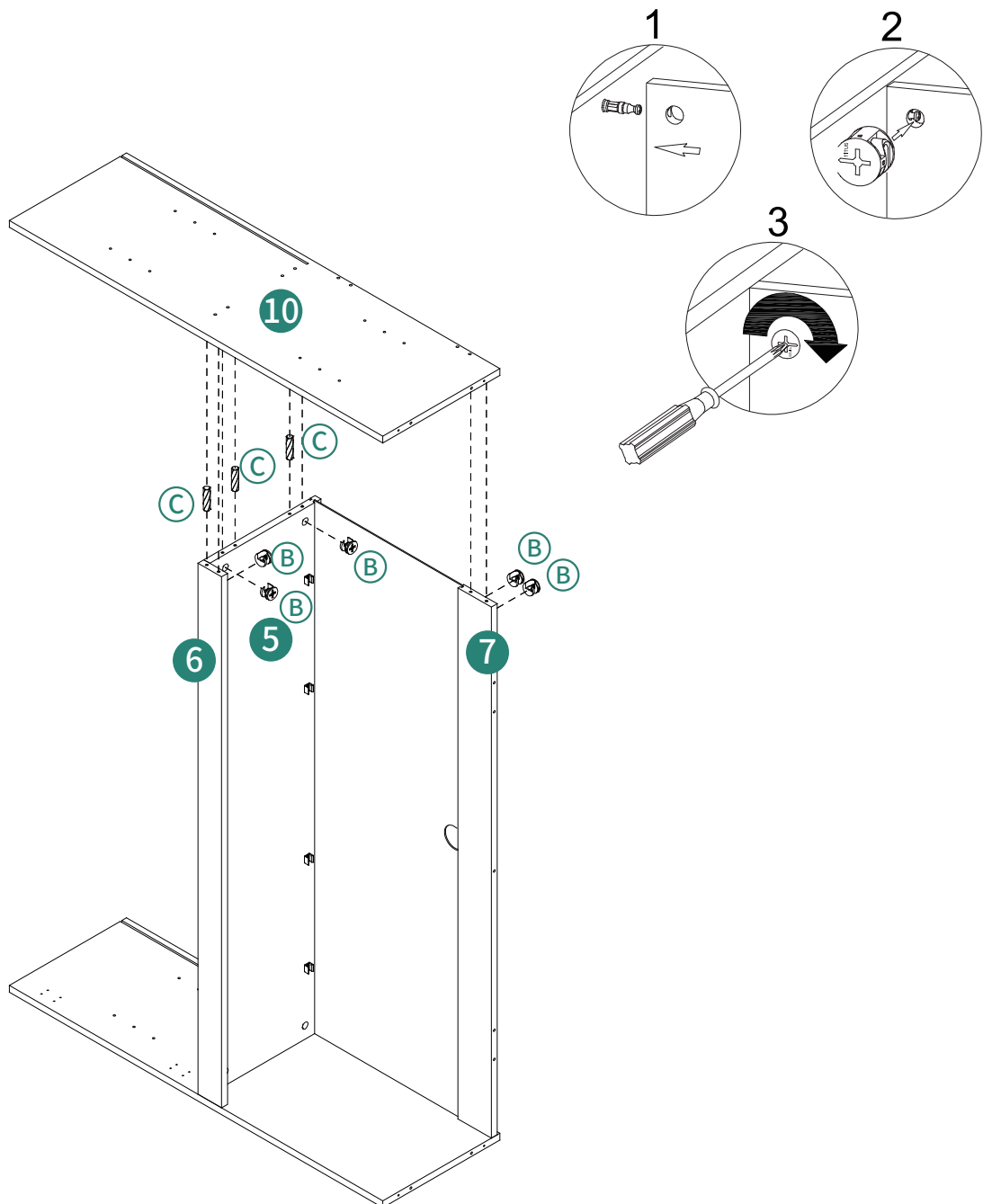

19

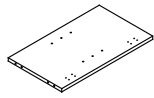

③ 1pc

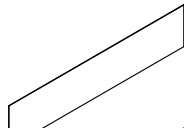

② 2pcs



② 1pc



② 2pcs

ST8X30mm

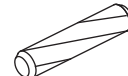

② 2pcs



Three-person cooperation

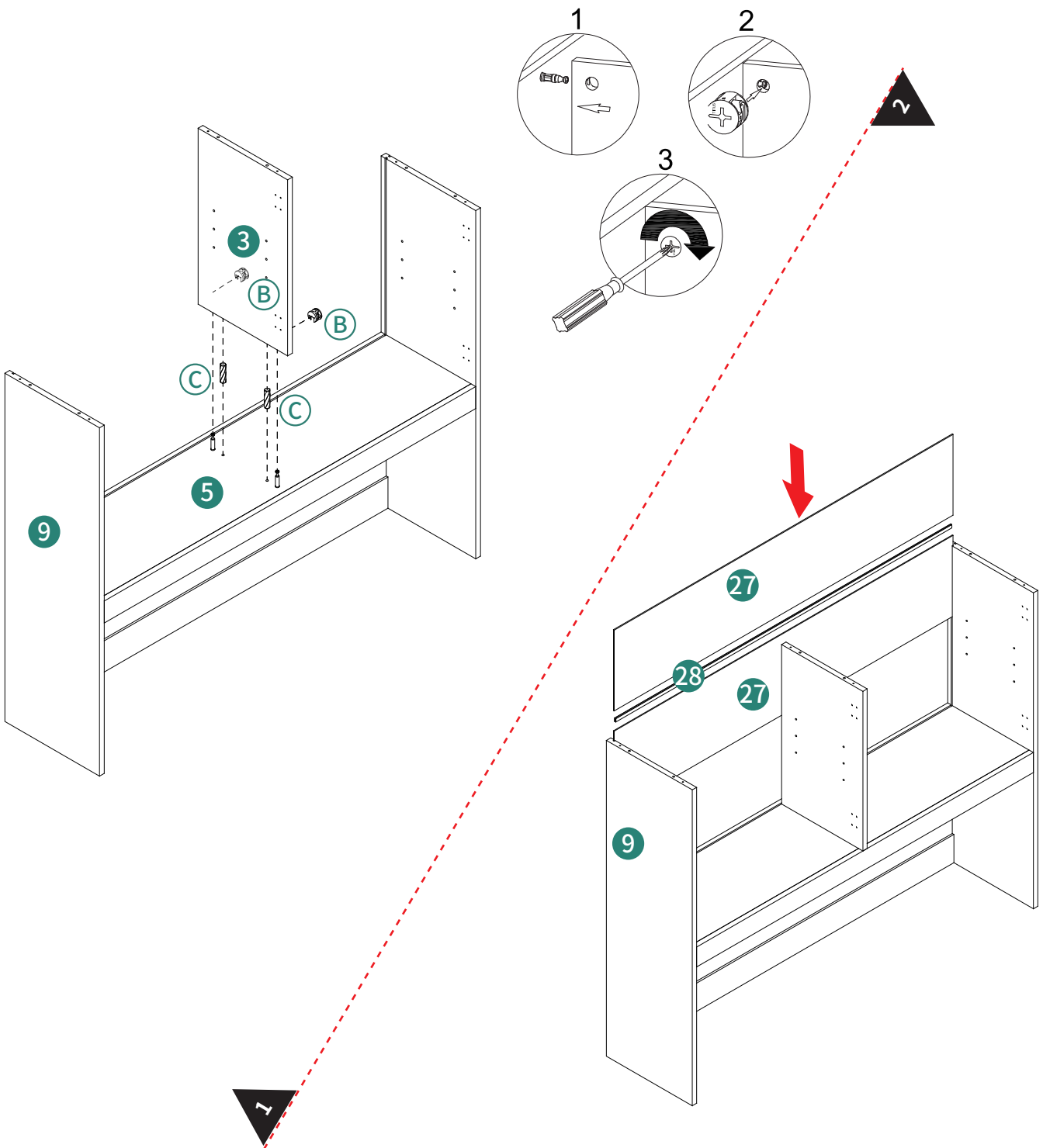

20

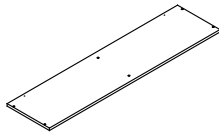

ST3X16mm



ST8X30mm

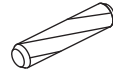

ST4X40mm

① 1pc ① 4pcs ③ 2pcs ④ 6pcs ⑤ 6pcs

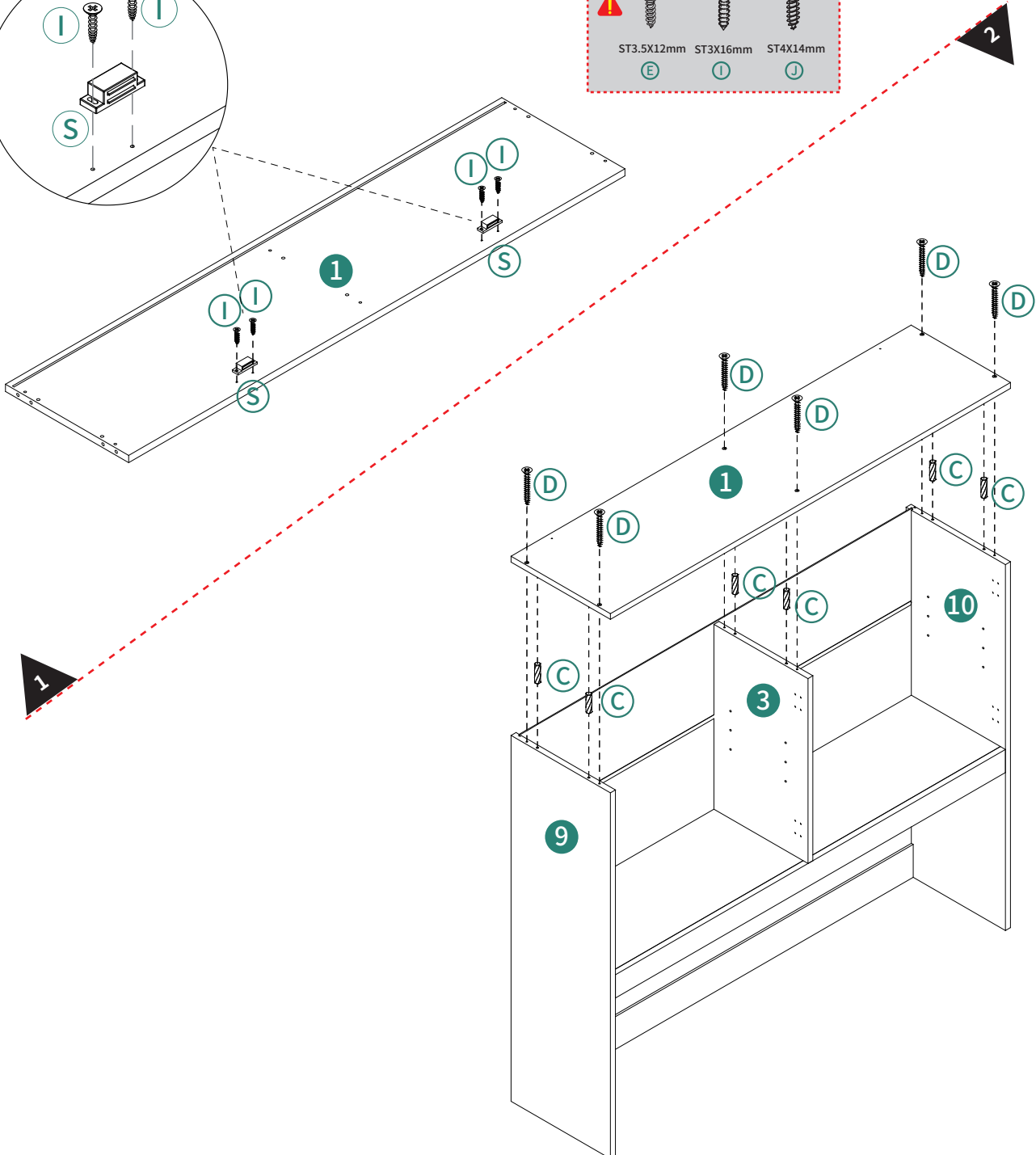
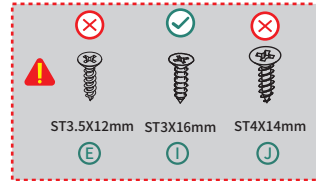
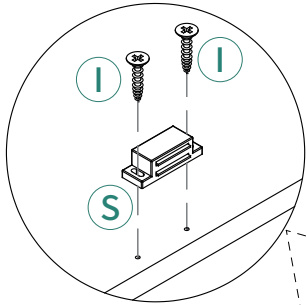
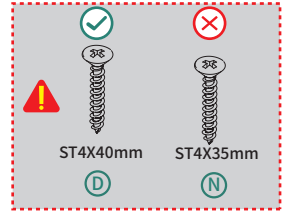

21

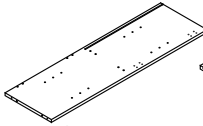

①11pc

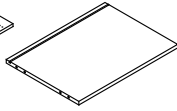

①13pc



Ⓐ12pcs

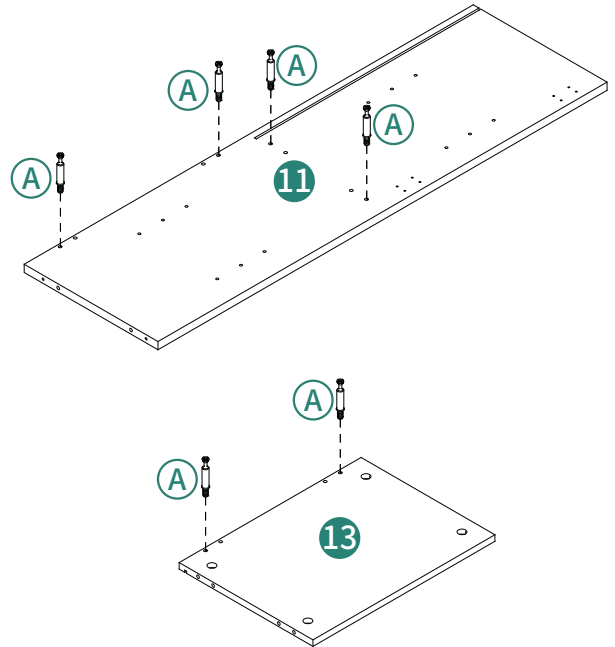
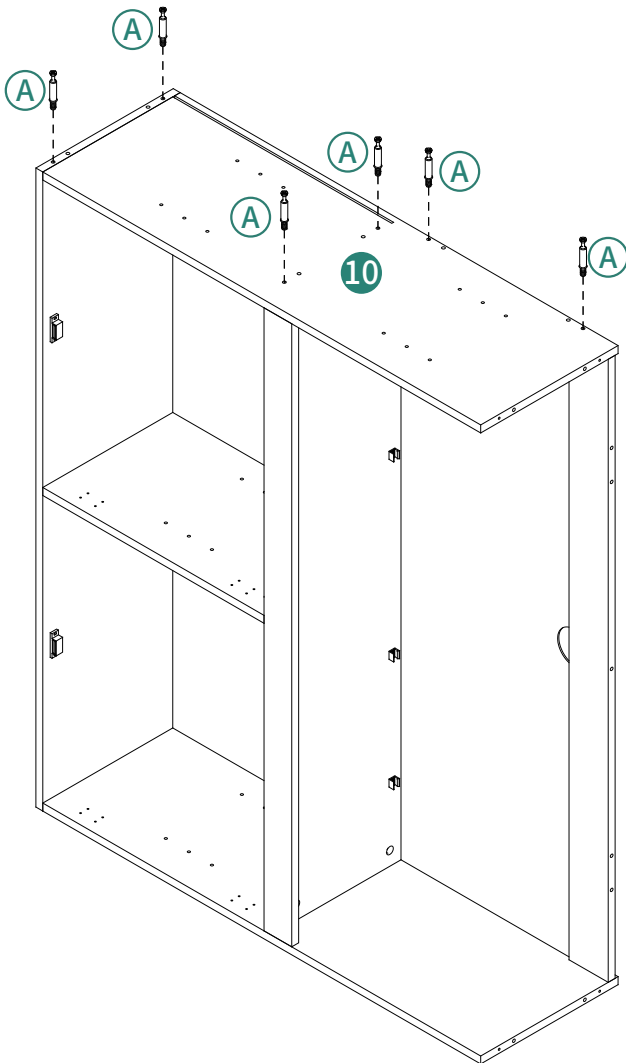
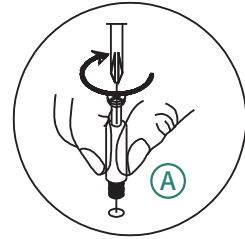
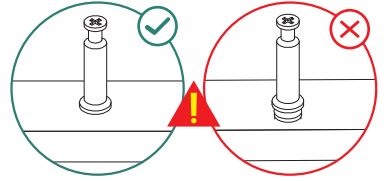

22

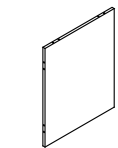

③1 1pc



④B 6pcs

ST8X30mm

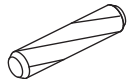

⑤C 6pcs

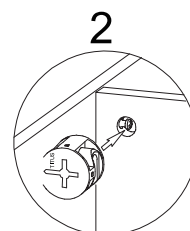
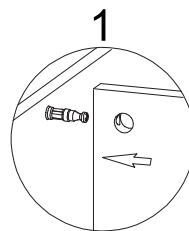

3

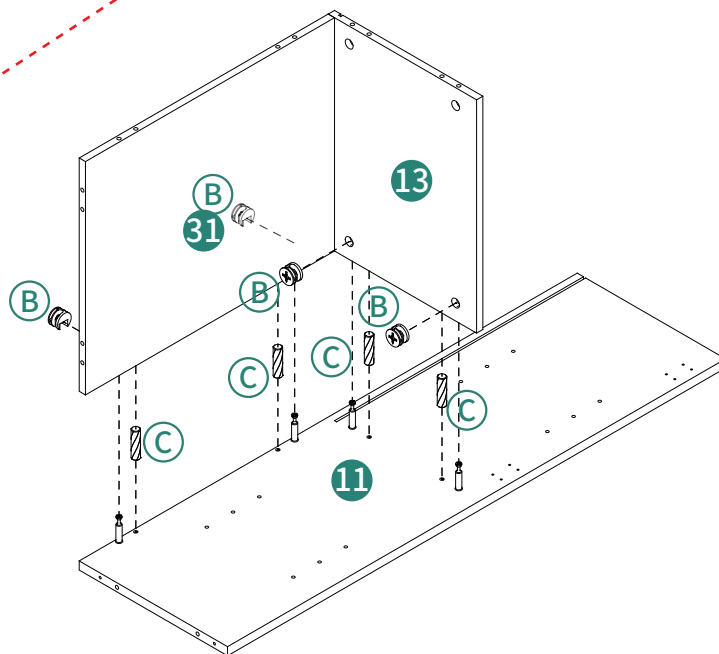
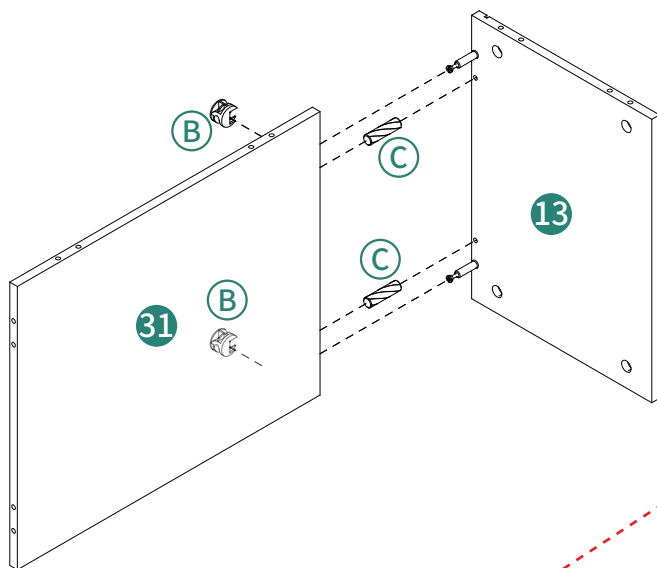
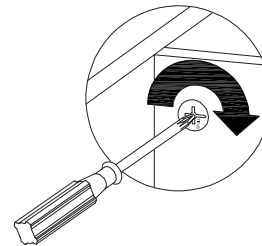

23

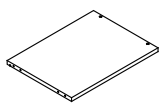

② 1pc

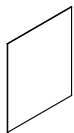

③ 1pc

ST8X30mm ST4X40mm

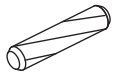

④ 2pcs

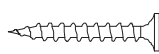

⑤ 2pcs

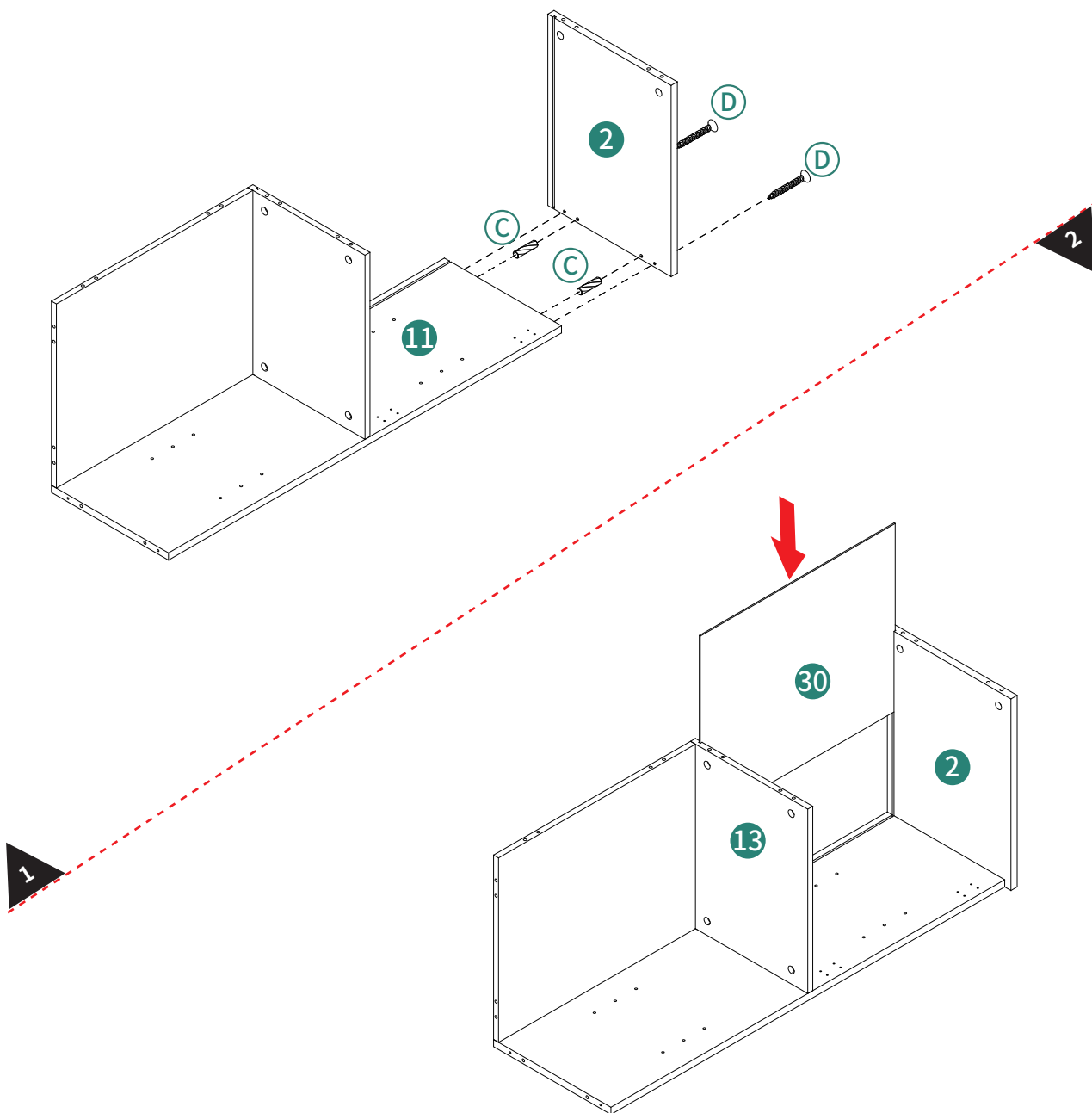
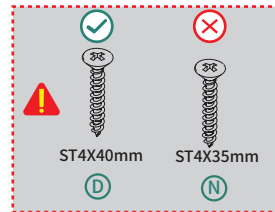

24

ST8X30mm



Ⓑ 6pcs Ⓒ 6pcs

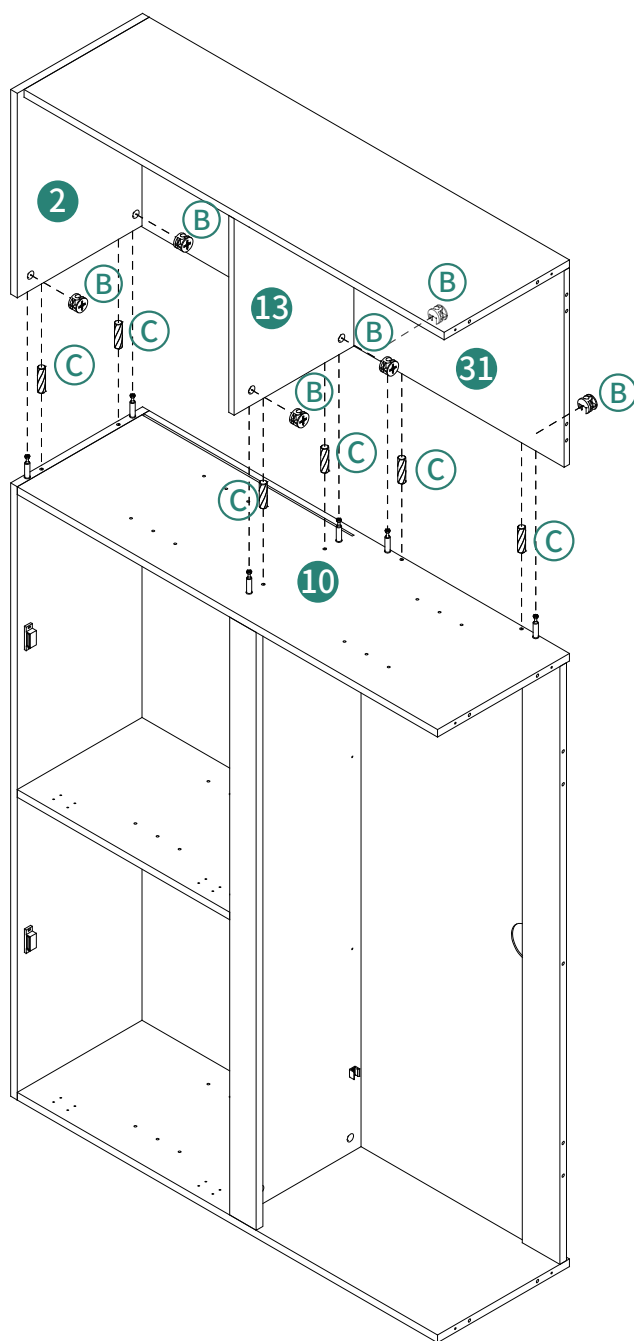
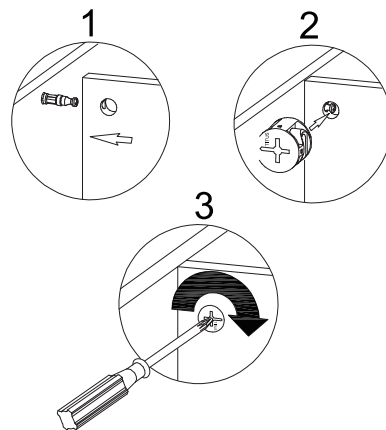

25

⑧ 1pc ⑭ 1pc ① 5pcs ② 2pcs **ST8X30mm**

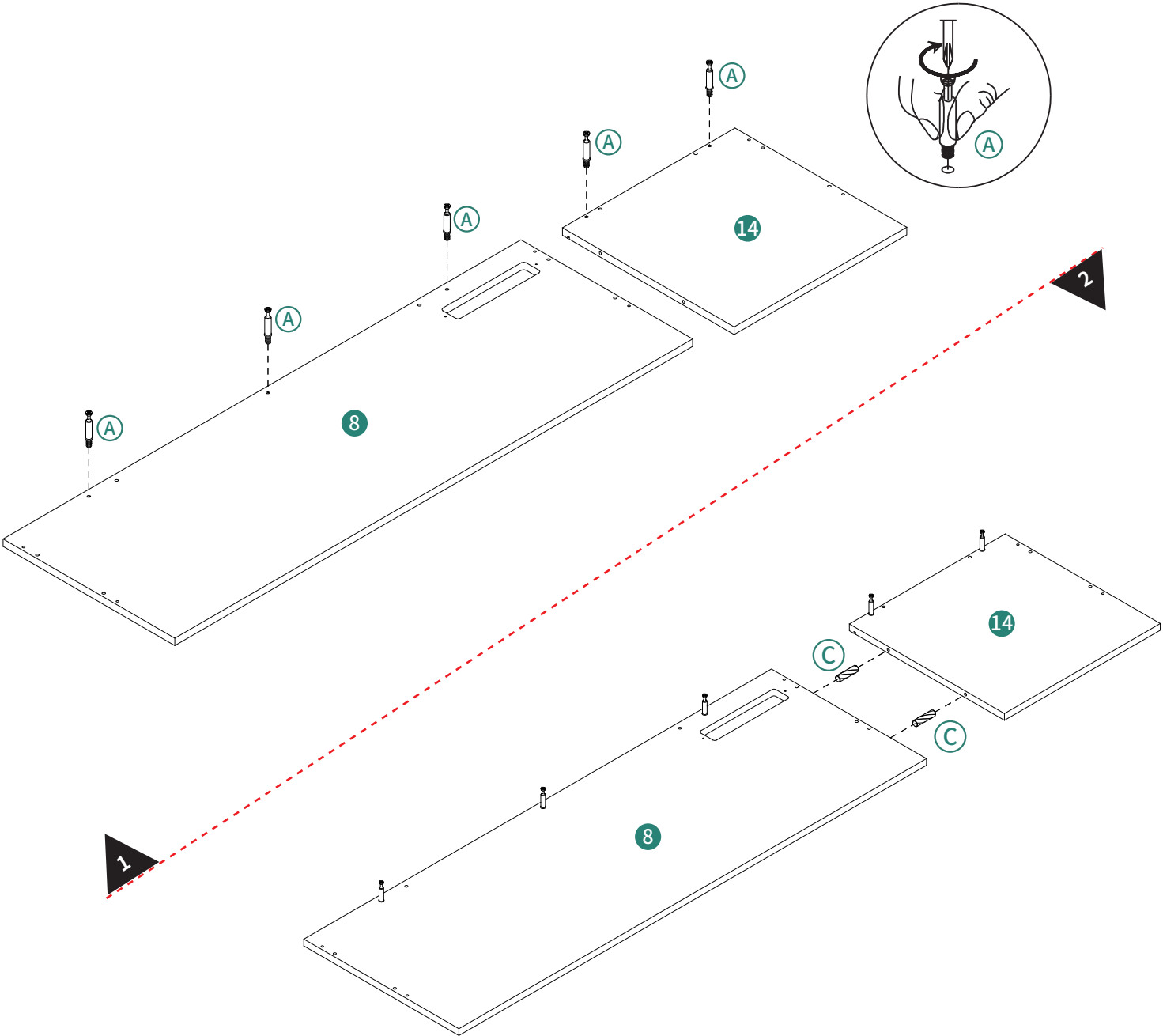
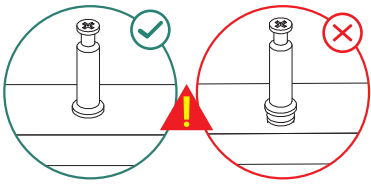

26

ST8X30mm ST4X40mm
ⓑ5pcs ⓒ10pcs ⓓ6pcs

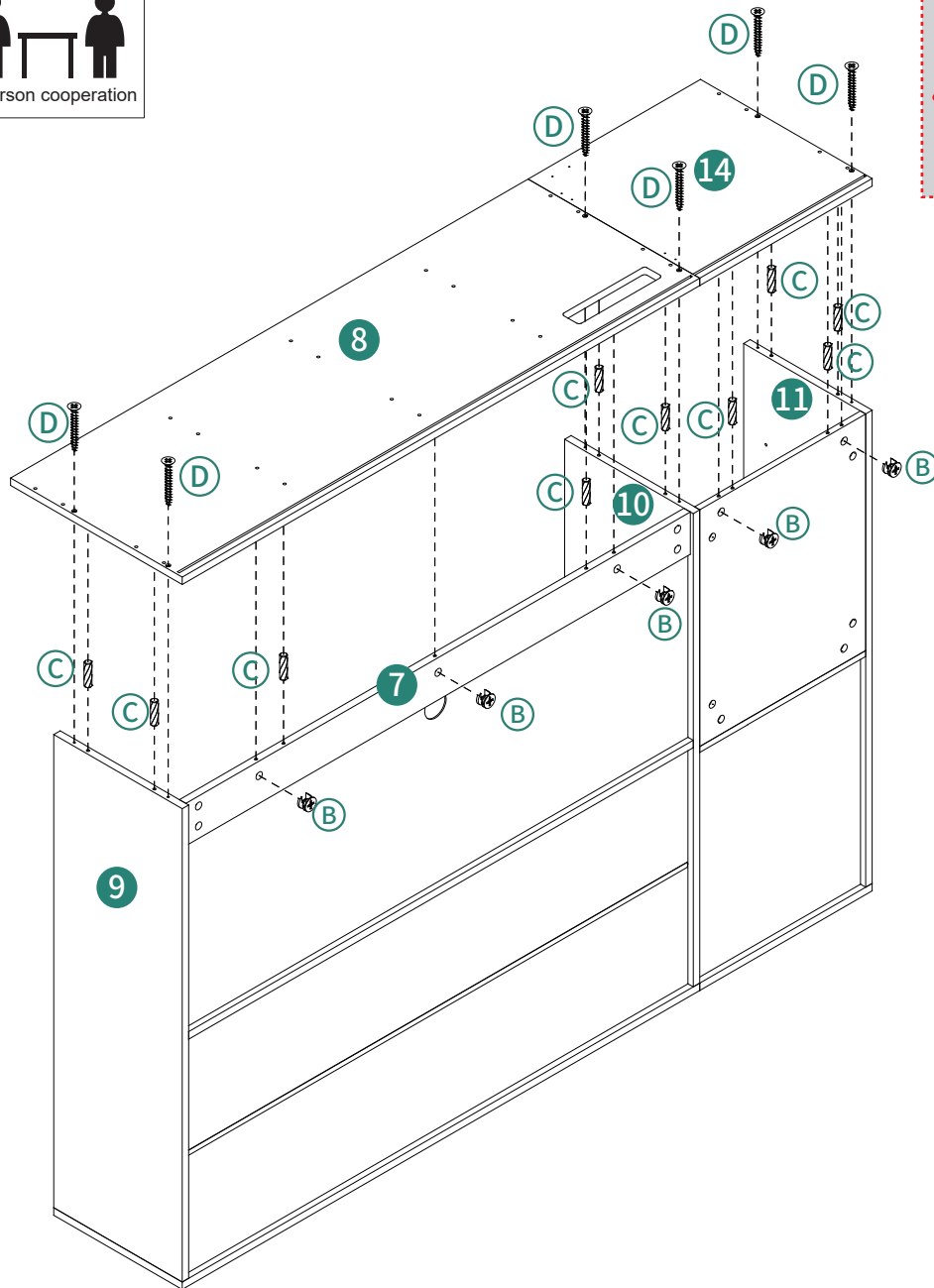
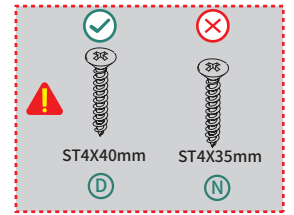
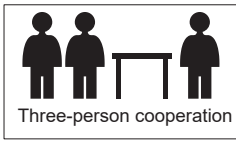
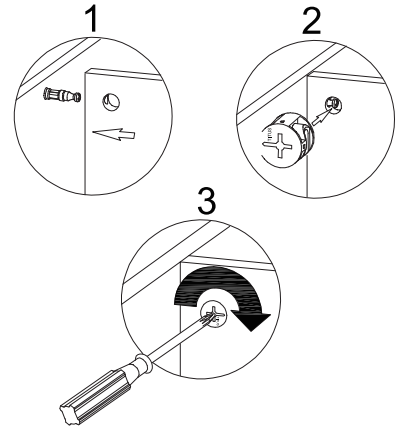

27

- ST3X16mm**
- A** 12pcs
 - I** 2pcs
 - S** 1pc

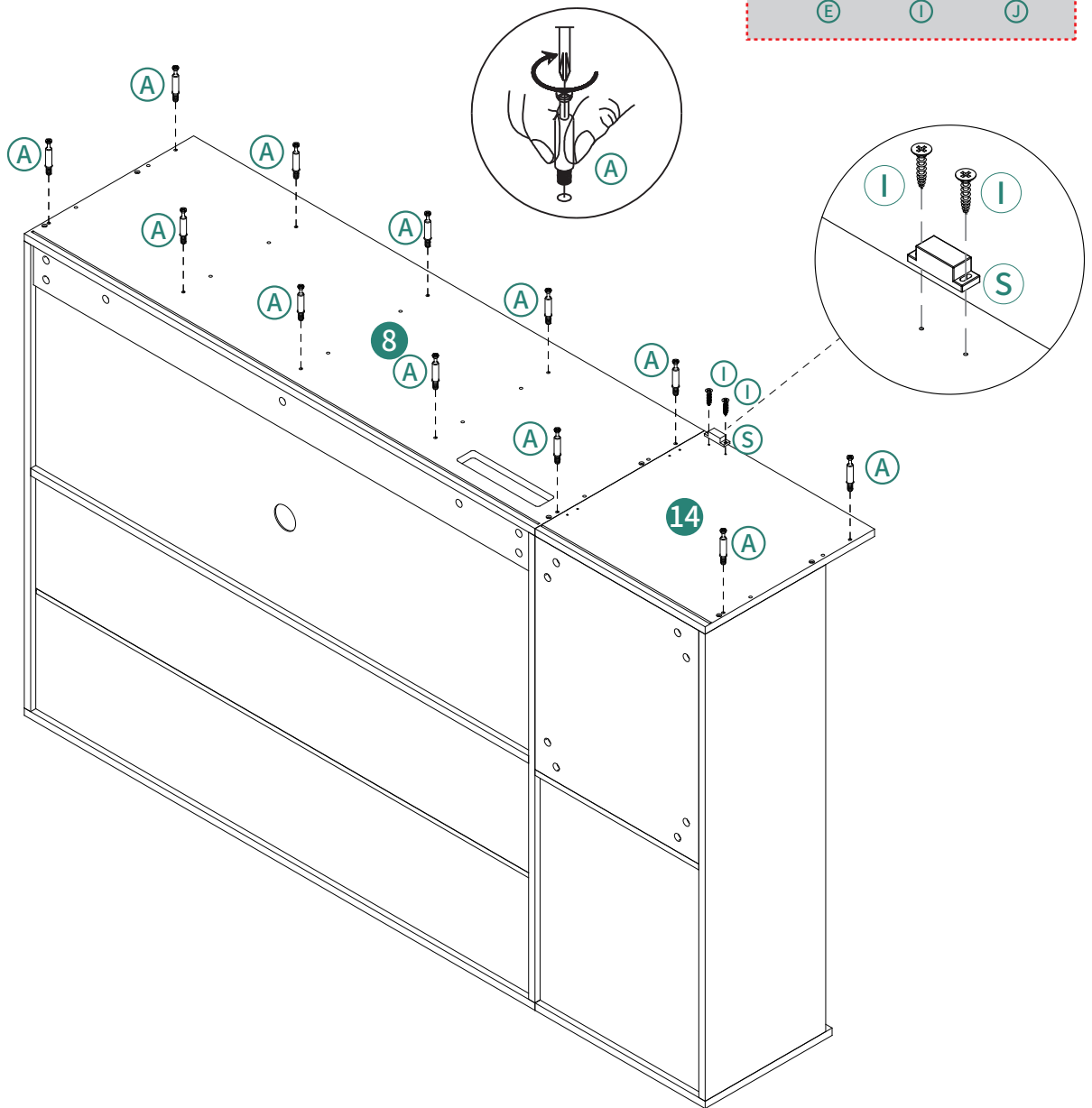
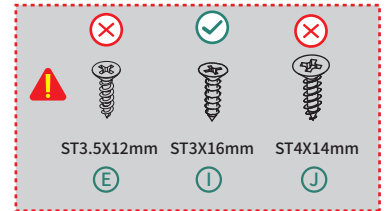
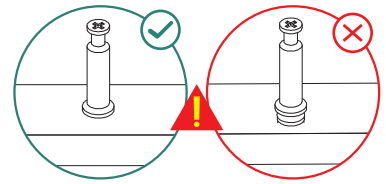

28

ST8X30mm



Ⓑ 12pcs Ⓒ 12pcs

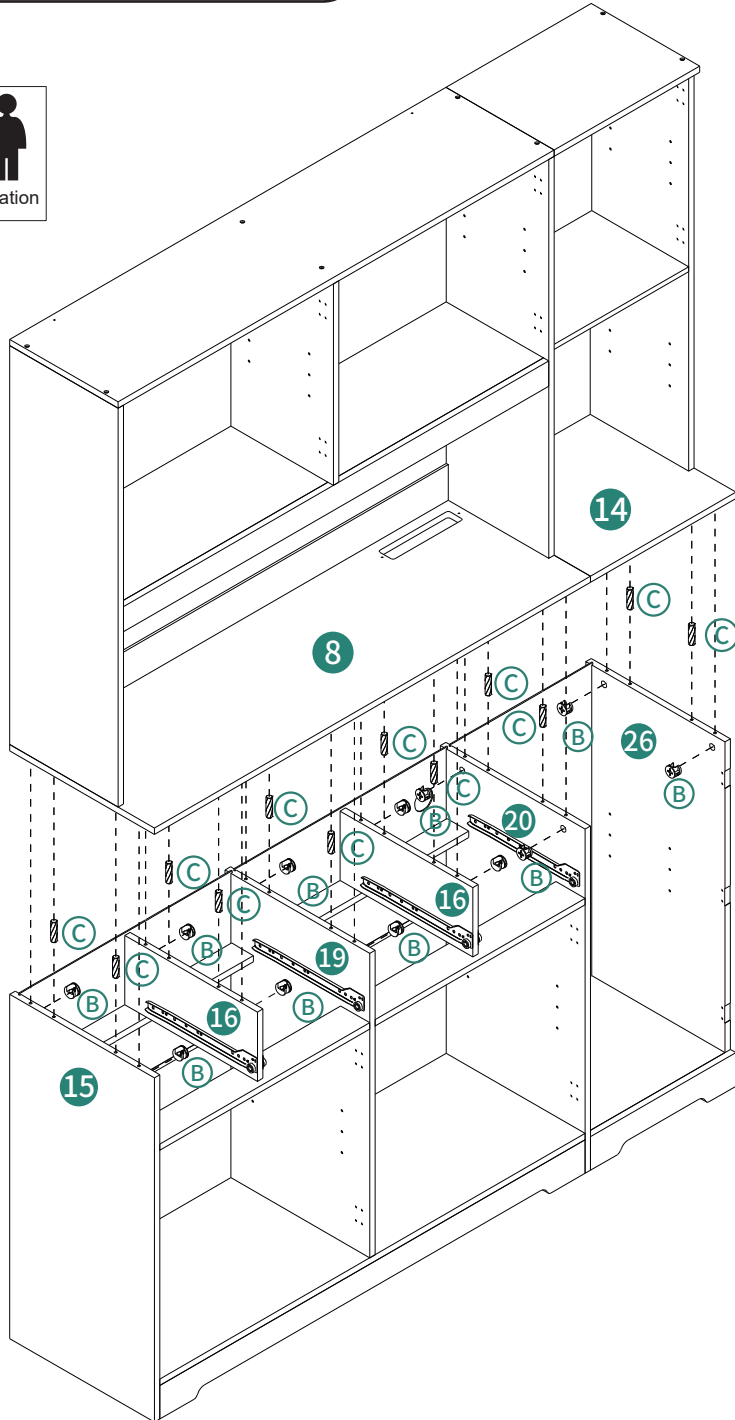
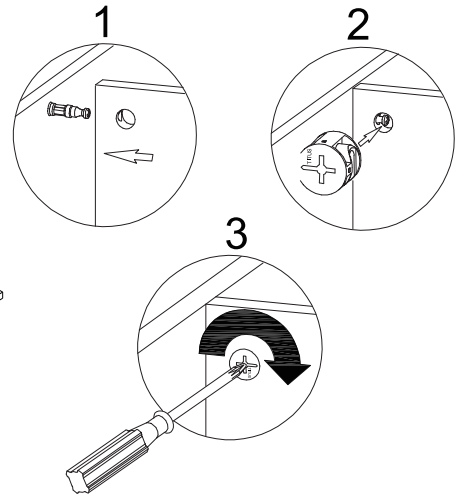
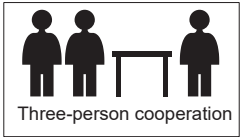

29

ST3.5X12mm



ⓔ10pcs

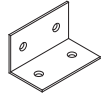

ⓓ2pcs

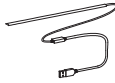

Ⓤ1pc

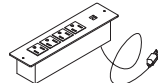

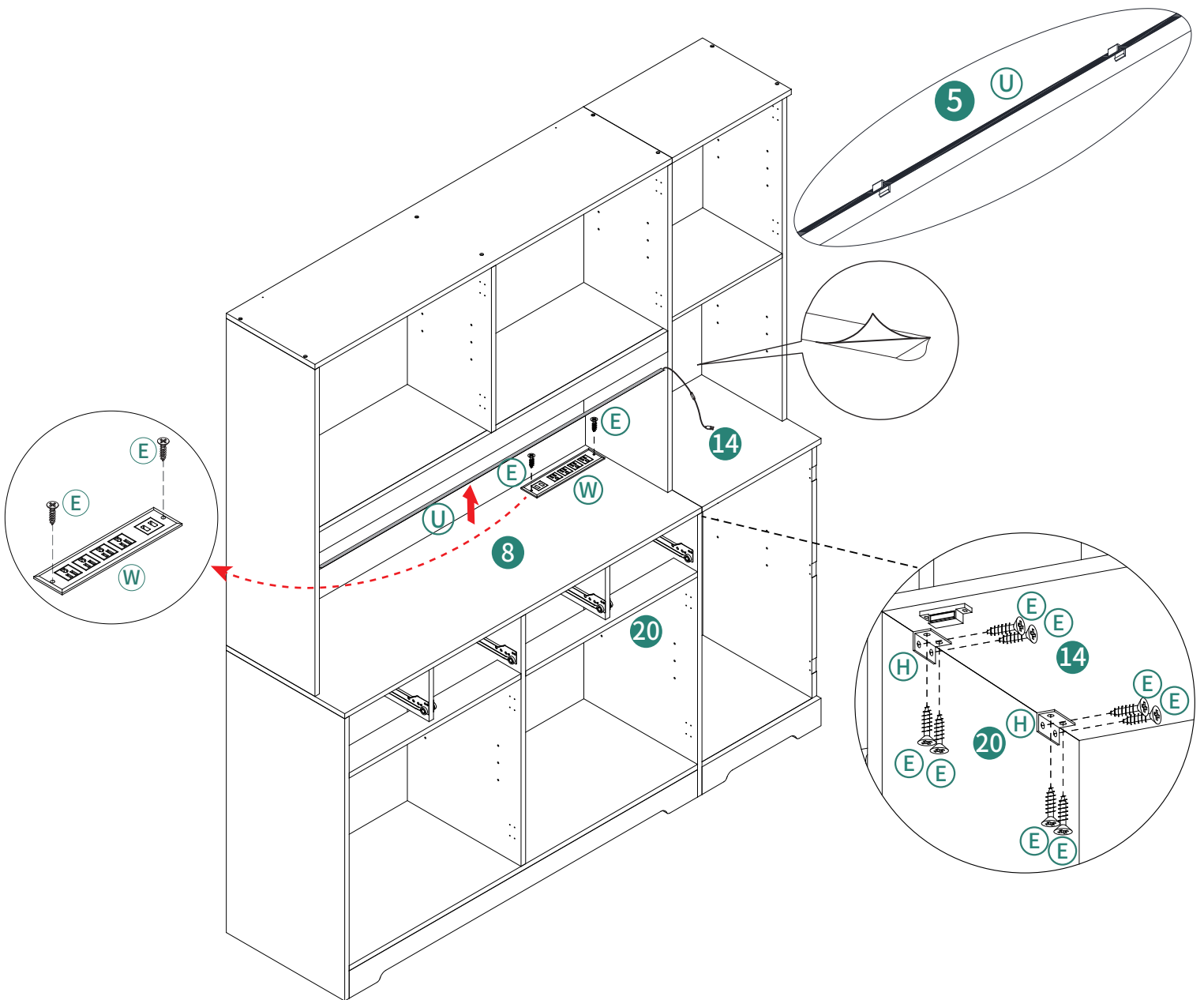
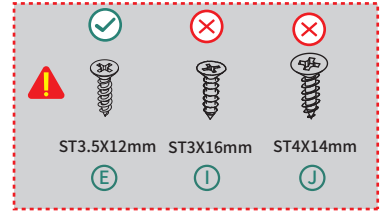

Ⓦ1pc



30

ST3X16mm



ⓕ 42pcs Ⓡ 42pcs

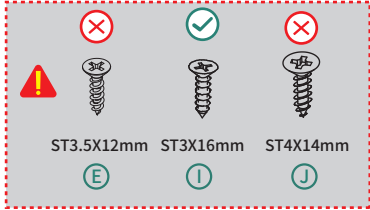

ST3.5X12mm ST3X16mm ST4X14mm

ⓔ Ⓡ ⓙ

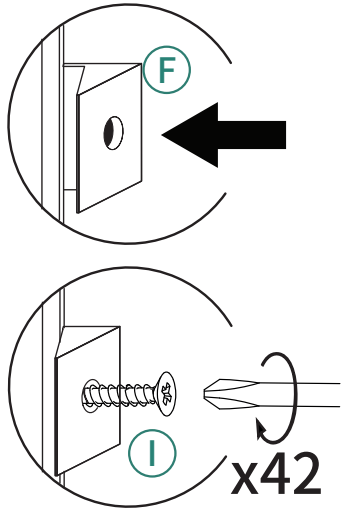
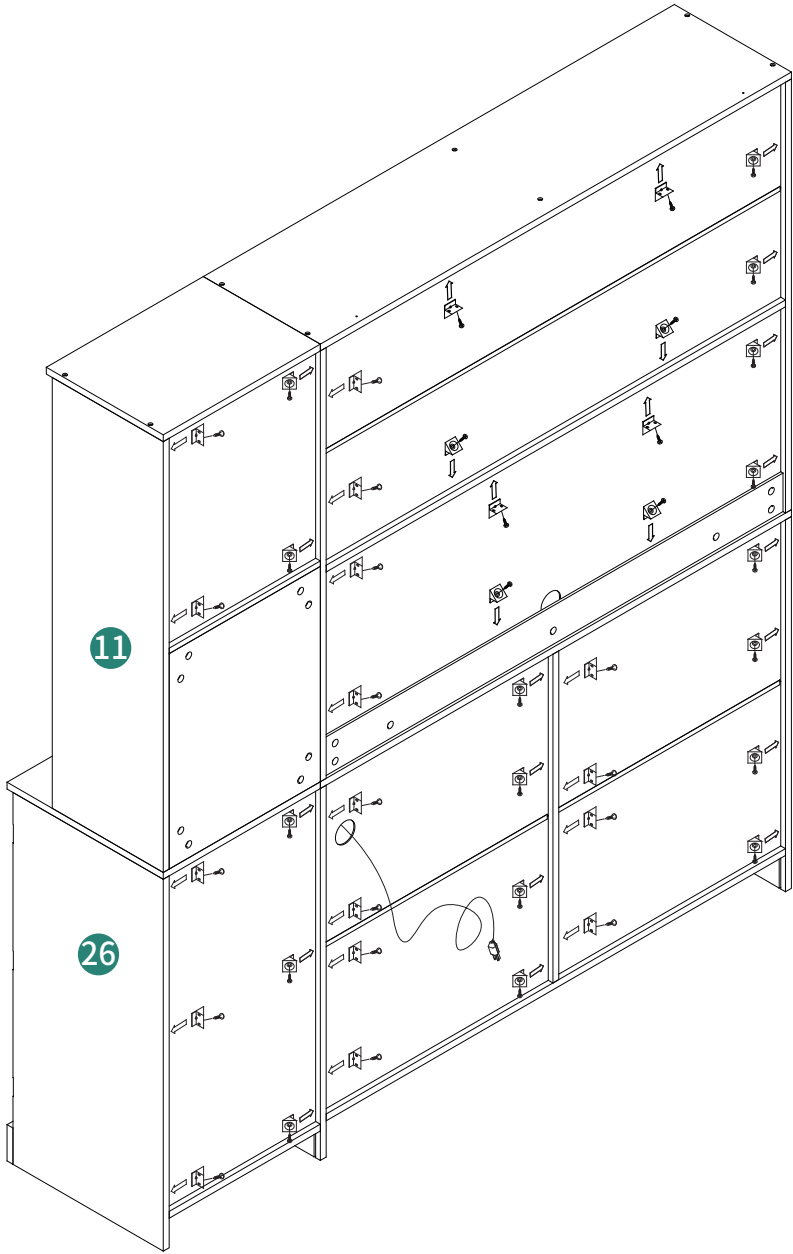

31

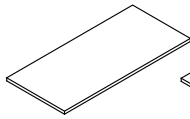

④ 2 pcs

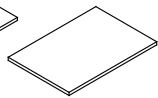

⑫ 3 pcs

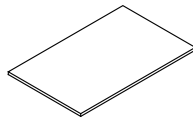

⑱ 2 pcs



Ⓚ 28 pcs

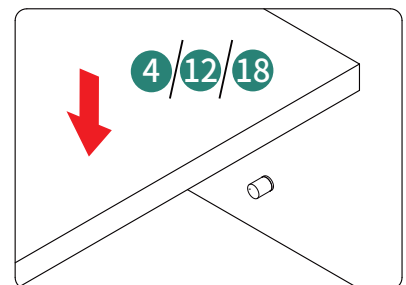
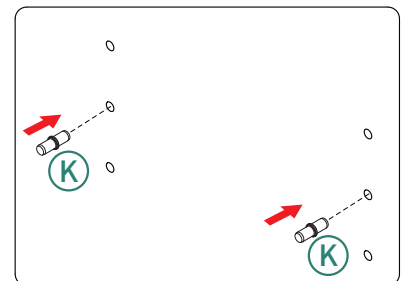
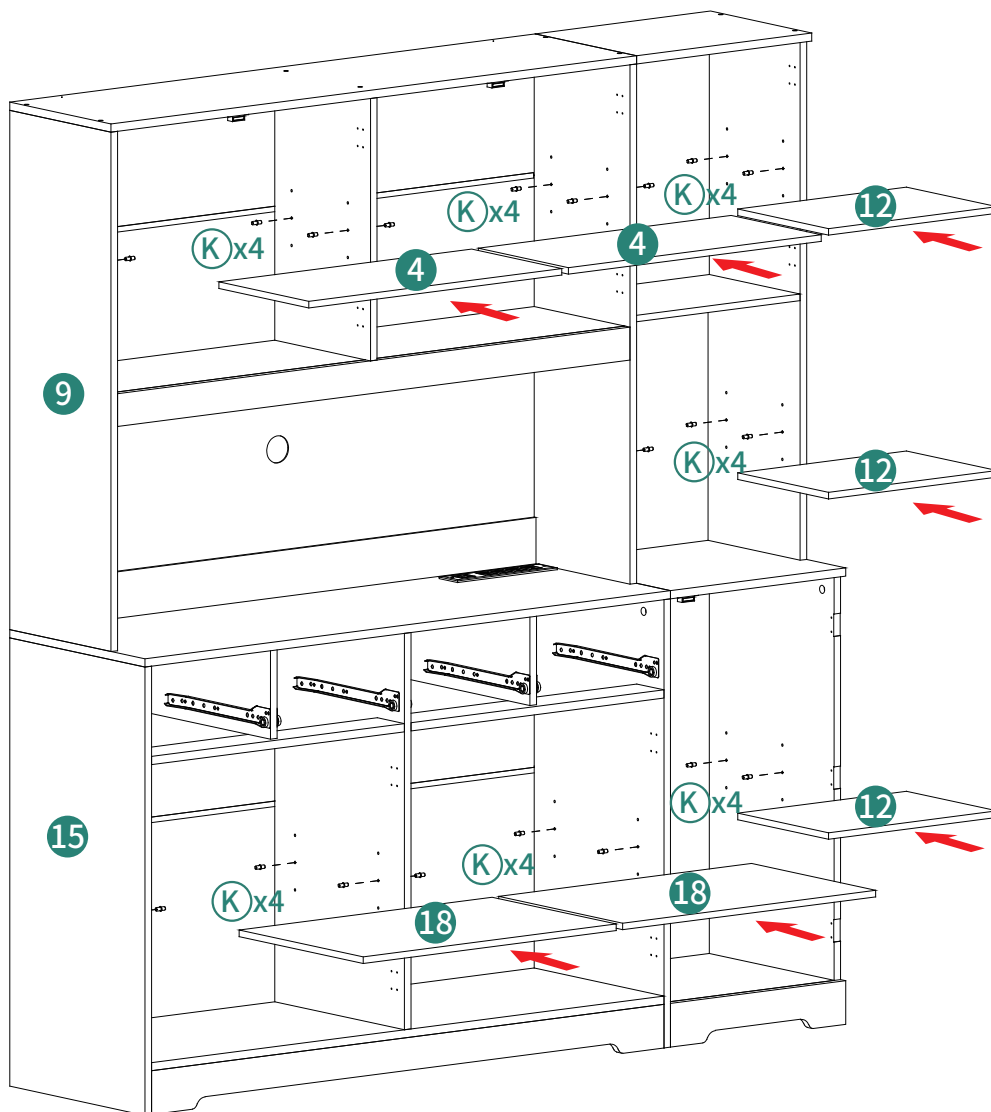

32
X2

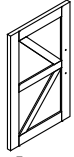

36 4pcs

ST4X14mm



J 16pcs

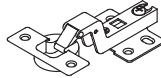

O 8pcs

ST3.5X12mm



E 4pcs



Q 4pcs



V 4pcs

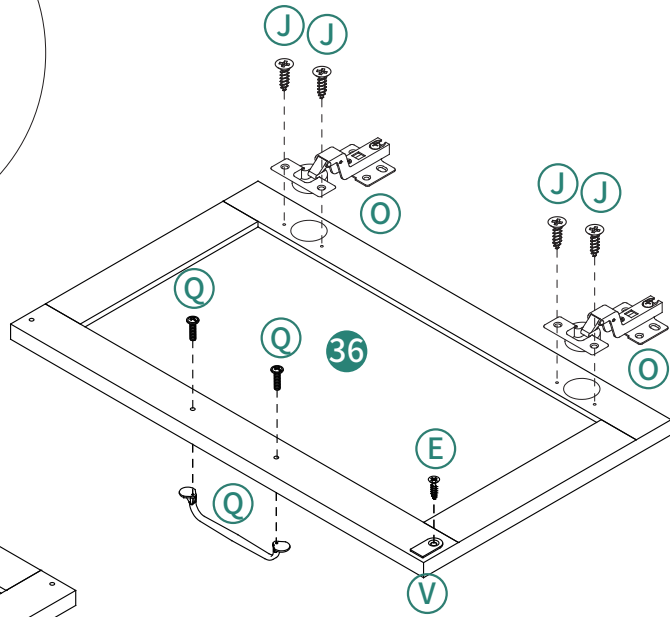
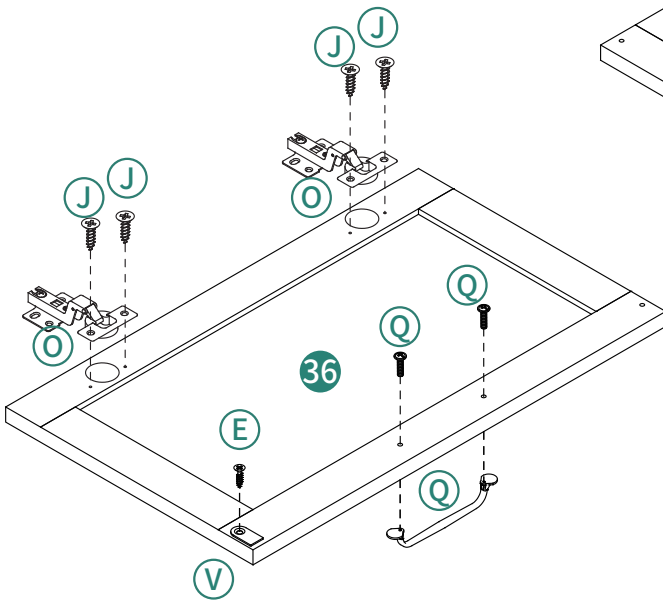
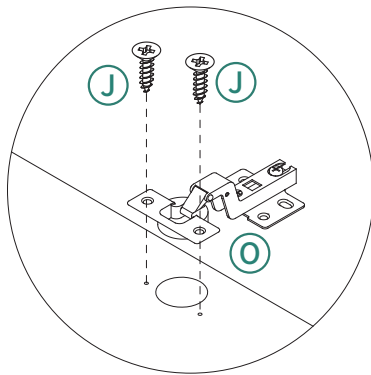
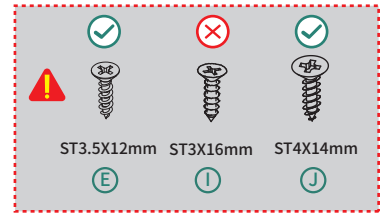

33
X2



ST4X14mm

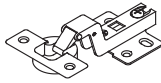

ST3.5X12mm



④4pcs ①J16pcs ①O8pcs ①E4pcs ①Q4pcs ①V4pcs

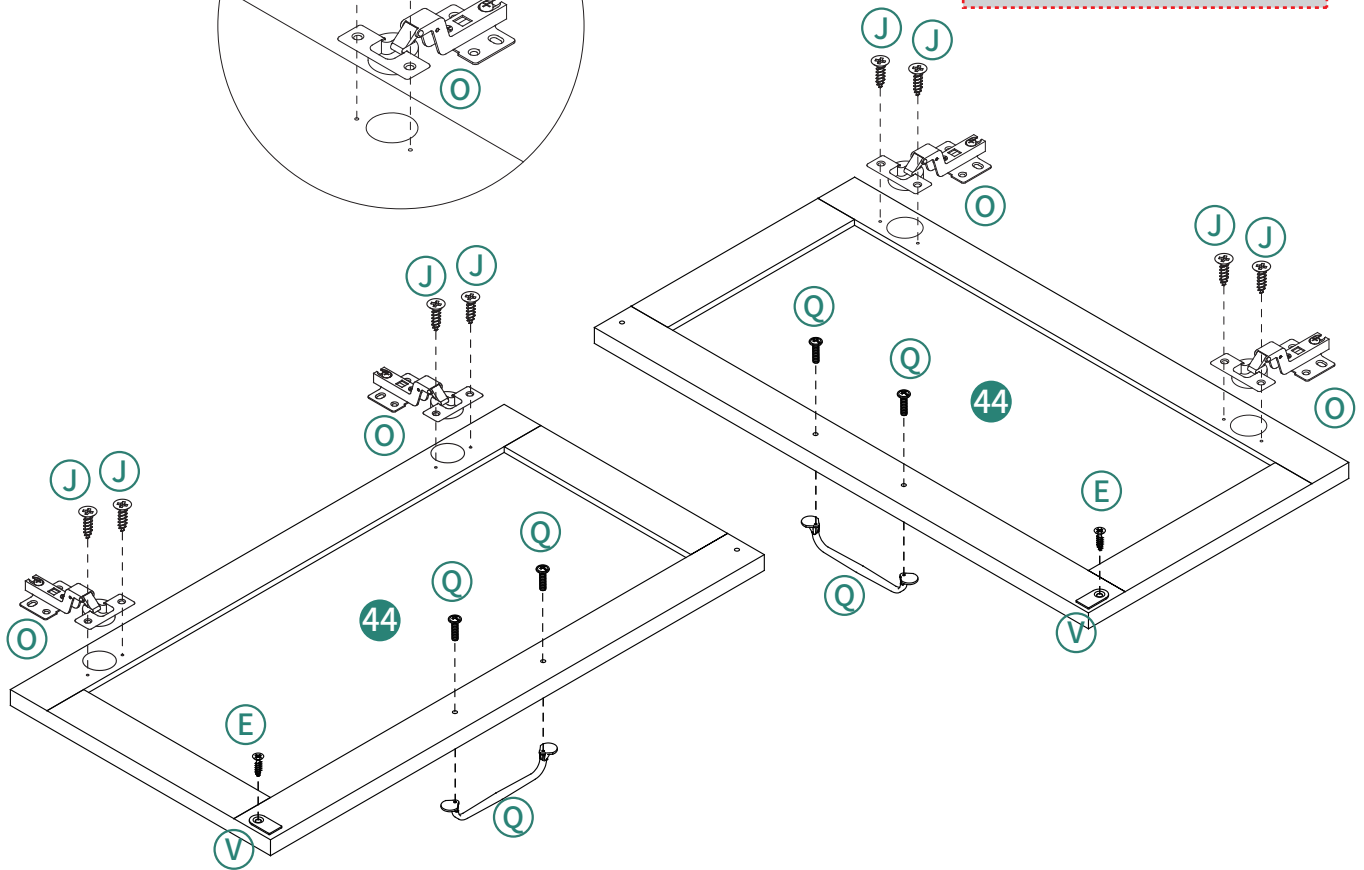
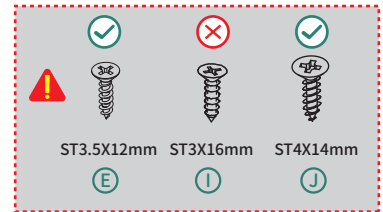
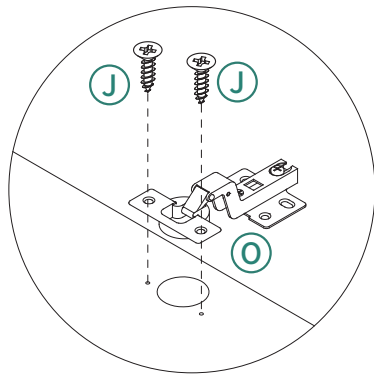

34

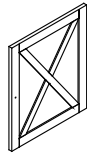

38 1pc

ST4X14mm



J 4pcs

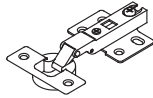

L 2pcs

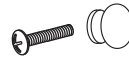

P 1pc

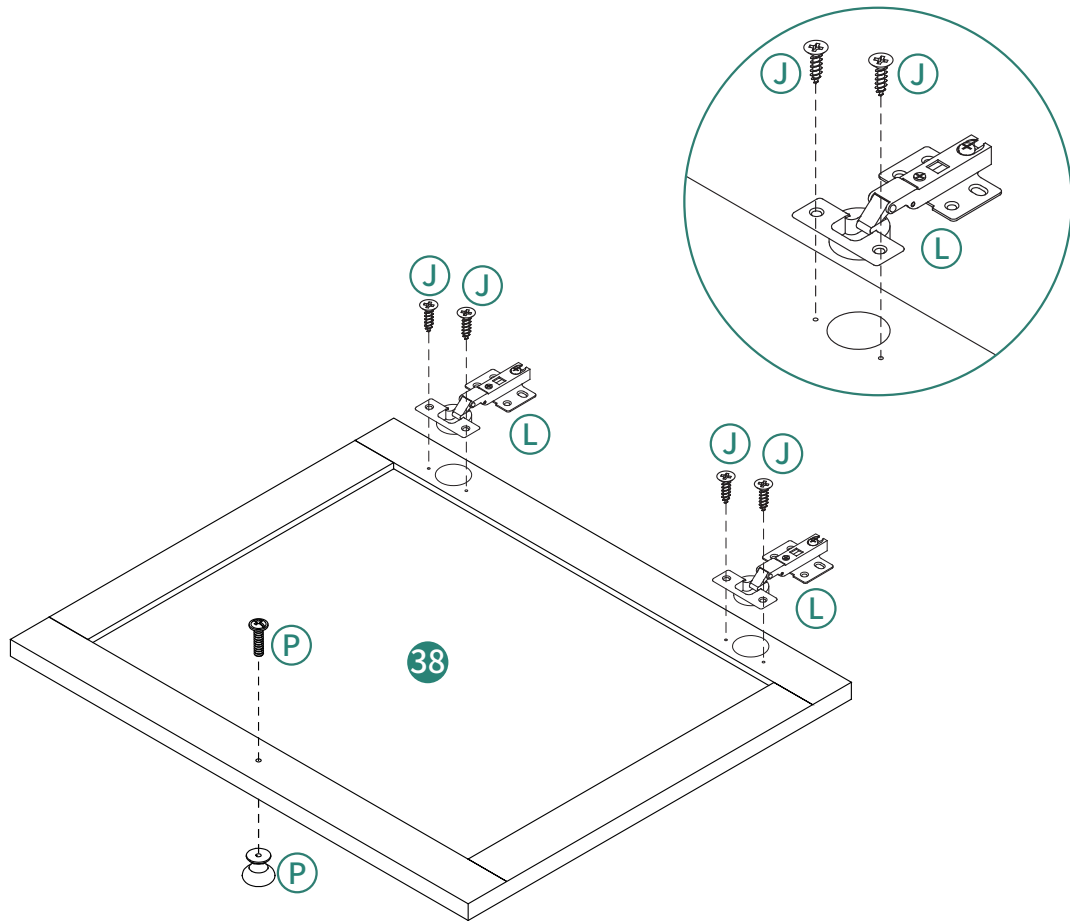
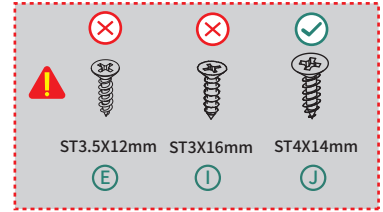

35

- 40 1pc
 - 41 1pc
 - 42 3pcs
 - 43 3pcs
 - A 6pcs
 - B 6pcs
 - C 6pcs
- ST8X30mm

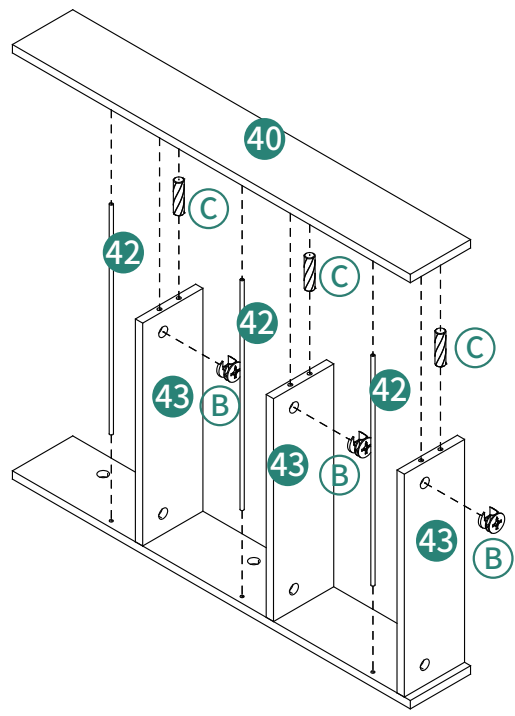
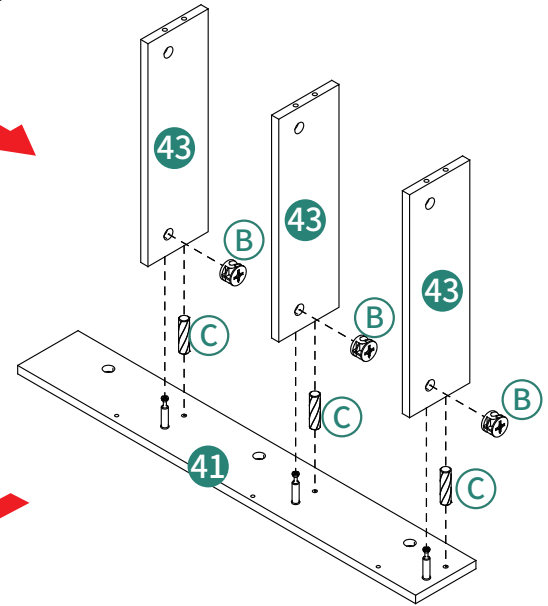
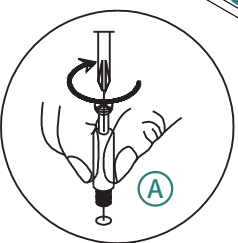
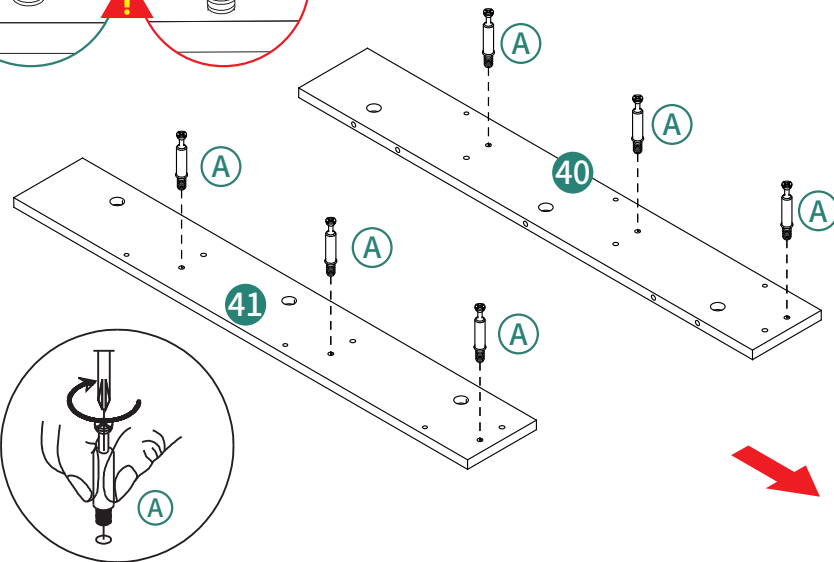
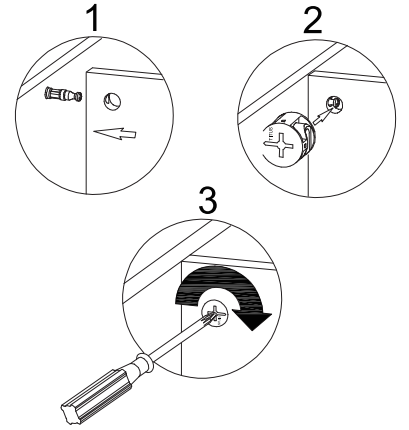
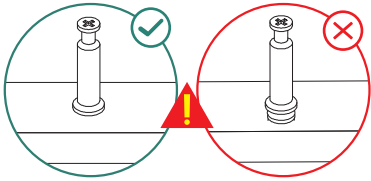

36

- ③9 1pc ①A 6pcs ①B 6pcs ①C 4pcs ①E 2pcs ①P 1pc ①R 1pc
- ST8X30mm ST3.5X12mm

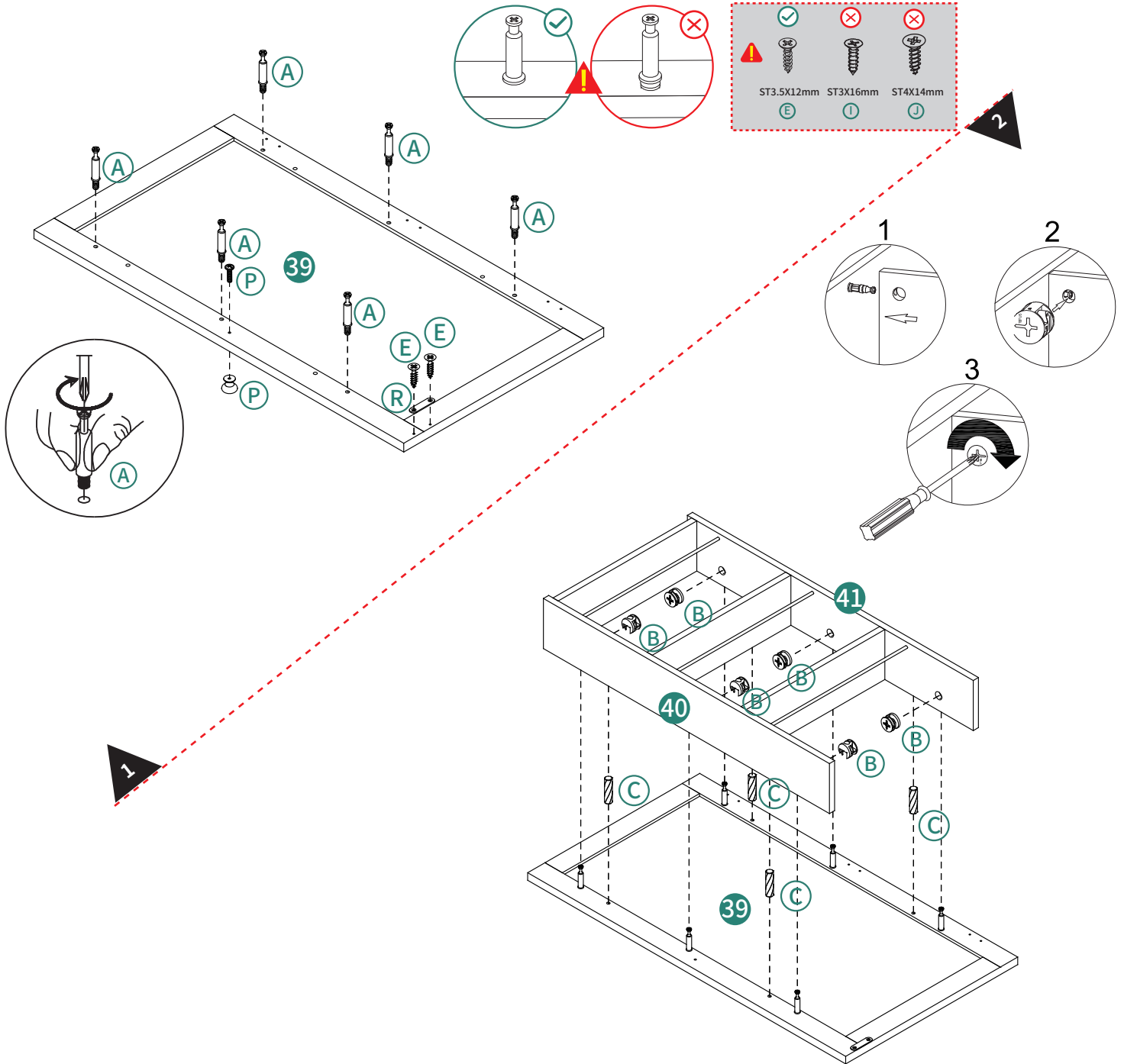

37

ST4X14mm

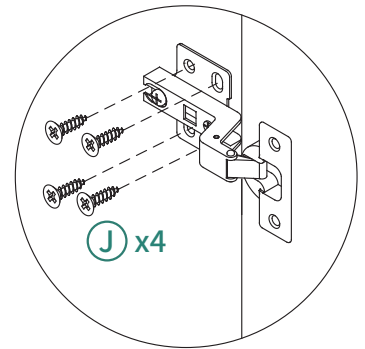
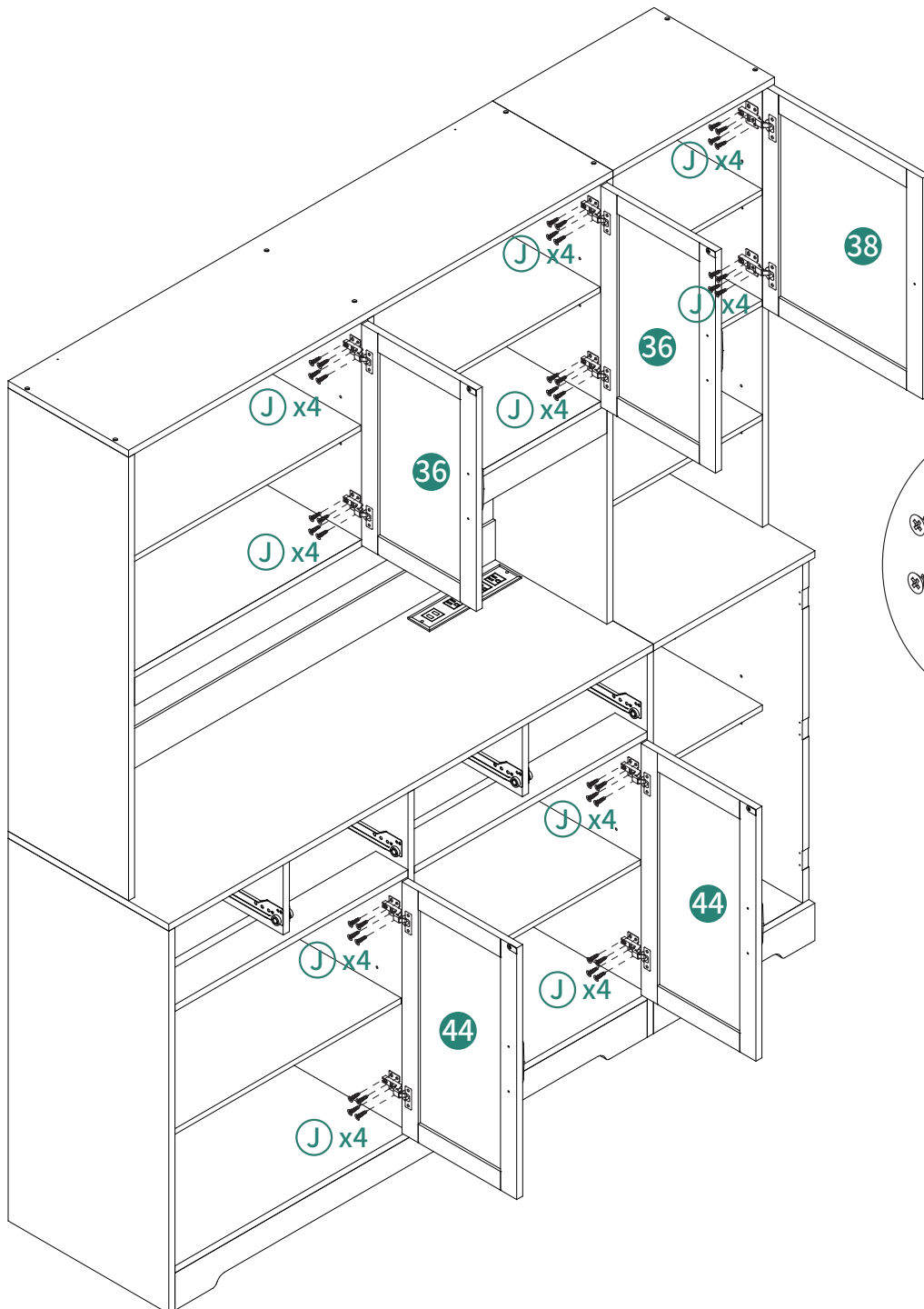
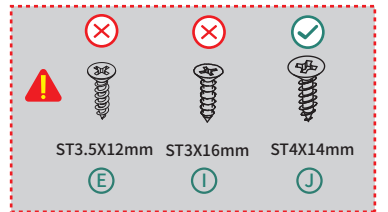
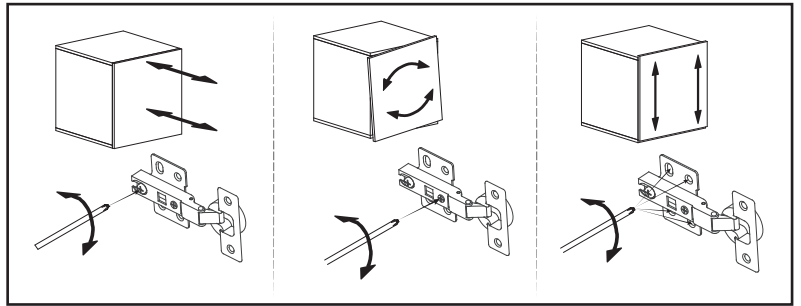
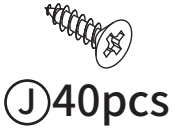

38

ST4X14mm



ⓐ 32pcs

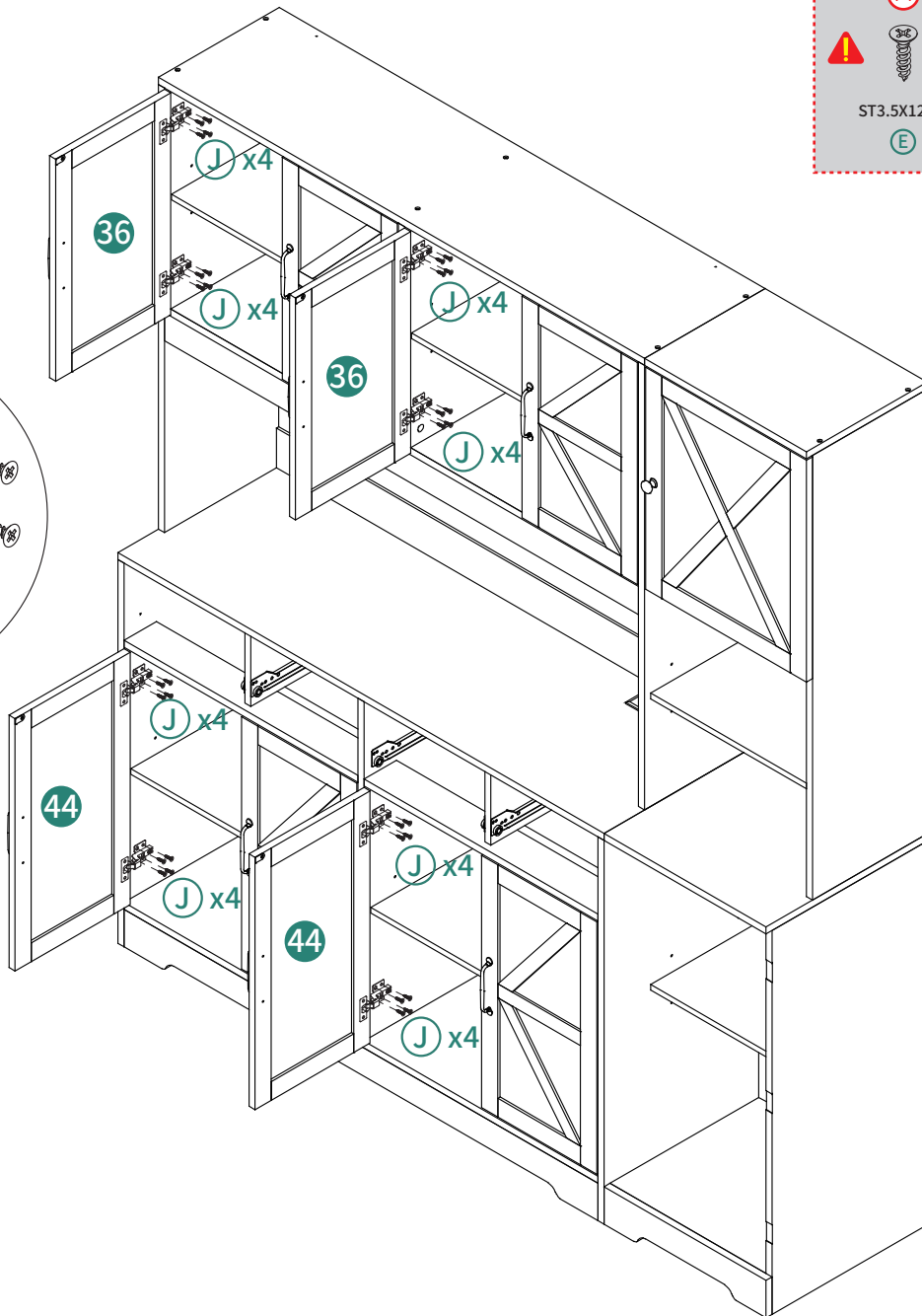
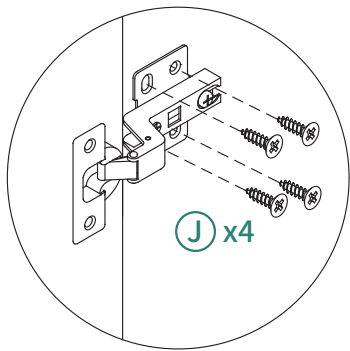
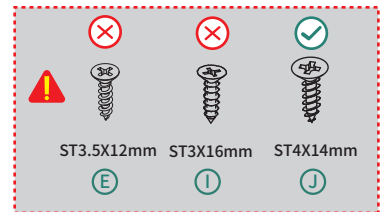
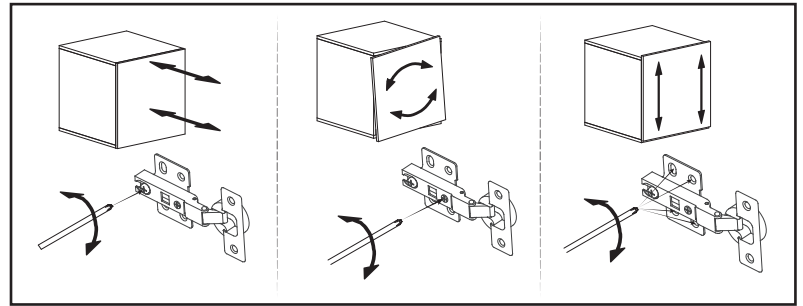

40
X4

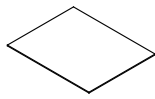

④54pcs

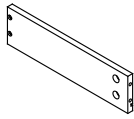

④84pcs

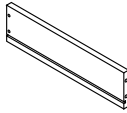

④94pcs

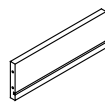

⑤04pcs

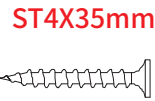

ST4X35mm

①16pcs

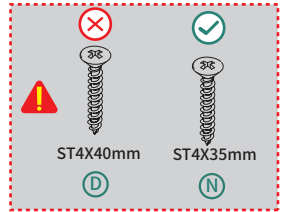

Note: Make sure the positions marked by triangles are facing the same direction.

Hinweis: Stellen Sie sicher, dass die Positionen, die durch Dreiecke markiert sind, in die gleiche Richtung zeigen.

Note : Assurez-vous que les positions marquées par des triangles sont orientées dans la même direction.

Nota: Assicurati che le posizioni contrassegnate da triangoli siano rivolte nella stessa direzione.

Nota: Asegúrate de que las posiciones marcadas con triángulos estén orientadas en la misma dirección.

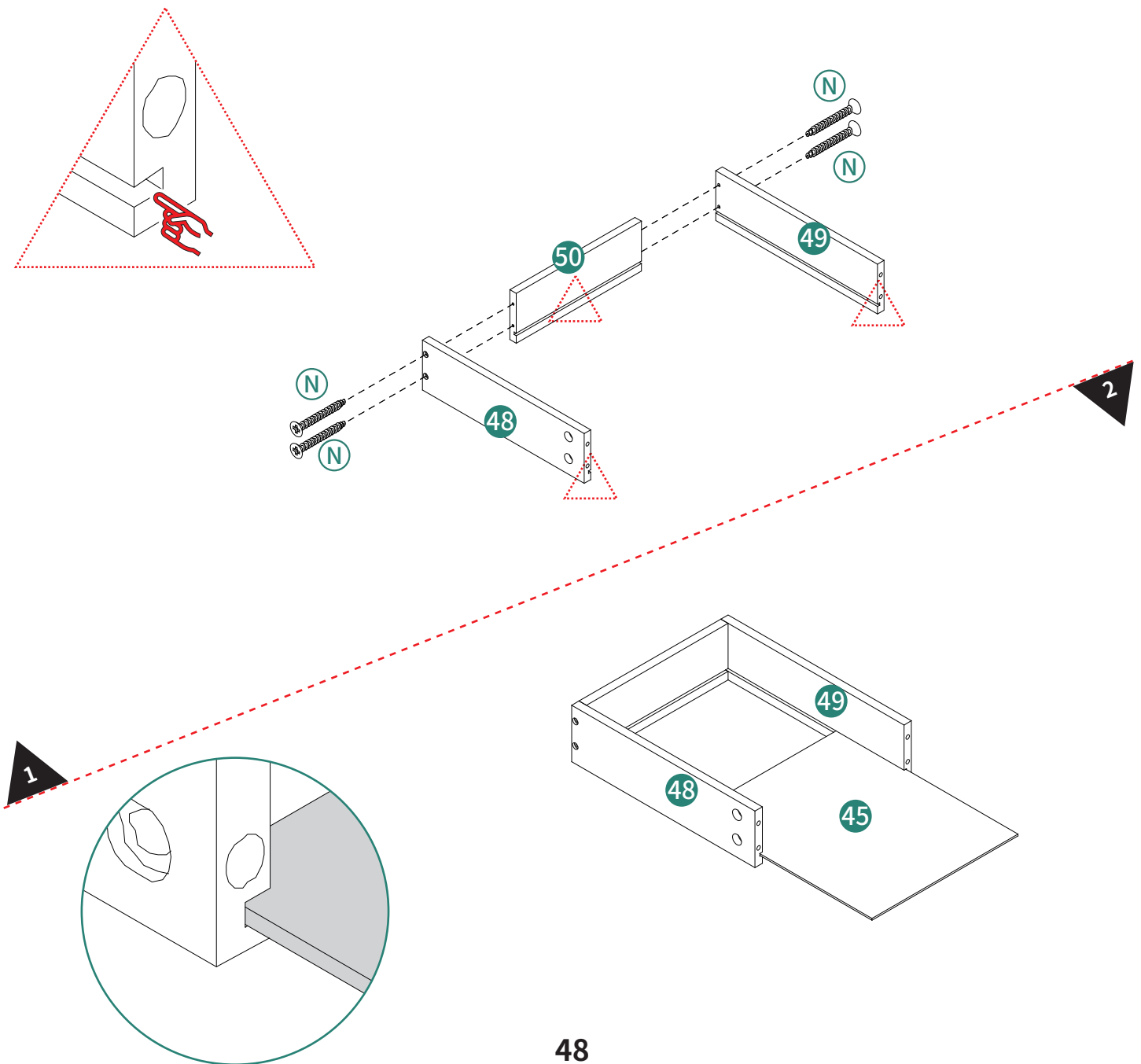

41

X4

- ④6 2pcs
- ④7 2pcs
- Ⓐ 16pcs
- Ⓑ 16pcs
- Ⓚ 4pcs

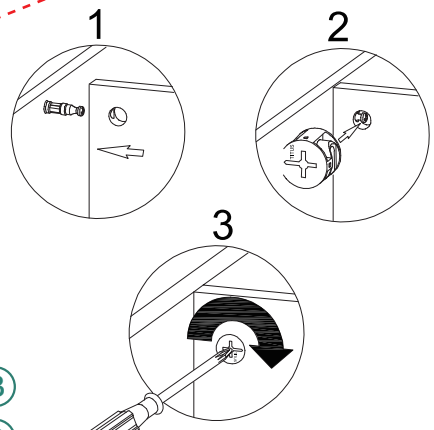
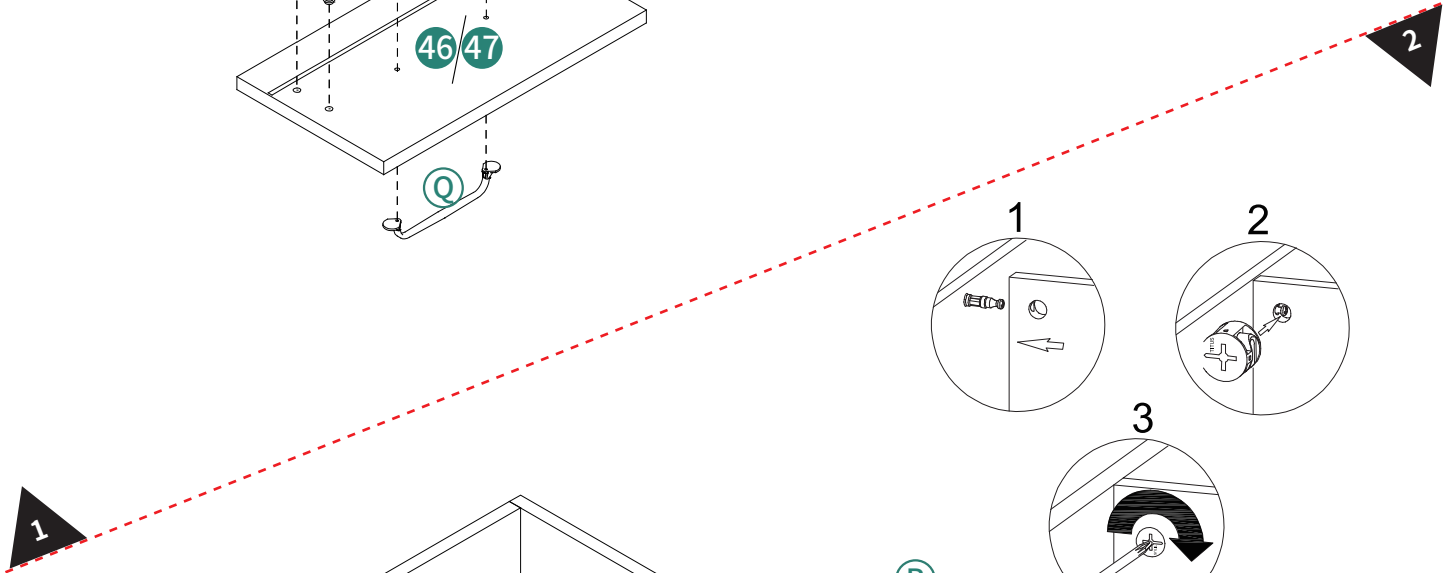
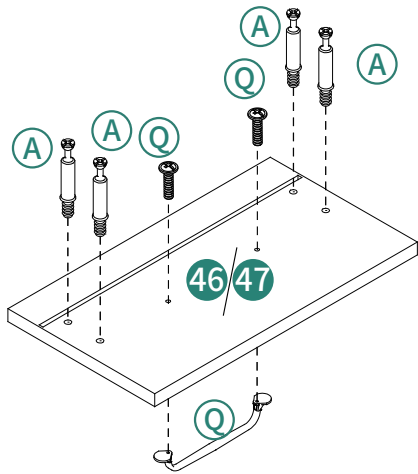

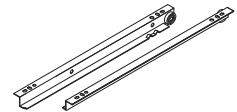
42	ST3.5X12mm		
	X4	E 16pcs	G 4pcs

Align the screws with the center of the mounting hole of the guide rail.
 Richten Sie die Schrauben mit der Mitte des Montagelochs der Führungsschiene aus.
 Alignez les vis avec le centre du trou de montage du rail de guidage.
 Allineare le viti con il centro del foro di montaggio della guida.
 Alinee los tornillos con el centro del orificio de montaje de la guía.

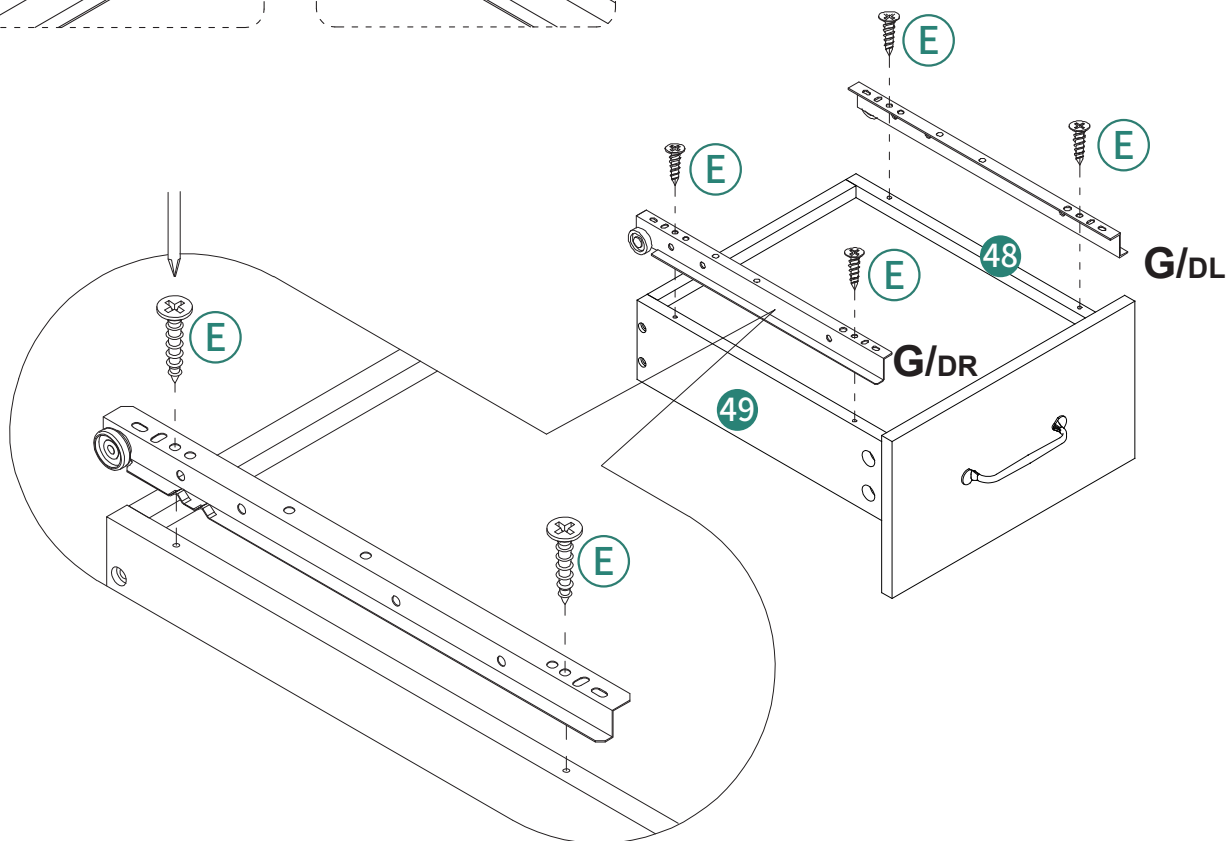
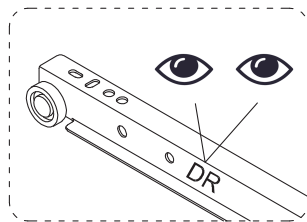
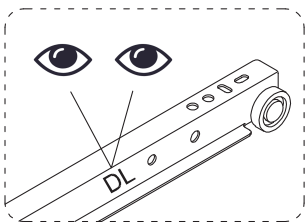

43

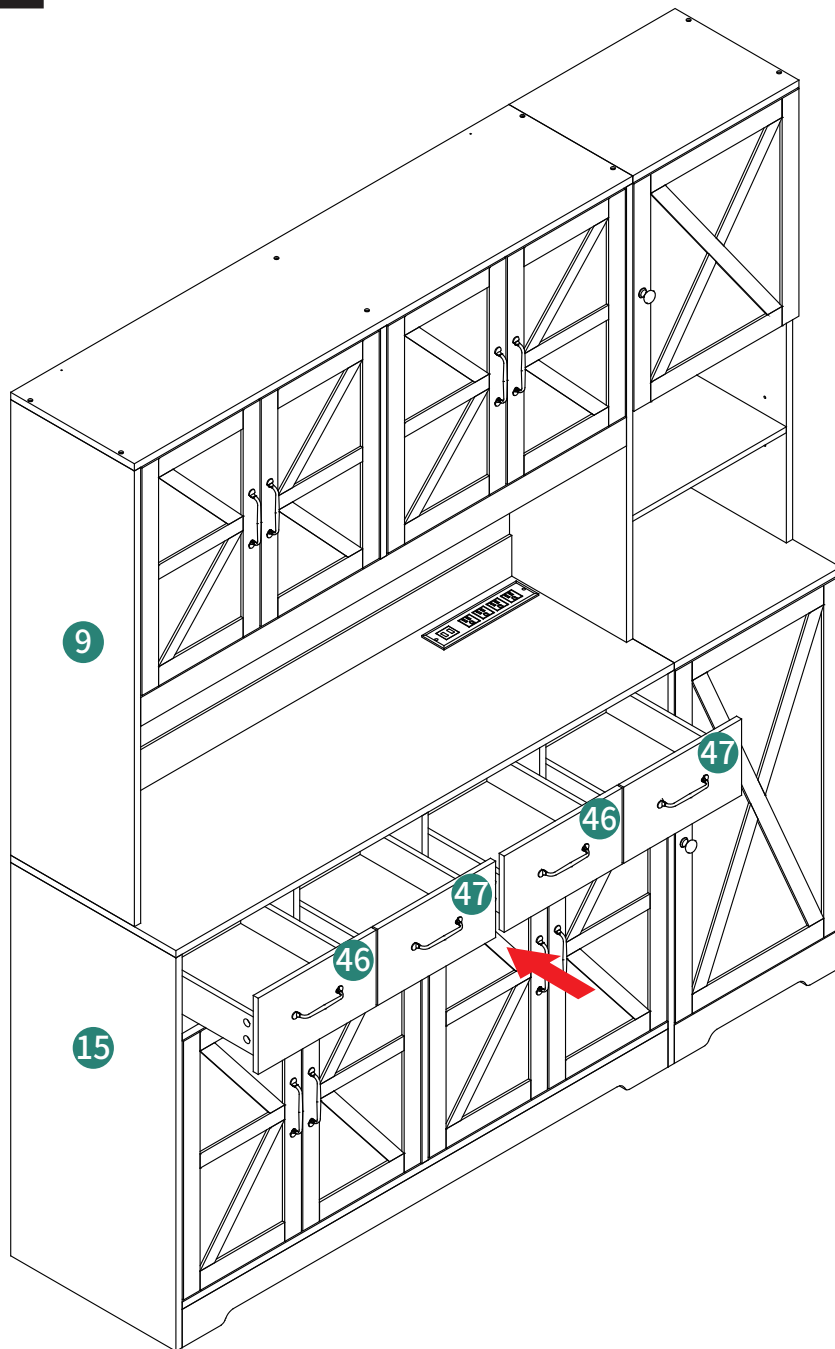

44

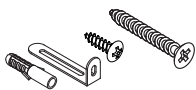

Ⓩ 2 pcs

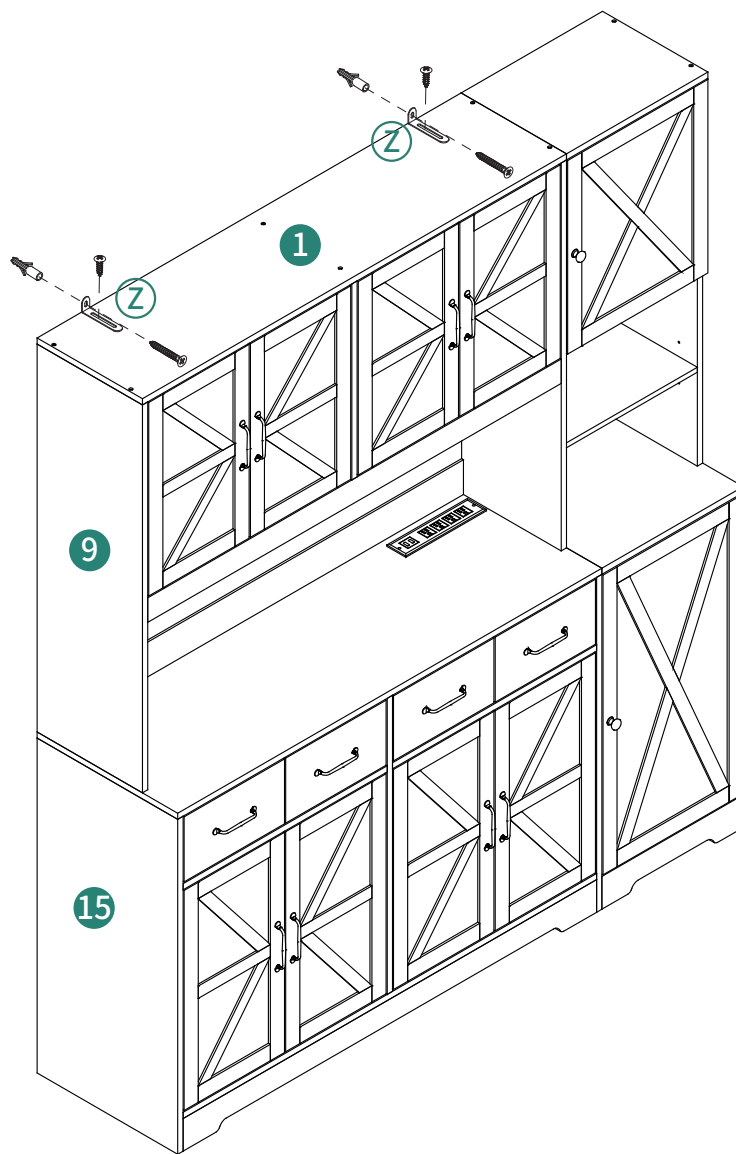
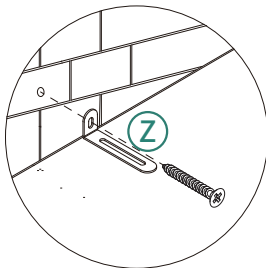
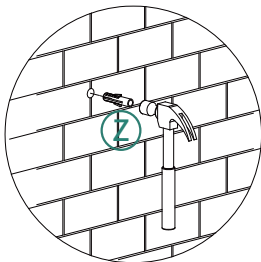
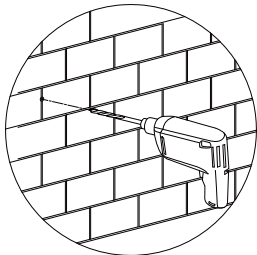
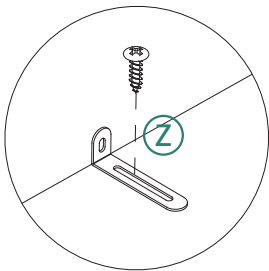

HELP CENTER



Inquiry



Assembly issue



Missing parts



Returns&Refunds

DISCLAIMER

Manufacturer and seller expressly disclaim any and all liability for personal injury, property damage or loss, whether direct, indirect, or incidental, resulting from the incorrect attachment, improper use, inadequate maintenance, unapproved modification, or neglect of this product.

Der Hersteller und Verkäufer lehnen ausdrücklich jegliche Haftung für Personenschäden, Sachschäden oder Verluste ab, egal ob direkt, indirekt oder zufällig, die durch falsche Anbringung, unsachgemäßen Gebrauch, unzureichende Wartung, nicht genehmigte Änderungen oder Vernachlässigung dieses Produkts entstehen.

El fabricante y vendedor renuncian expresamente a toda responsabilidad por lesiones personales, daños materiales o pérdidas, ya sean directos, indirectos o incidentales, derivados de la incorrecta colocación, uso inadecuado, mantenimiento insuficiente, modificación no aprobada o negligencia de este producto.

Il produttore e il venditore declinano espressamente ogni responsabilità per lesioni personali, danni materiali o perdite, dirette, indirette o incidentali, derivanti dall'errato fissaggio, uso improprio, manutenzione inadeguata, modifica non autorizzata o negligenza di questo prodotto.

Le fabricant et le vendeur déclinent expressément toute responsabilité en cas de blessures corporelles, de dommages matériels ou de pertes, qu'ils soient directs, indirects ou accessoires, résultant de la fixation incorrecte, de l'utilisation inappropriée, de l'entretien insuffisant, de la modification non approuvée ou de la négligence de ce produit.