

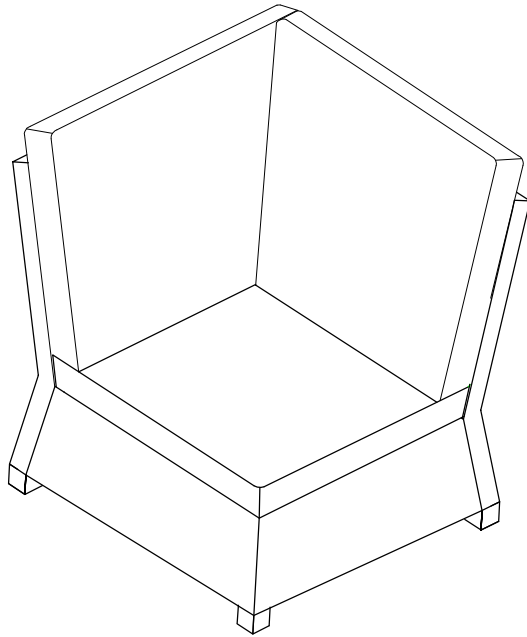

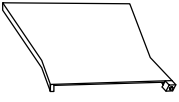

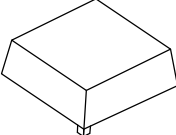

Sectional Corner Chair

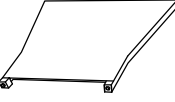



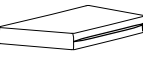

PART LIST

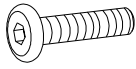
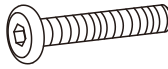
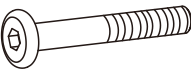

A 	B 	C 	D 	E 
Left Arm Panel 1 PC	Seat Panel 1 PC	Right Arm Panel 1 PC	Cover Of Seat Cushion * 1 PC	Core Of Seat Cushion 1 PC
F 	G 	H 	I 	
Cover Of Back Cushion * 1 PC	Core Of Back Cushion 1 PC	Cover Of Back Cushion * 1 PC	Core Of Back Cushion 1 PC	

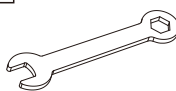
*Please note cushion covers will ship separately.

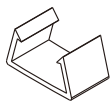
HARDWARE LIST

J 	K 	L 	M 	N 
M6*55mm Short Bolt 5 PCS	M6*65mm Medium Bolt 4 PCS	M6*95mm Long Bolt 1 PC	M6mm Nut 14 PCS	M6mm Washer 14 PCS
O 	P 	Q 		
M6mm Wrench 1 PC	M6mm Allen Key 1 PC	Plastic Clip 2 PCS		

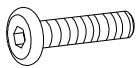
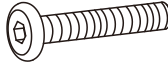
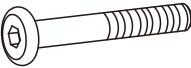
EXTRA HARDWARE LIST

J 	K 	L 	M 	N 
M6*55mm Short Bolt 1 PC	M6*65mm Medium Bolt 1 PC	M6*95mm Long Bolt 1 PC	M6mm Nut 3 PCS	M6mm Washer 3 PCS

Step 1. Lay Right Arm Panel (C) down on a flat surface. Attach Seat Panel(B) to Right Arm Panel(C) using the Short Bolts(J), Medium Bolts(K), Nuts (M), Washers(N), Wrench(O) & Allen Key (P).

NOTE: Please do not fully tighten bolts until unit is fully assembled.

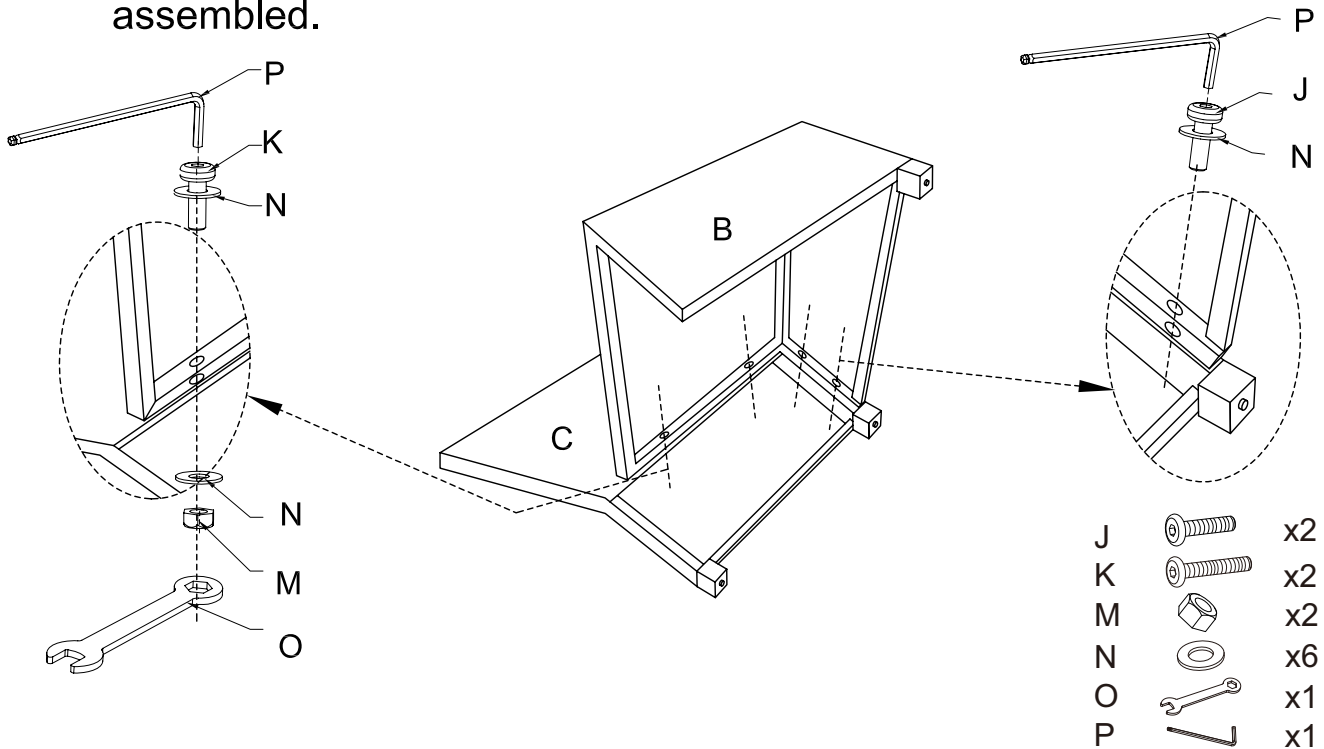

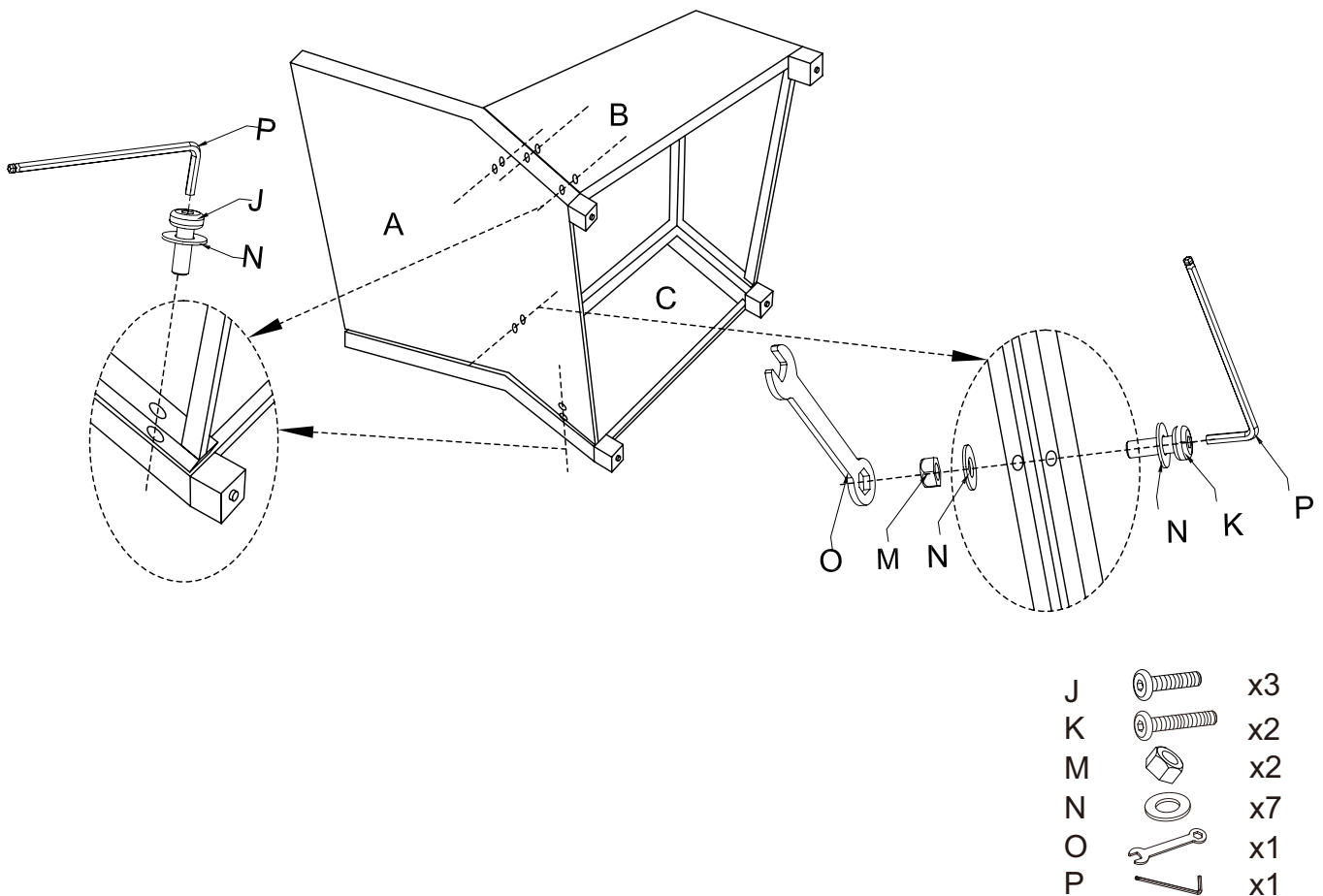

Step 2. Attach Left Arm Panel(A) to Right Arm Panel(C) and Seat Panel (B) using the Short Bolts(J), Medium Bolts(K), Washers(N), Nuts(M), Wrench (O) & Allen Key (P).

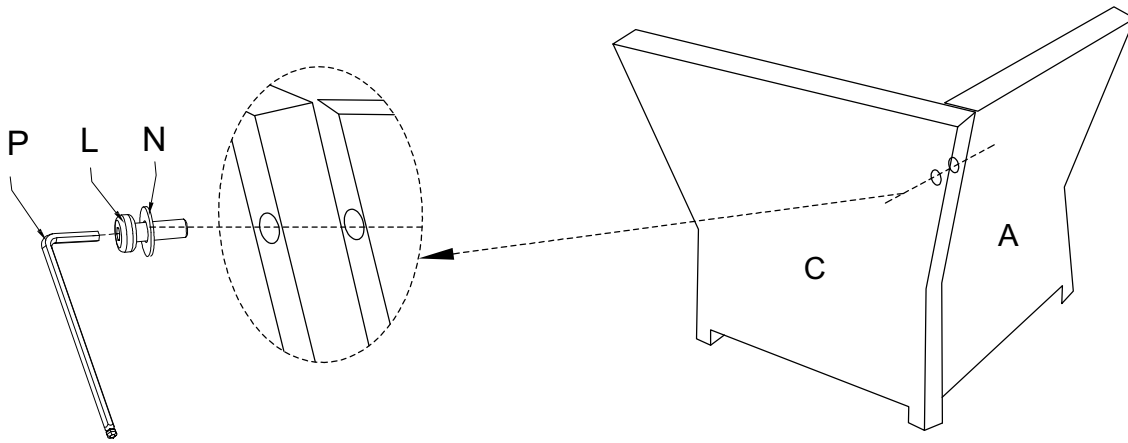

Step 3. Attach Right Arm Panel(C) to Left Arm Panel(A) using the Long Bolts(L),Washers(N) & Allen Key (P).



- | | | |
|---|---|----|
| L |  | x1 |
| N |  | x1 |
| P |  | x1 |

Step 4. Insert Core Of Seat Cushion (E) into Cover Of Seat Cushion (D).
 Insert Core Of Back Cushion (G) into Cover Of Back Cushion (F).
 Insert Core Of Back Cushion (I) into Cover Of Back Cushion (H).

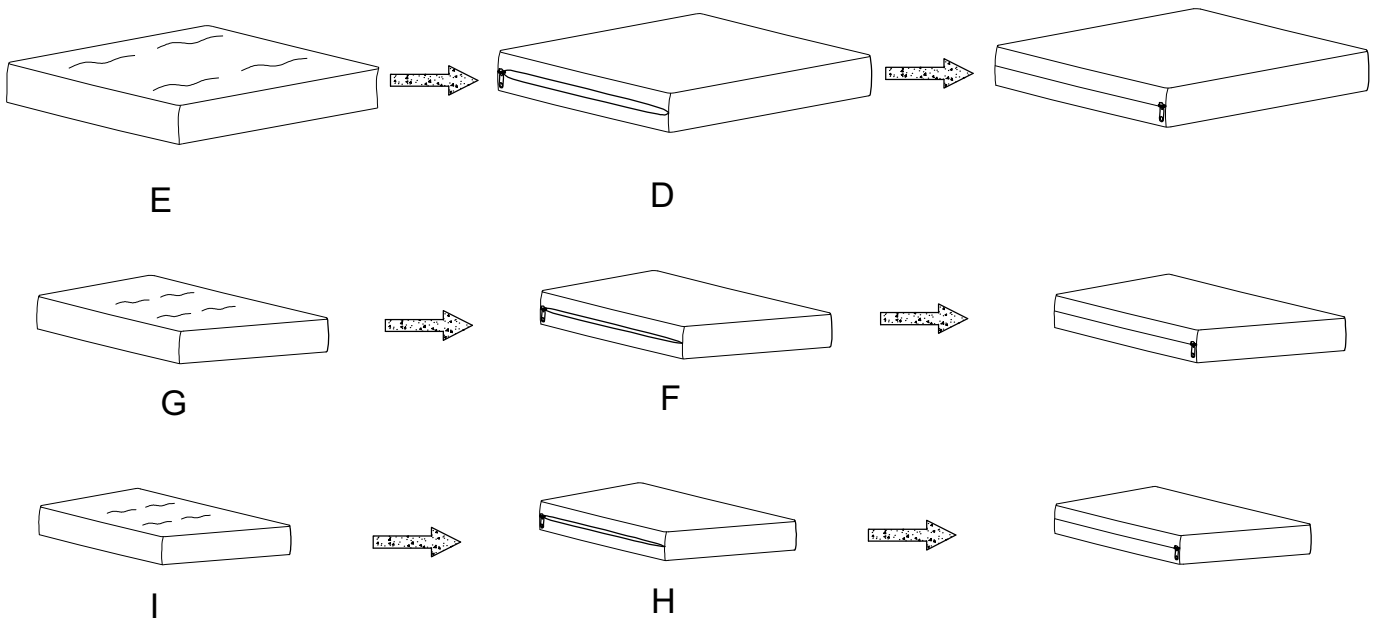

Step 5. Place Seat Cushion and Back Cushion on the chair.

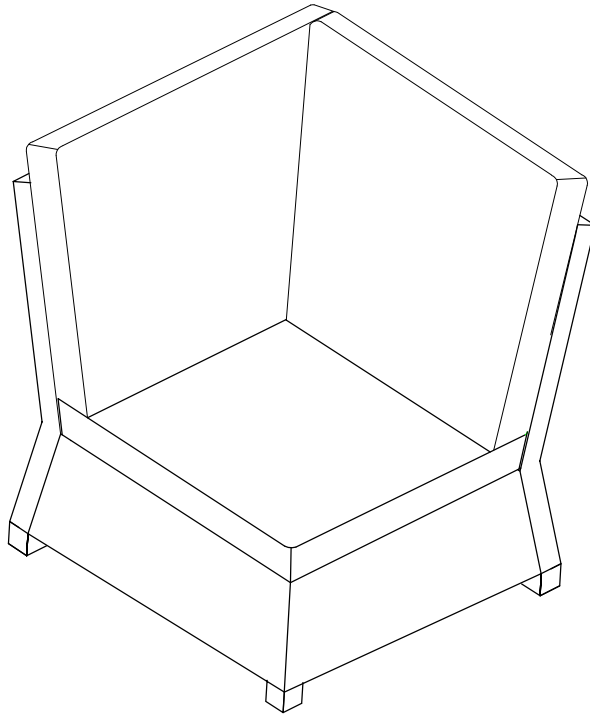

Step 6. Use plastic clips (part Q) to secure additional units together as shown.

