

Installation Manual

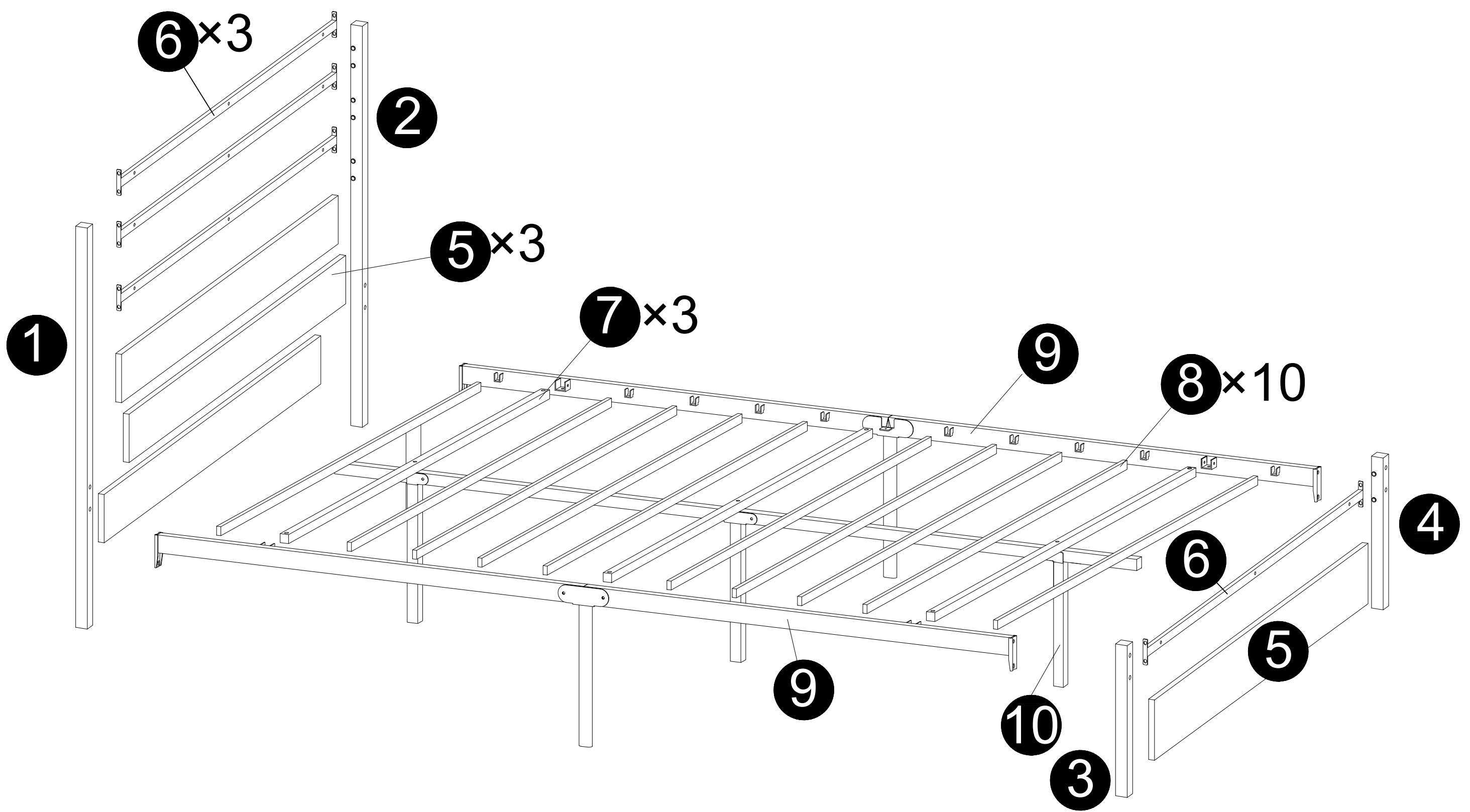

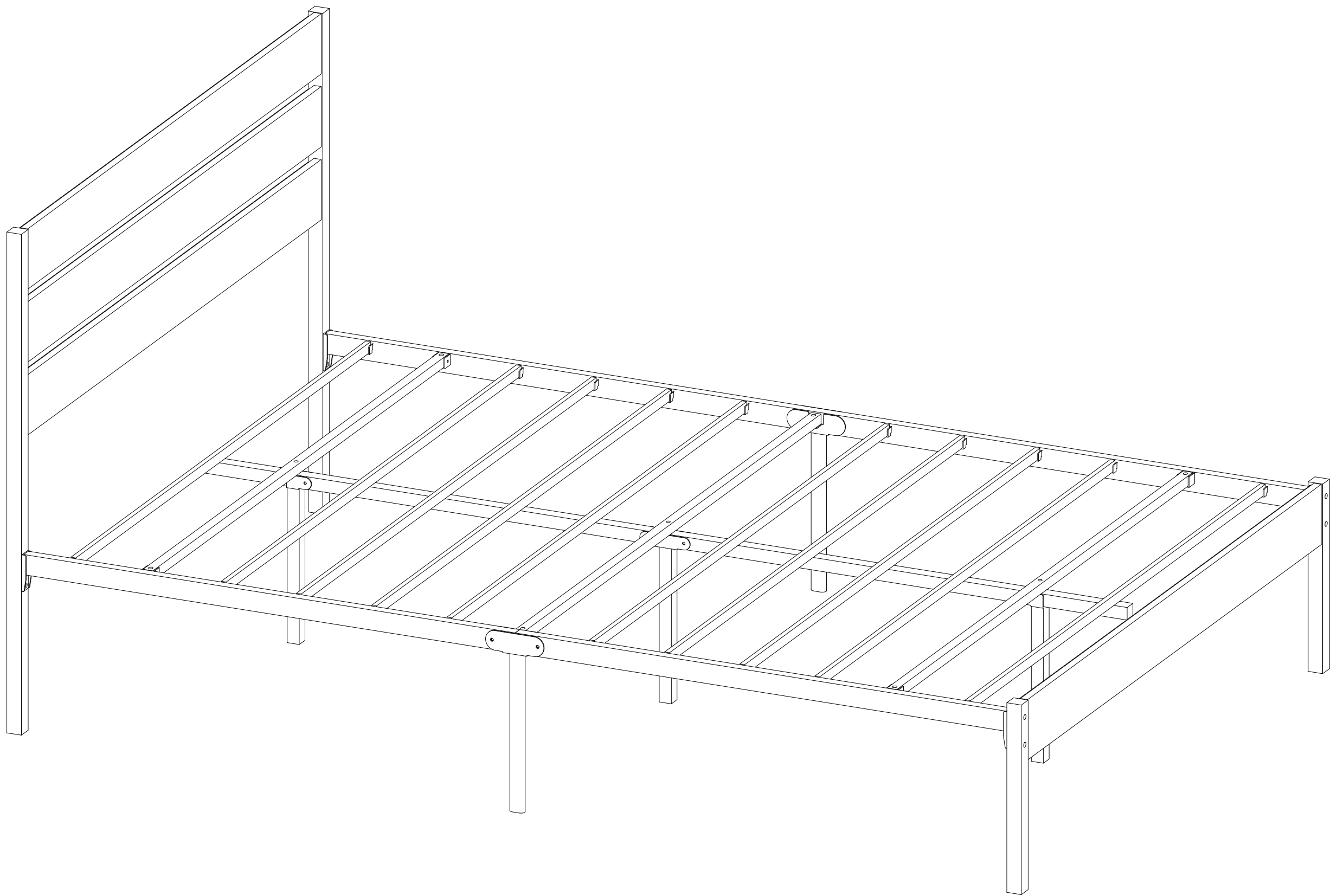

① × 1pc

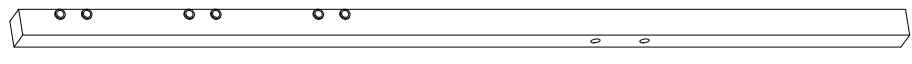
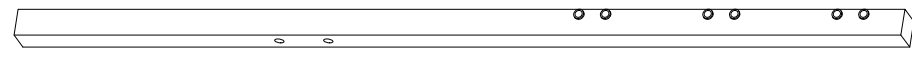

② × 1pc

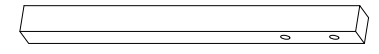

③ × 1pc

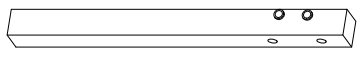

④ × 1pc

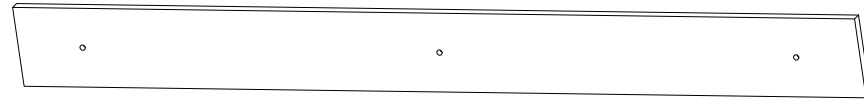

⑤ × 4pcs

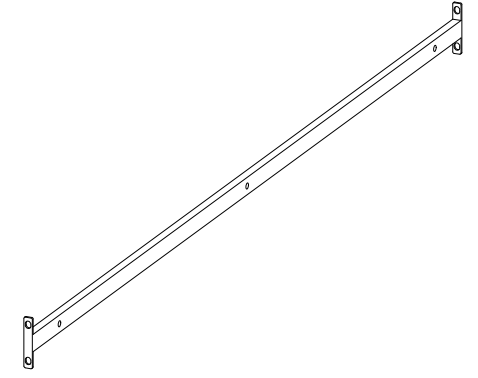

⑥ × 4pcs



⑦ × 3pcs



⑧ × 10pcs

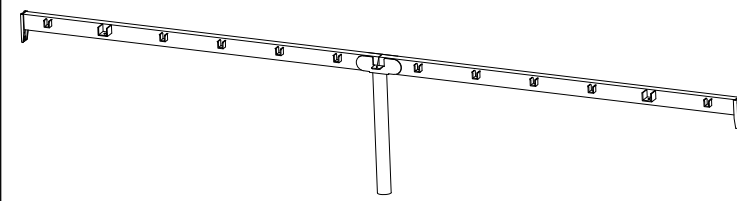

⑨ × 2pcs

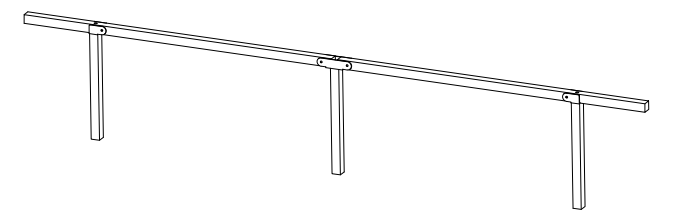

⑩ × 1pc

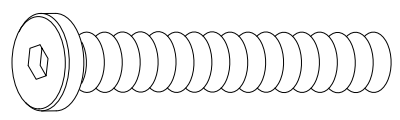

M8×50mm

① × 4pcs

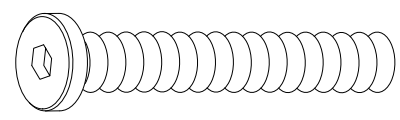

M6×55mm

② × 3pcs

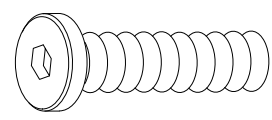

M6×25mm

③ × 4pcs

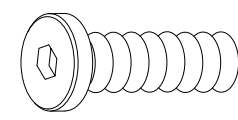

M6×20mm

④ × 12pcs

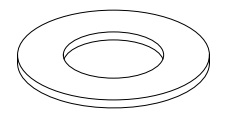

⑤ × 8pcs

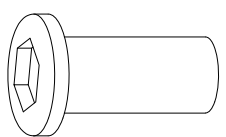

M6×12mm

⑥ × 4pcs

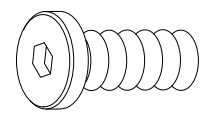

⑦ × 16pcs



⑧ × 2pcs

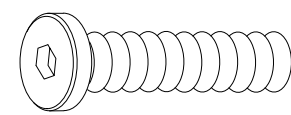

M6×30mm

⑨ × 6pcs

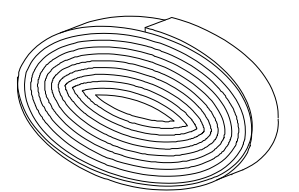

⑩ × 1pc

1

Note: For easy setup intention,
do not tighten screws during
the installation process

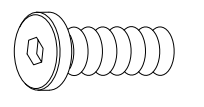

M6×12mm

G × 16pcs

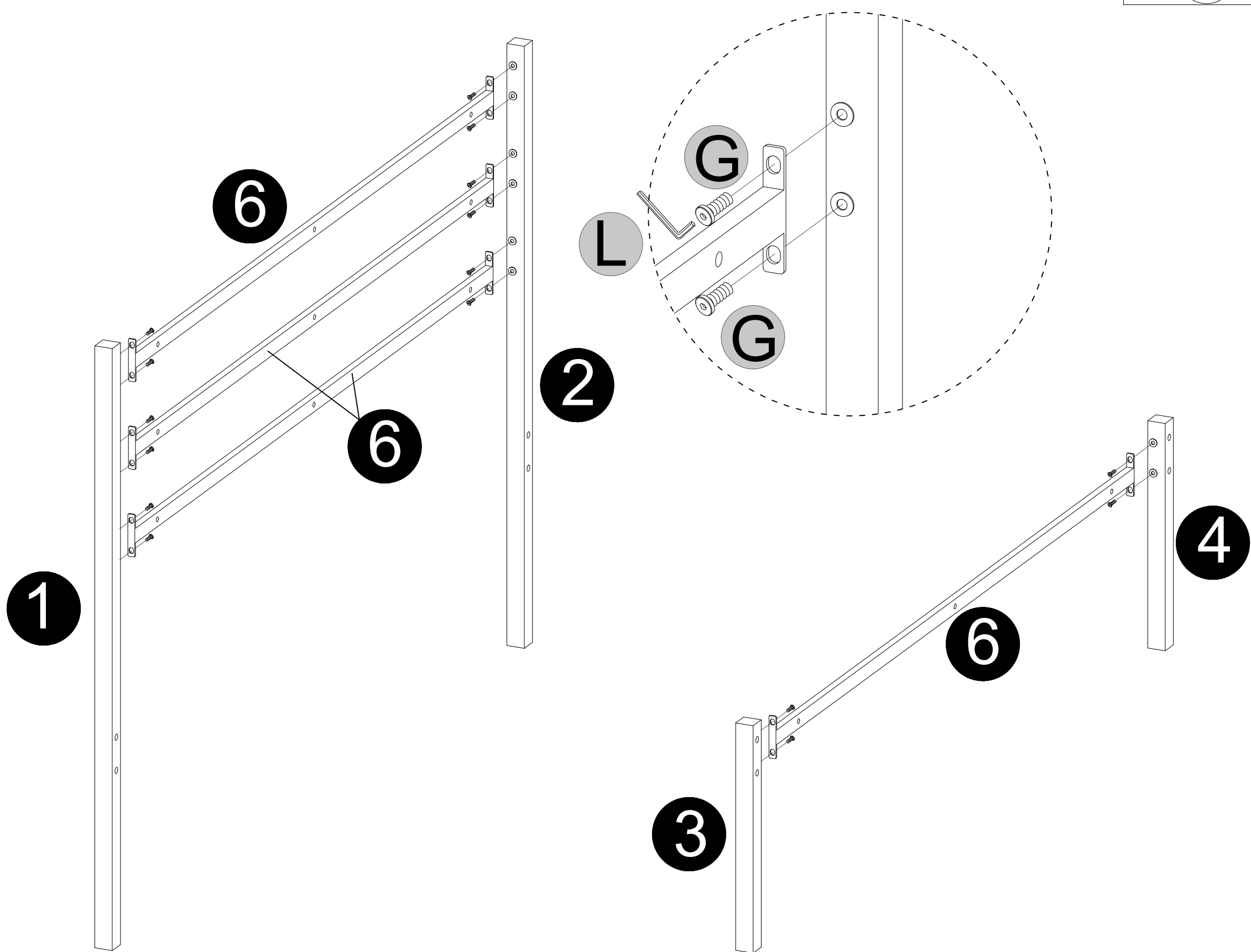

2

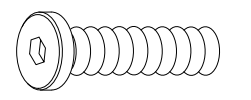

M6×20mm

D × 12pcs

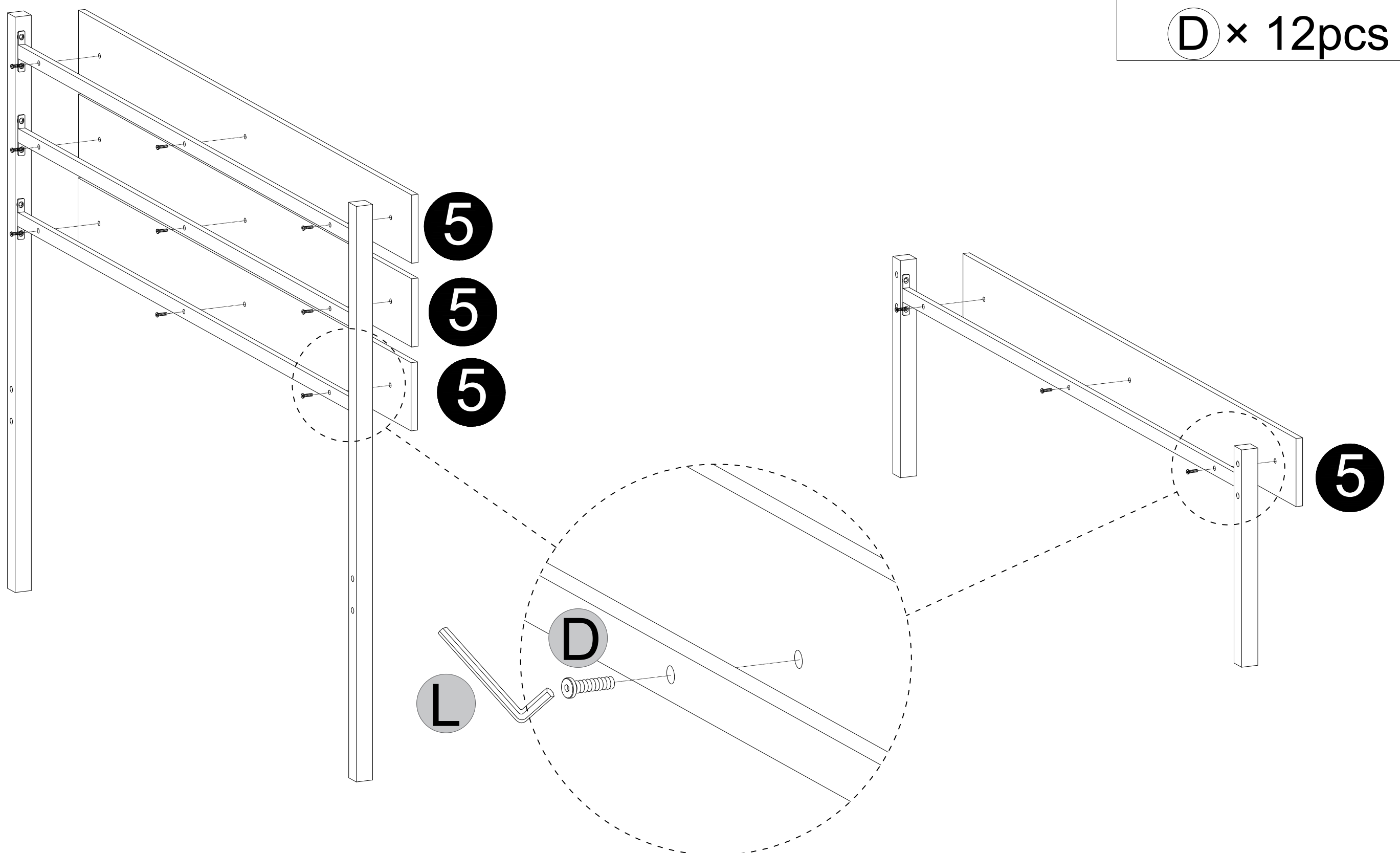

3

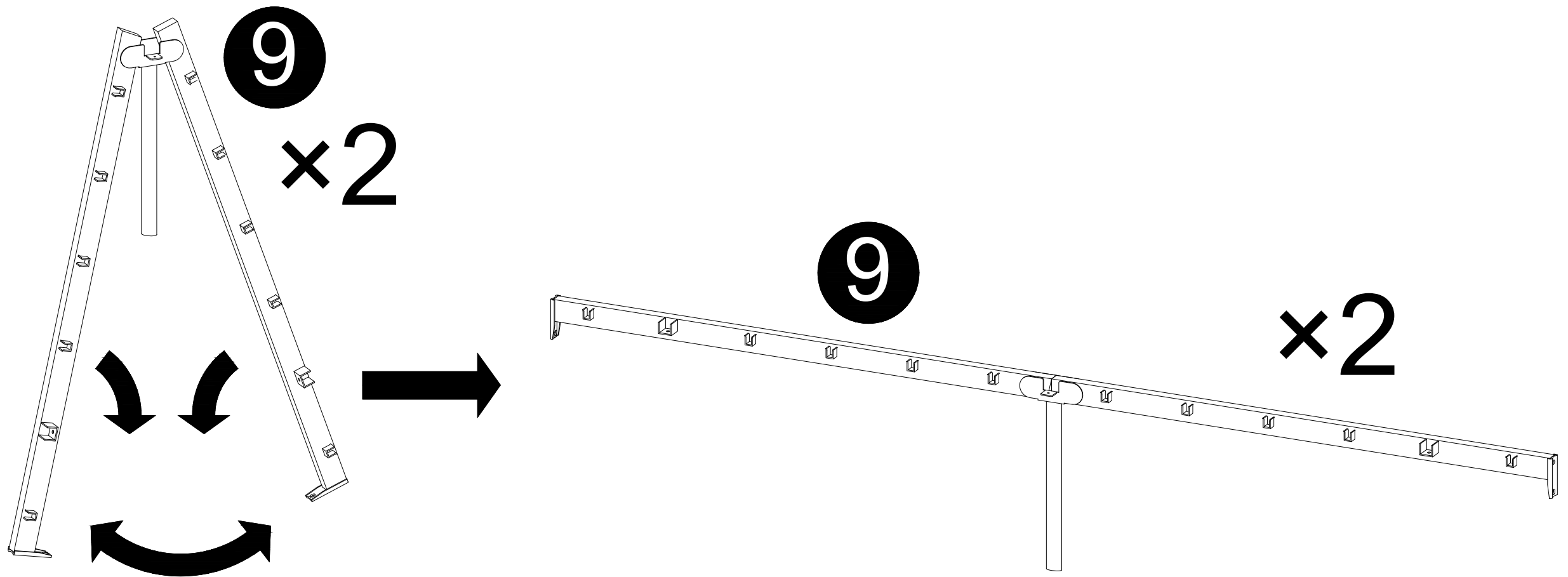

4

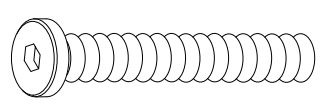

M8x50mm

A x 4pcs

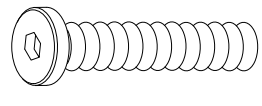

M6x25mm

C x 4pcs

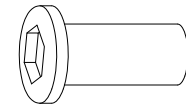

F x 4pcs

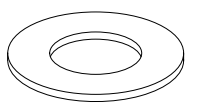

E x 8pcs

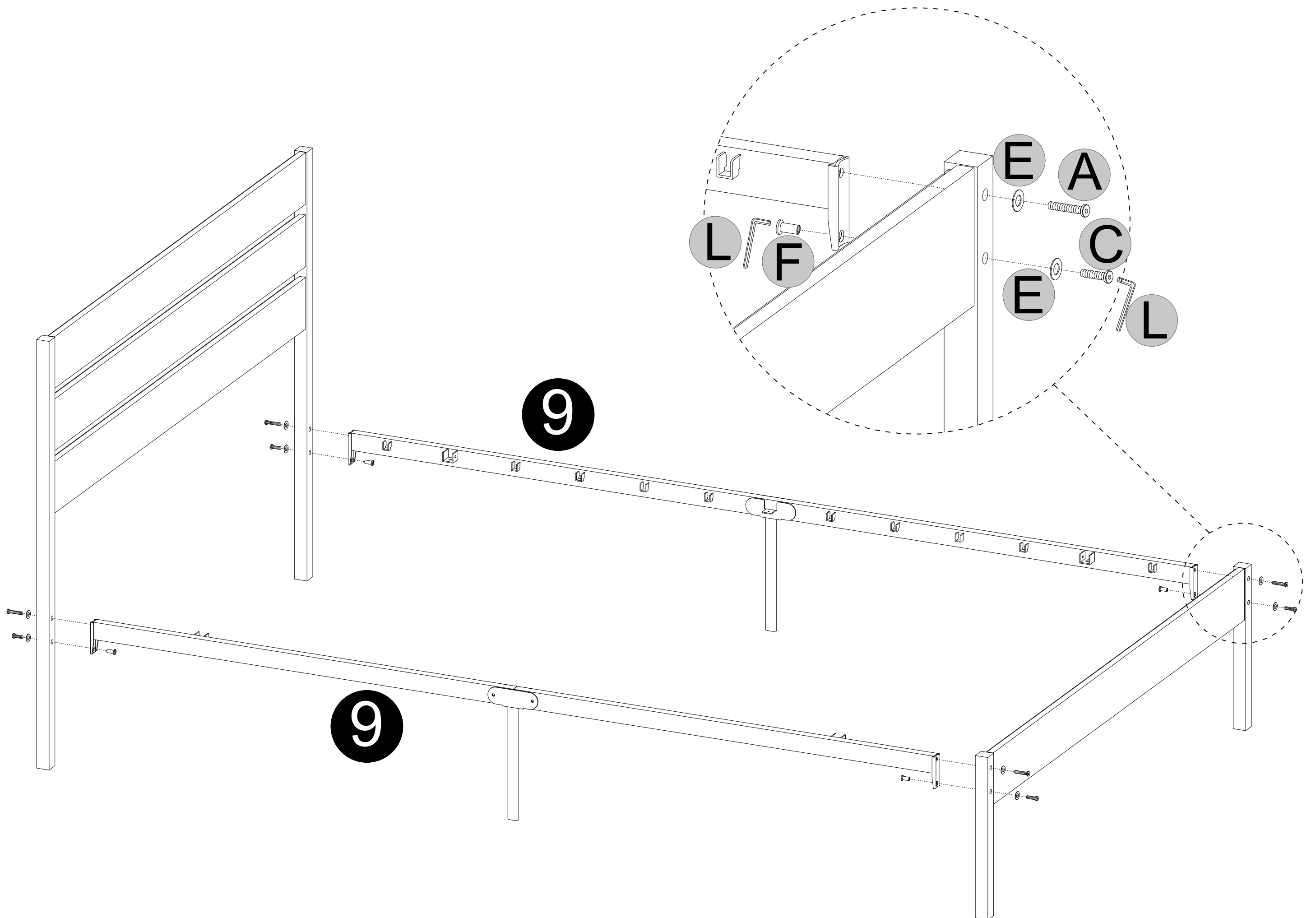

5

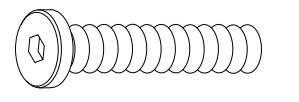

M6×30mm

M × 6pcs

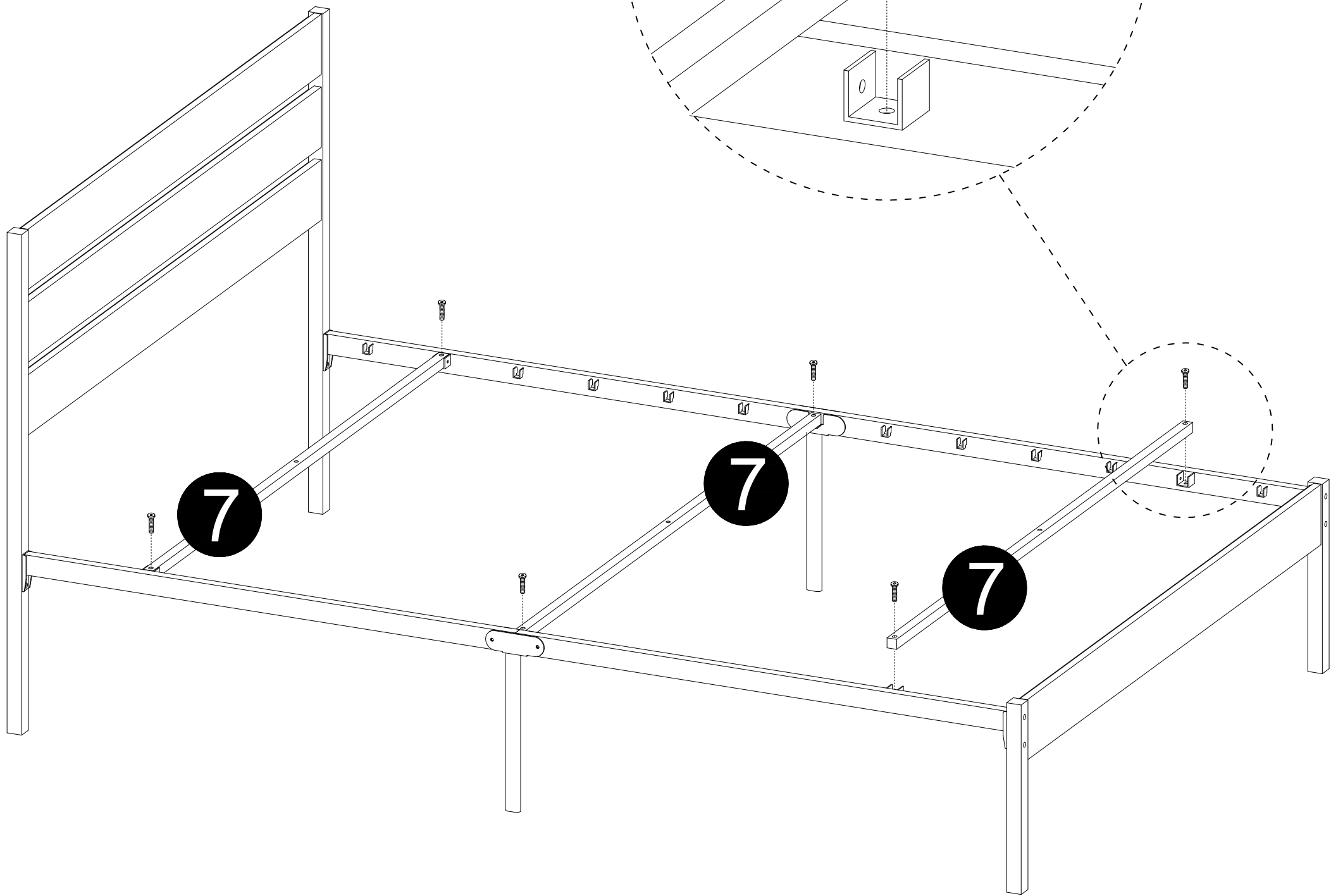
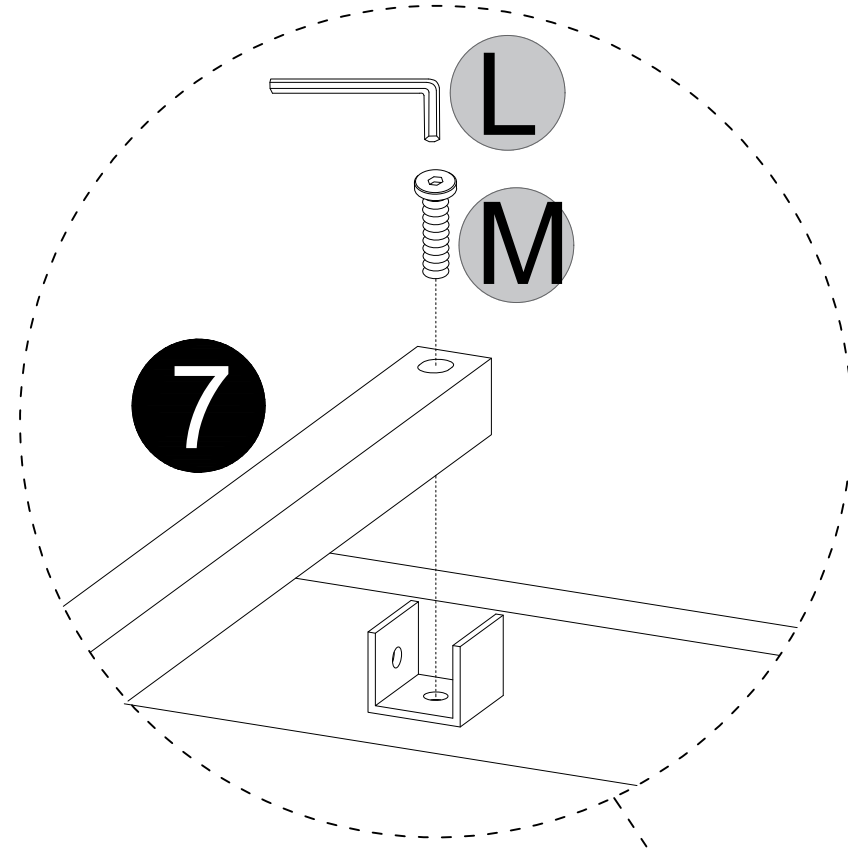

6

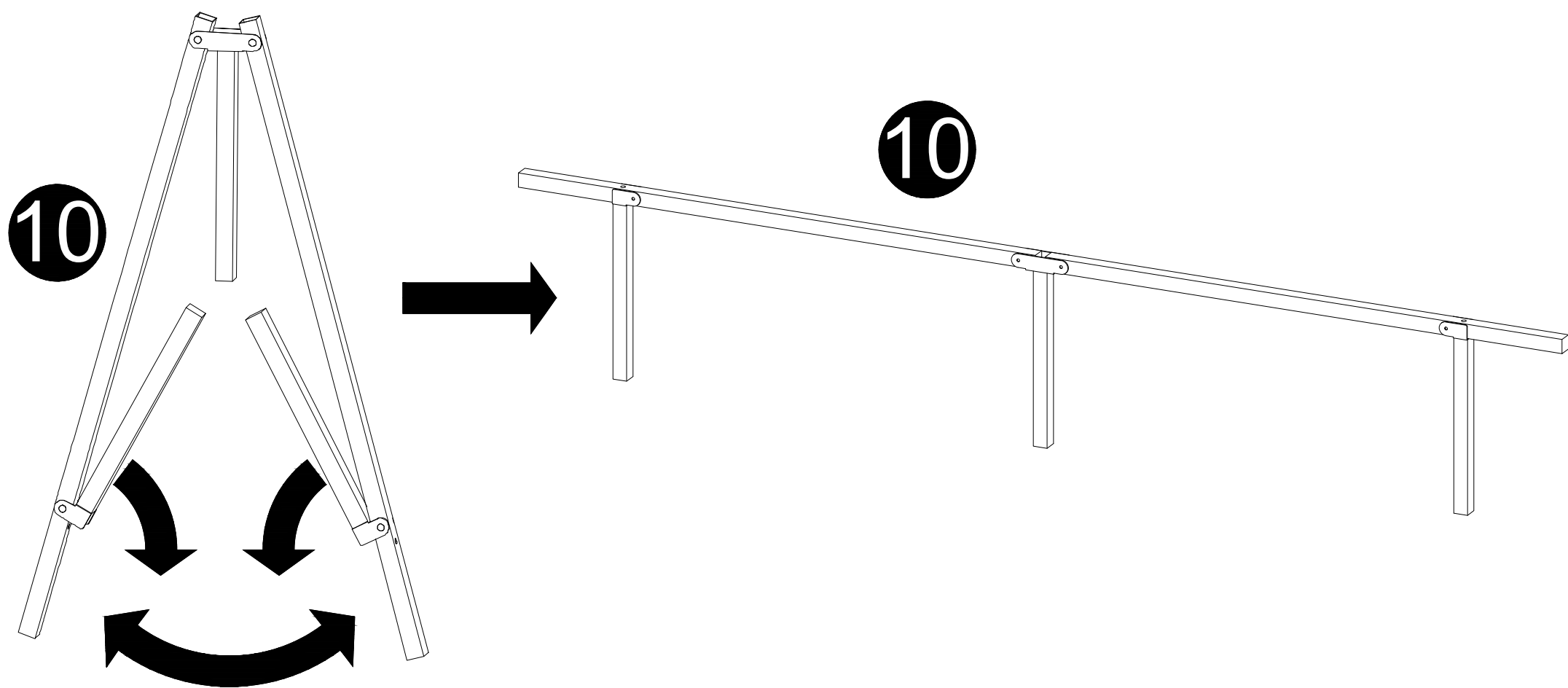

7

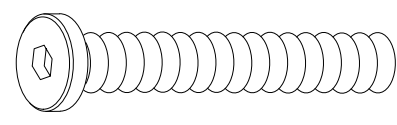

M6×55mm

B × 3pcs

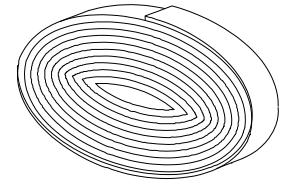

N × 1pc

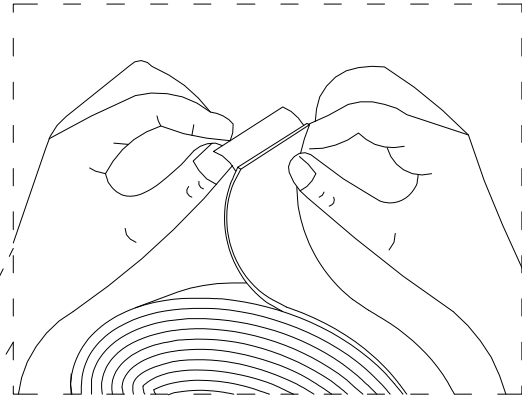

step2.To prevent friction noise, unroll part N and fit it on part 10 ,the lenght of part N can cut as you will.

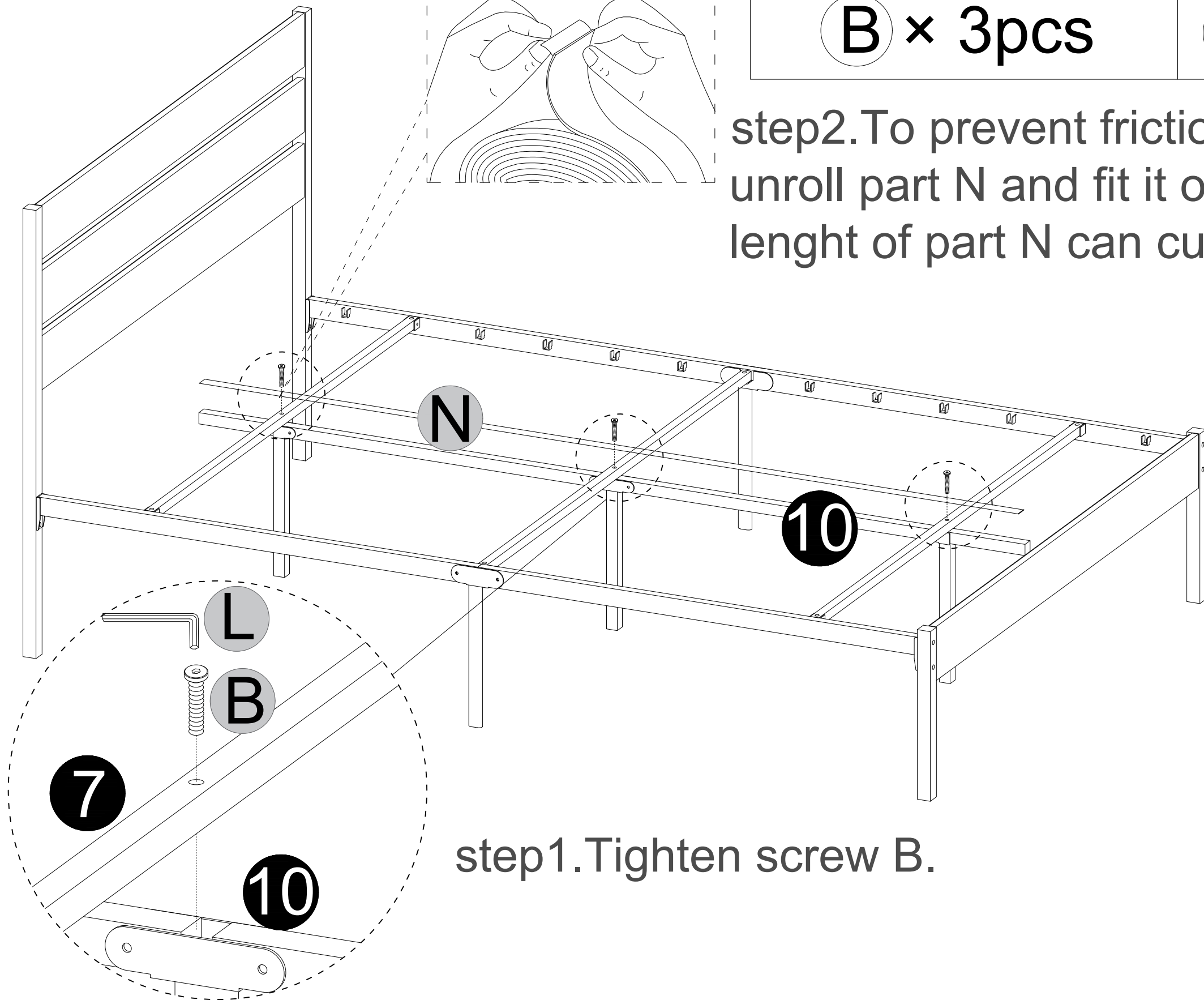

step1.Tighten screw B.

8

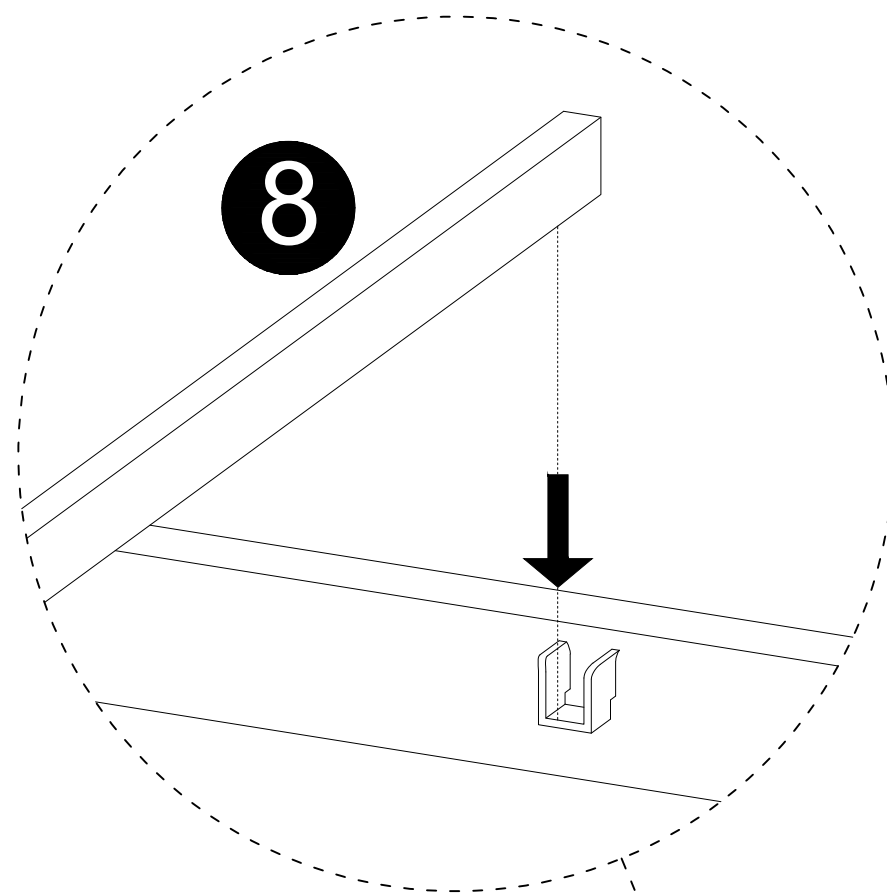

×10

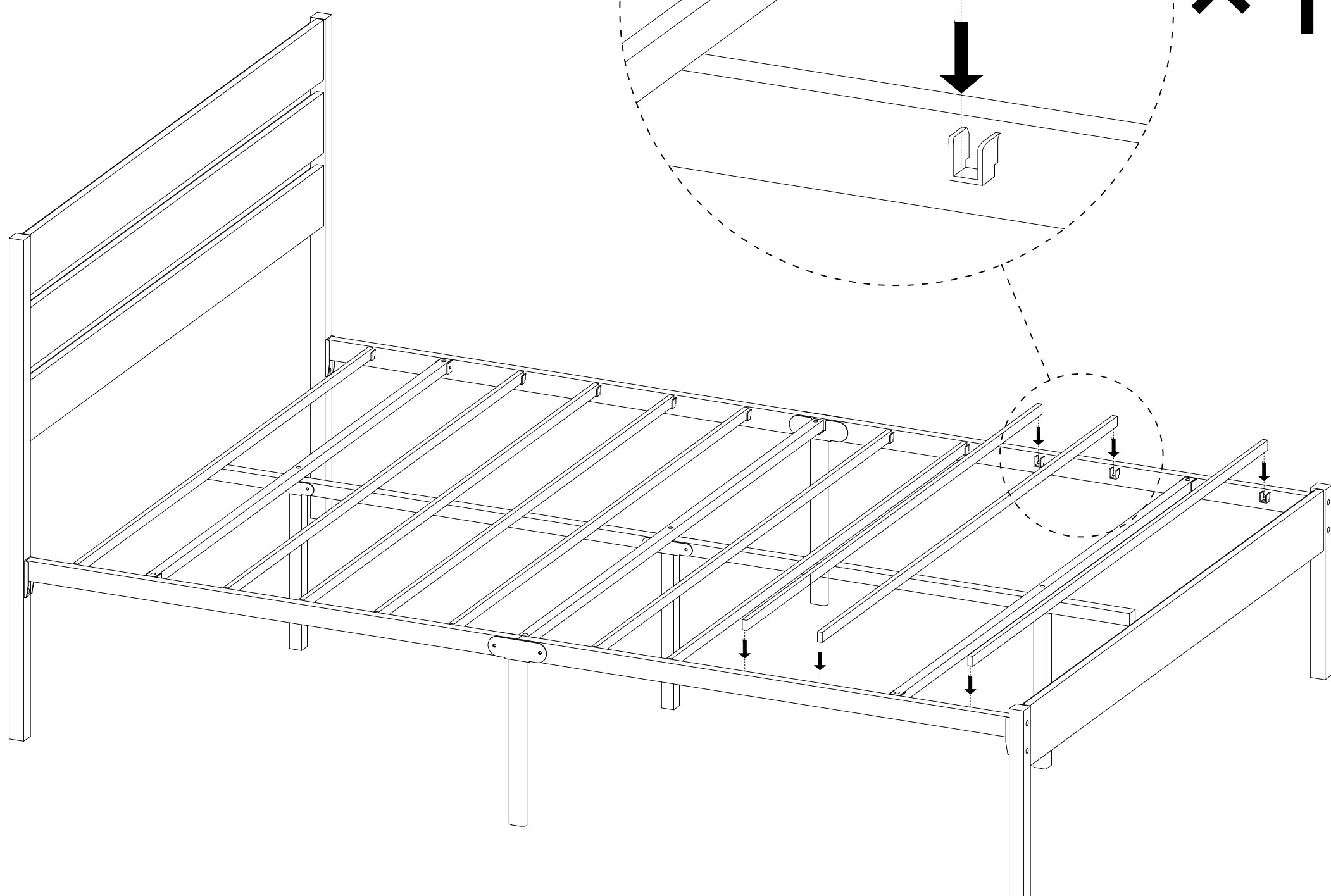

9

Check and tighten all screws

