

Assembly Instructions

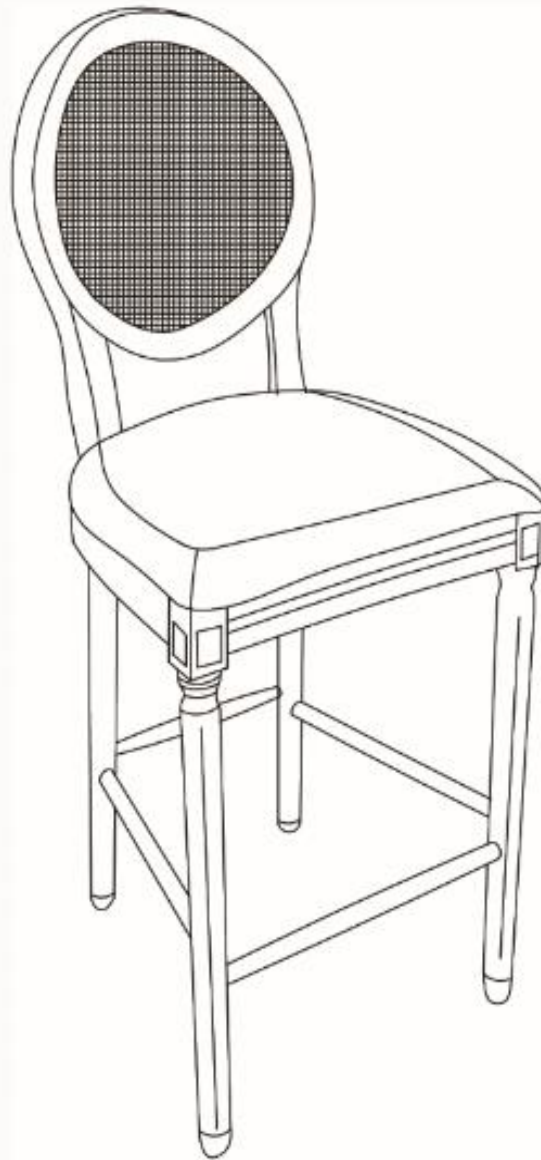



Caution: Please read this carefully before you proceed

Please look in the Chair Back for hardware packs.



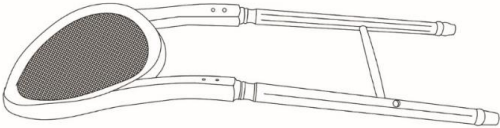
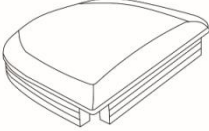



Bar Stool



Part List

Label	Picture	Description	QTY
A		Chair Back	1
B		Chair Seat	1
C		Left Chair Leg	1
D		Right Chair Leg	1
E		Front Stretcher	1
F		Side Stretcher	2

Hardware

Label	Picture	Description	QTY
①		Bolt (M8x60mm)	9
②		Screw (M4x38mm)	7
③		Spring Washer	9
④		Washer	9
⑤		Allen Key	1
⑥		Screwdriver	1

Assembly Preparation

Before Beginning Assembly:

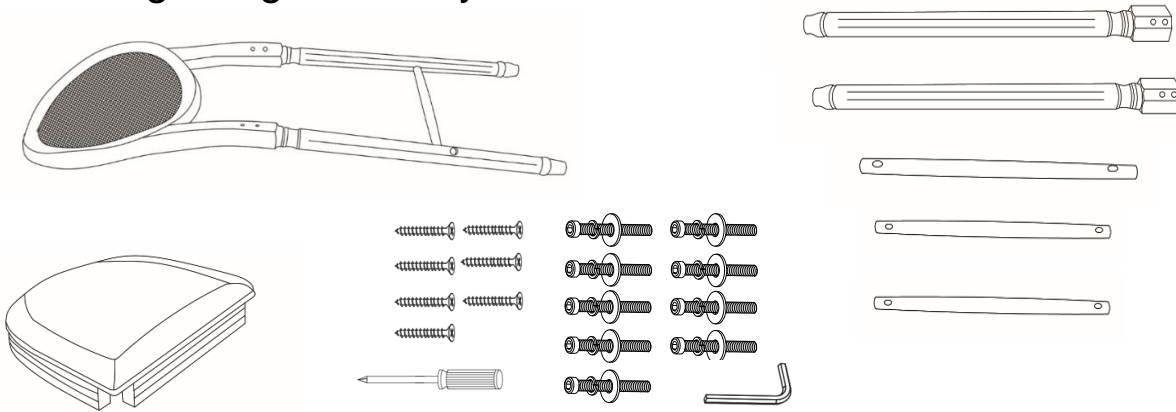

- Read instructions, cover to cover-



- Have 2 adults on hand for assembly-



- Do not assemble on flooring or carpet-



- Assemble on a clean non-marring surface (packing foam)-



- Save all packaging until finished-

Assembly Steps

Overview

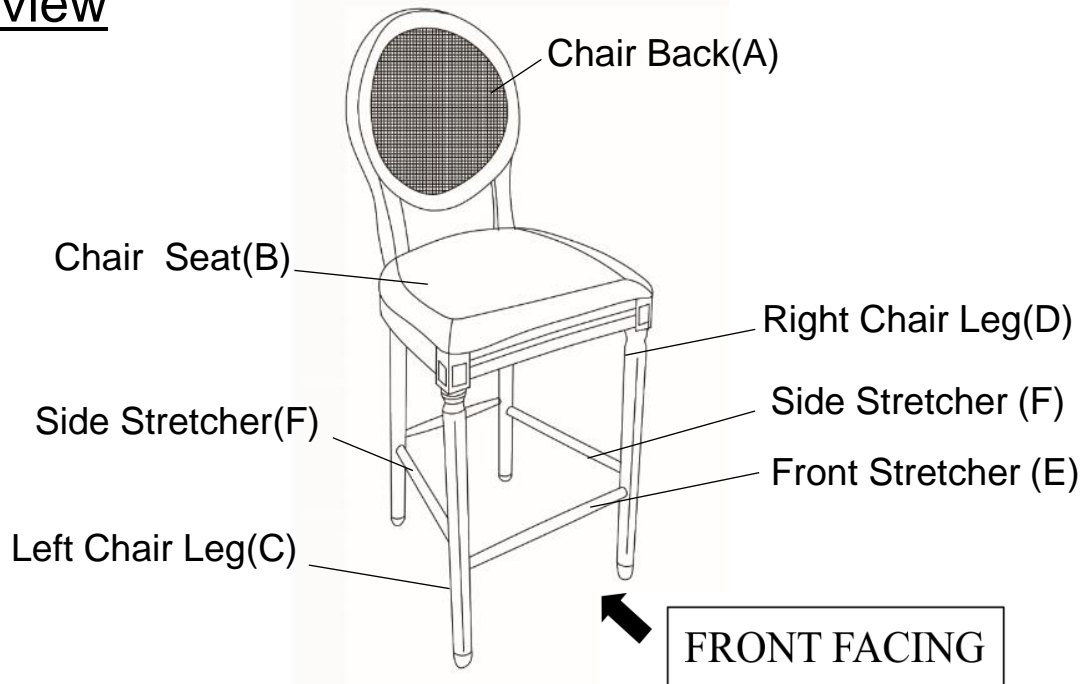

This Bar Stool has multiple parts and may require up to 30 minutes to assemble. To give you an overview of the Bar Stool parts, the above picture is provided to help you put the various parts into perspective. Please read through the instructions below to familiarise yourself with the parts and steps before assembly.

Step 1

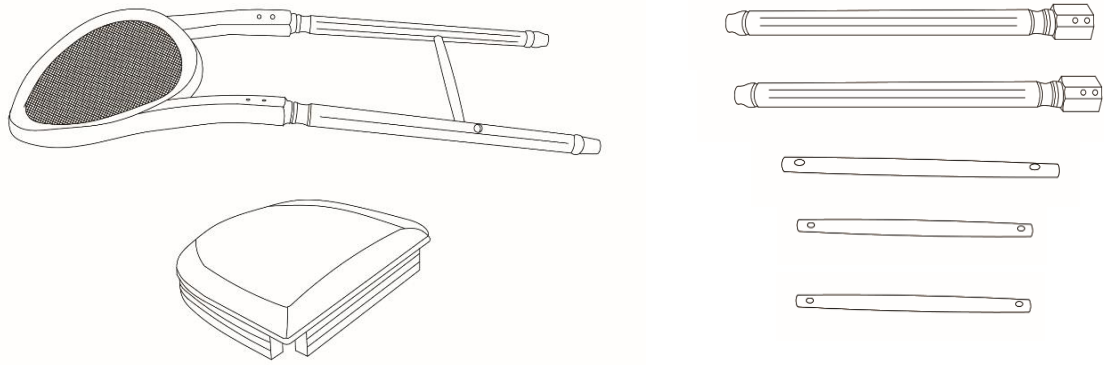

Place the Chair Back(A), the Chair Seat(B), the Left Chair Leg(C), the Right Chair Leg(D), the Front Stretcher(E), the Left Stretcher(F) and the Right Stretcher(G) onto a clean, non-marring surface.

Step 2

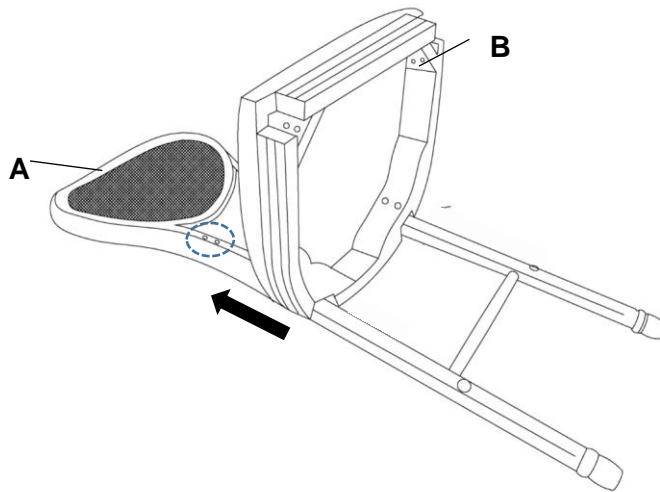

Attach the two slots on the Chair Seat(B) to the lower legs on the Chair Back(A), then push the Chair Seat(B) upward to align it with the mounting positions on legs.

Step 3

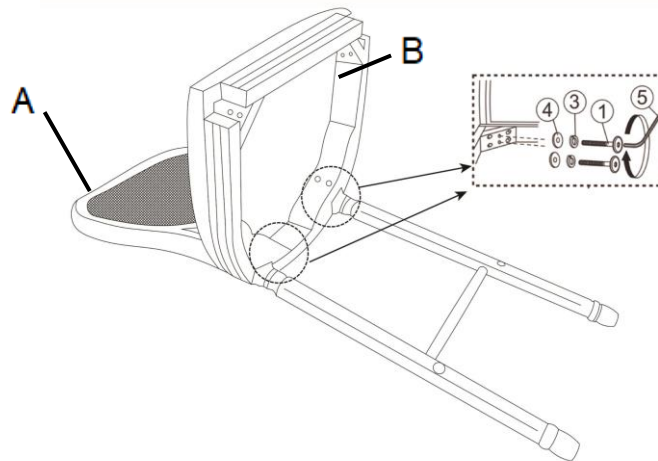

With assistance from a second adult, attach the Chair Seat(B) to the Chair Back(A) using Bolts(①), Spring Washers(③) and Washers(④) with the Allen Key(⑤).

Do not fully tighten the bolts.

Step 4

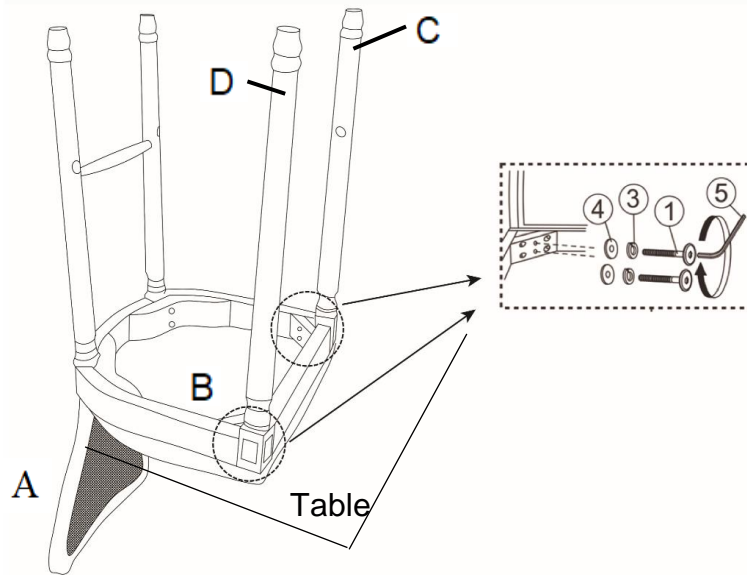

Place the assembled Chair Back(A) and the Chair Seat(B) downward on a clean, non-marring table. Attach the Left Chair Leg(C) to the Chair Seat(B) using Bolts(①), Spring Washers(③) and Washers(④) with the Allen Key(⑤).

Repeat the same step to attach the Right Chair Leg(D) to the Chair Seat(B).

Do not fully tighten the bolts.

Step 5

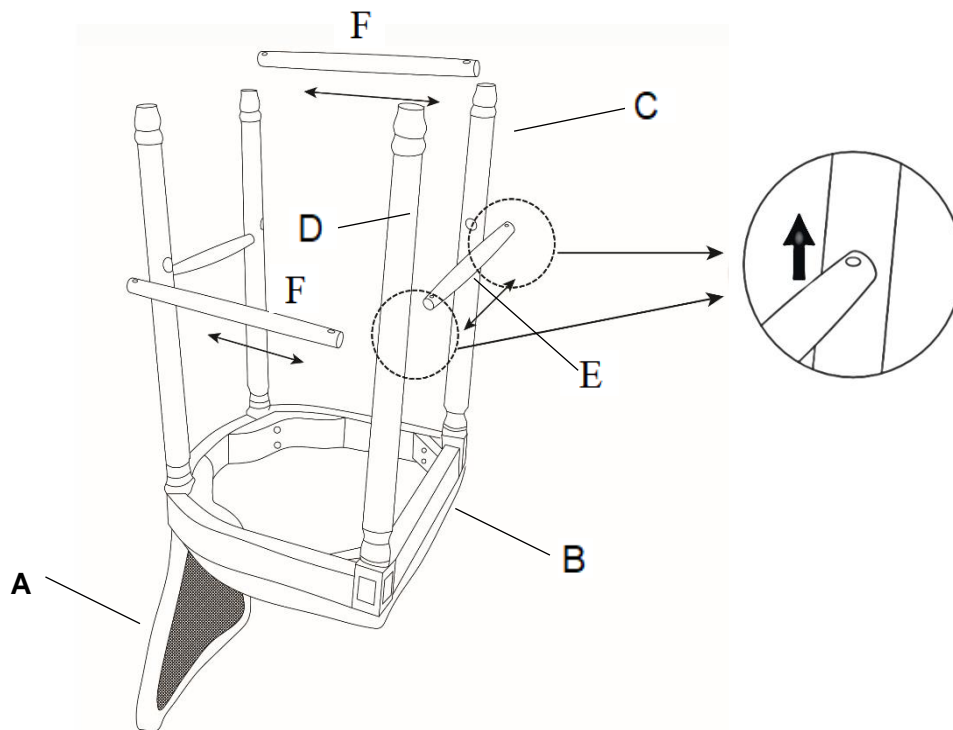

Insert the Side Stretchers(F) and the Front Stretcher(E) into the mounting positions between the legs in sequence.

Note: You may need to apply a little pressure to the Stool Legs to enable the Stretcher to be slotted into position.

Please ensure that all the drill holes on the Stretcher are facing upwards as shown in the figure.

Step 6

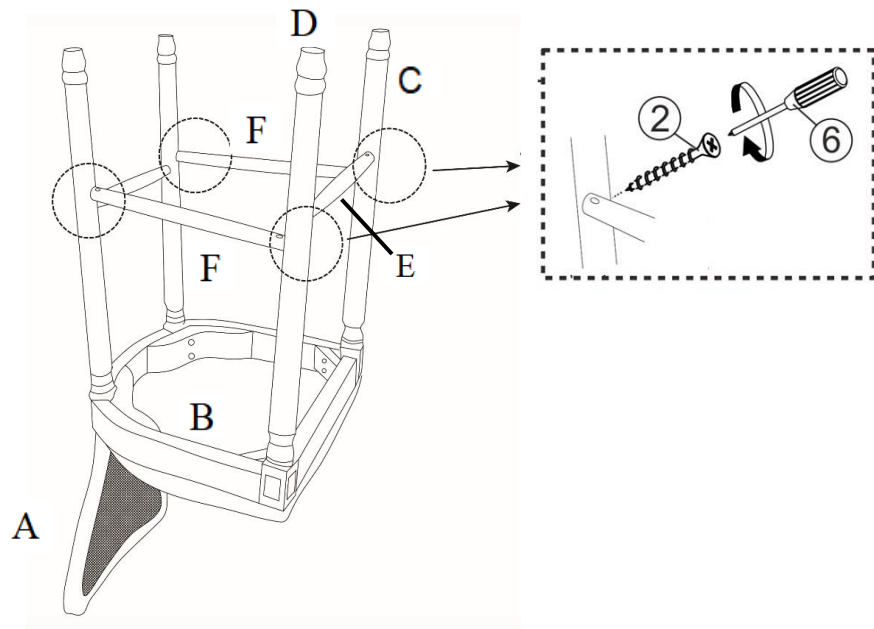

Attach all the Stretchers using Screws(②) with the Screwdriver(⑥).

Step 7

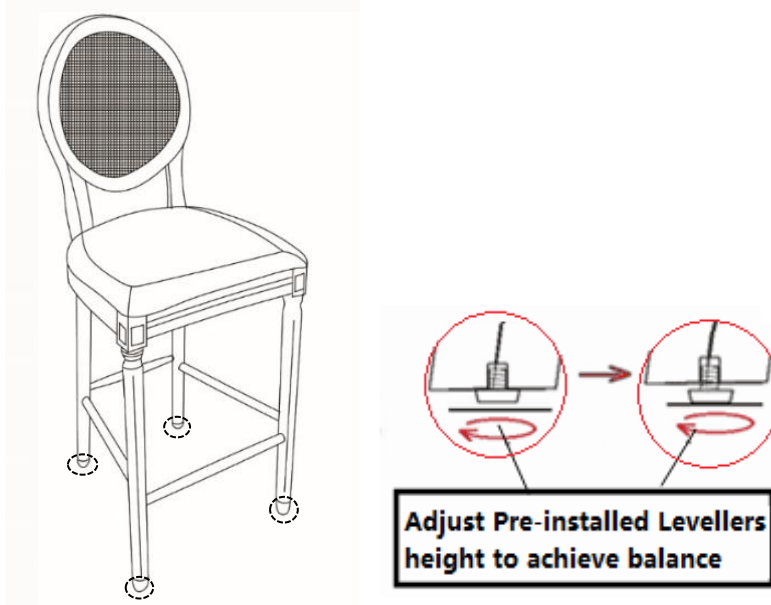

Stand the Barstool up.

Check the stability and then tighten the Bolts.

DO NOT fully tighten a BOLT in one go and then move on to the next. Rather, In a sequential manner, gradually tighten each Bolt until all Bolts are evenly secured. This methodology will ensure maximum evenness once all Bolts are fully tightened. If the Barstool wobbles adjust the Pre-installed Levellers at the bottom of the Legs until the Barstool is level.

Your Barstool is ready for use.

This Barstool can only be used on a flat, level surface.

Care & Maintenance



- Furniture may scratch floors. We recommend using furniture pads to protect your floors.



- Do not put hot items directly on furniture surface.



- Do not clean furniture with harsh cleansers or polish.



- Do not place furniture under direct sunlight.



- Do not place furniture near heating or cooling vents.



- Do not write on furniture without a padded barrier to protect the surface.



- Do not place furniture outside. For indoor use only.



- Not for commercial use. For residential use only.



- Stains may be removed with mild soap solution and damp cloth.



- Children should not climb or jump on the furniture.

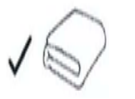

- Dust and pick-up spills using a clean, non-colored, lint-free cloth.