

# ASSEMBLY INSTRUCTIONS

## MODEL : SPINDLE WINDSOR CHAIR

### IMPORTANT

#### PLEASE READ BEFORE YOU CONTINUE FURTHER

THE PRODUCT YOU HAVE PURCHASED WILL GIVE YOU MANY YEARS OF SERVICE IF YOU FOLLOW THE GUIDE LINES FOR IT'S SAFE ASSEMBLY AND PERIODIC MAINTENANCE AND CLEANING.

DO NOT USE ANY TOOLS OTHER THAN THOSE SHOWN.

ANY SPANNERS OR ALLEN KEY REQUIRED ARE INCLUDED WITH THE FITTING KIT.

**DO NOT** FOR ANY REASON USE A POWER TOOL TO ASSEMBLE THIS PRODUCT. IT'S USE WILL INVALIDATE ANY CLAIM YOU MAY HAVE AND COULD MAKE THIS PRODUCT UNSAFE.

DEPENDING ON THE AMOUNT OF USE THIS PRODUCT RECEIVES IT MAY BE NECESSARY TO TIGHTEN UP THE FIXING FROM TIME TO TIME. THIS IS COMPLETELY NORMAL FOR ANY FLAT PACK FURNITURE.

FOR CLEANING YOU MAY USE A DAMP CLOTH (NOT WET) DRY DUSTER AND NORMAL FURNITURE POLISH.

FOR PRODUCT THAT INCLUDE SEAT PADS.

SEAT PADS MAY STAIN OR MARK IF ALLOWED TO COME INTO CONTACT WITH WET OR DAMP OBJECTS AS MATERIALS USED HAVE NOT BEEN SCOTCH GUARDED.

THE SURFACE OF THIS ITEM IS NOT HEAT RESISTANT. ALWAYS USE A PLACEMAT UNDER HOT OR COLD ITEMS TO PREVENT MARKING.





#### Please read instructions carefully

- 1) Remove all wrapping materials, staples and packing straps from the carton.
- 2) Refer to Parts List and Hardware List and ensure they are complete before you start assembling.
- 3) Place all wooden parts on a clean, flat and soft surface (e.g carpet or rug) to prevent parts from being scratched.
- 4) Do not fully tighten bolts and nuts until all parts have been assembled.

#### PARTS LIST (FOR 2 NOS. OF CHAIR)

NO.	COMPONENT	QTY.
P1	CHAIR BACK	2
P2	SIDE LEG FRAME	4
P3	CROSS BAR	2

#### HARDWARE LIST (FOR 2 NOS. OF CHAIR)

NO.	DESCRIPTION	QTY.
H1	M4 ALLEN KEY 	1
H2	M7 X 35 JCBC-W SCREW 	12
H3	M6 x 50 JCBC SCREW 	4
H4	BARREL NUTS 	4
H5	WOOD BUTTON 	4

#### STEP 1

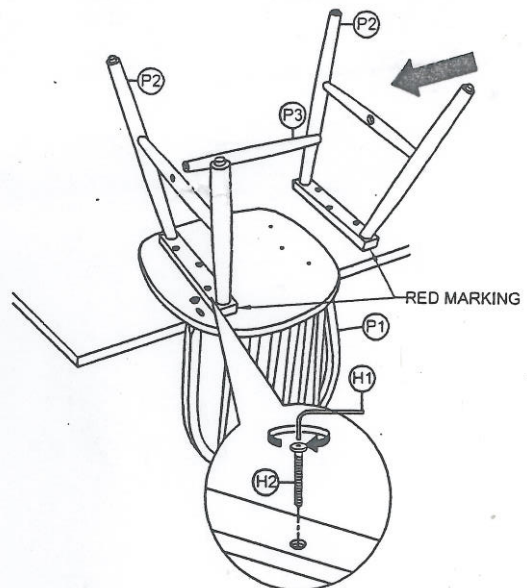

#### STEP 2

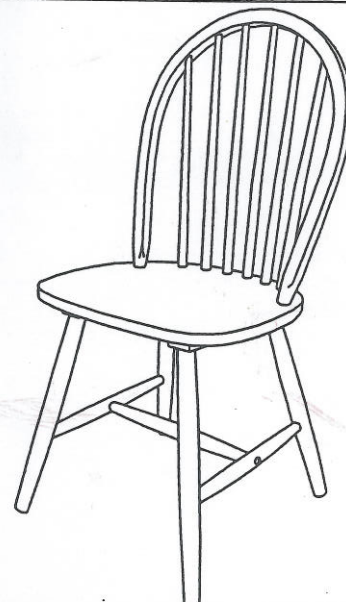
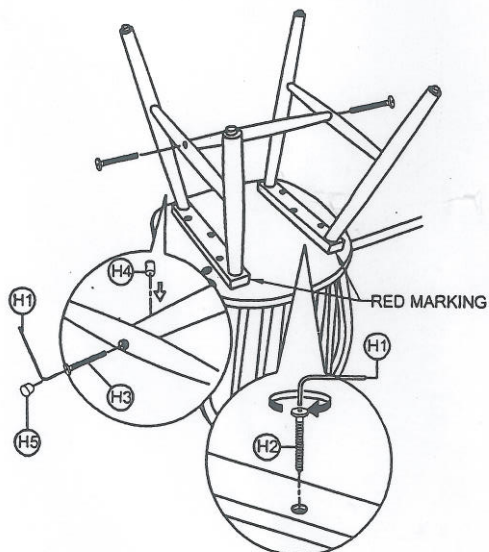

COMPLETE ASSEMBLY

**CAUTION** - To avoid any risk of suffocation to children and animals, dispose off plastic bags immediately.  
- Keep all hardware parts out of reach of children.