

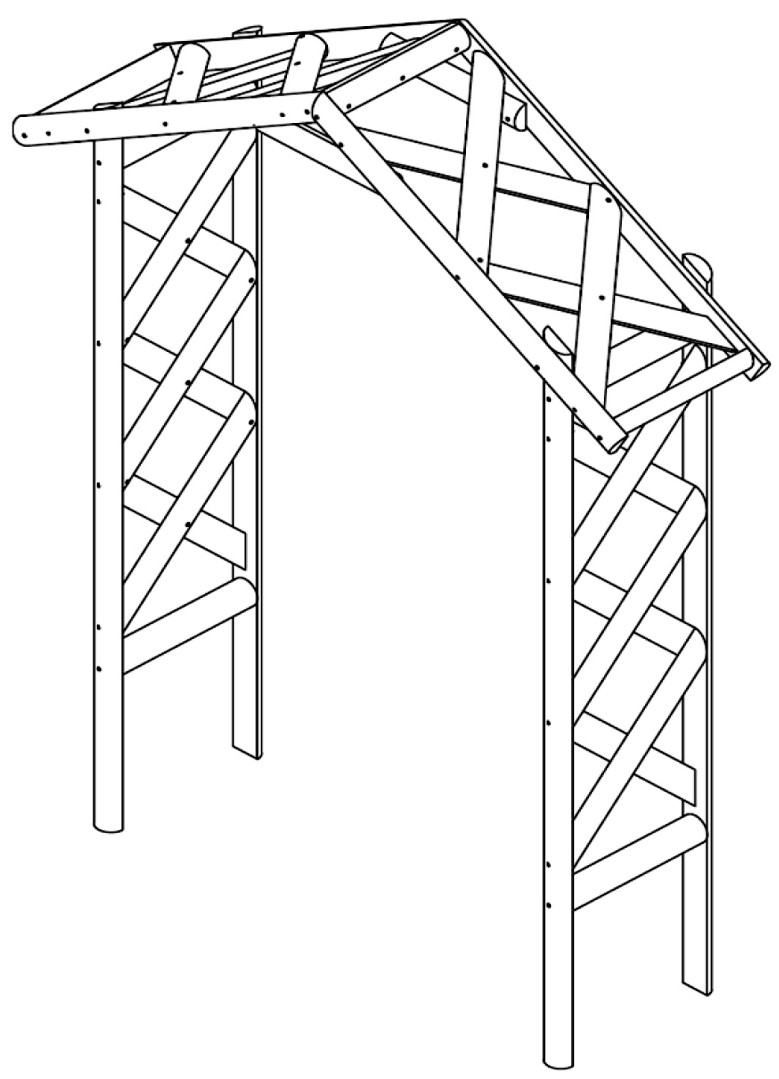





mm
inch

x2

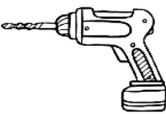

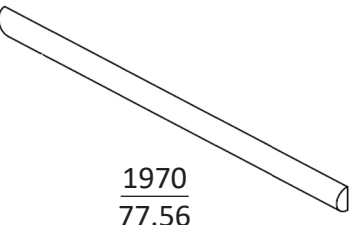
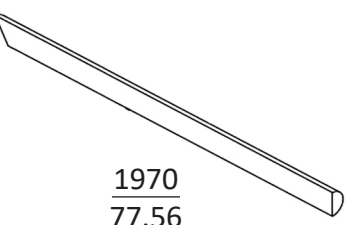
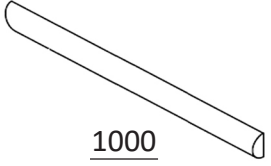
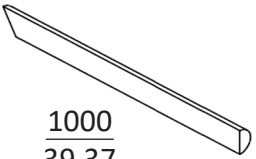
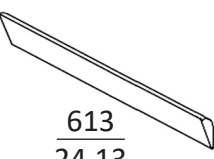
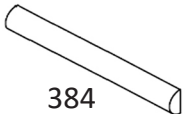
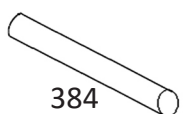
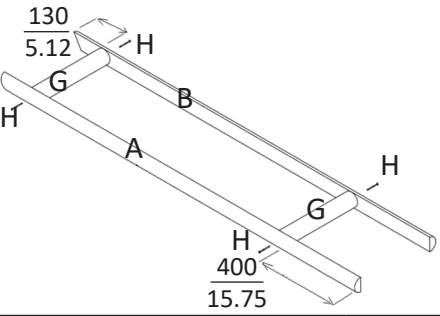
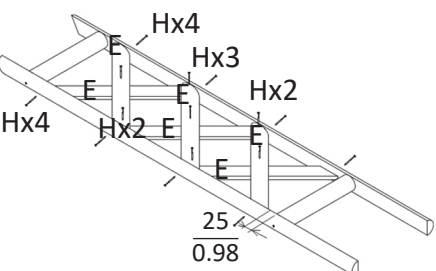
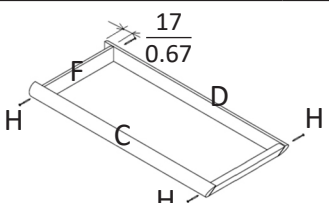
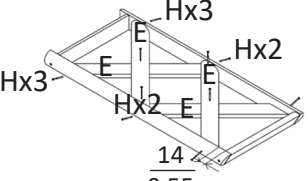
 $\frac{4}{0.16}$				
<p>Ax2</p>  $\frac{1970}{77.56}$	<p>Bx2</p>  $\frac{1970}{77.56}$	<p>Cx2</p>  $\frac{1000}{39.37}$		
<p>Dx2</p>  $\frac{1000}{39.37}$	<p>Ex20</p>  $\frac{613}{24.13}$	<p>Fx6</p>  $\frac{384}{15.12}$	<p>Gx4</p>  $\frac{384}{15.12}$	<p>Hx77</p>  $\frac{4X60}{0.16X2.36}$
<p>1x2</p> 	<p>2</p> 			
<p>3x2</p> 	<p>4</p> 			
<p>5</p> 