

ASSEMBLY INSTRUCTIONS

3' BED

IMPORTANT: READ THESE INSTRUCTIONS CAREFULLY BEFORE ASSEMBLING OR USING YOUR 3' BED FRAME.

PLEASE KEEP THESE INSTRUCTIONS FOR FUTURE REFERENCE.

HEALTH & SAFETY:

DO NOT jump on this bed frame.

DO NOT use this bed frame if any parts are missing, damaged or worn.

DO NOT use this bed frame unless all fixings are secured.

Please keep small parts out of reach of children.

Always use on a level, even surface.

WARNING: If this bed is placed on a non-carpeted floor you must place some protection under all legs to stop the bed frame from moving. If this is not adhered to there is no guarantee if the bed frame collapses.

CARE & MAINTENANCE:

Assemble in the room of use.

Periodically check all screws & fixings to ensure they are secure.





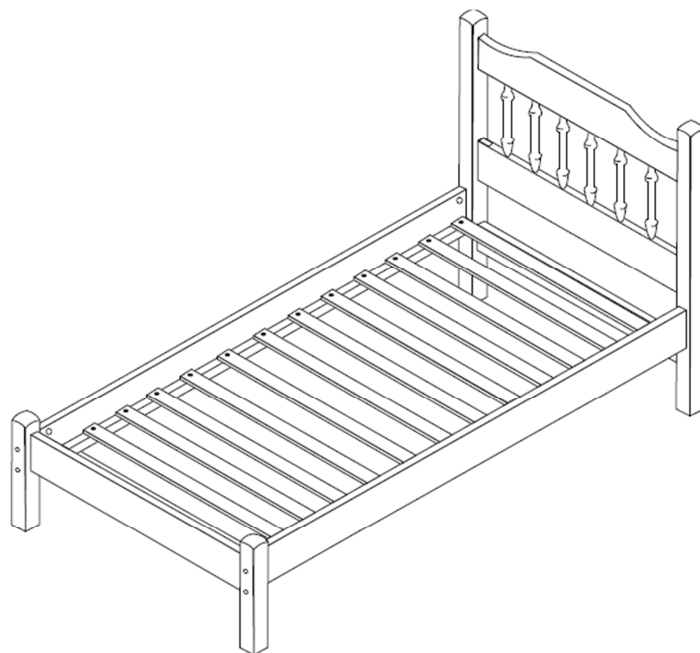

DO NOT push the bed frame as this will damage the legs.

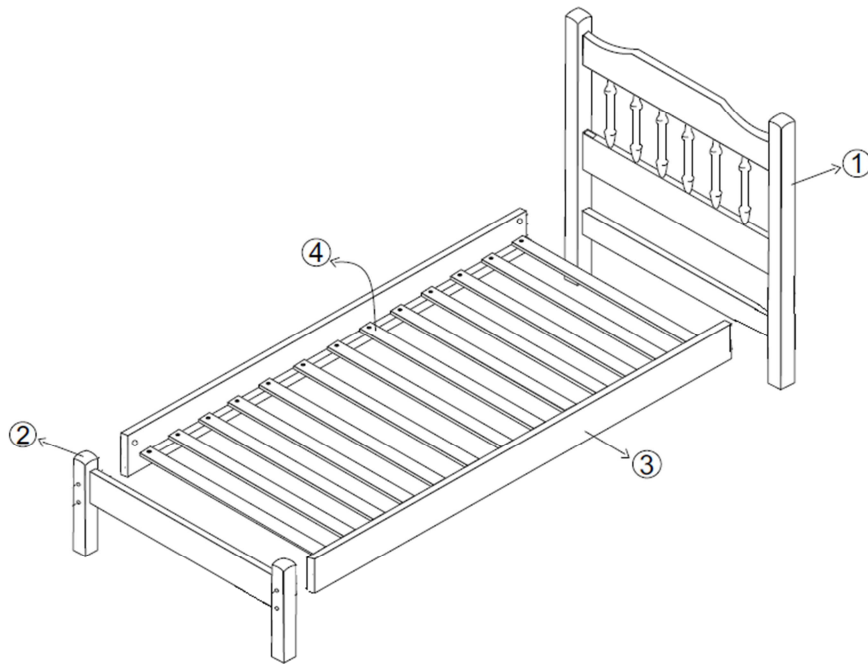
Always lift the bed with two people to reposition.

Keep any sharp objects away from the frame.





Parts List				Hardware List (found in box 1)		
Part	Description	Box	Qty	Part	Description	Qty
1	Headend	1	1	A	¼ " x 110 mm Bolt 	8
2	Footend	1	1	B	Elliptical Nut 	8
3	Side Rail	2	2	C	Allen Key 	1
4	Slat	1	12	D	Wooden Dowel 	4
** You will need a screwdriver and a small mallet (not provided)				E	4 x 35 mm Screw 	24
				F	Spacer Block 	2

Step 1: Attach the side rails (3) to the headend (1) using hardware parts A, B, C and D.
DO NOT use any power tools as this may damage the frame and will invalidate any claim.

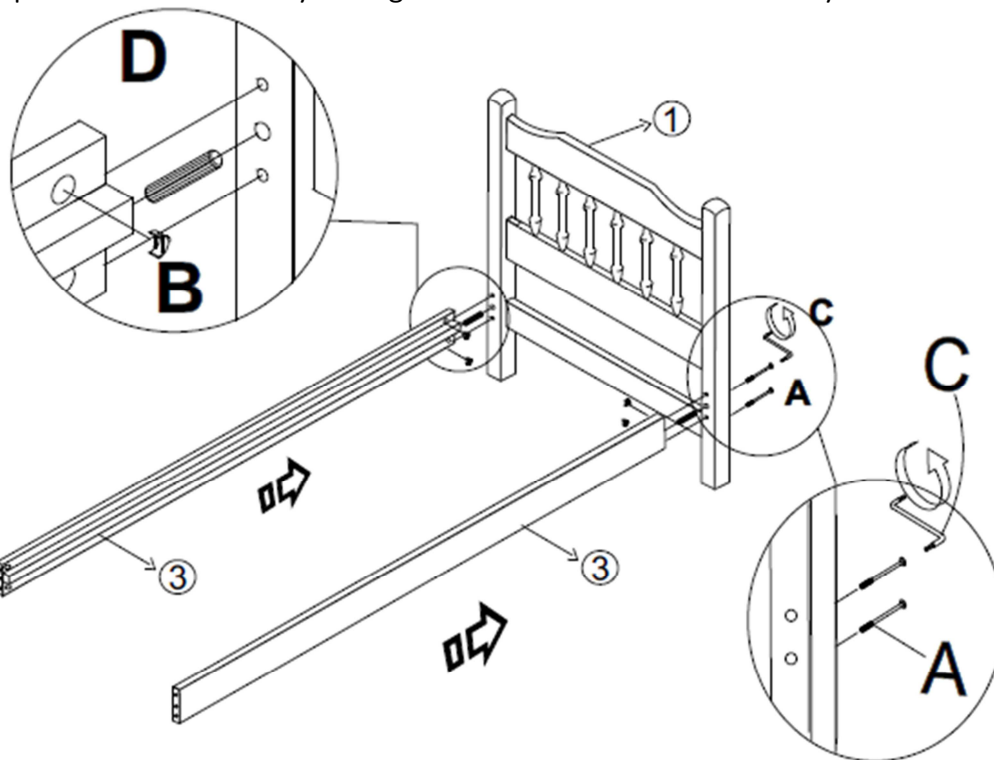

Step 2: Attach the footend (2) using hardware parts A, B, C and D.
DO NOT use any power tools as this may damage the frame and will invalidate any claim.

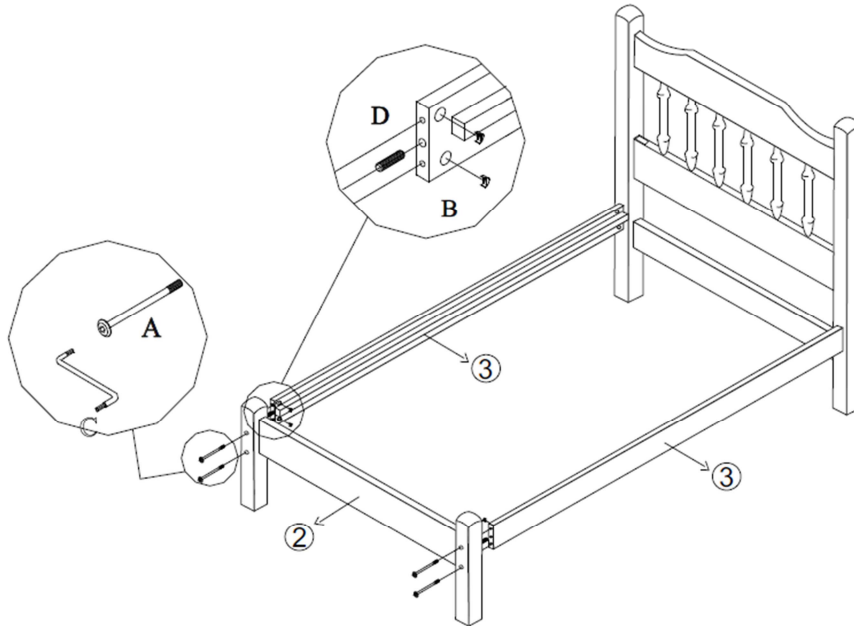

Step 3: Attach the slats (4) to the side rails (3) applying pressure to both sides and using hardware parts E and F with a screwdriver (not provided).
DO NOT use any power tools as this may damage the frame and will invalidate any claim.

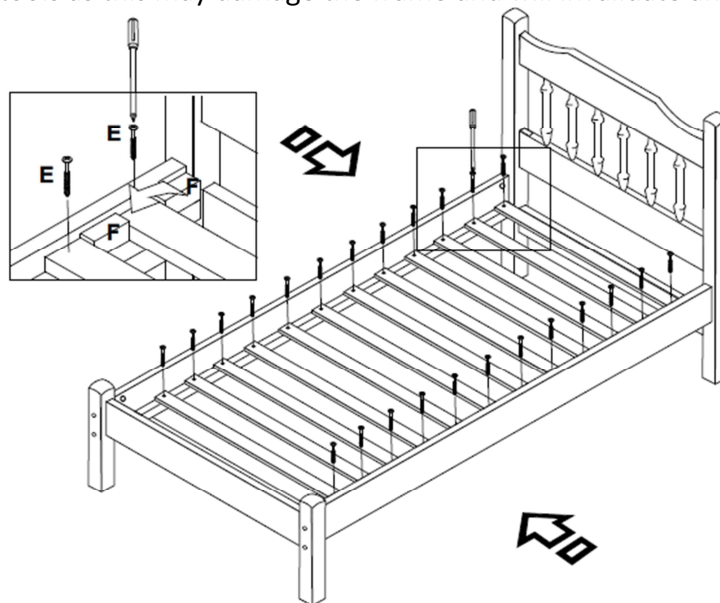

Additional Information: