

ASSEMBLY INSTRUCTIONS



Fine Furniture for every stage of life

Dining Table

ASSEMBLY INSTRUCTIONS

ASSEMBLY TIPS:

1. Remove hardware from box and sort by size.
2. Please check to see that all hardware and parts are present prior to start of assembly.
3. Please follow attached instructions in the same sequence as numbered to assure fast & easy assembly.



WARNING!



1. Don't attempt to repair or modify parts that are broken or defective. Please contact the store immediately.
2. This product is for home use only and not intended for commercial establishments.





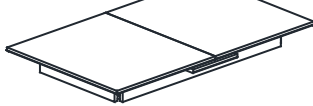

ASSEMBLY TIME

15 MINUTES

PARTS IDENTIFICATION

A	TOP		1PC
B	LEG		4PCS

HARDWARE IDENTIFICATION

1	BOLT (M8 X 95mm - BLK)		8PCS
2	ALLEN WRENCH (M5 x 60mm - BLK)		1PC
3	LOCK WASHER (M8 x 14mm - BLK)		8PCS
4	FLAT WASHER (M8 x 22mm - BLK)		8PCS

ASSEMBLY INSTRUCTIONS

STEP 1

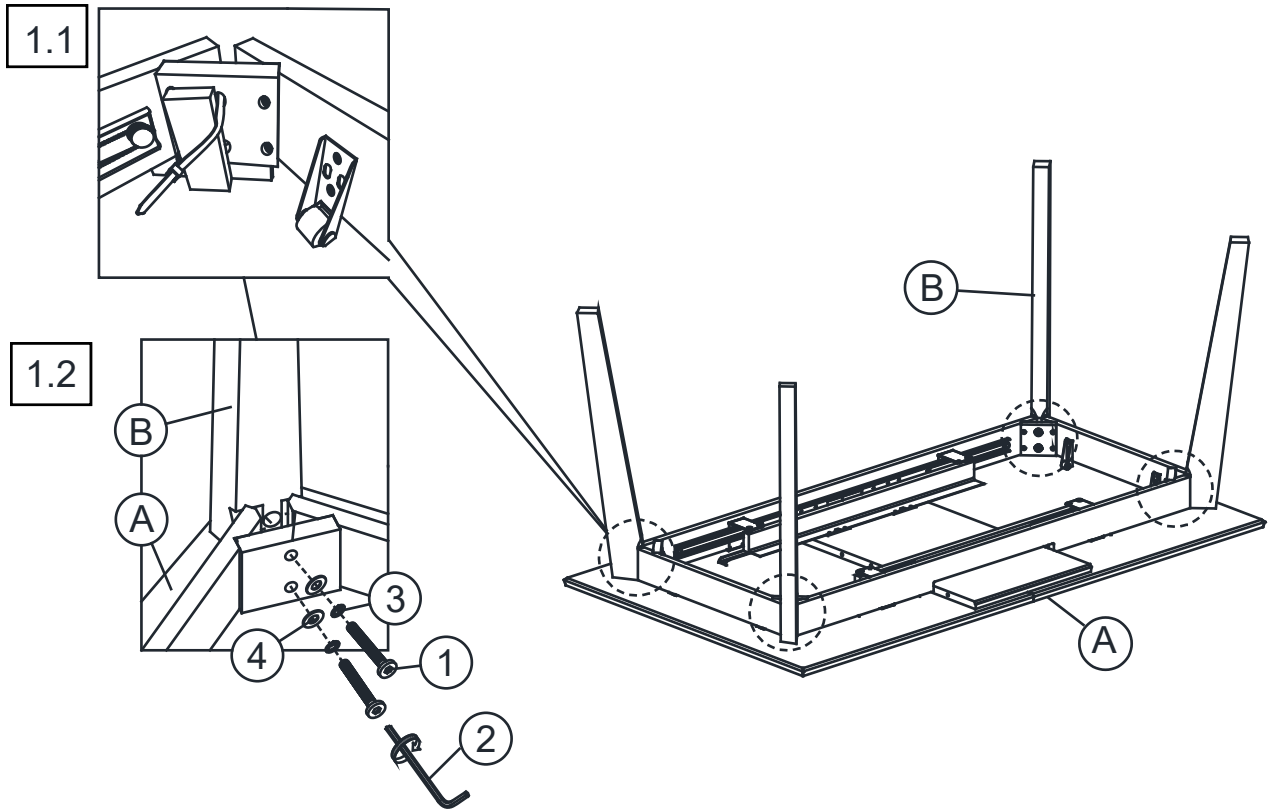

STEP 2

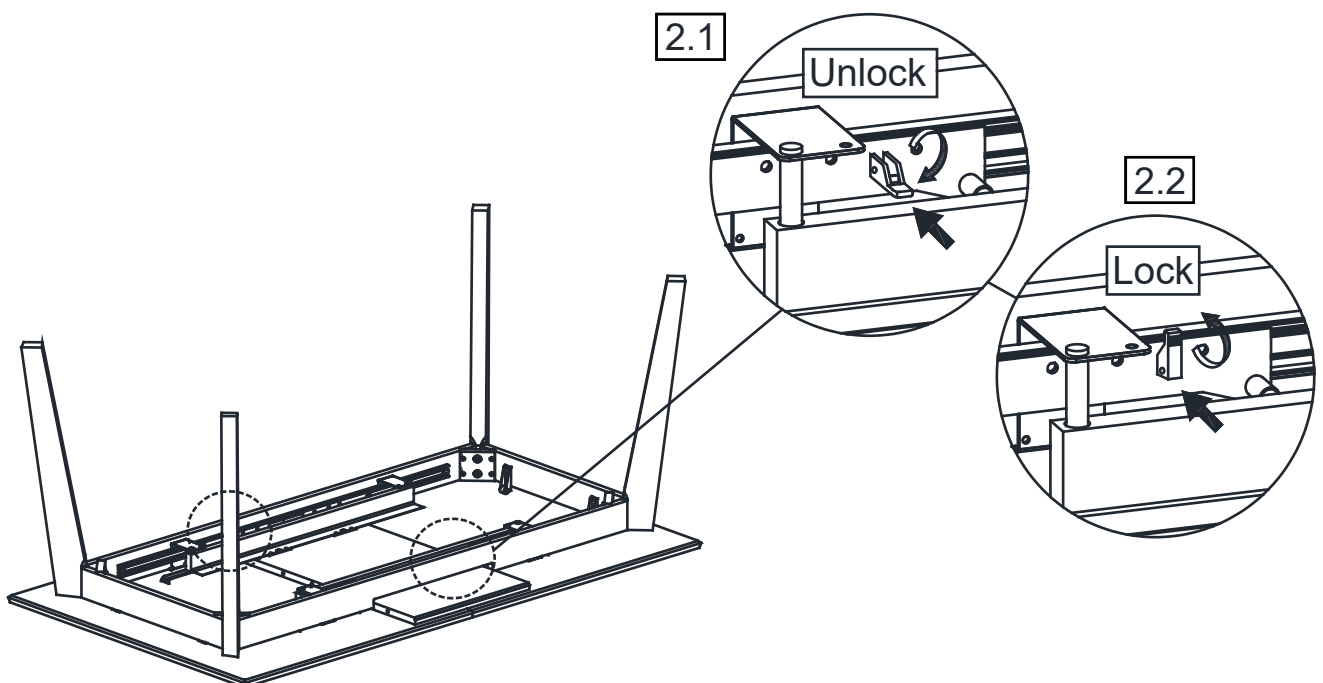

ASSEMBLY INSTRUCTIONS

STEP 3

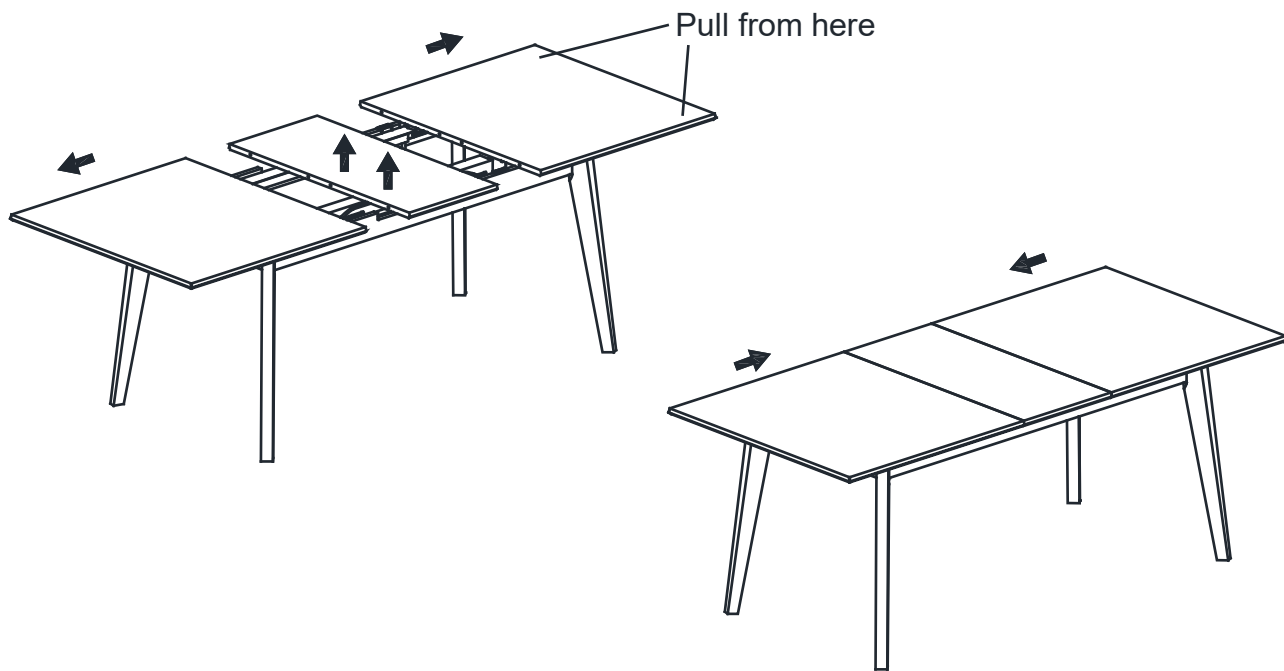

STEP 4

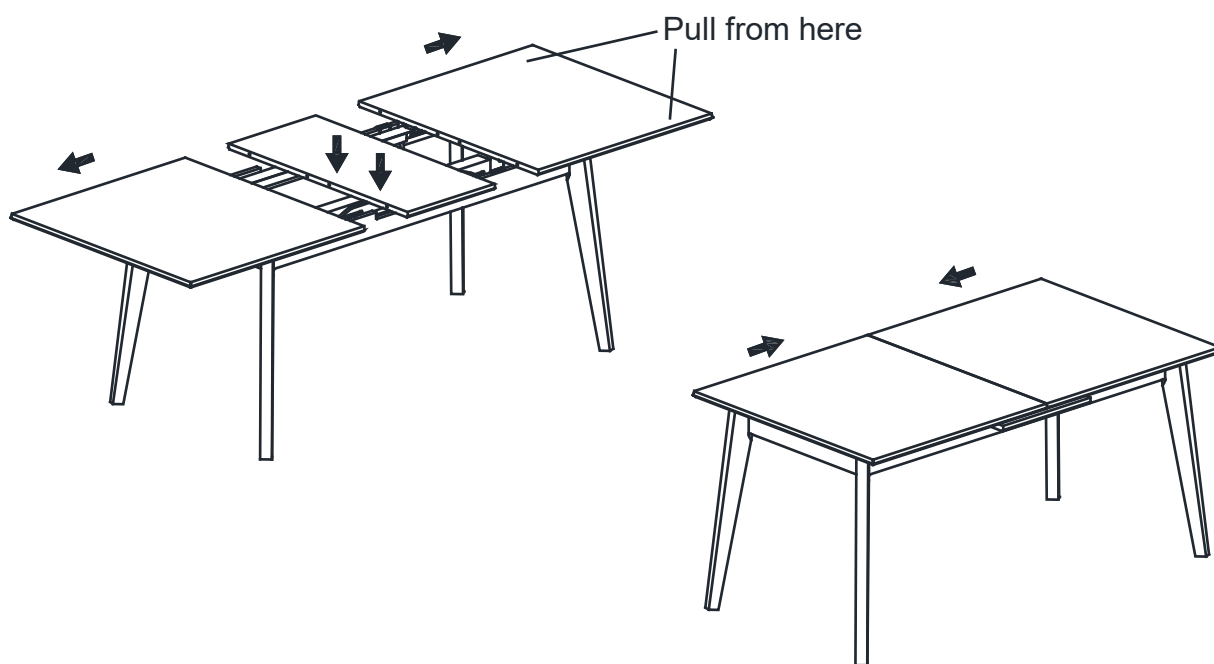

ASSEMBLY INSTRUCTIONS

STEP 5

COMPLETE

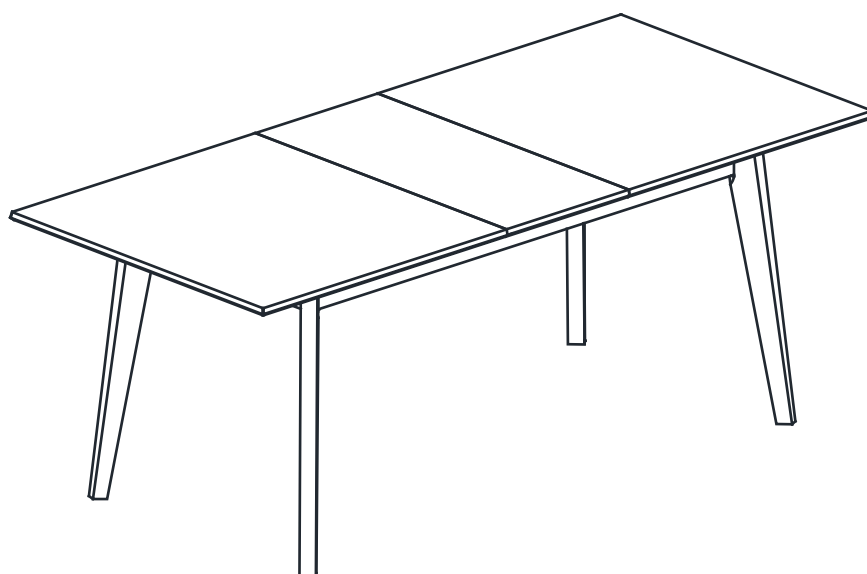

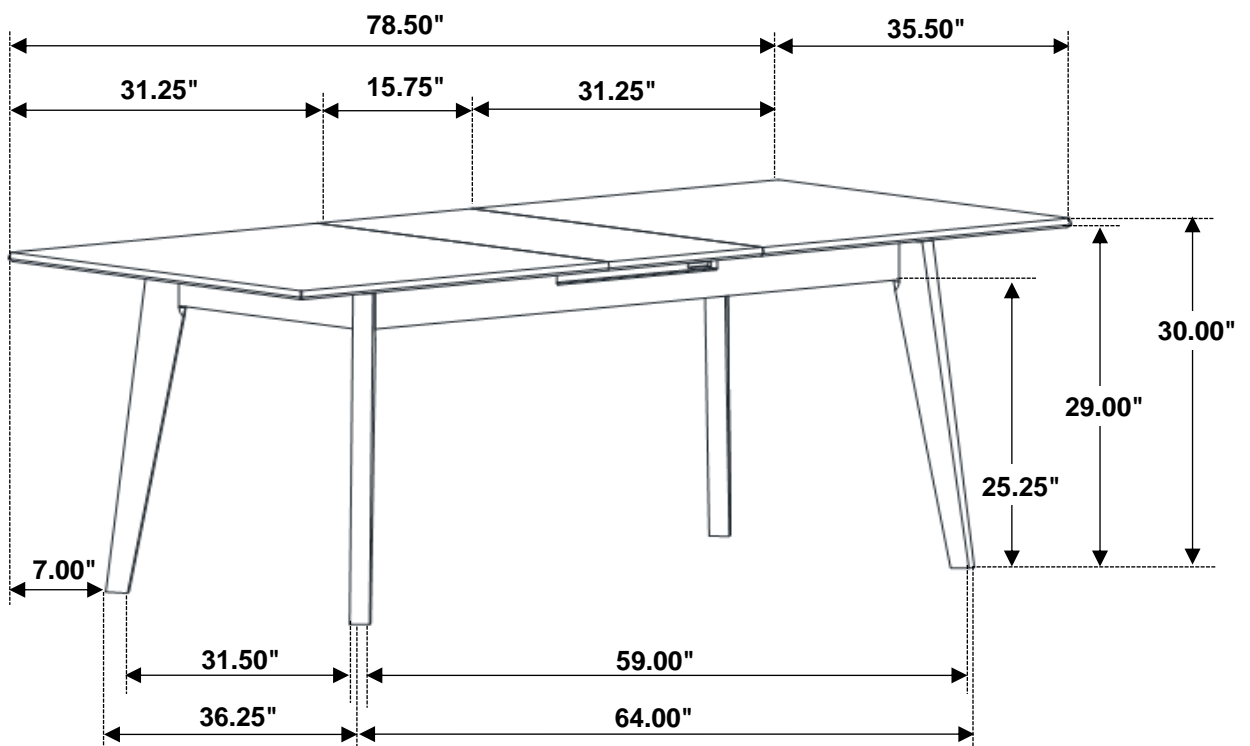

Note : Dimension tolerance $\pm 5\%$

ASSEMBLY INSTRUCTIONS



Fine Furniture for every stage of life

Side Chair

REVISION 0 : 01/03/2024
REVISION 1 : 11/12/2025

ASSEMBLY INSTRUCTIONS

ASSEMBLY TIPS :

1. Remove hardware from box and sort by size.
2. Please check to see that all hardware and parts are present prior to start of assembly.
3. Please follow attached instructions in the same sequence as numbered to assure fast & easy assembly.



WARNING !



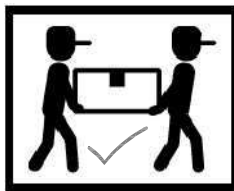



1. Don't attempt to repair or modify parts that are broken or defective. Please contact the store immediately.
2. This product is for home use only and not intended for commercial establishments.

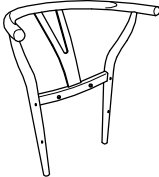

ASSEMBLY TIME

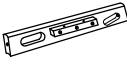
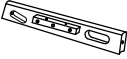
15 MINUTES

PARTS IDENTIFICATION

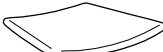
A	BACK FRAME		1PC
B	FRONT LEG FRAME		1PC
C	LEFT SIDE RAIL		1PC
D	RIGHT SIDE RAIL		1PC
E	LEFT STRETCHER		1PC
F	RIGHT STRETCHER		1PC
G	SUPPORT BAR		2PCS
H	SEAT CUSHION		1PC

NOTE :

Quantities shown are for one chair.

Phillips head screw driver is required in the assembly process ; However, manufacturer not provide this item.

ASSEMBLY INSTRUCTIONS

ASSEMBLY TIPS :







1. Remove hardware from box and sort by size.
2. Please check to see that all hardware and parts are present prior to start of assembly.
3. Please follow attached instructions in the same sequence as numbered to assure fast & easy assembly.

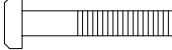

WARNING !

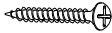
1. Don't attempt to repair or modify parts that are broken or defective. Please contact the store immediately.
2. This product is for home use only and not intended for commercial establishments.

HARDWARE IDENTIFICATION

1	ALLEN WRENCH (M5 x 100MM - BLK)		1PC
2	BOLT (M8 x 50MM - BLK)		4PCS
3	LOCK WASHER (5/16" - BLK)		4PCS
4	LONG PAN HEAD SCREW (#8 x 1 1/2" - BLK)		4PCS
5	SHORT PAN HEAD SCREW (#8 x 1 1/4" - BLK)		4PCS
6	L BRACKET (ZY 447 - BLK)		3PCS
7	FLAT HEAD SCREW (M3.5 x 16MM- RBW)		6PCS

NOTE :

Quantities shown are for one chair.

Phillips head screw driver is required in the assembly process ; However, manufacturer not provide this item.

ASSEMBLY INSTRUCTIONS

STEP 1

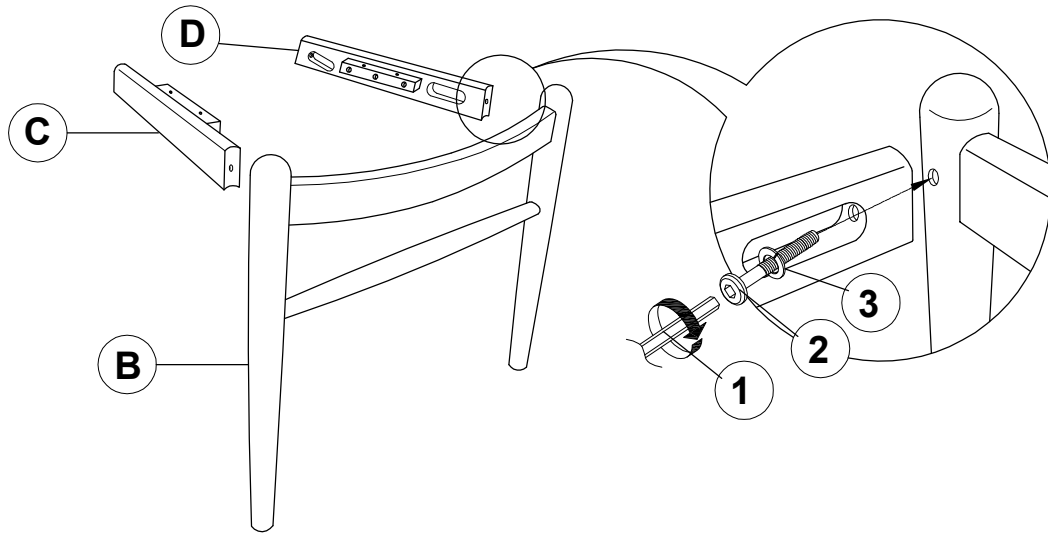

STEP 2

THE HOLE MARK SHOULD BE TOWARDS THE BACK FRAME

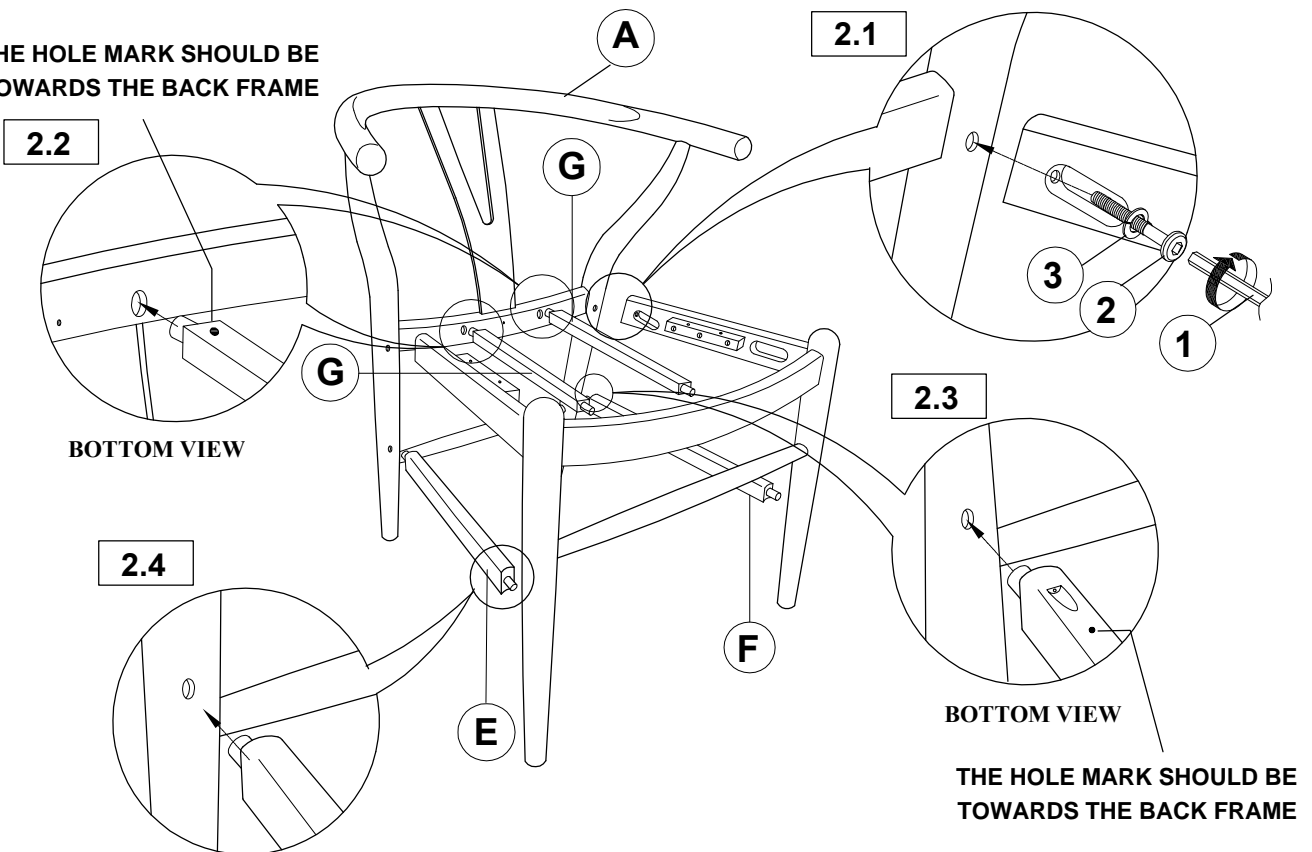

ASSEMBLY INSTRUCTIONS

STEP 3

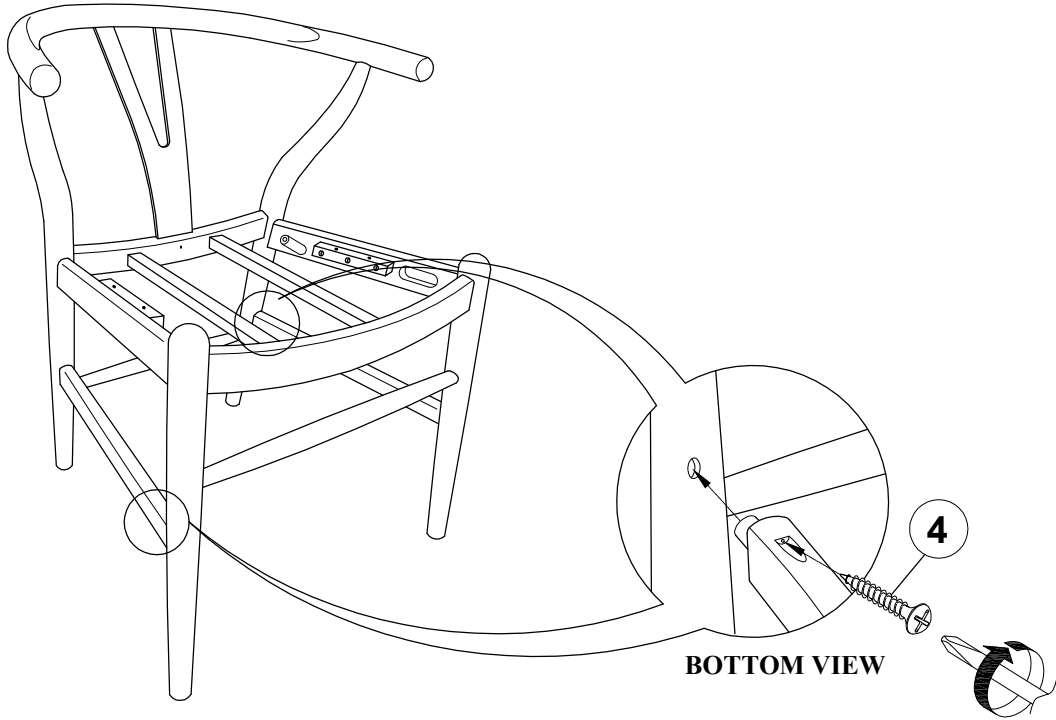

STEP 4

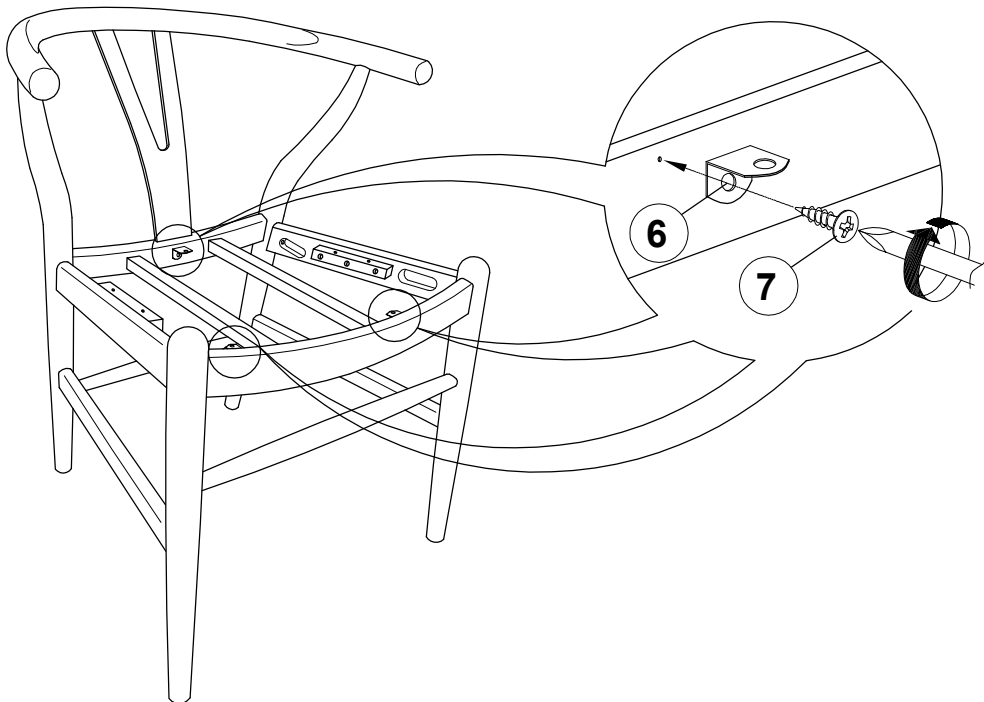

ASSEMBLY INSTRUCTIONS

STEP 5

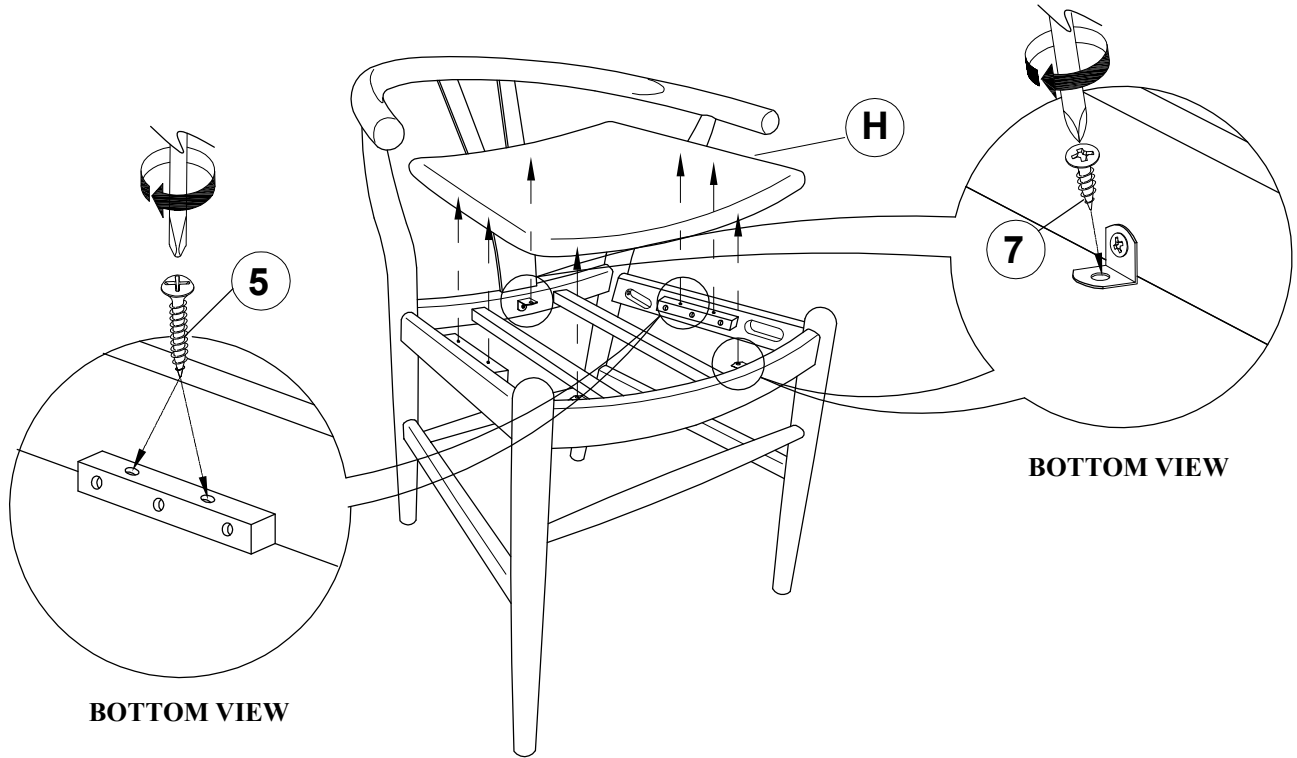

STEP 6 **COMPLETE**

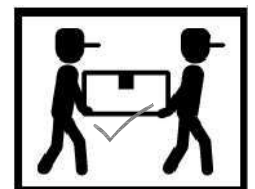
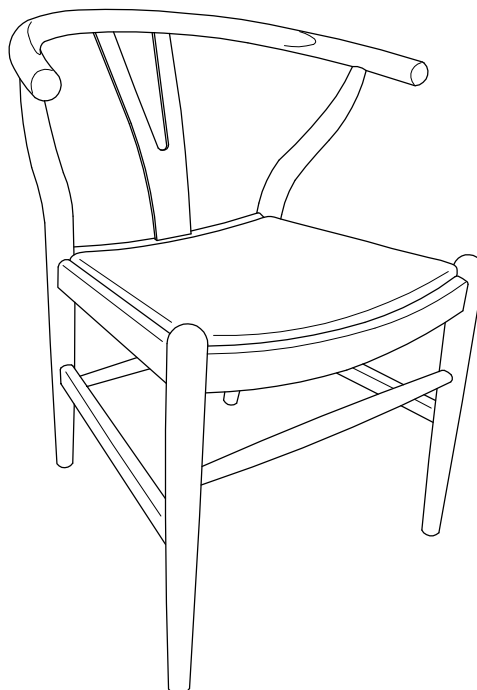

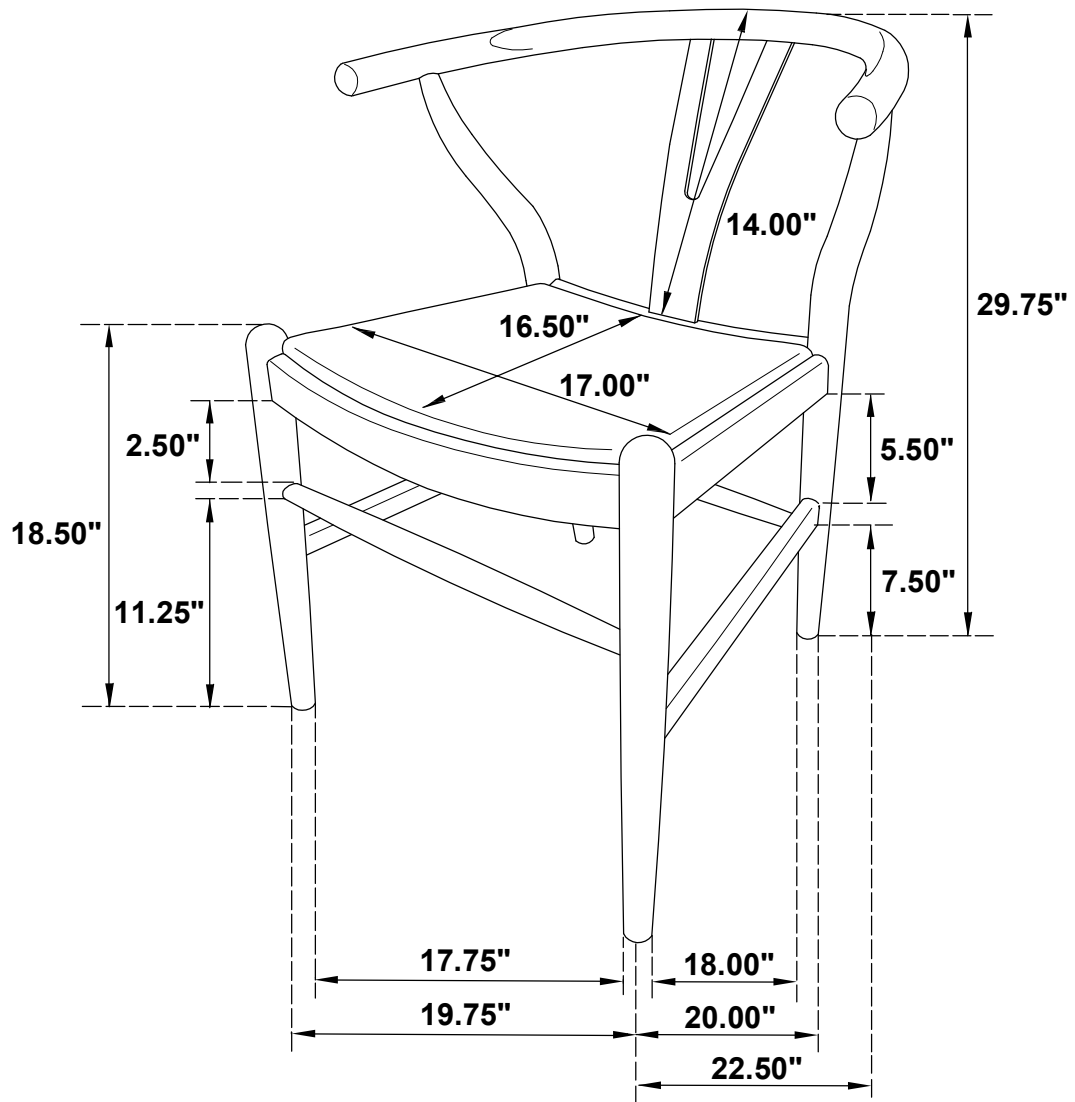

Note: Dimension tolerance $\pm 5\%$