

ASSEMBLY INSTRUCTION

SJ-4

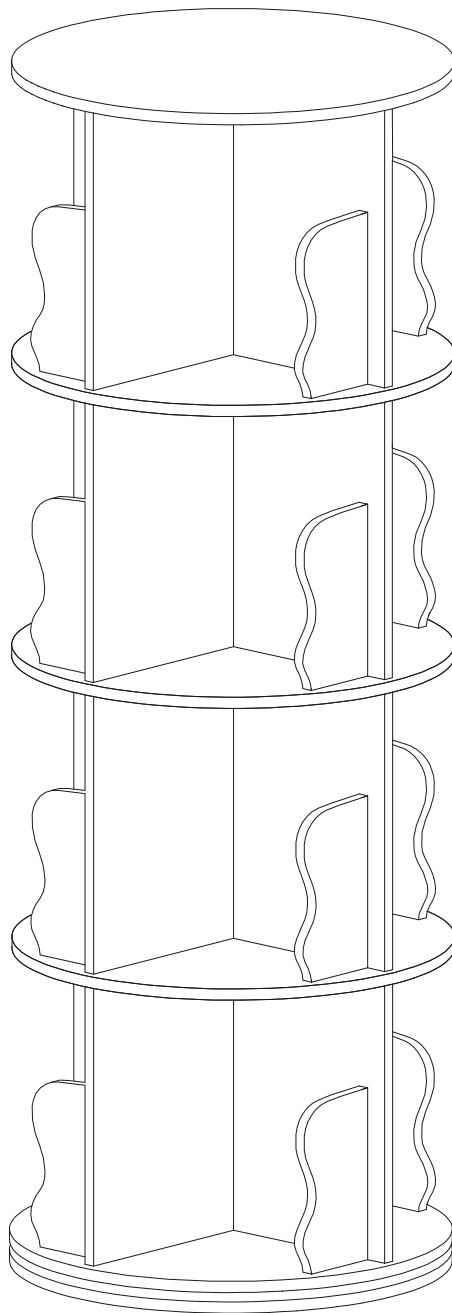

Parts List

1



1pc

2

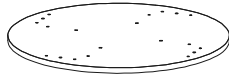

3pcs

3

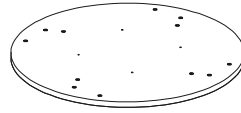

1pc

4

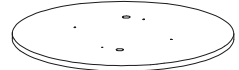

1pc

5

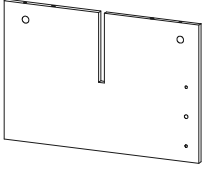

4pcs

6

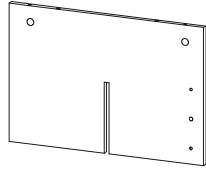

4pcs

7







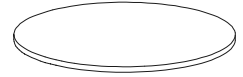

16pcs

8

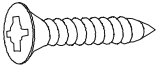

1pc

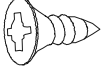
Hardware List

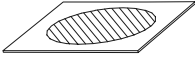
<p>A</p>  <p>$\Phi 6 \times 35\text{mm}$ 48pcs</p>	<p>B</p>  <p>$\Phi 15 \times 9\text{mm}$ 48pcs</p>	<p>C</p>  <p>M4*30mm 48pcs</p>
<p>D</p>  <p>$\Phi 6 \times 30\text{mm}$ 64pcs</p>	<p>E</p>  <p>1pc</p>	<p>F</p>  <p>M4*12mm 8pcs</p>
<p>G</p>  <p>4pcs</p>	<p>H</p>  <p>48pcs</p>	

STEP 1:

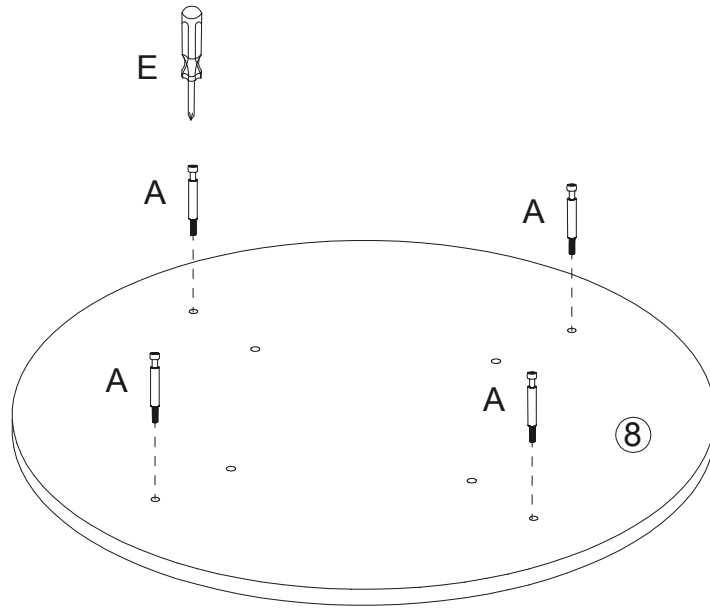
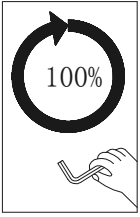

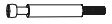

A

Φ6*35mm
4PCS

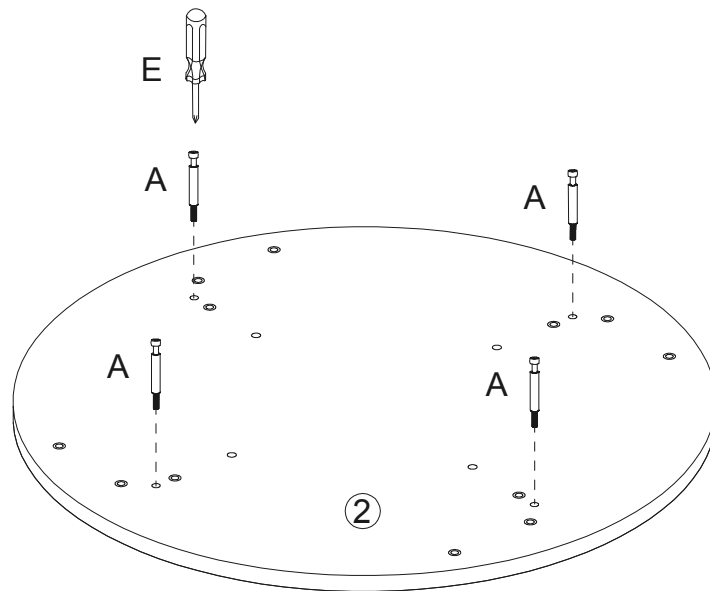
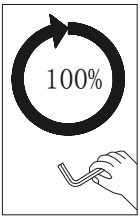
E

1PC

STEP 2:



A

Φ6*35mm
12PCS

E

1PC

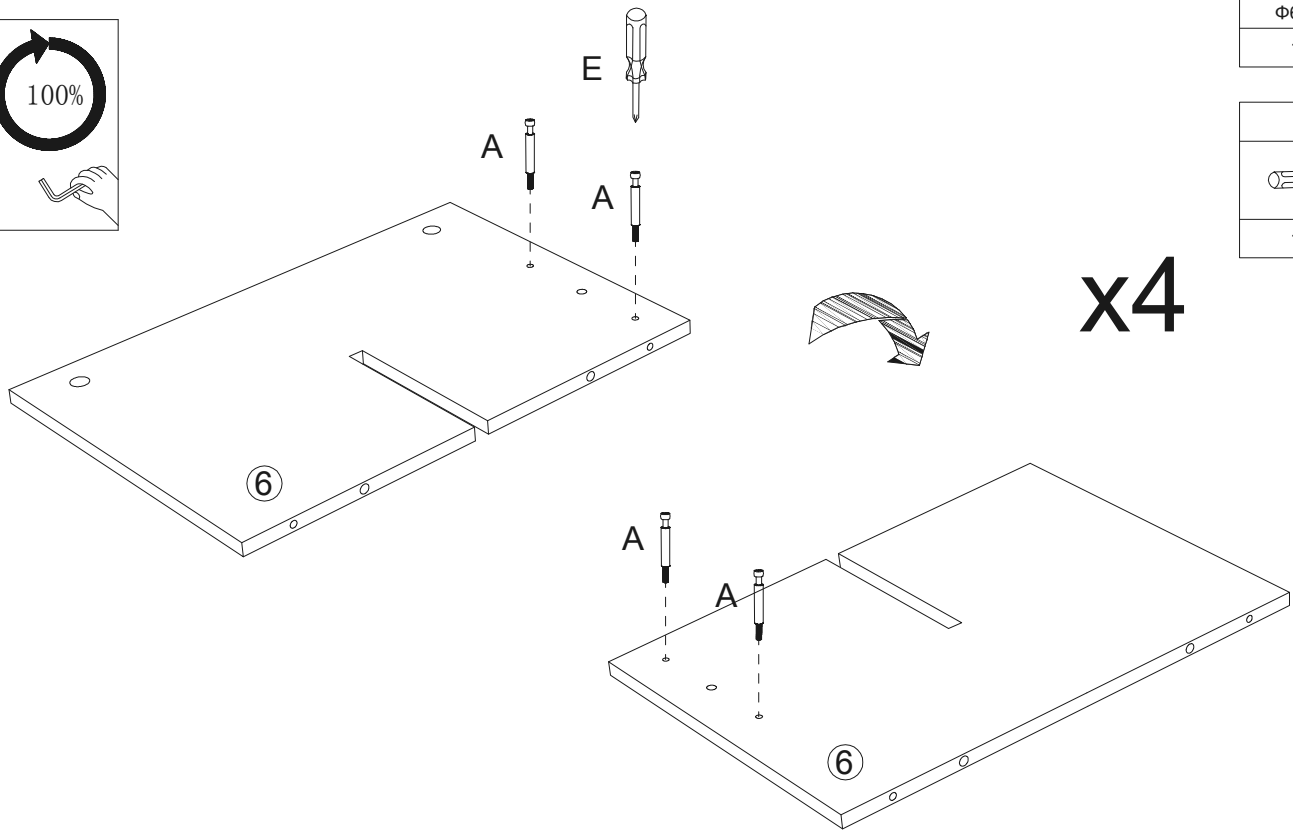
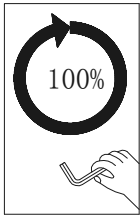
x3

STEP 3:



A



Φ6*35mm

16PCS

E



1PC

STEP 4:

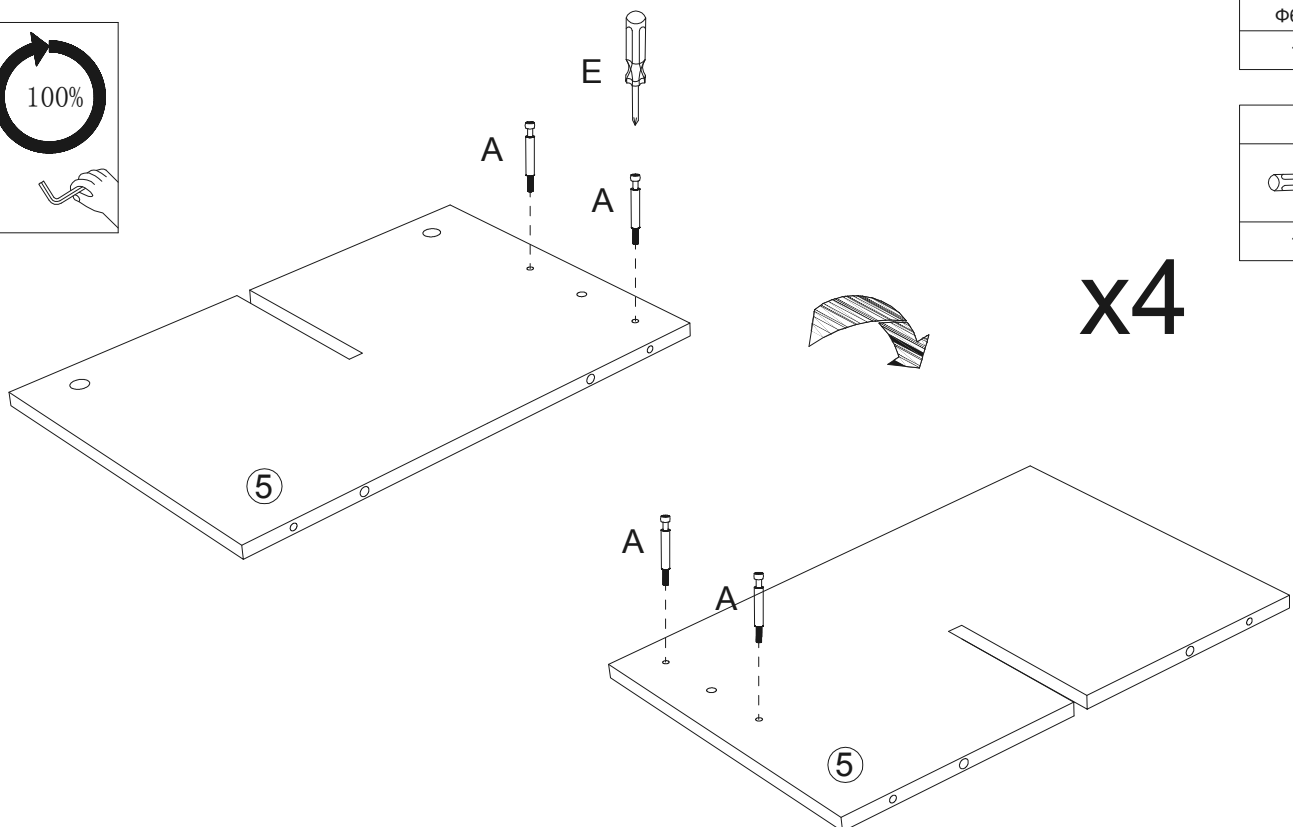
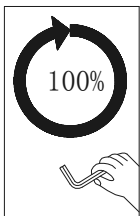

A

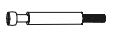

Φ6*35mm

16PCS

E



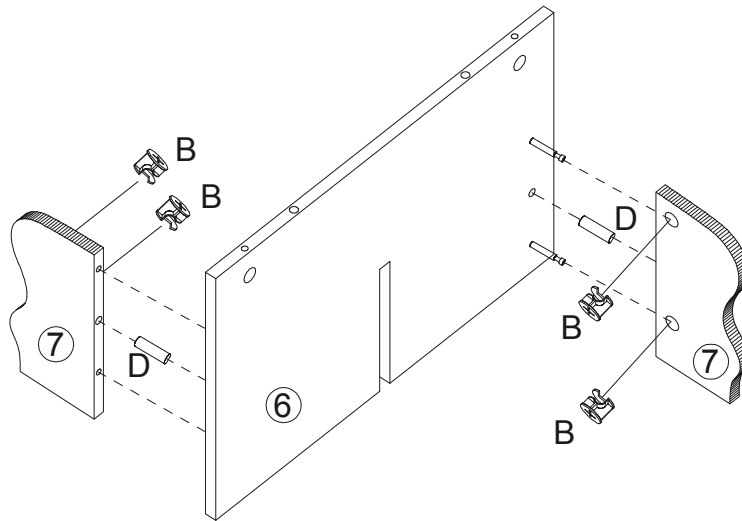
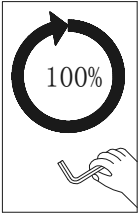

1PC

STEP 5:

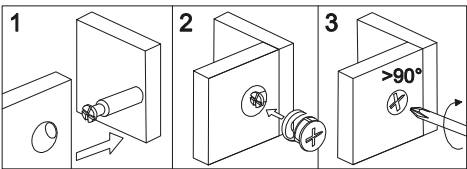

x4



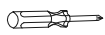

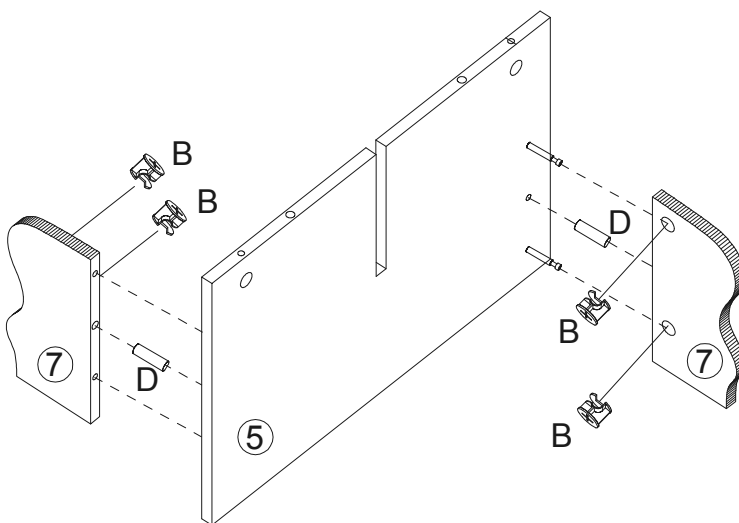
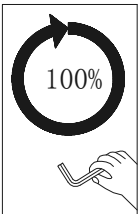

B
 Φ15*9mm
16PCS
D
 Φ6*30mm
8PCS
E

1PC

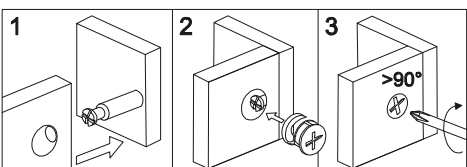
STEP 6:



x4



B
 Φ15*9mm
16PCS
D
 Φ6*30mm
8PCS
E

1PC

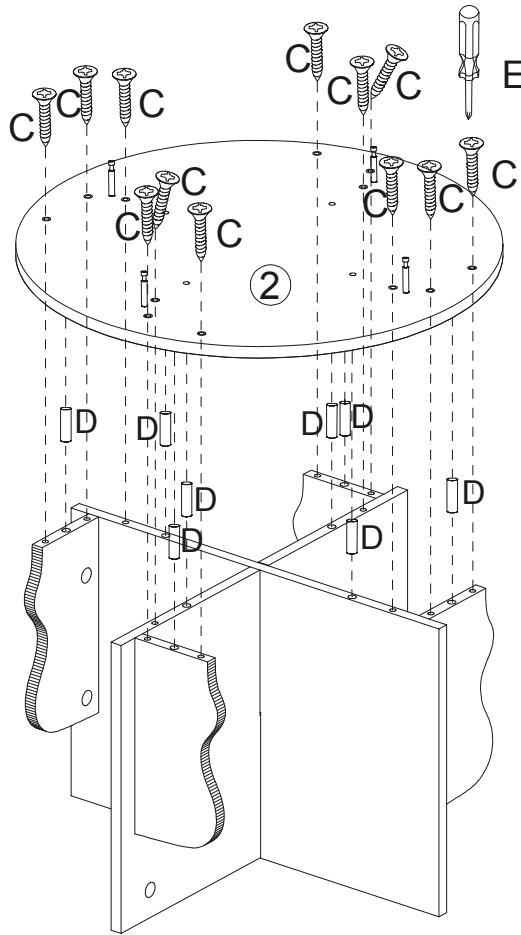
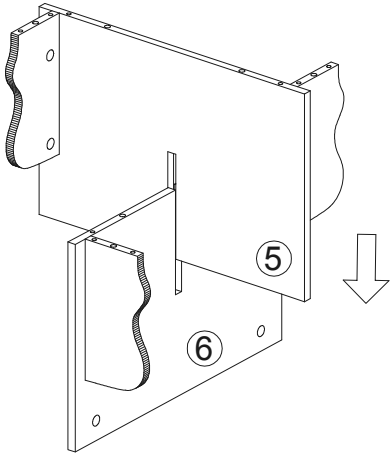
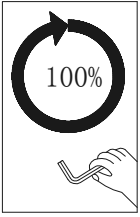
STEP 7:



C
M4*30mm
36PCS

D
Φ6*30mm
24PCS

E
1PC

x3

STEP 8:

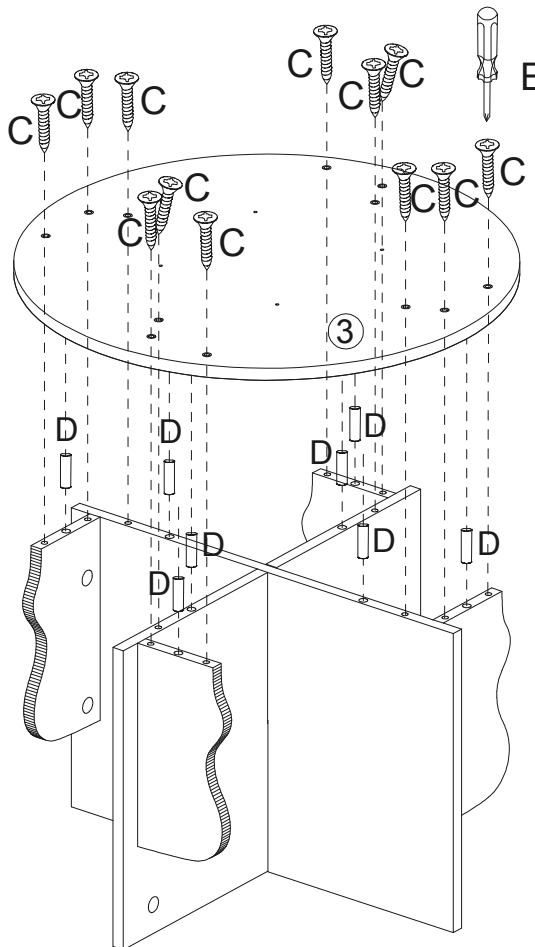
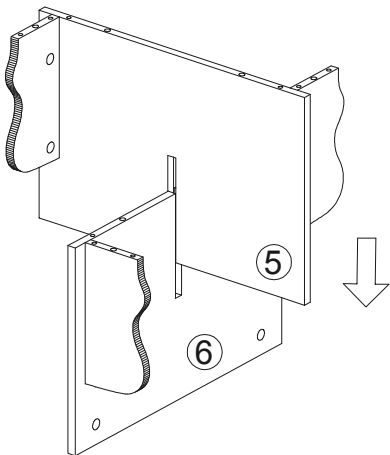
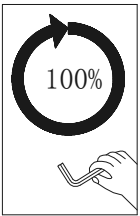



C
M4*30mm
12PCS

D
Φ6*30mm
8PCS

E
1PC

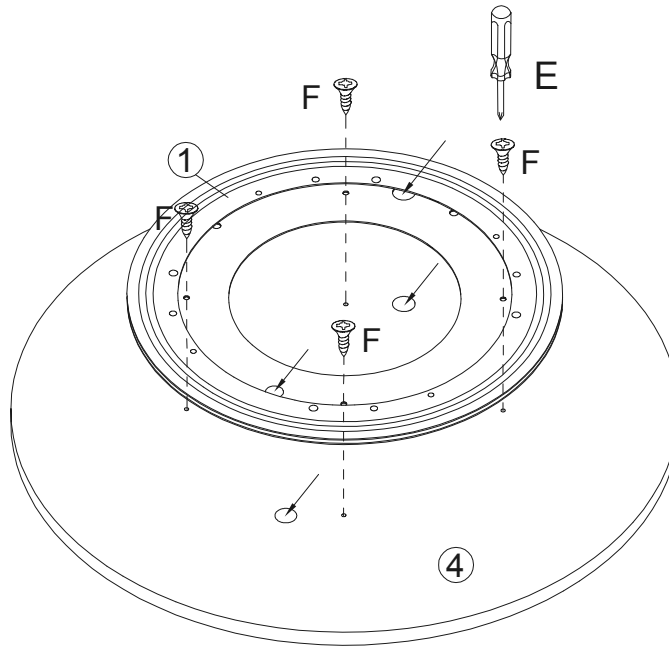
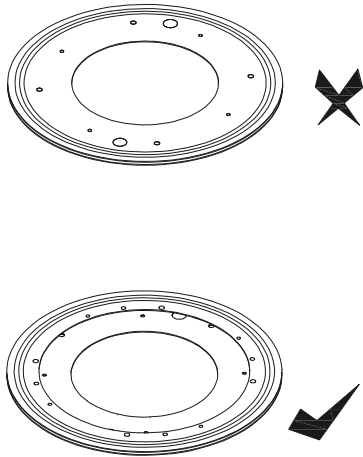
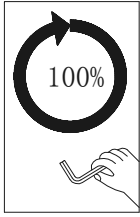
STEP 9:



F

M4*12mm
4PCS
E

1PC

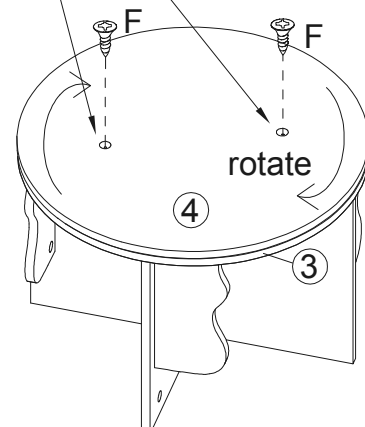
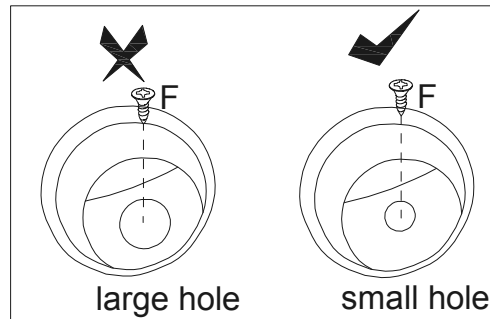
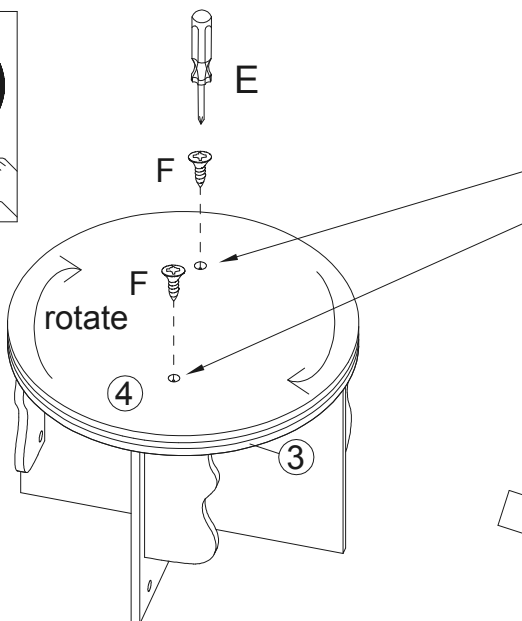
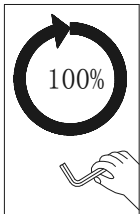
The big holes dial 1 and Board 4 should be aligned, and After allscrews are installed,lock them100%

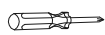
STEP 10:





F

M4*12mm
4PCS
E

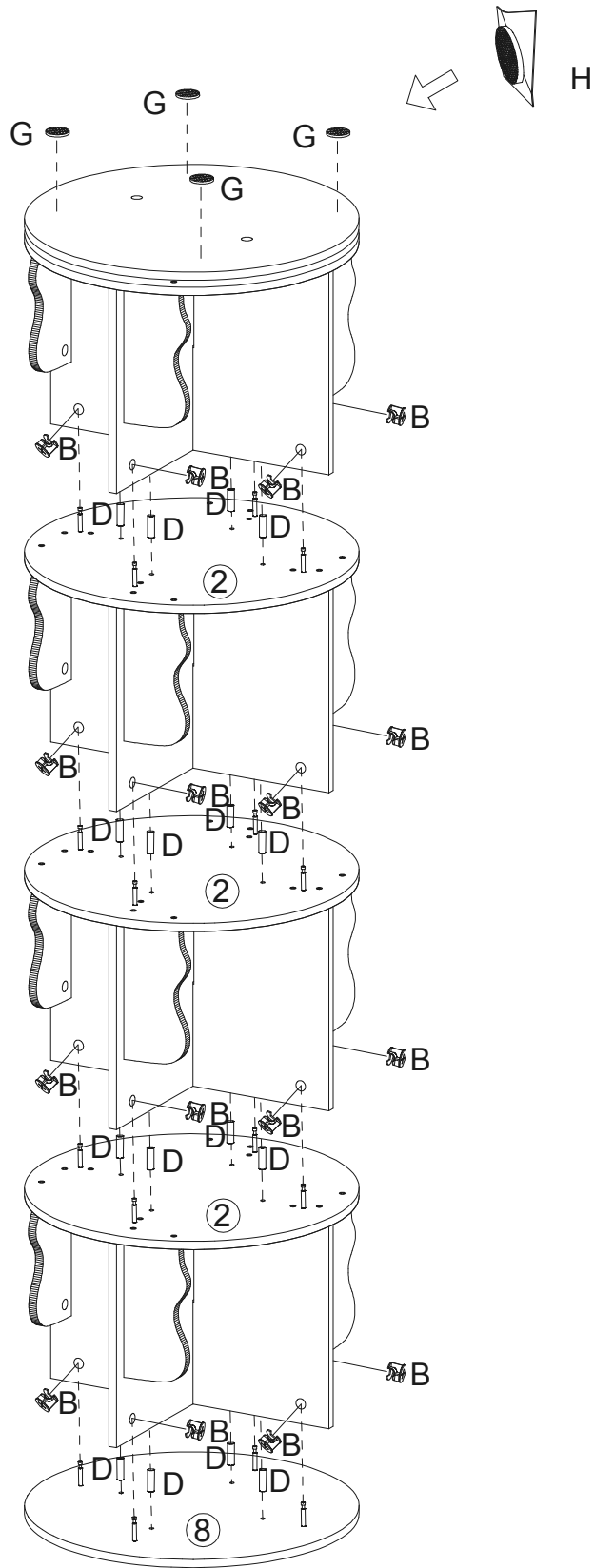
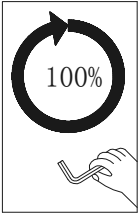
1PC

Board 4 can be rotated to any position until it is aligned with the hole of dial 1 and the screw hole of Board 3

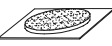
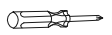
STEP 11:

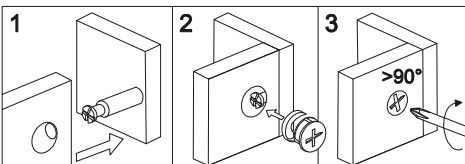

B
 Φ15*9mm 16PCS
D
 Φ6*30mm 16PCS
G
 4PCS
E
 1PC



STEP 12:

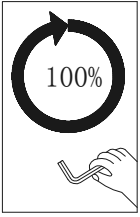

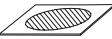
H

48PCS

