

# Metal Garden Shed

## OWNER'S MANUAL

### Instructions for Assembly

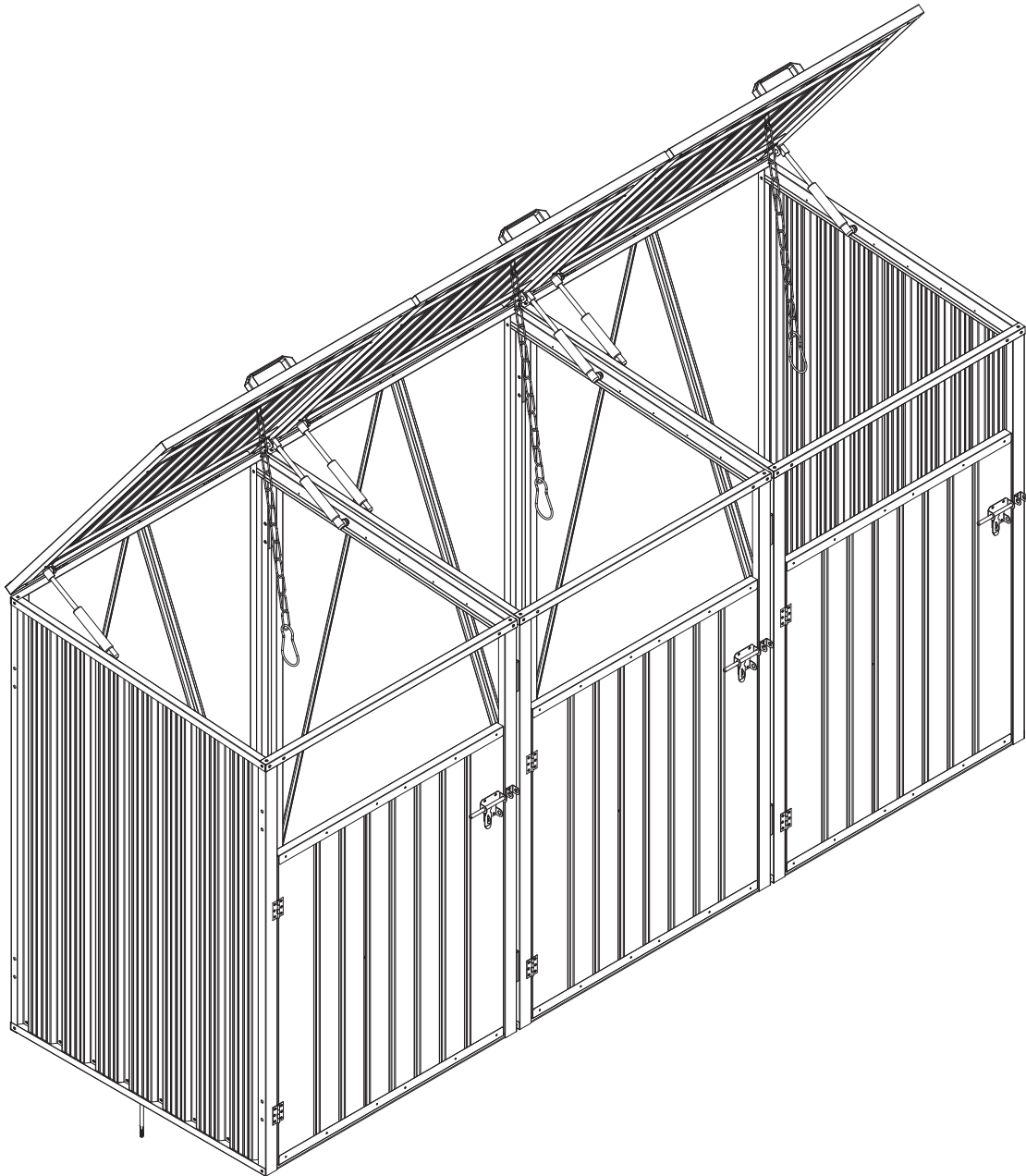

## HFTP-157

Requires two people and takes 1-1.5 hours for Installation.  
Quick & Easy Assembly

# BEFORE YOU START

---

## Owner's Manual

Prior to installation, it is important that you contact your local government authority to determine if building approval is required. Study and understand this owner's manual. Important information and helpful tips will make your construction easier and more enjoyable.

## Assembly instructions

Instructions are supplied in this manual and contain all appropriate information for your building model. Review all instructions before you begin. During assembly, follow the step sequence carefully for correct results. Please be aware: **this unit takes two people about one full day to complete.**

## Parts

Check to be sure that you have all the necessary parts for the building.

Separate contents of the carton by the part number while reviewing parts list.

Familiarize yourself with the hardware and fasteners for easier use during construction. These are packaged within the carton. Note that extra fasteners have been supplied for your convenience.

---

## TOOLS MAY REQUIRED

---

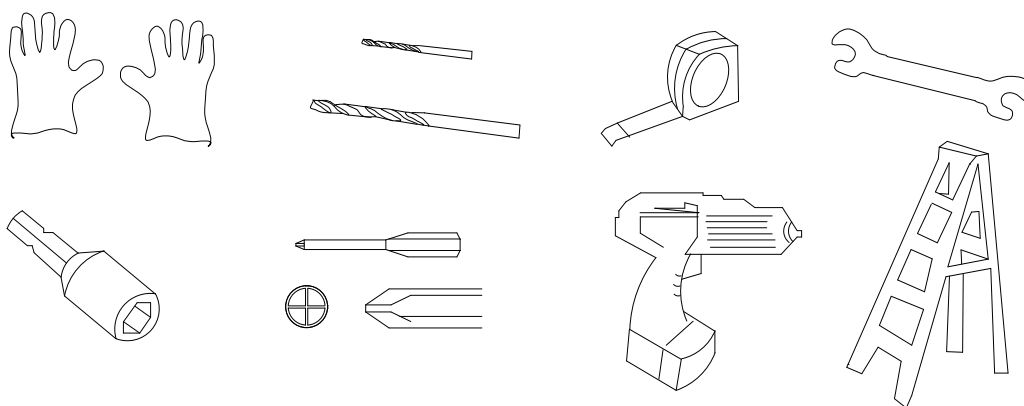

**Use heavy duty gloves when handling steel sheets and flashing**

---

## PLAN AHEAD

---

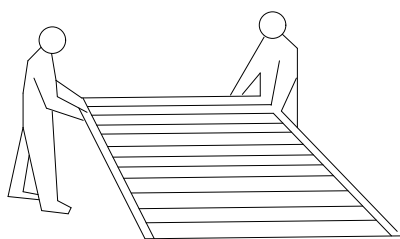

**It requires two people a full day to complete installation**

### Watch the weather:

Please be sure the day you select for installation is dry and calm.

**DO NOT attempt to assemble your shed in windy weather** because of risk of damage to panels, or personal injury. Be careful of wet or muddy ground.

### Teamwork:

Whenever possible, two or more people should work together to assemble the building. One person can position parts or panels while the other is able to handle the fasteners and the tools.

# PLAN AHEAD

---

## Site Selection

- Avoid overhanging trees as much as possible as leaves will make regular cleaning necessary and broken branches are a potential hazard.
- Small trees, bushes or fences nearby can be helpful, acting as a wind break.

## Site Preparation

The site must be prepared so that the base of the shed is level all round and checking with a spirit level is required.

The base can be constructed by treated timber or concrete, in order to stop the moisture getting into the shed. **The shed is not designed to be built onto lawn directly.** Also the ground will get muddy during rainy days.

If a concrete pad is made, it is important that this slopes towards the edges to prevent water ingress.

Time must be allowed for any concrete or cement to dry before building the shed on top.

Bases can also be constructed from bricks, blocks, or mounted on a concrete pad.

The bricks or blocks should be cemented onto firm and level concrete footings and the greenhouse frame drilled and screwed to the base.

---









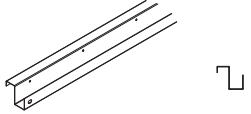
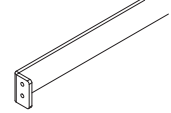
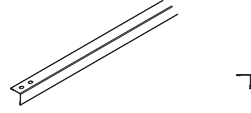
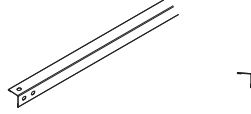
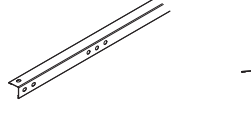
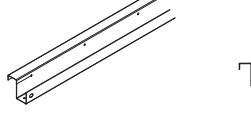
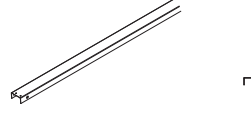
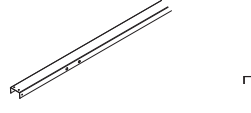
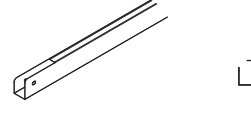
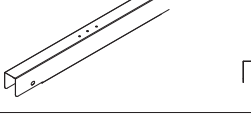
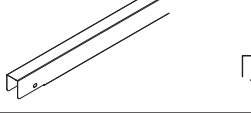
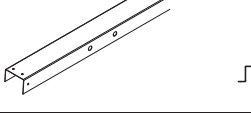
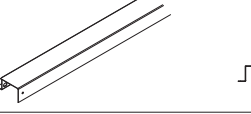
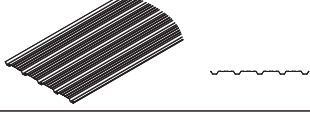
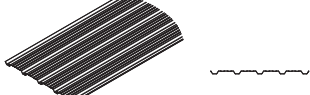

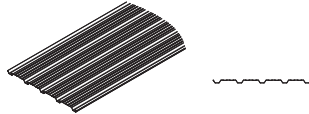
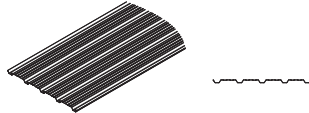
## IMPORTANT NOTES:

---

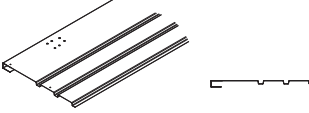
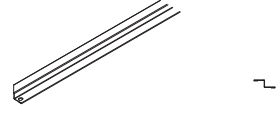
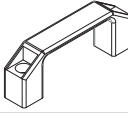

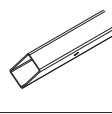
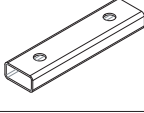

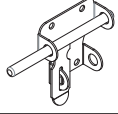
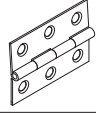

- Find someone to help you: it is much easier with someone to hold parts, pass tools ect. Also some steps require two people to lift structures together. This is not very heavy work so would suit most able-bodied people.
- Allow plenty of time: rushing often causes errors and the re-doing of incorrect assemblies. If you have never built a shed before, it can take most of a day to carefully complete the construction.
- Have the right tools to hand.
- Safety clothing as recommended in the 'Tools' section.
- Ideally lay out the parts and check that all are present before commencing construction. Lay on cloths or plastic sheets if there is any risk of scratching the parts.
- Tighten all nuts carefully, being sure not to miss any. Check the frame is square and using a spirit level to check that it is upright.

# PARTS LIST

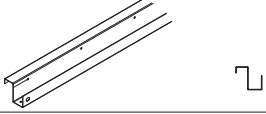
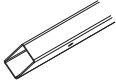
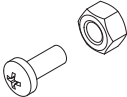
NO.	PART	Qty.
1		6
3		3
4		3
7		3
8		3
9		3
15L		3
15R		3
20		6
20D		3
20U		3
25L		3
25R		3
P1AL		1
P1AR		1

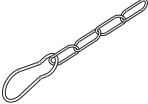
NO.	PART	Qty.
P4AL		1
P4AR		1
P5		3
P6		3
DL1		3
DR1		3
B1		6
C6		3
DX1		6
10		3
GS		8
DF		3
DG		3
DH		12
F1		314

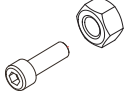
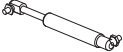
# PARTS LIST

NO.	PART	Qty.
11		3
12		3
F2	 M4X10	42
S2		236
		3
F6		9
F4		6
G3		6
M8		6
F3		12

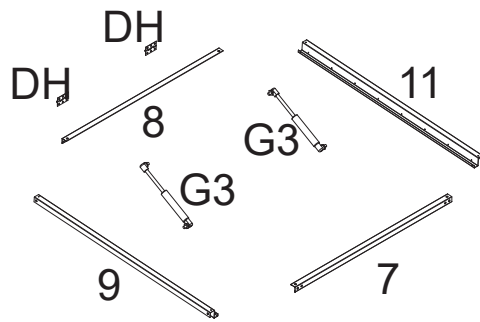
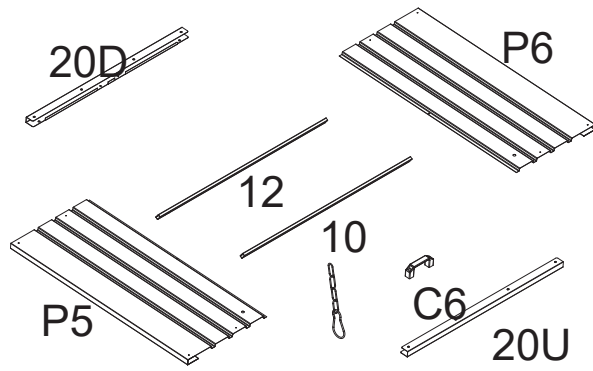

15R



25R



DF

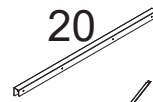
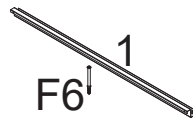
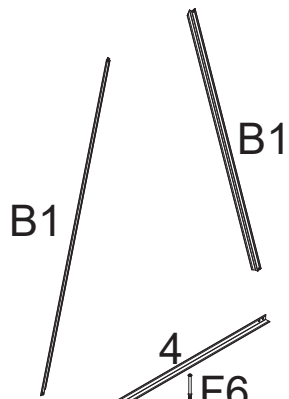

DG

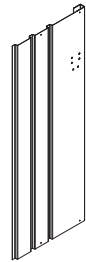

DR1



DX1



20

DH

DL1

DH

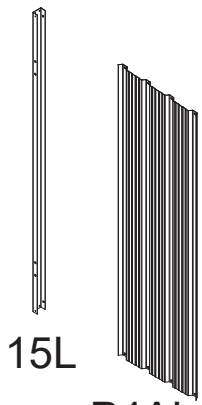
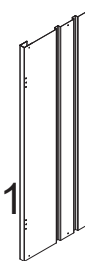

15L

P4AL

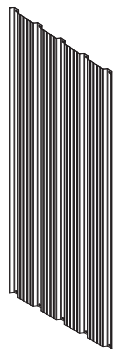

P1AL





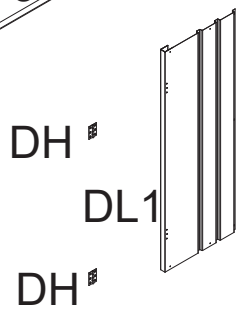
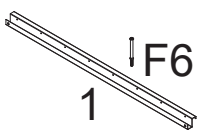
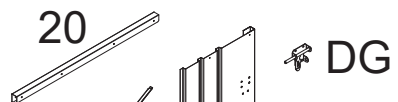
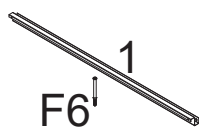
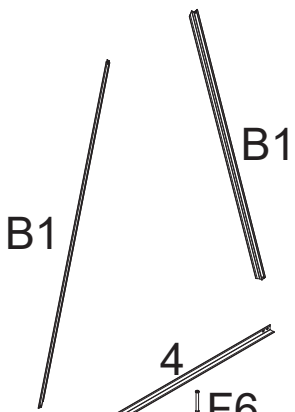
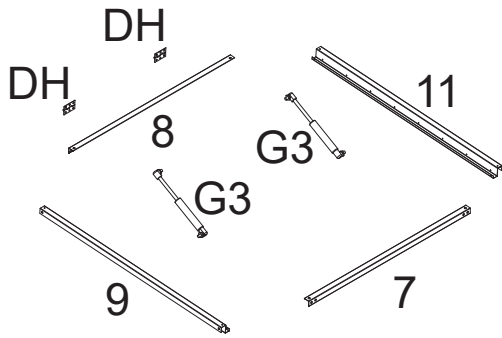
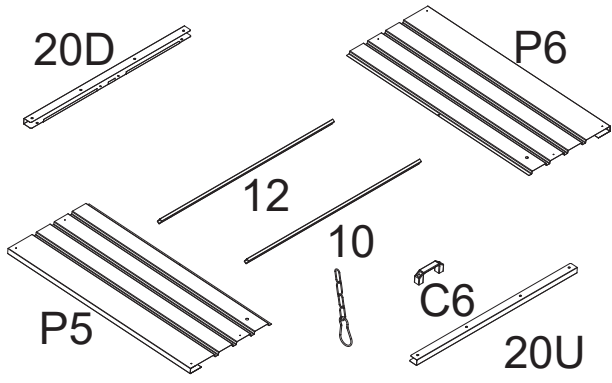

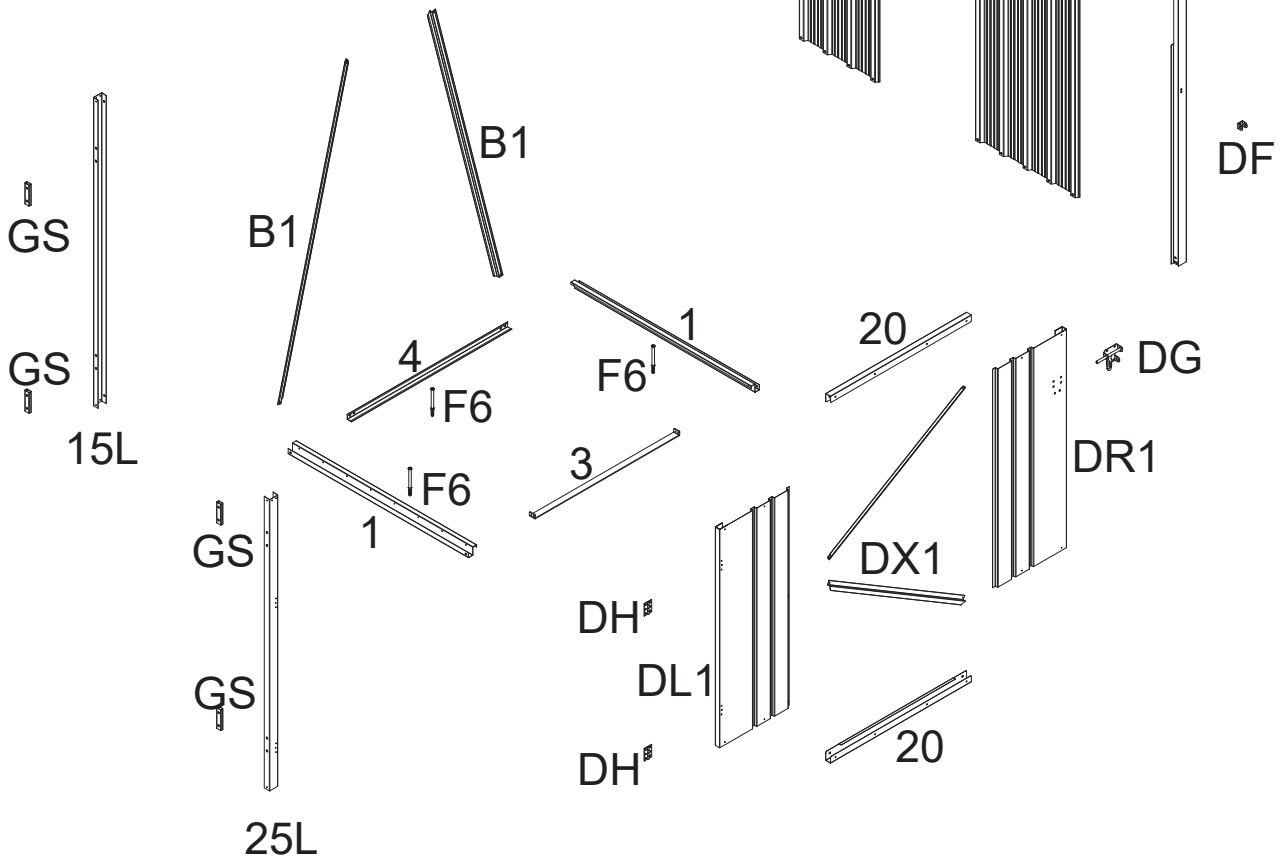
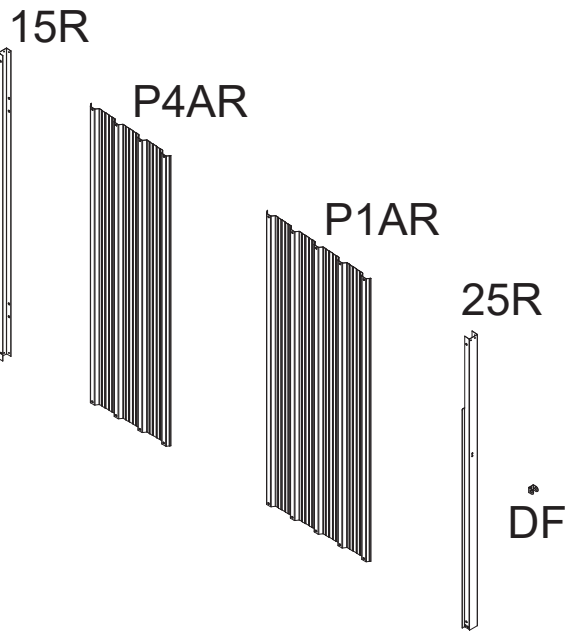
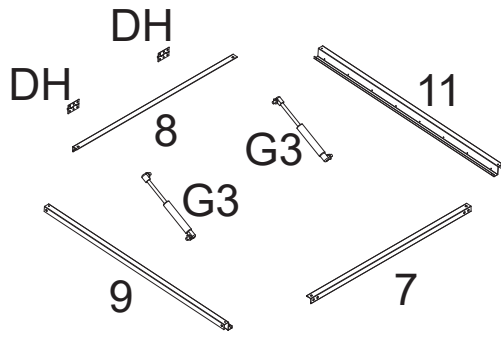
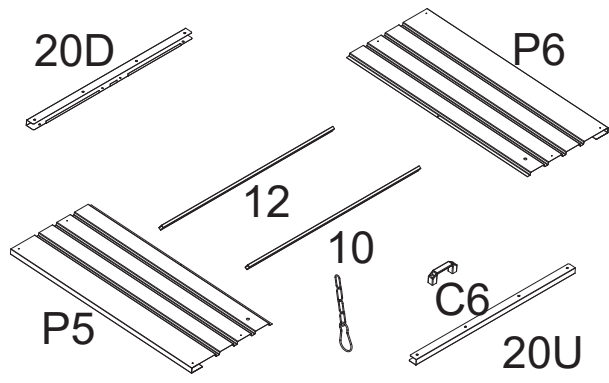

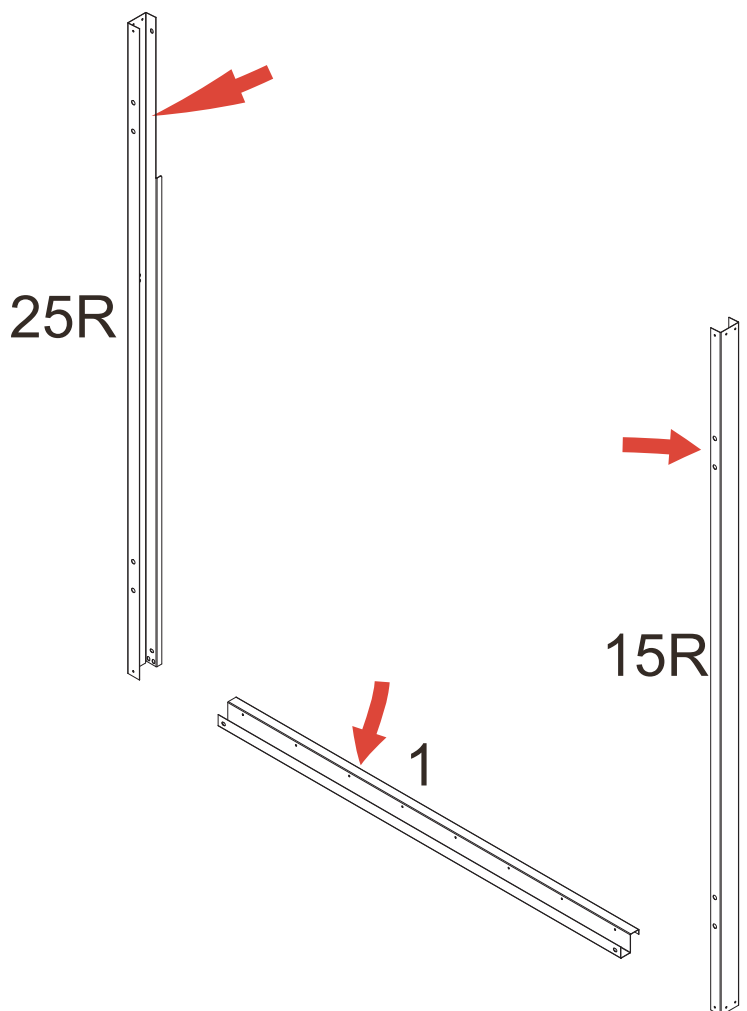
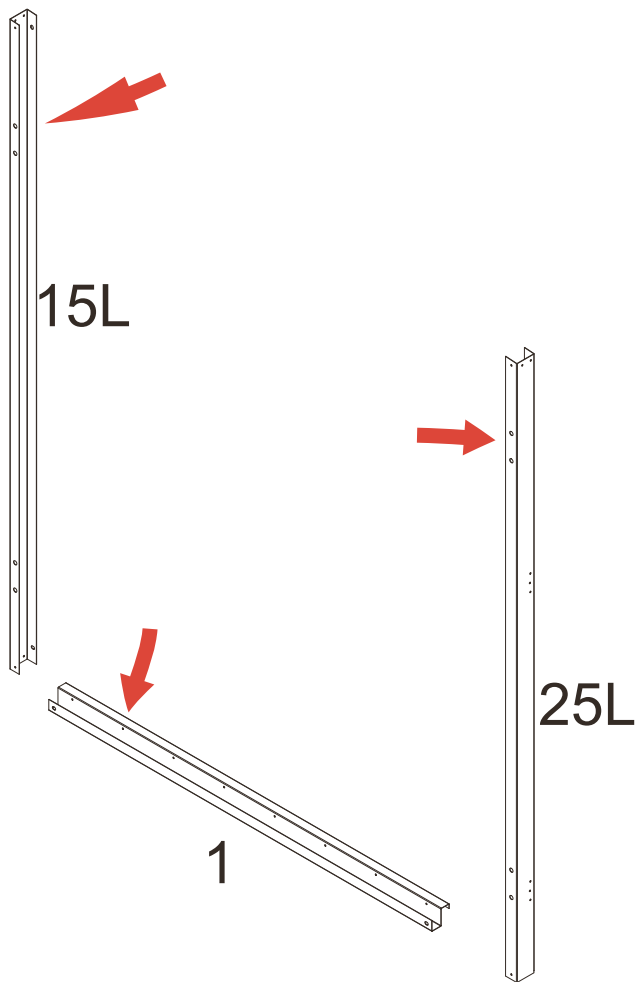

25L





Place as shown in the picture



NO.	PART	Qty.
1		2
15L		1
15R		1
25L		1
25R		1
F1		8
S2		8

This step can find a platform to lay the product flat for easier installation

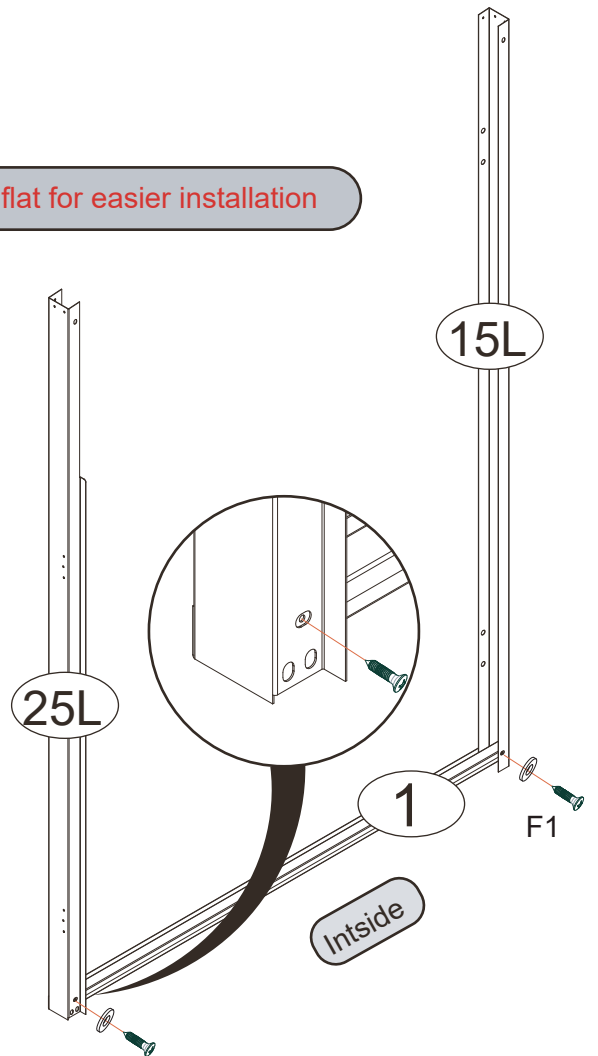
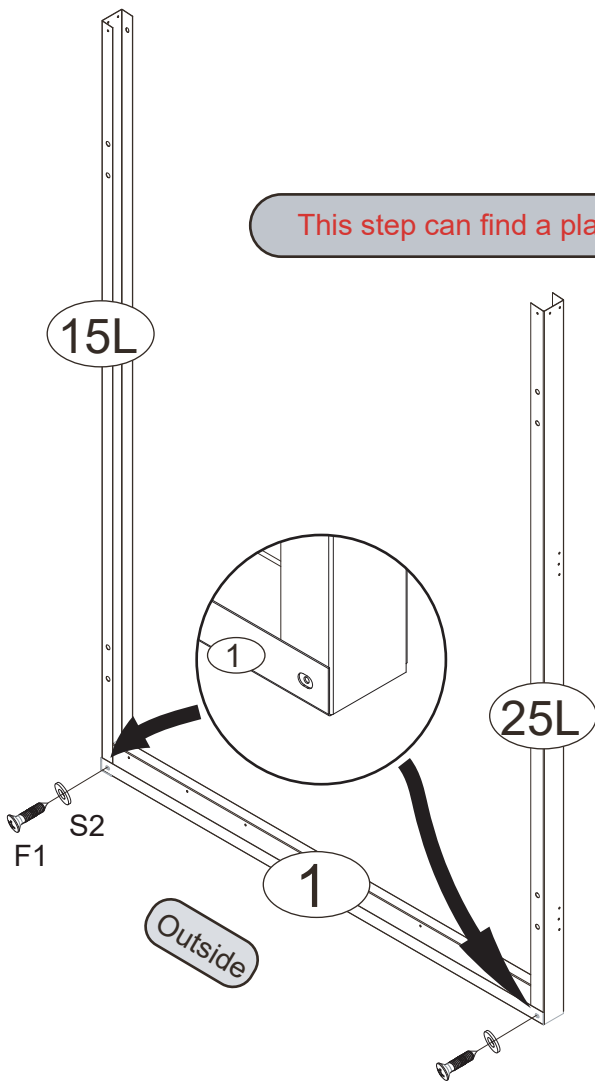

This step can find a platform to lay the product flat for easier installation

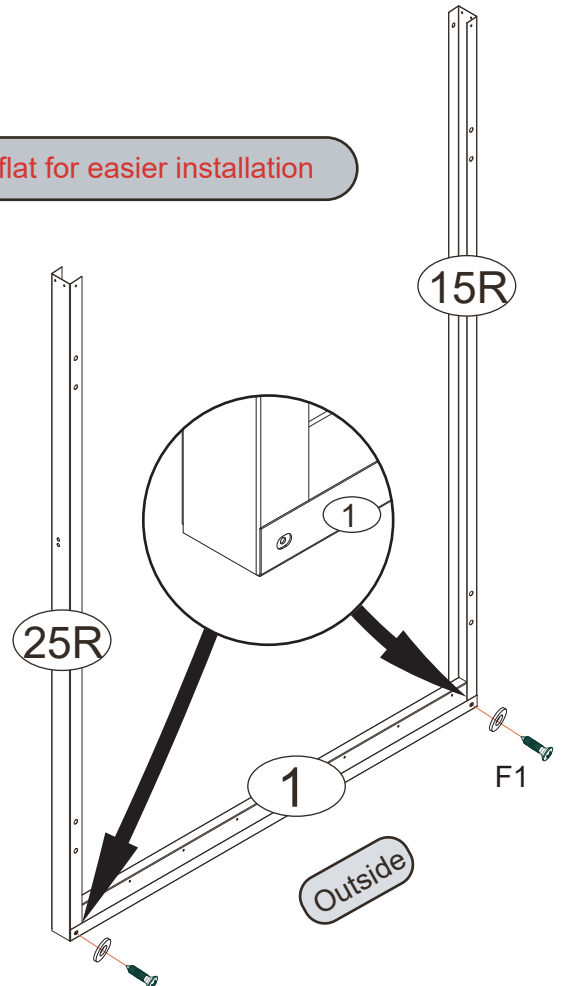
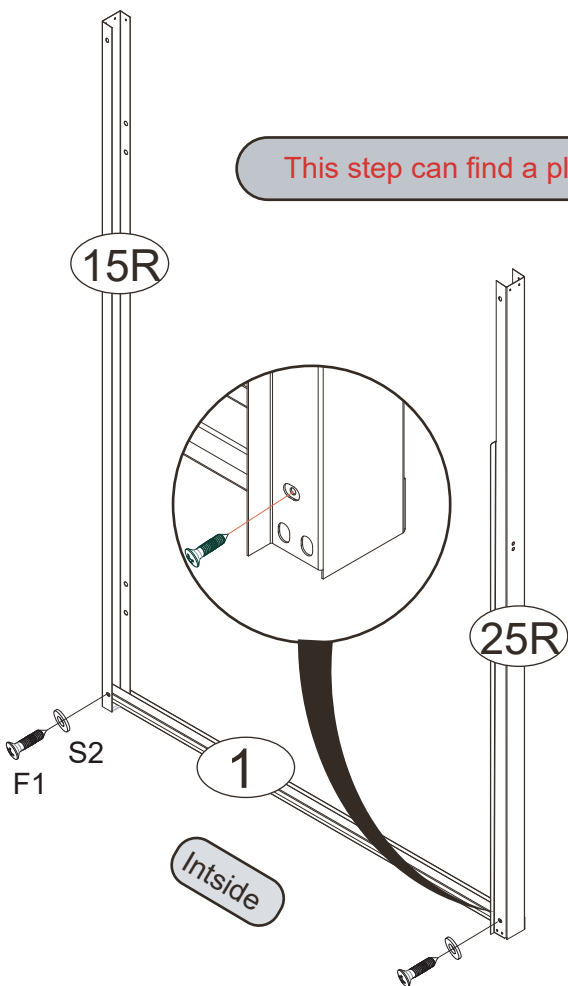

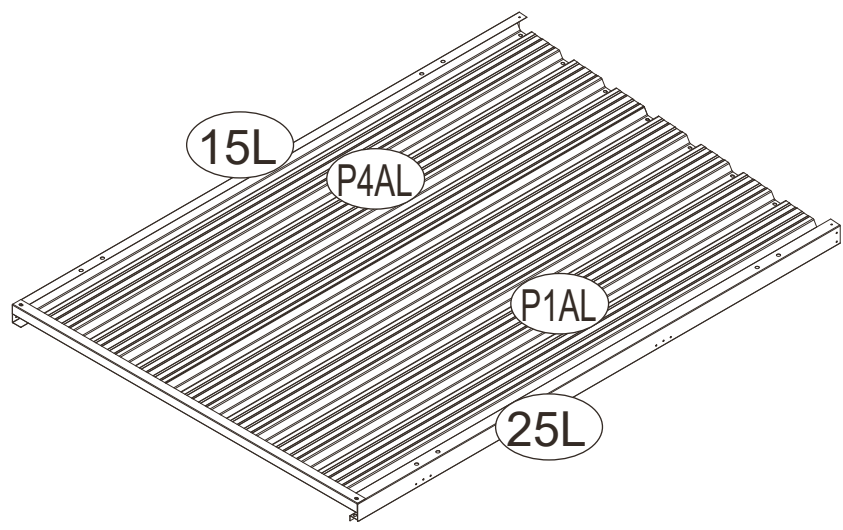
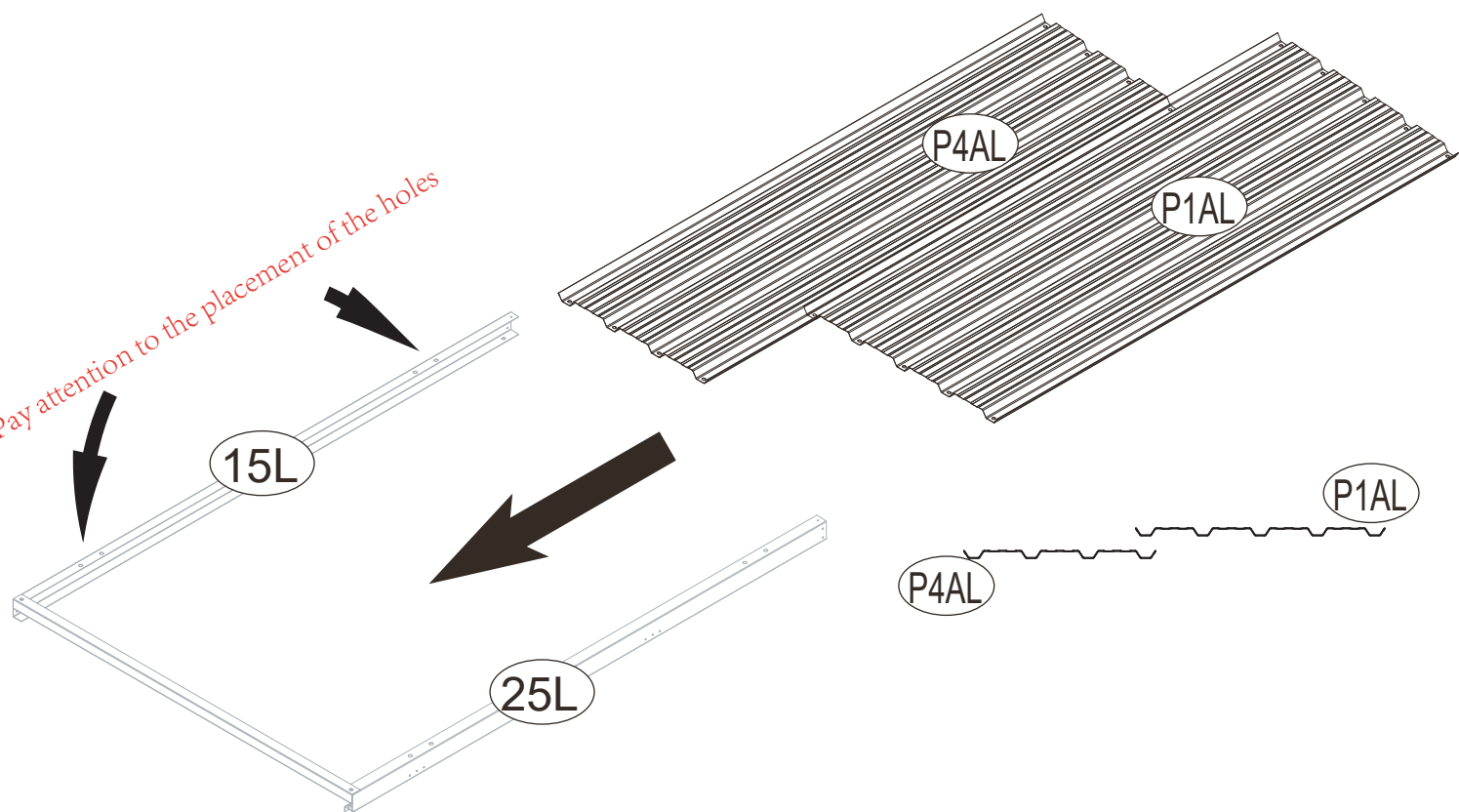

Pay attention to the placement of the holes

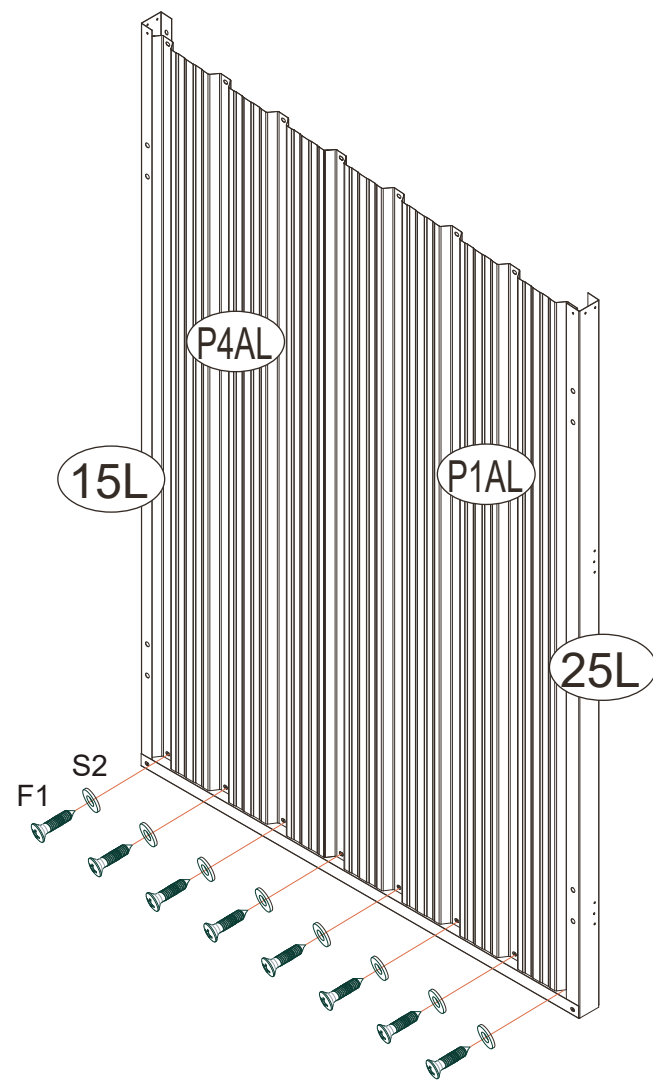

This way, it's easier to install

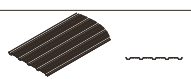
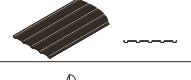

NO.	PART	Qty.
P1AL		1
P4AL		1
F1		8
S2		8

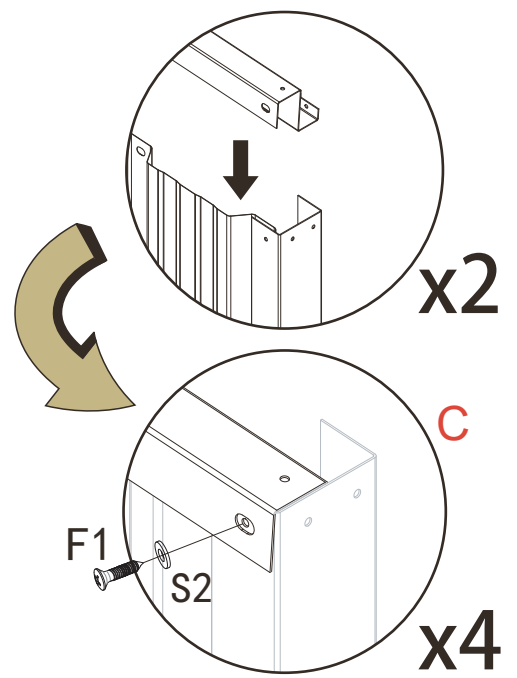
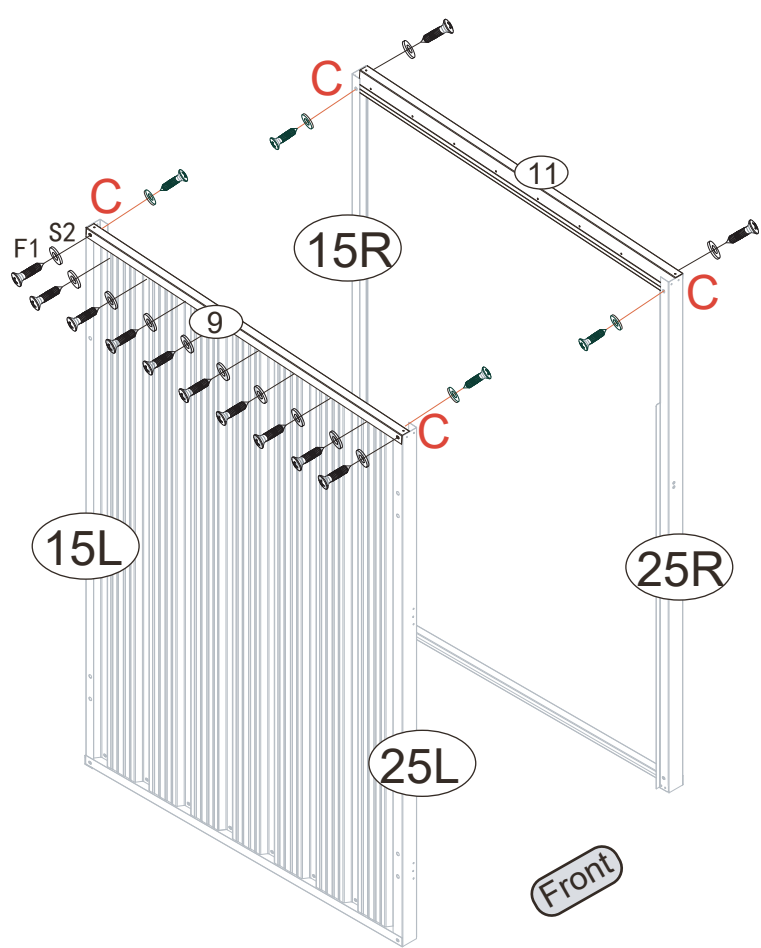

NO.	PART	Qty.
9		1
11		1
F1		16
S2		16

This step can find a platform to lay the product flat for easier installation

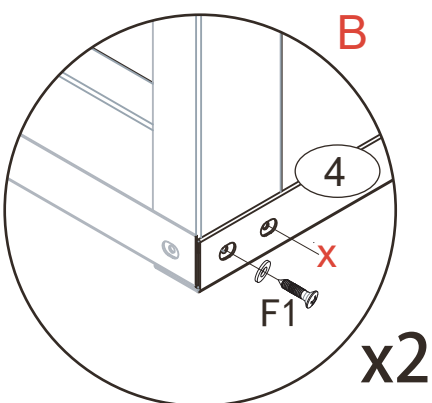
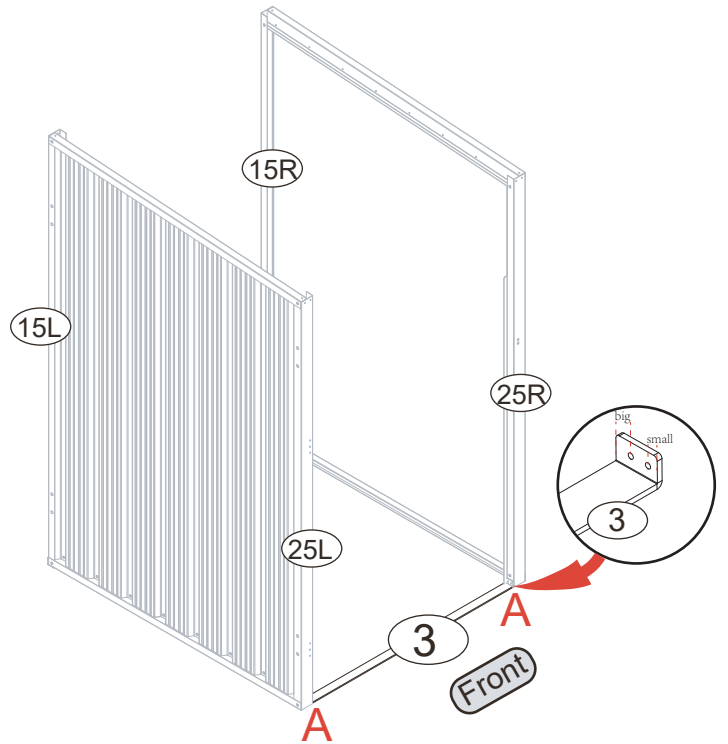
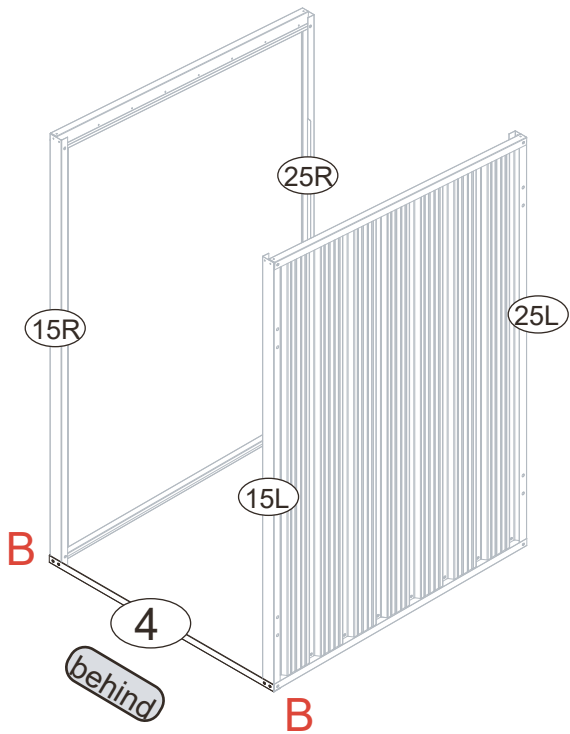

NO.	PART	Qty.
3		1
4		1
F1		6
S2		6

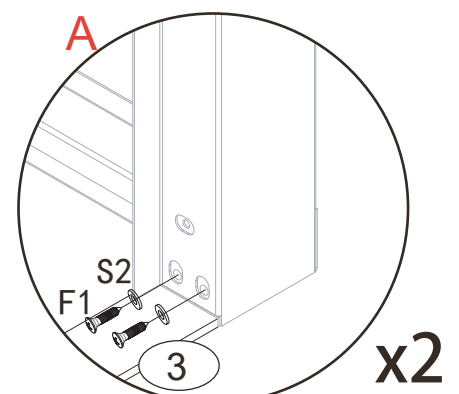

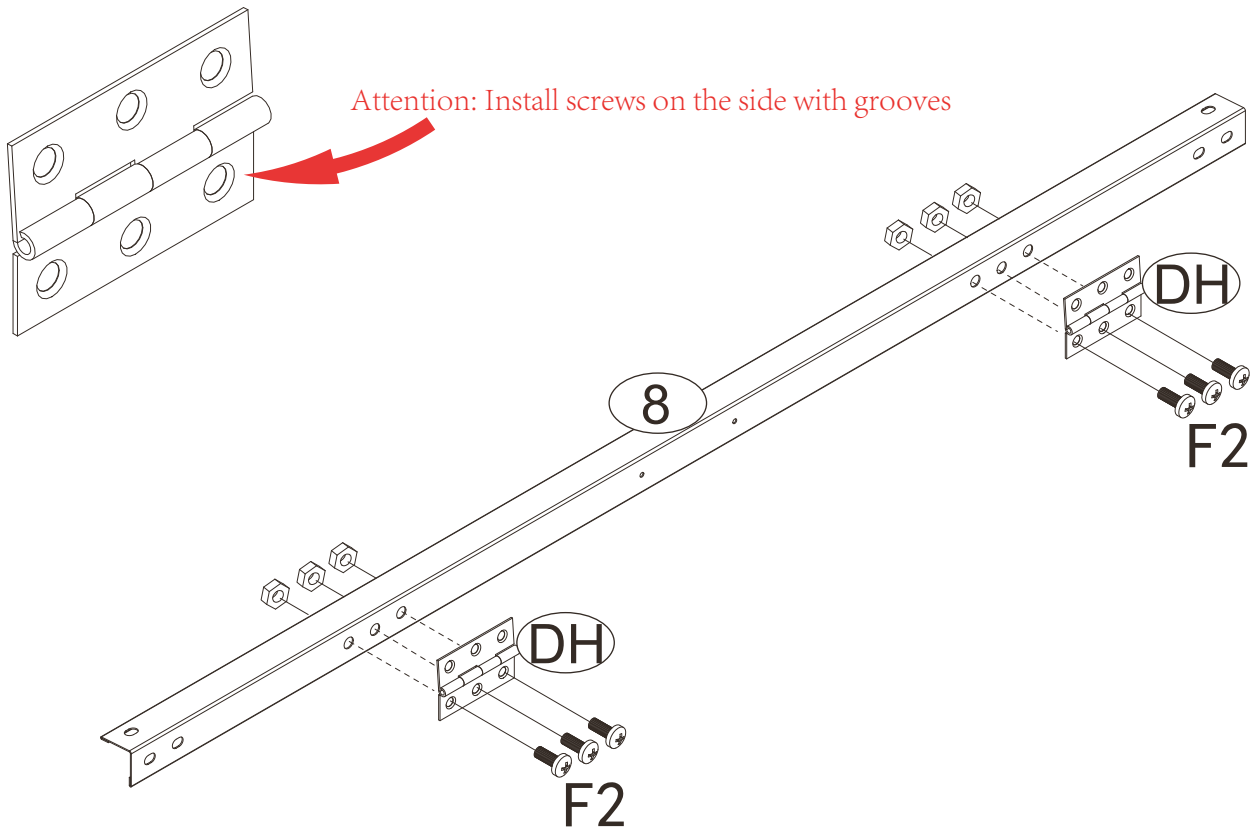

NO.	PART	Qty.
F2		6

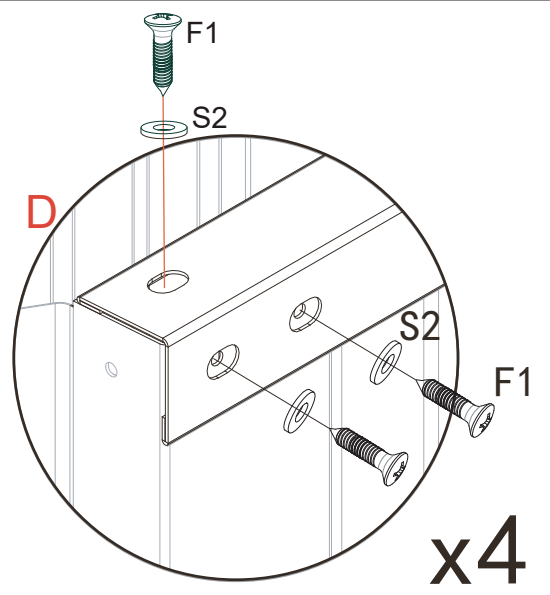
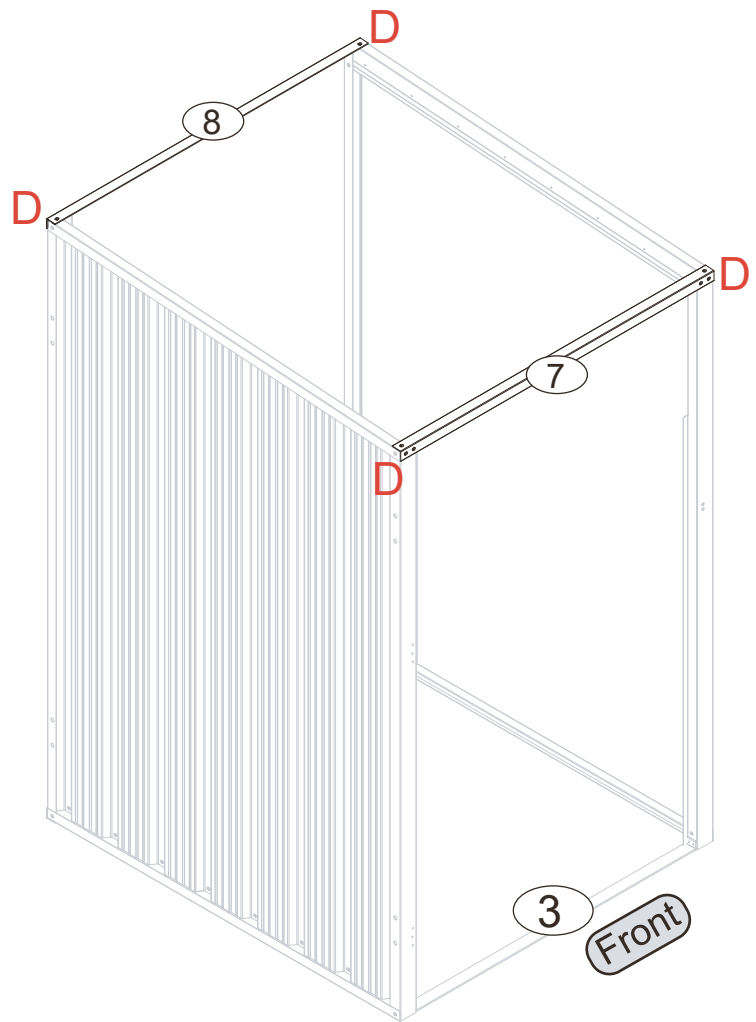

NO.	PART	Qty.
7		1
8		1
F1		12
S2		12

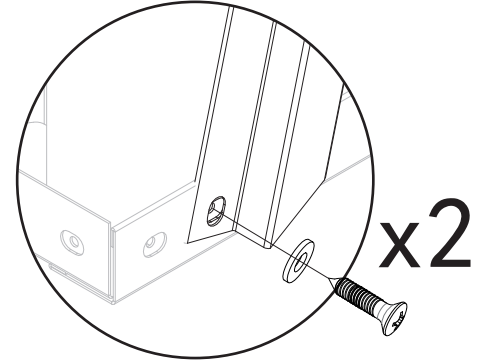
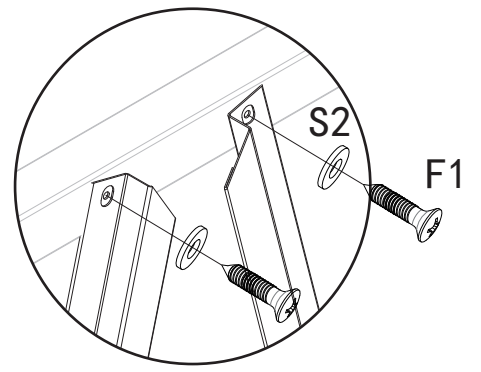
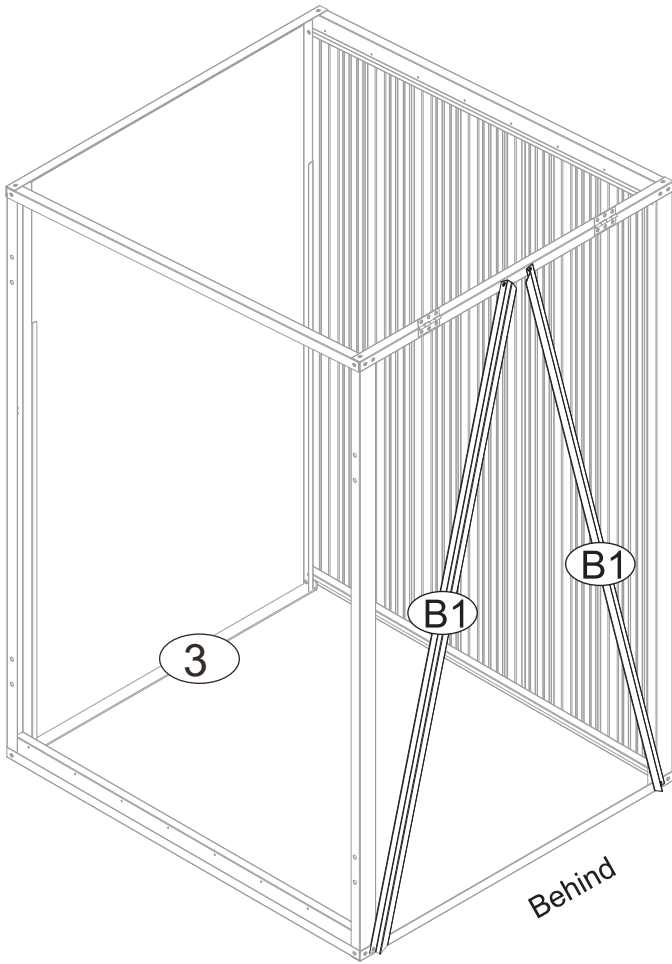

NO.	PART	Qty.
B1		2
F1		4
S2		4

NO.	PART	Qty.
F4		2
F1		20
S2		12

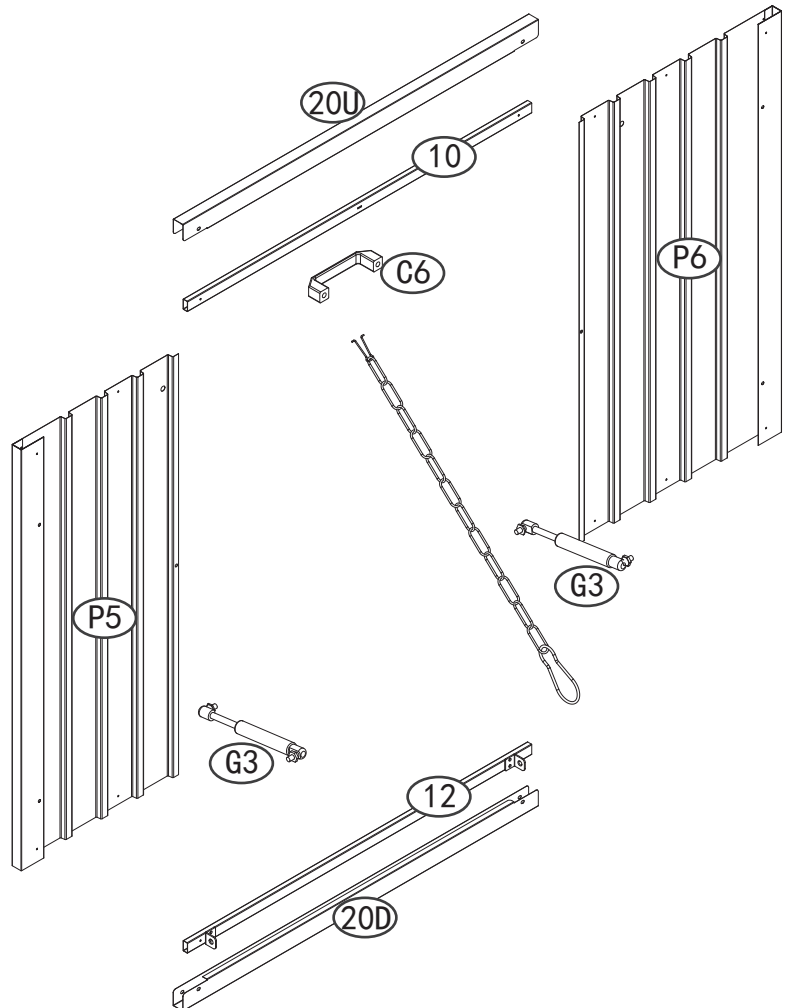

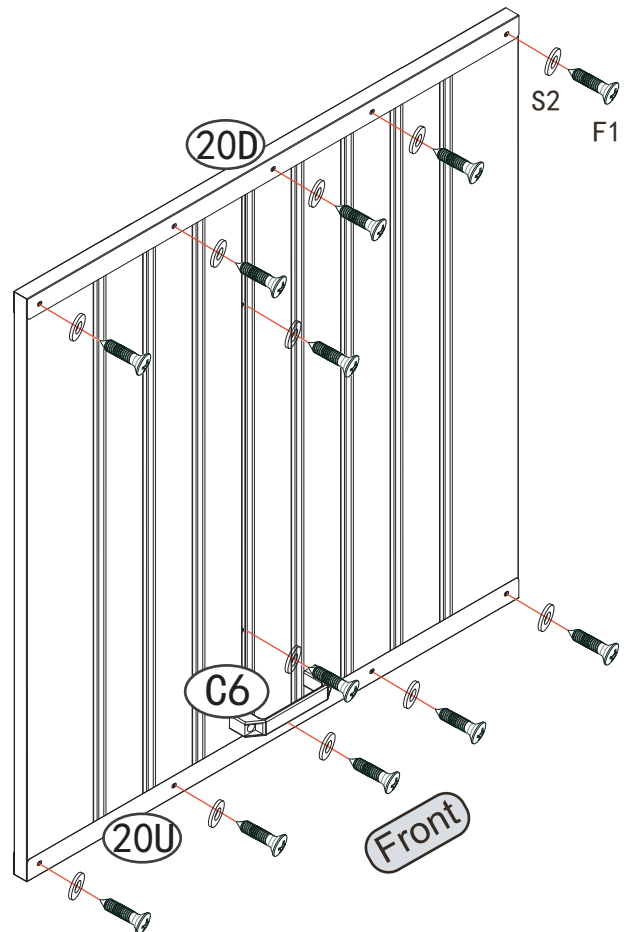
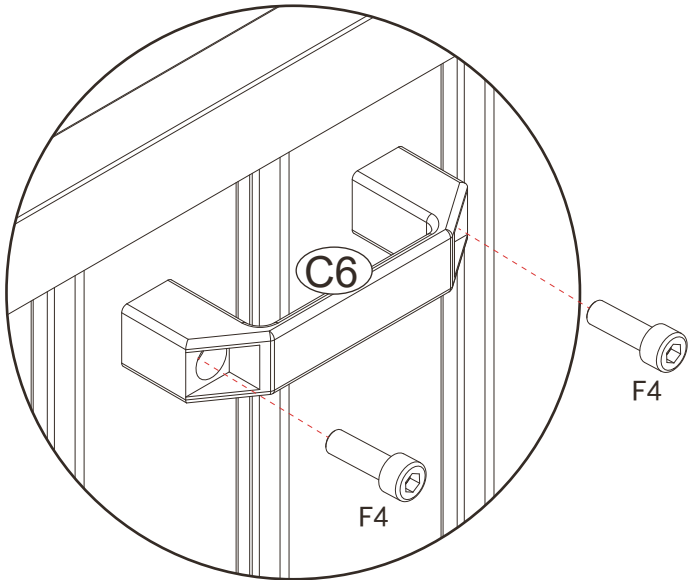
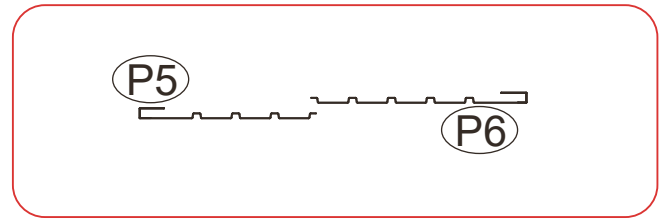
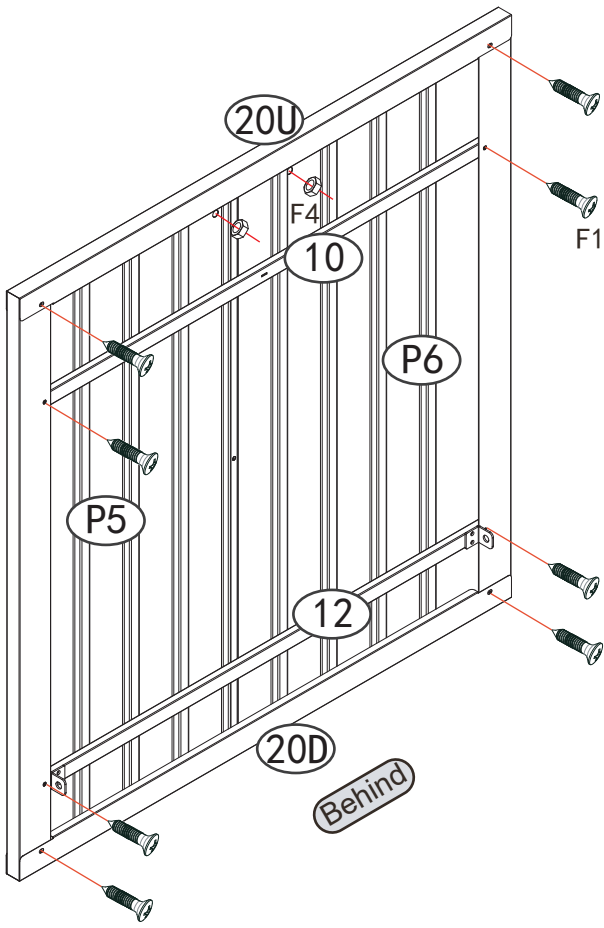

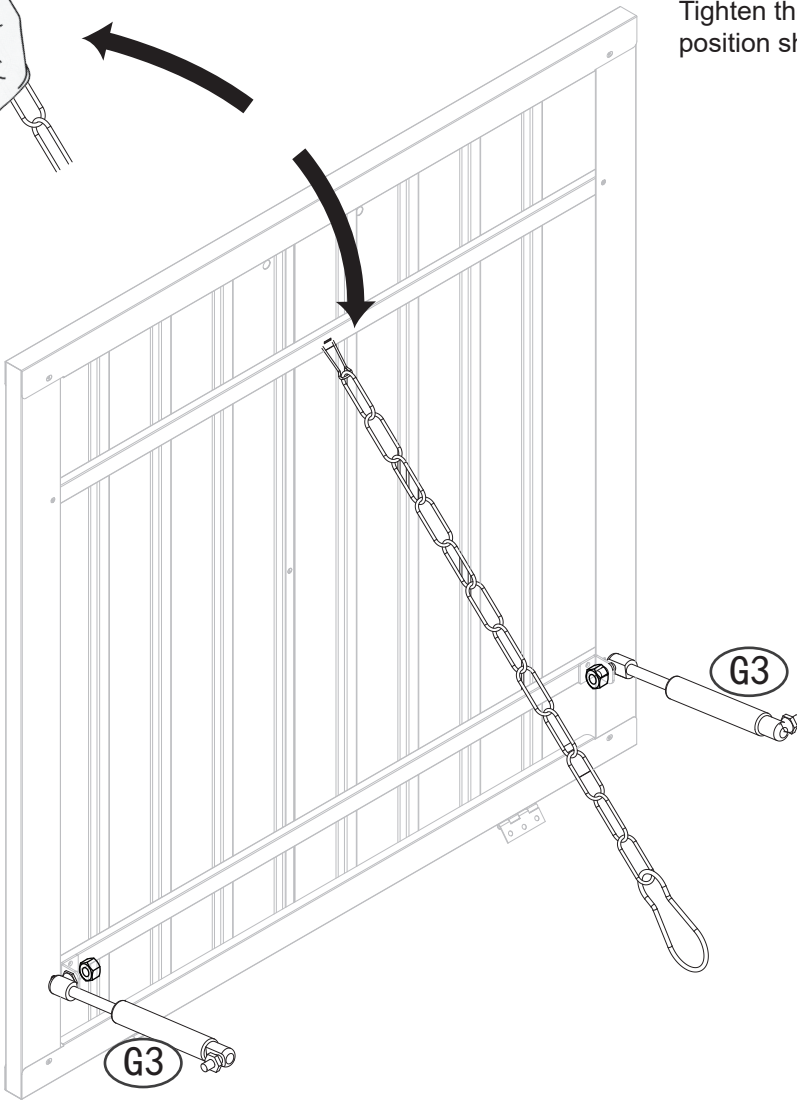
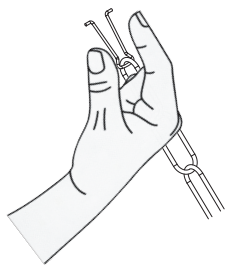

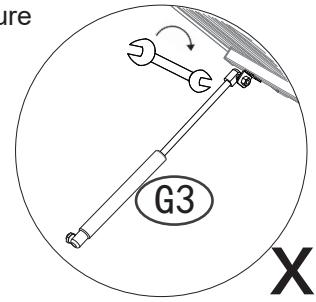

Tighten the bolts with a wrench according to the position shown in the figure



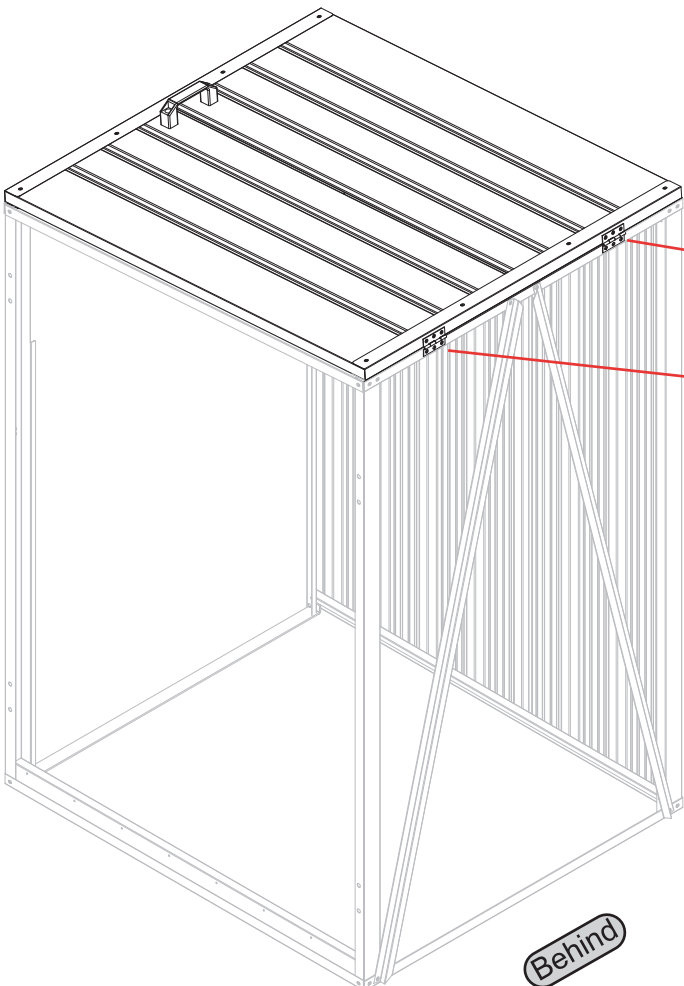

x2

NO.	PART	Qty.
G3		2
M8		2
		1

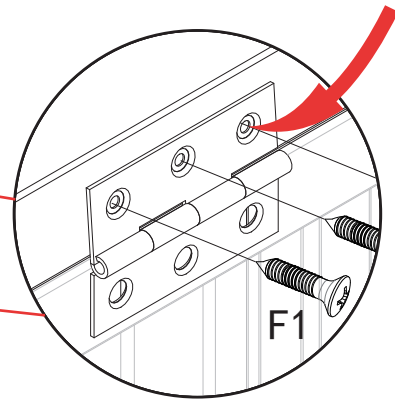

Attention: Install screws on the side with grooves





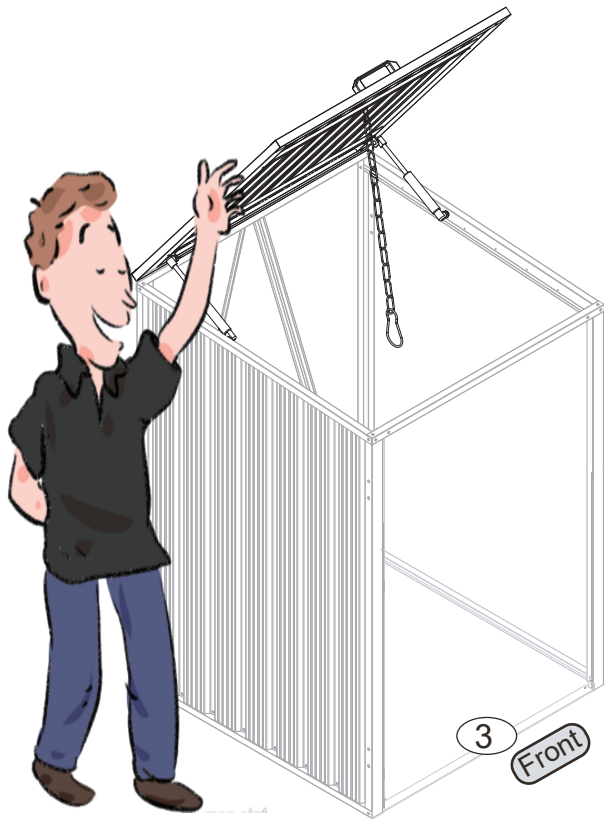

NO.	PART	Qty.
F1		6

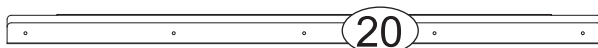
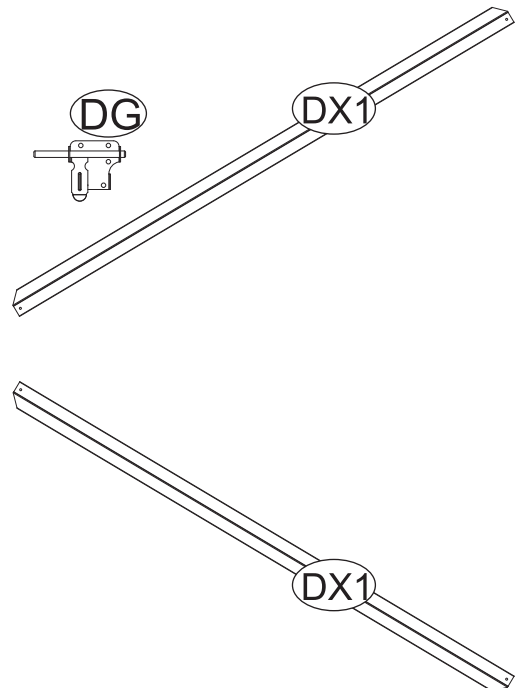
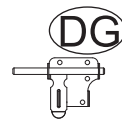
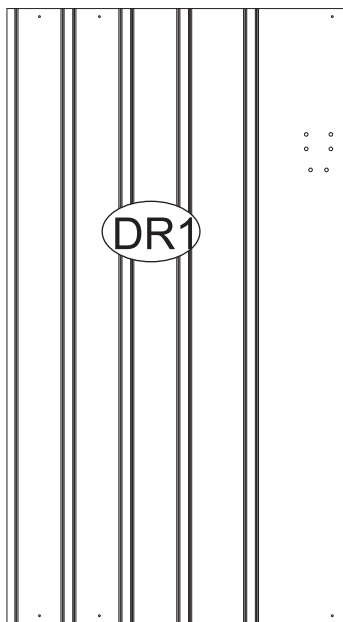
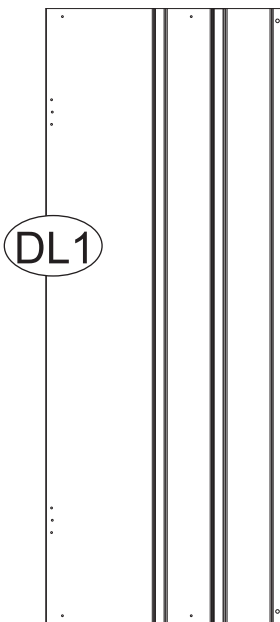
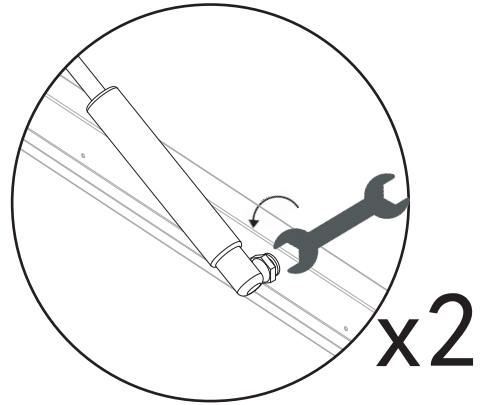

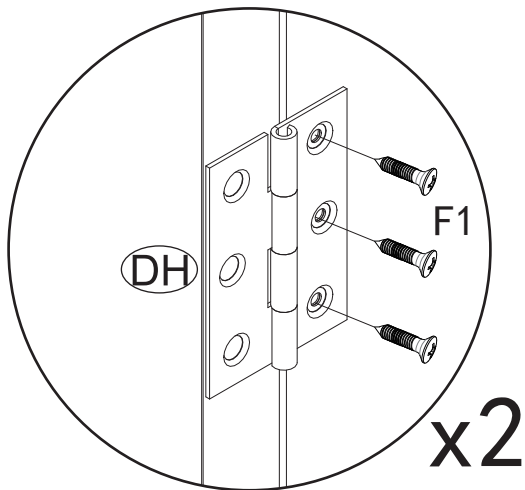
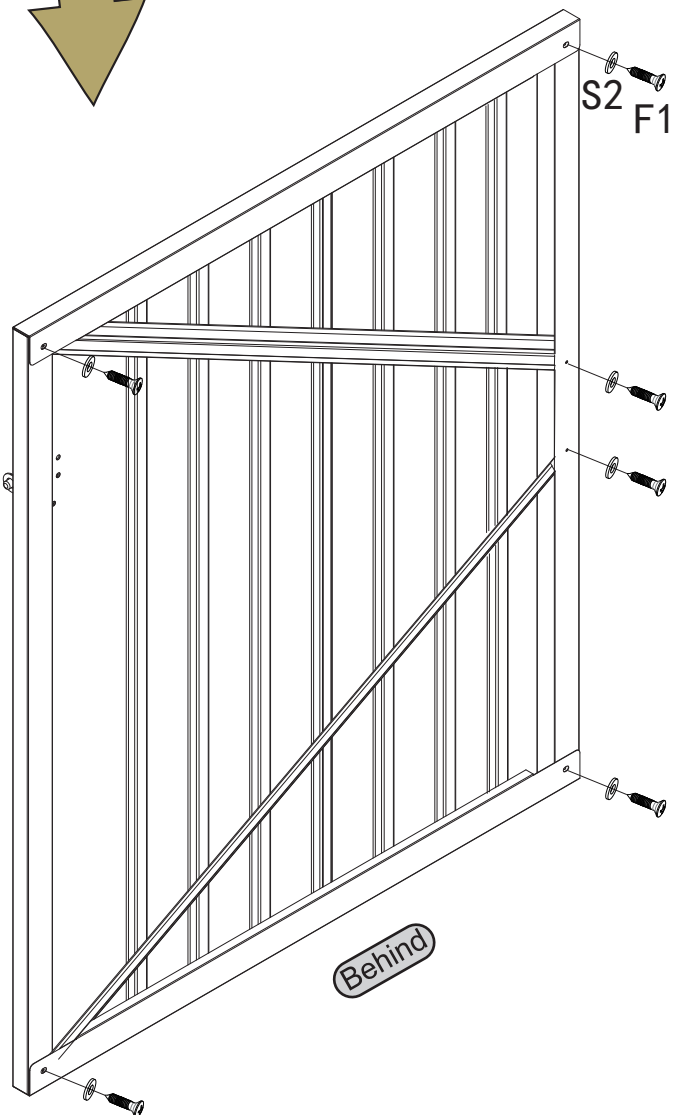
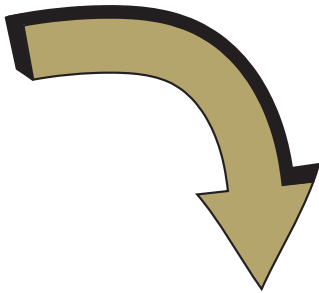
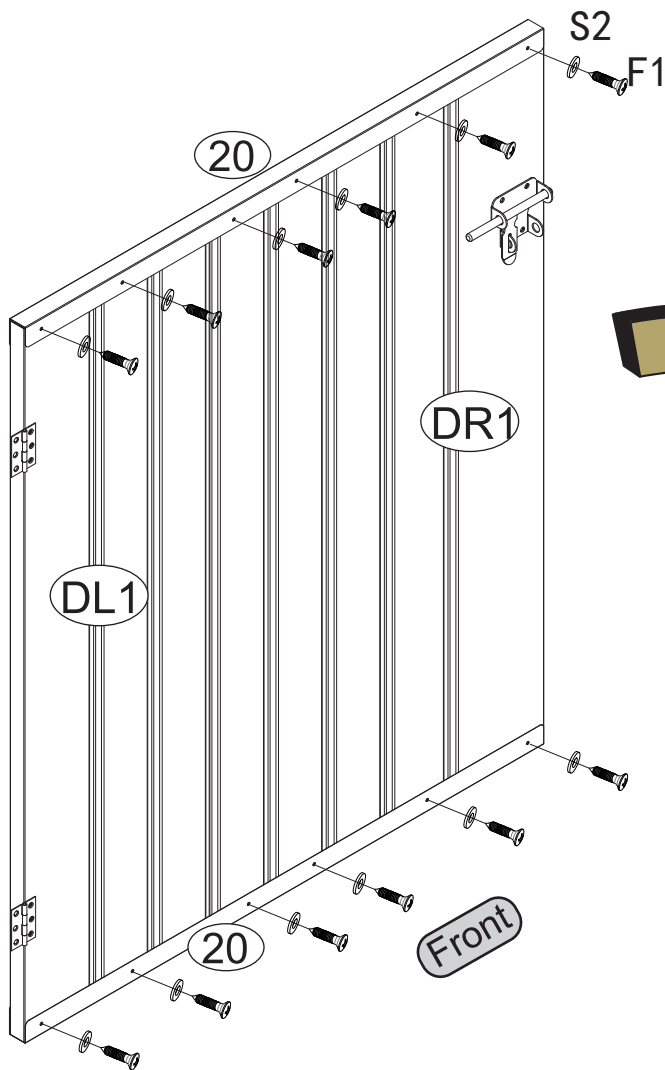
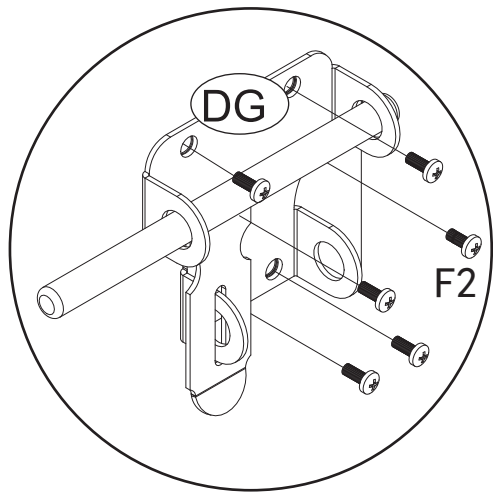
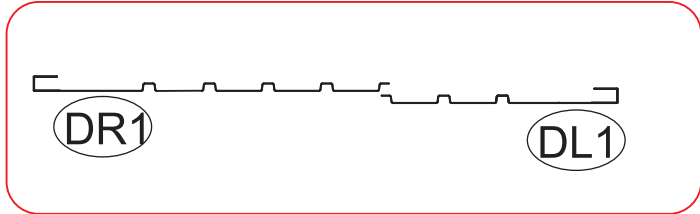
Tighten the bolts with a wrench according to the position shown in the figure





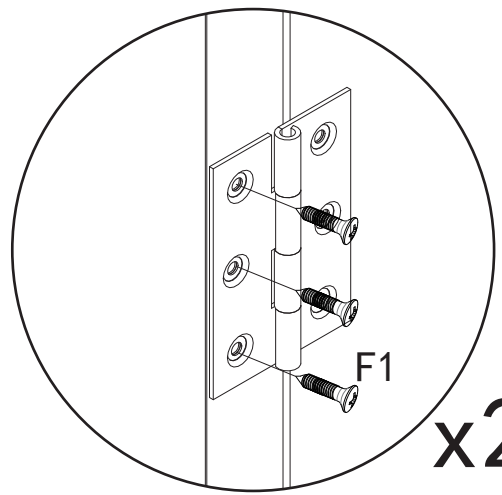
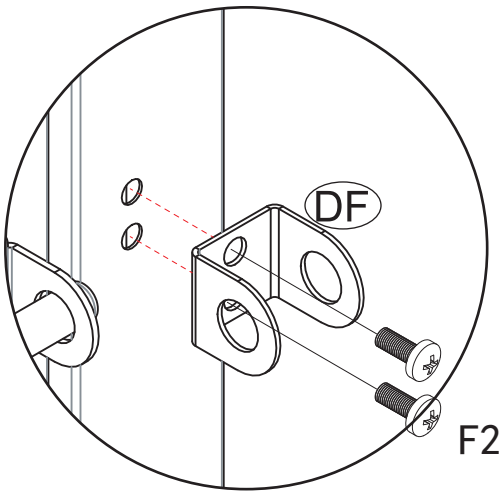

NO.	PART	Qty.
F1		24
S2		18
F2		6



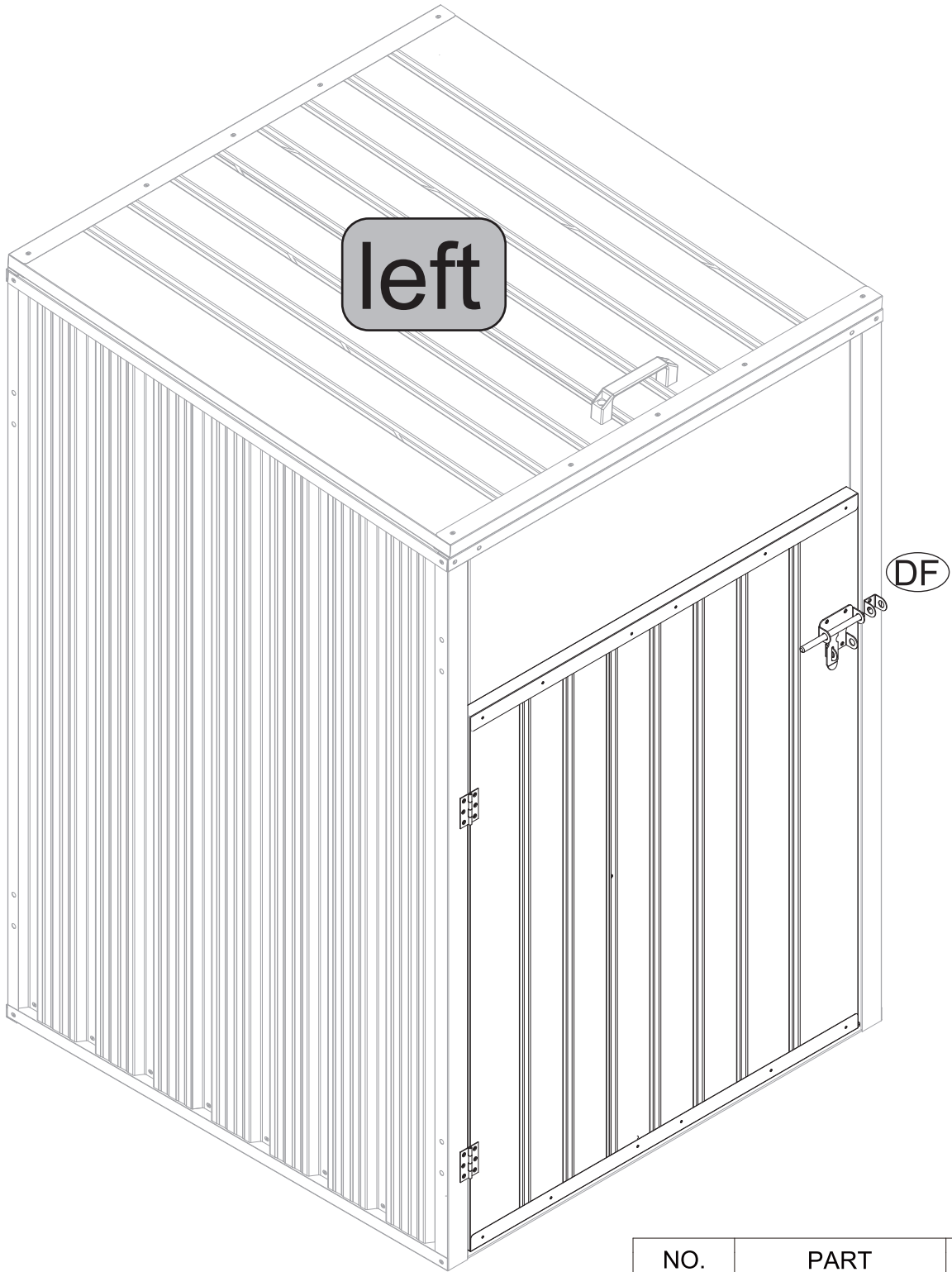

x2

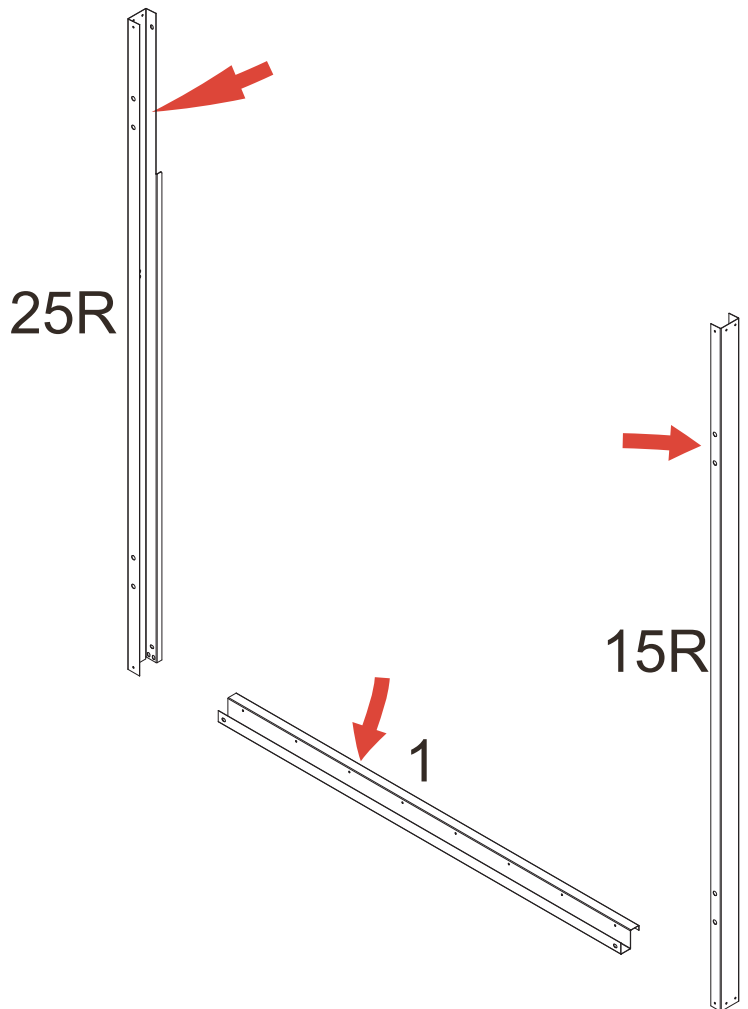
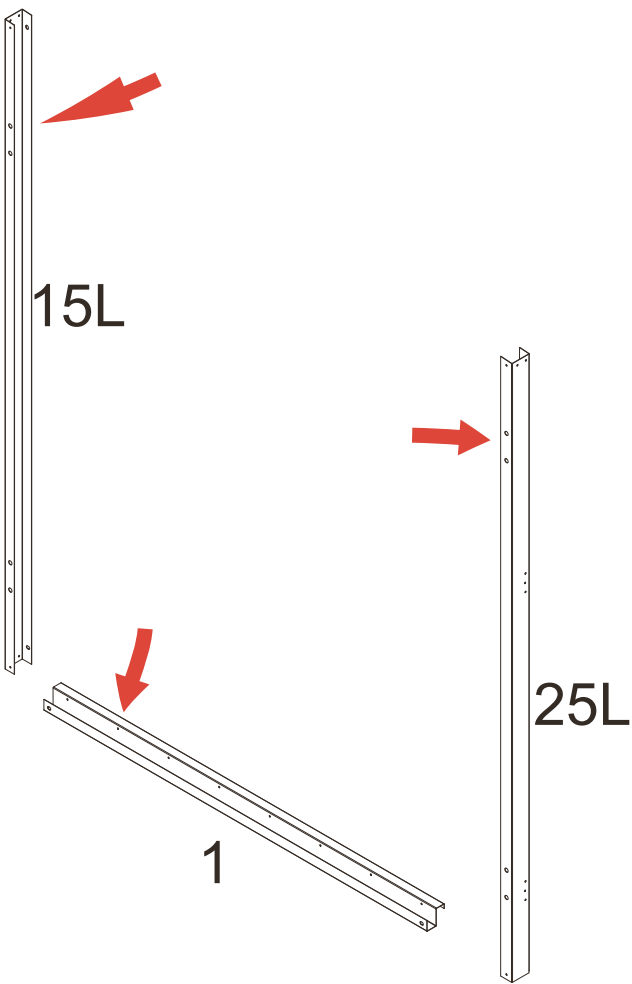

NO.	PART	Qty.
F1		6
F2		2

Place as shown in the picture

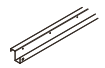
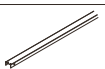
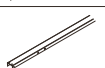
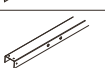
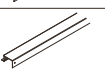

NO.	PART	Qty.
1		2
15L		1
15R		1
25L		1
25R		1
F1		8
S2		8

This step can find a platform to lay the product flat for easier installation

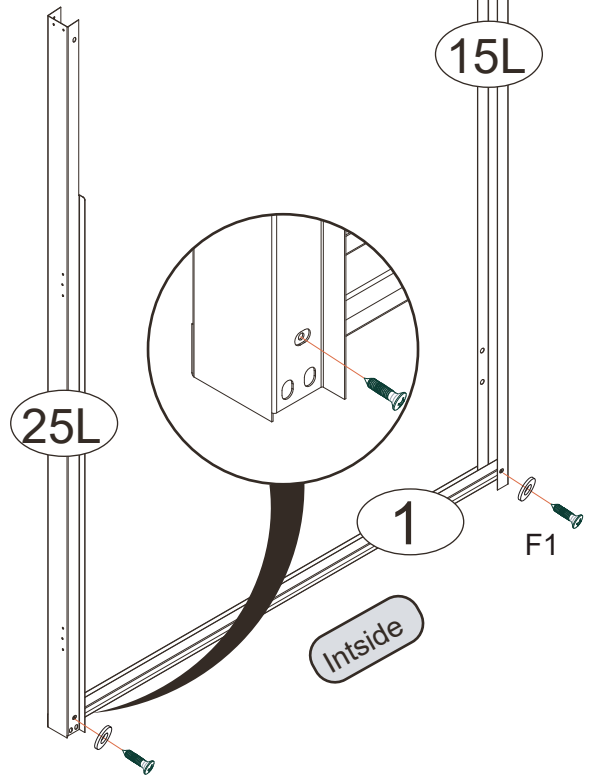
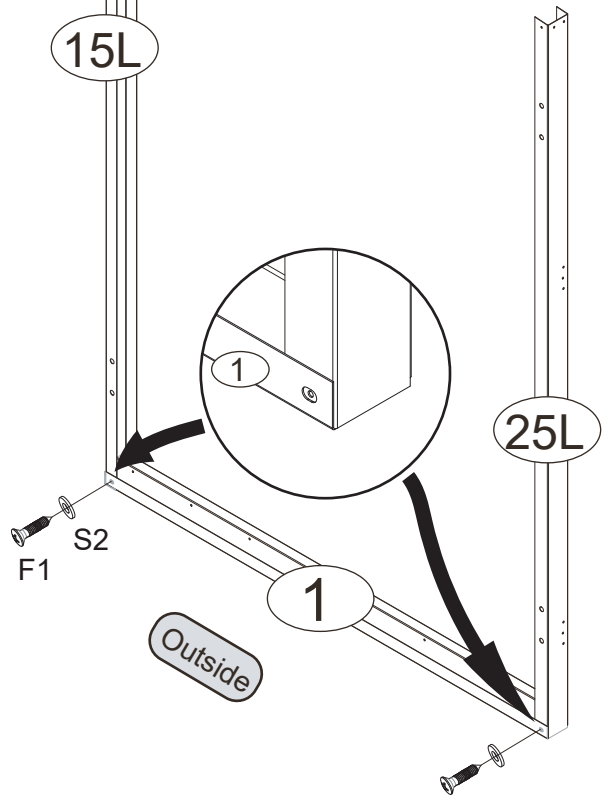

This step can find a platform to lay the product flat for easier installation

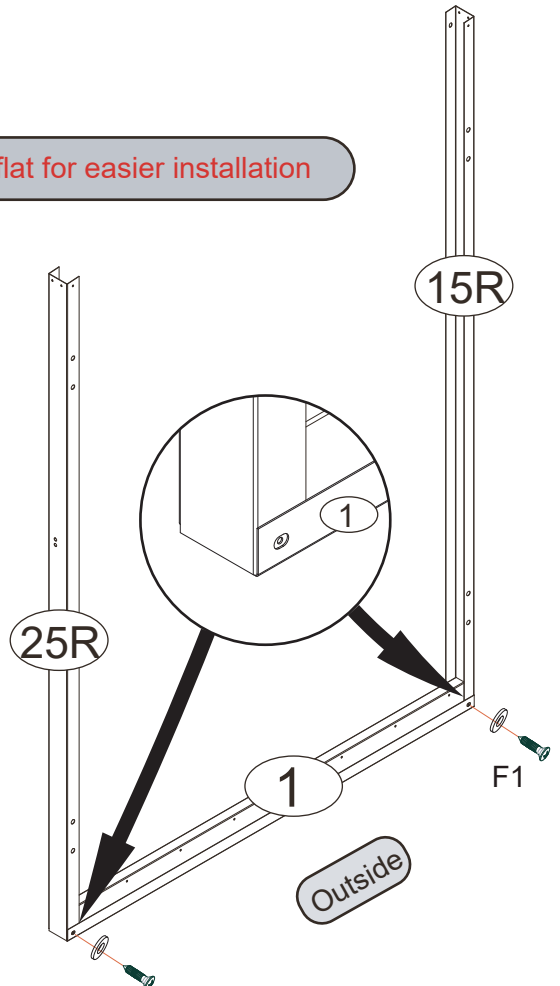
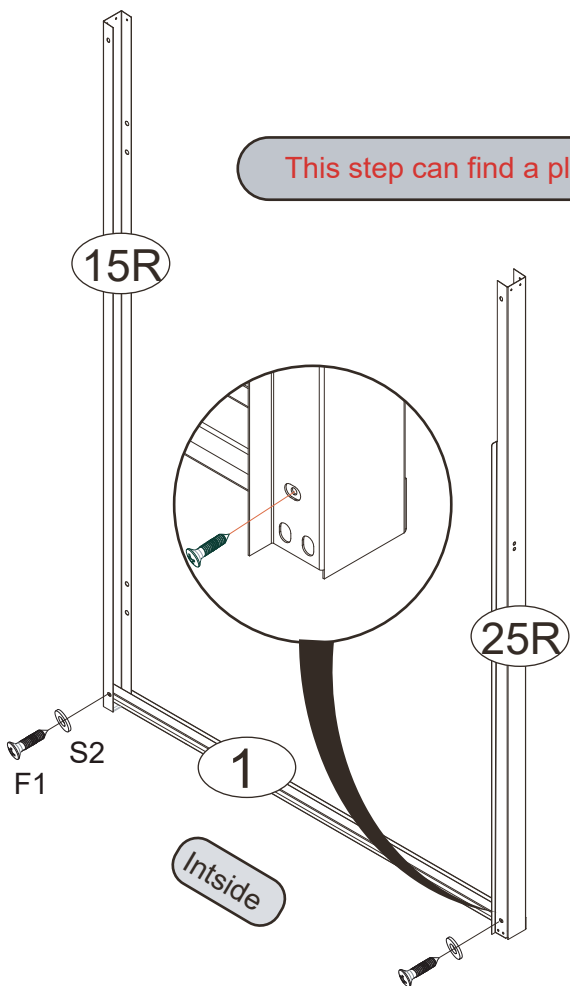

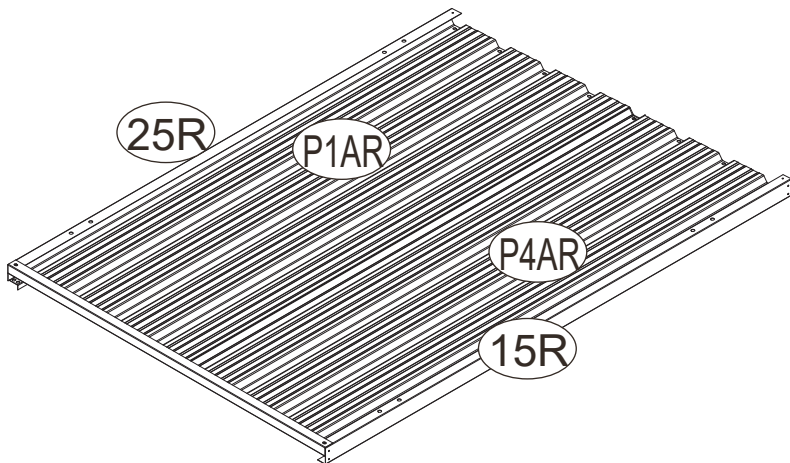
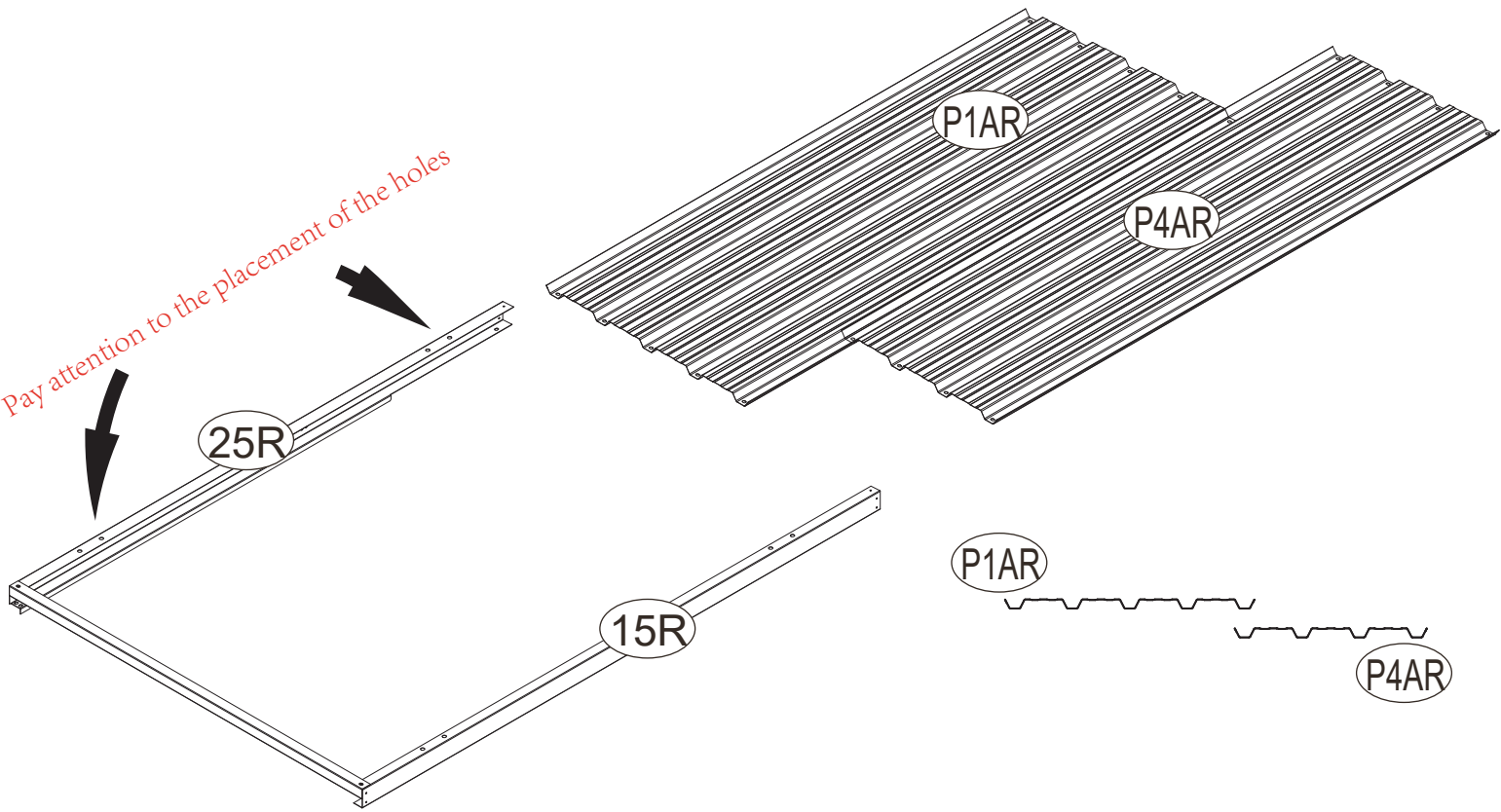

Pay attention to the placement of the holes

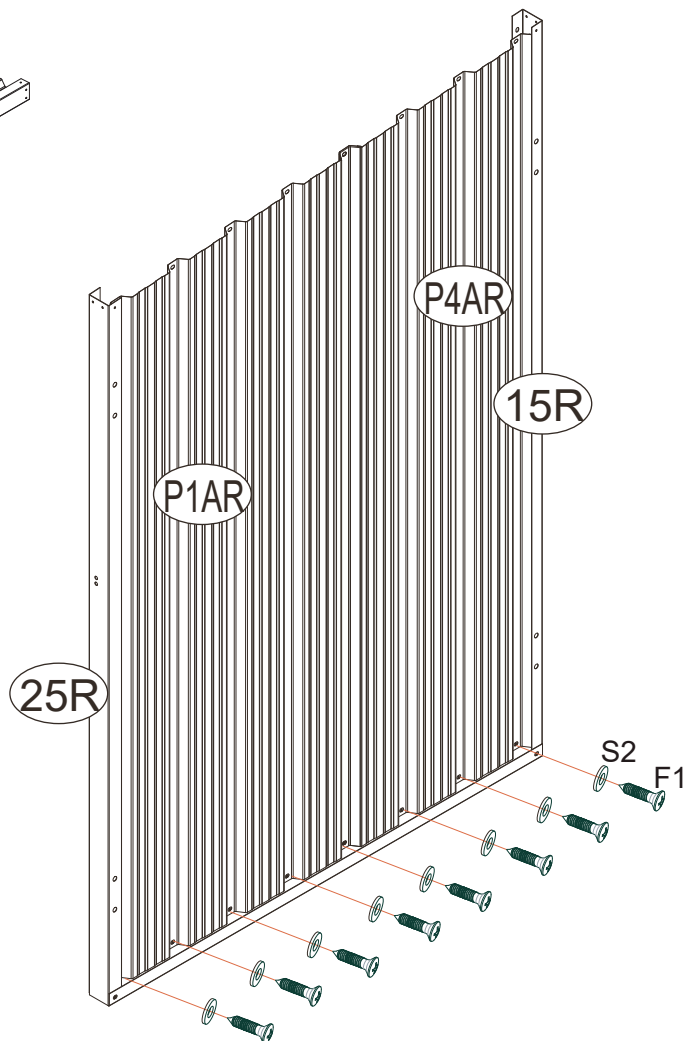

This way, it's easier to install

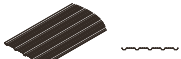
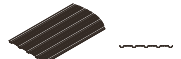

NO.	PART	Qty.
P1AR		1
P4AR		1
F1		8
S2		8

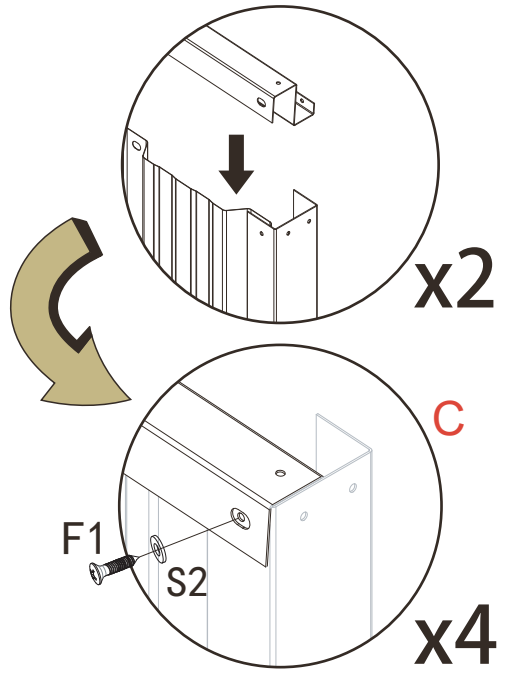
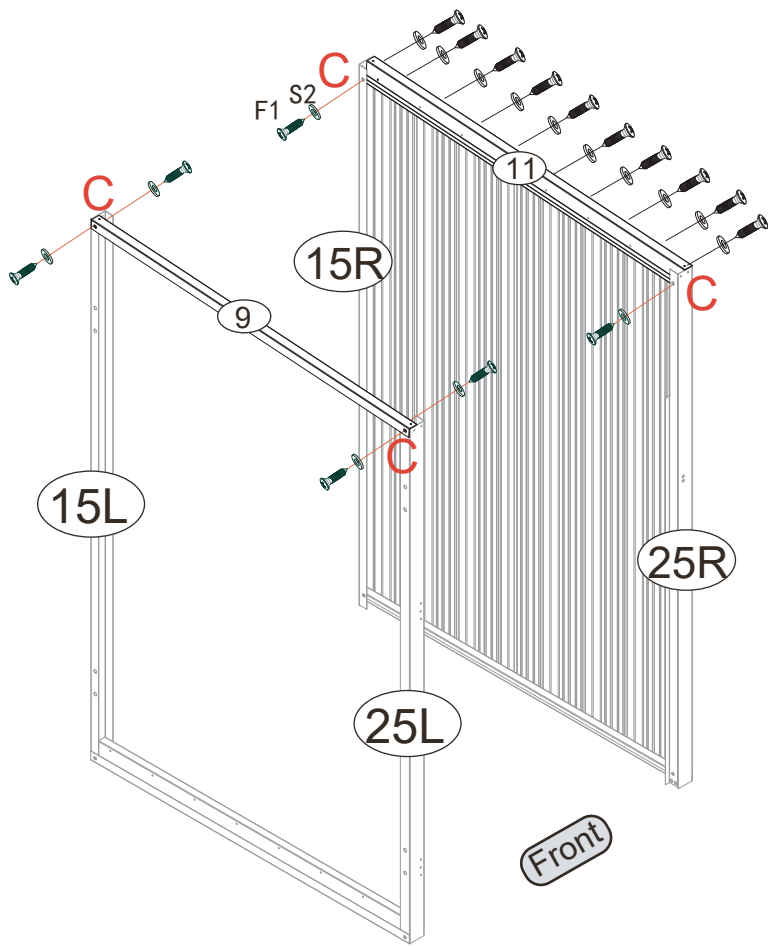

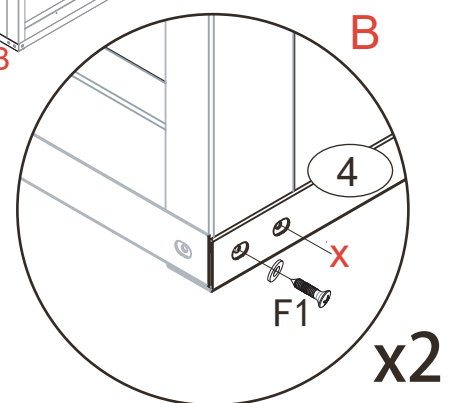
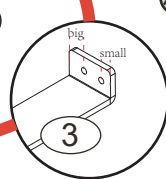
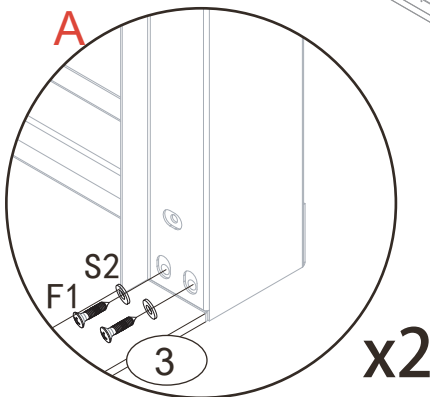
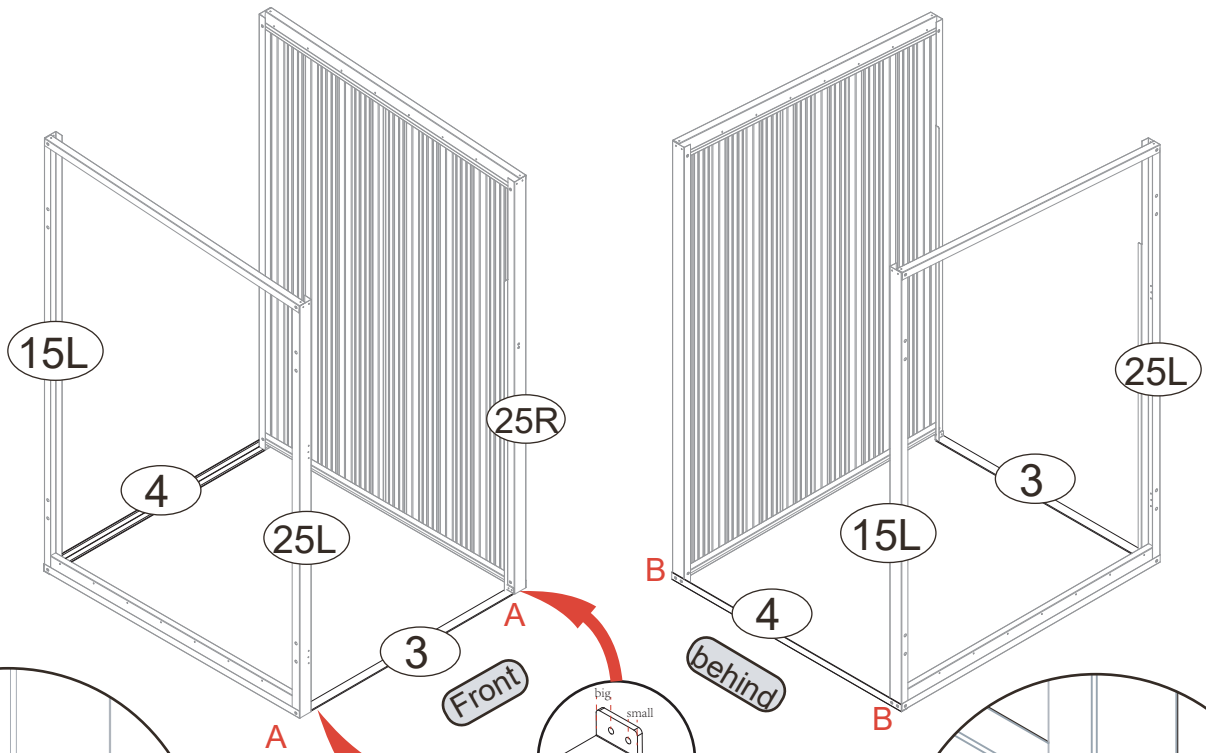

NO.	PART	Qty.
9		1
11		1
F1		16
S2		16

This step can find a platform to lay the product flat for easier installation



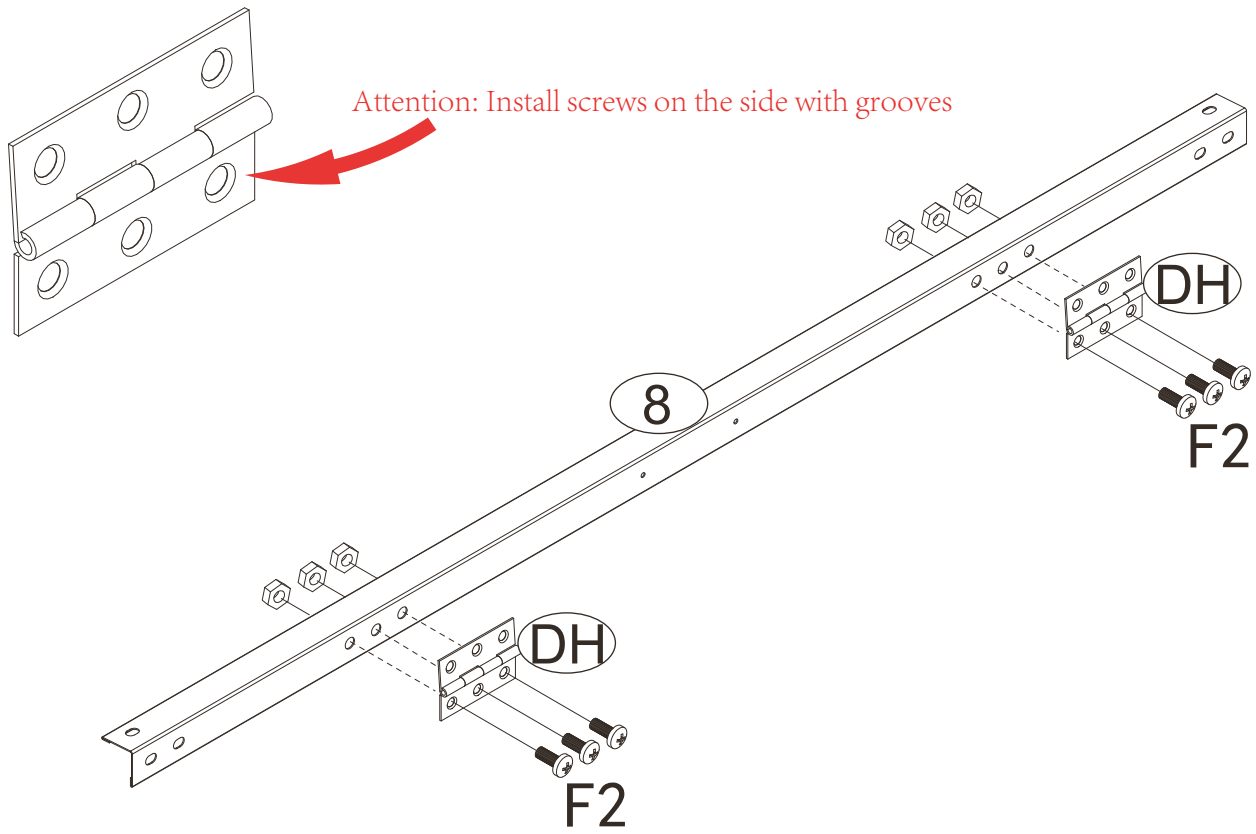



NO.	PART	Qty.
3		1
4		1
F1		6
S2		6

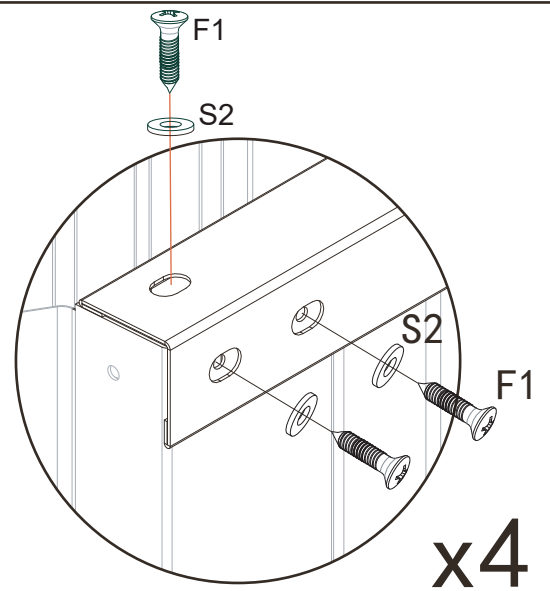
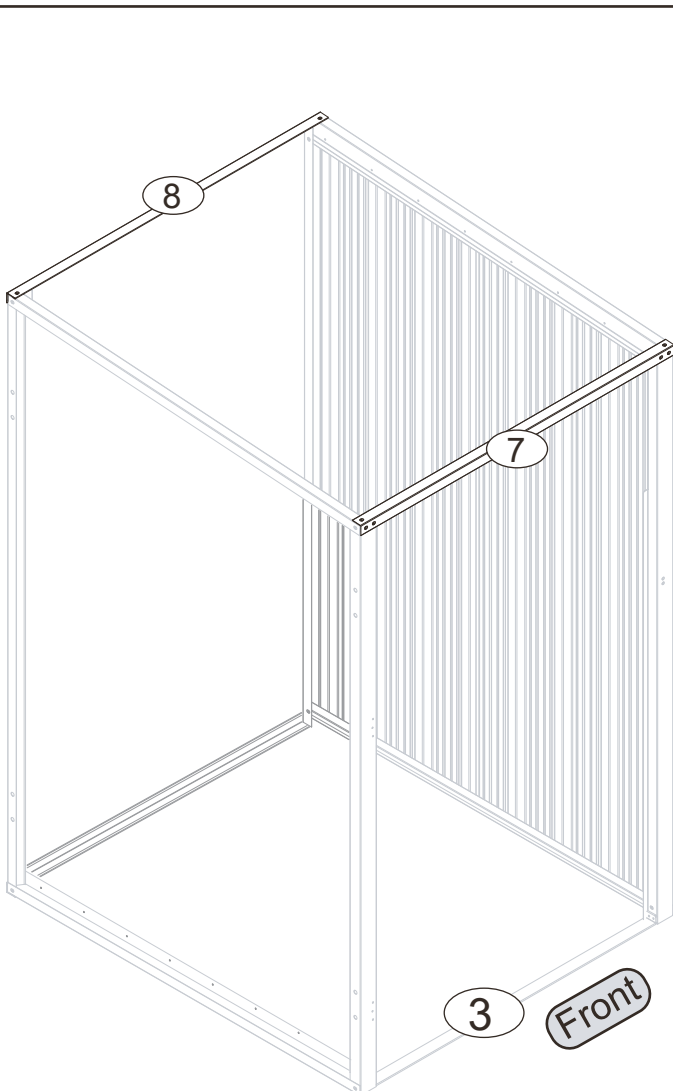

NO.	PART	Qty.
F2		6



NO.	PART	Qty.
7		1
8		1
F1		12
S2		12

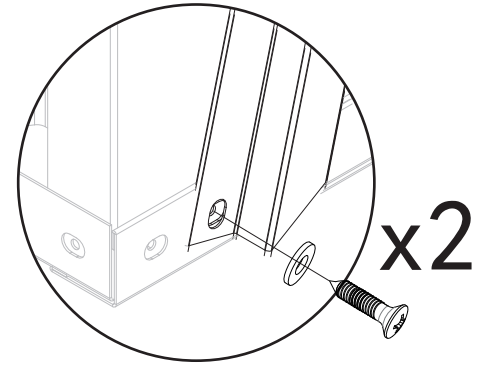
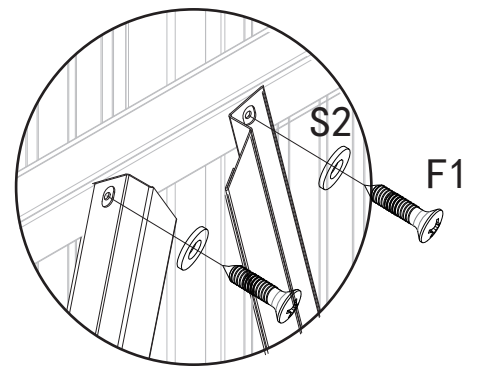
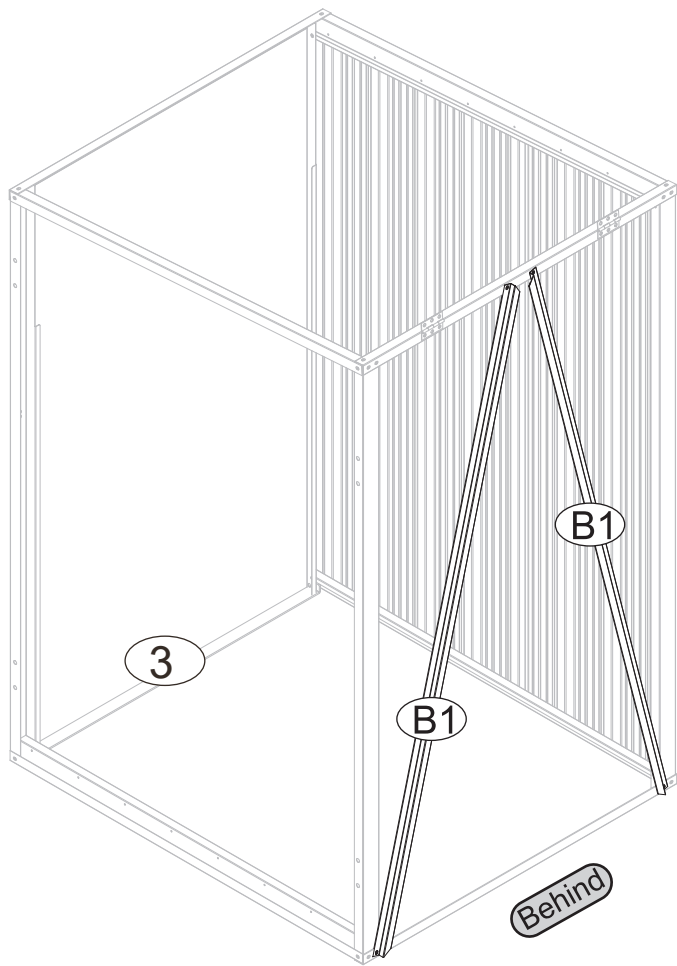

NO.	PART	Qty.
B1		2
F1		4
S2		4

NO.	PART	Qty.
F4		2
F1		20
S2		12

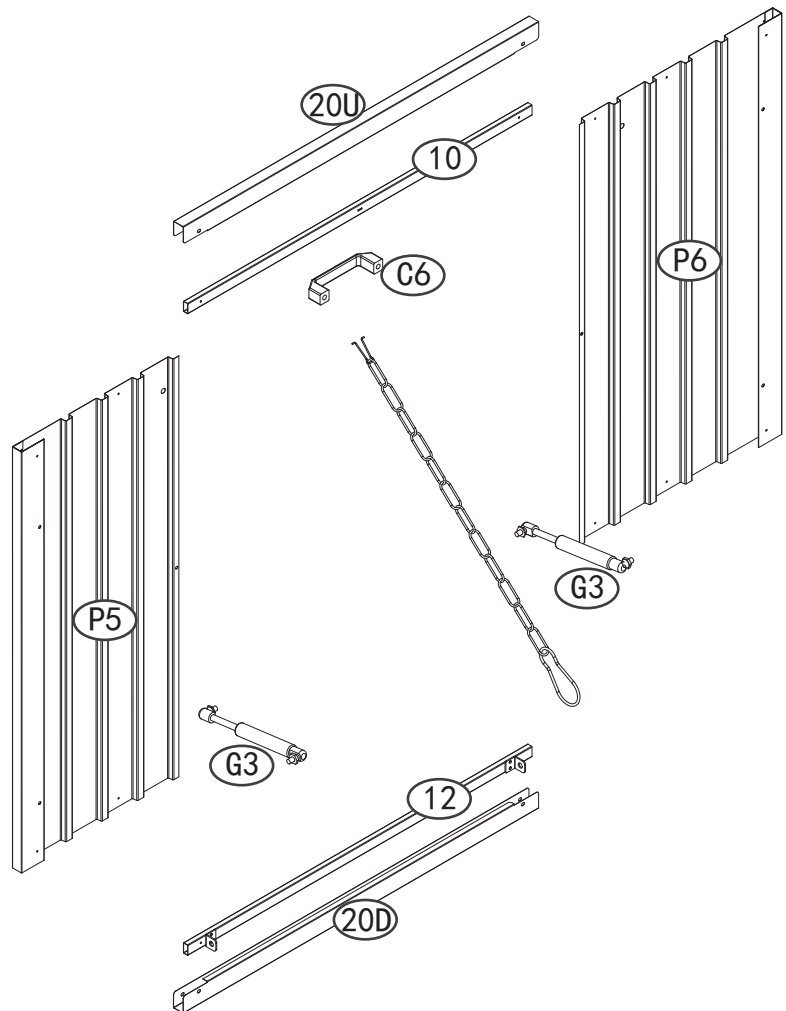

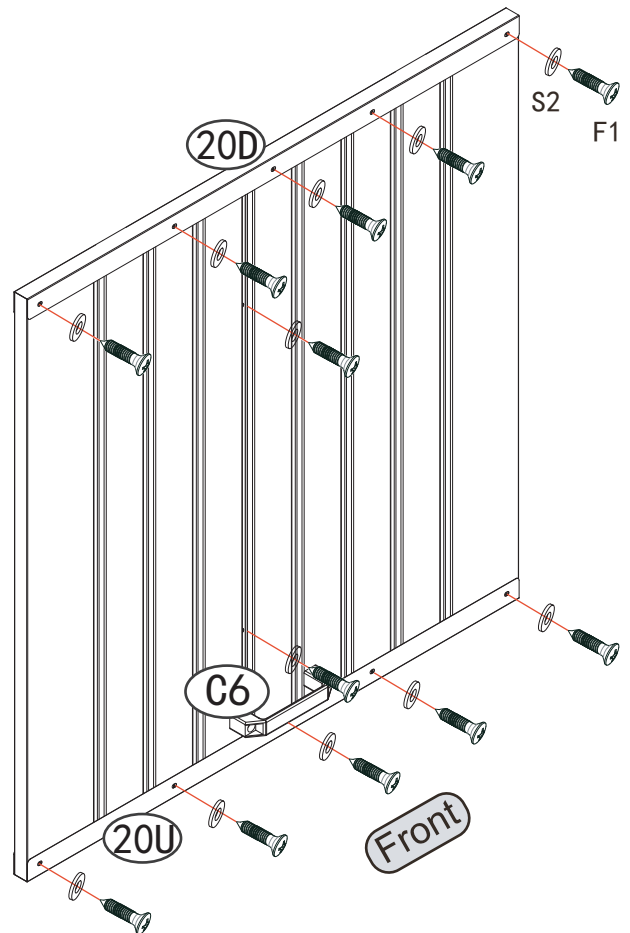
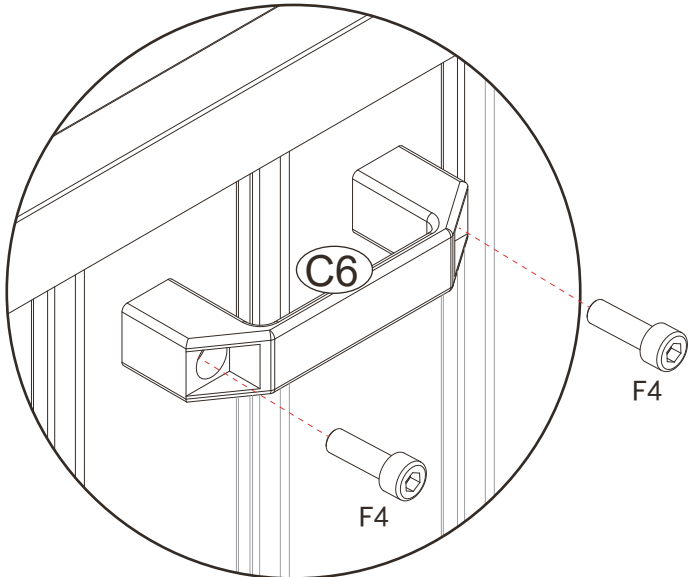
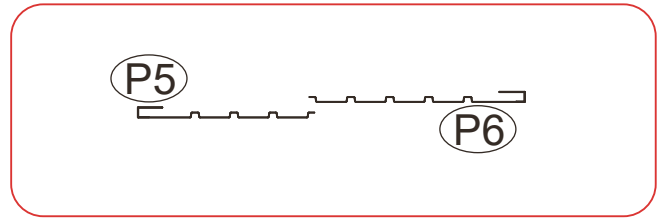
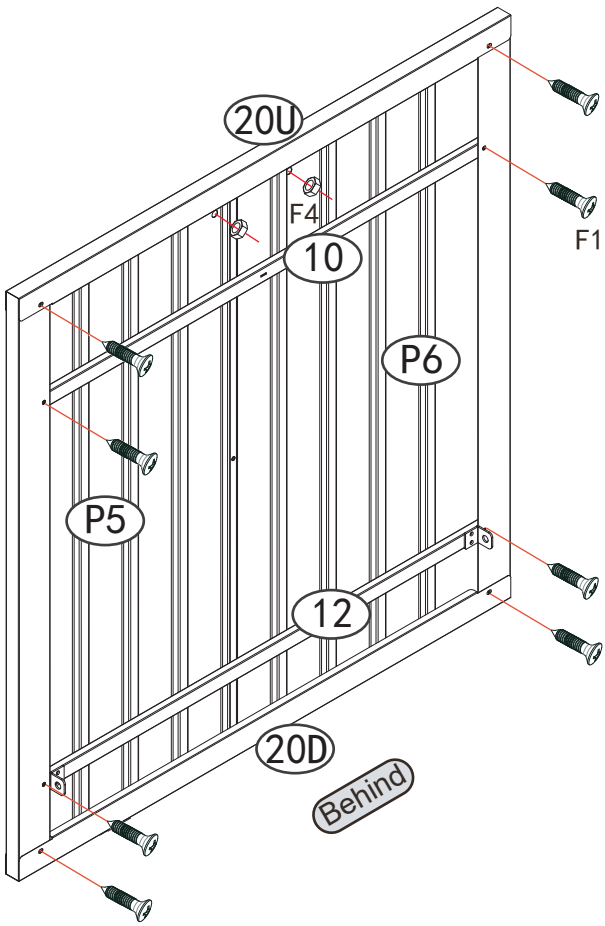

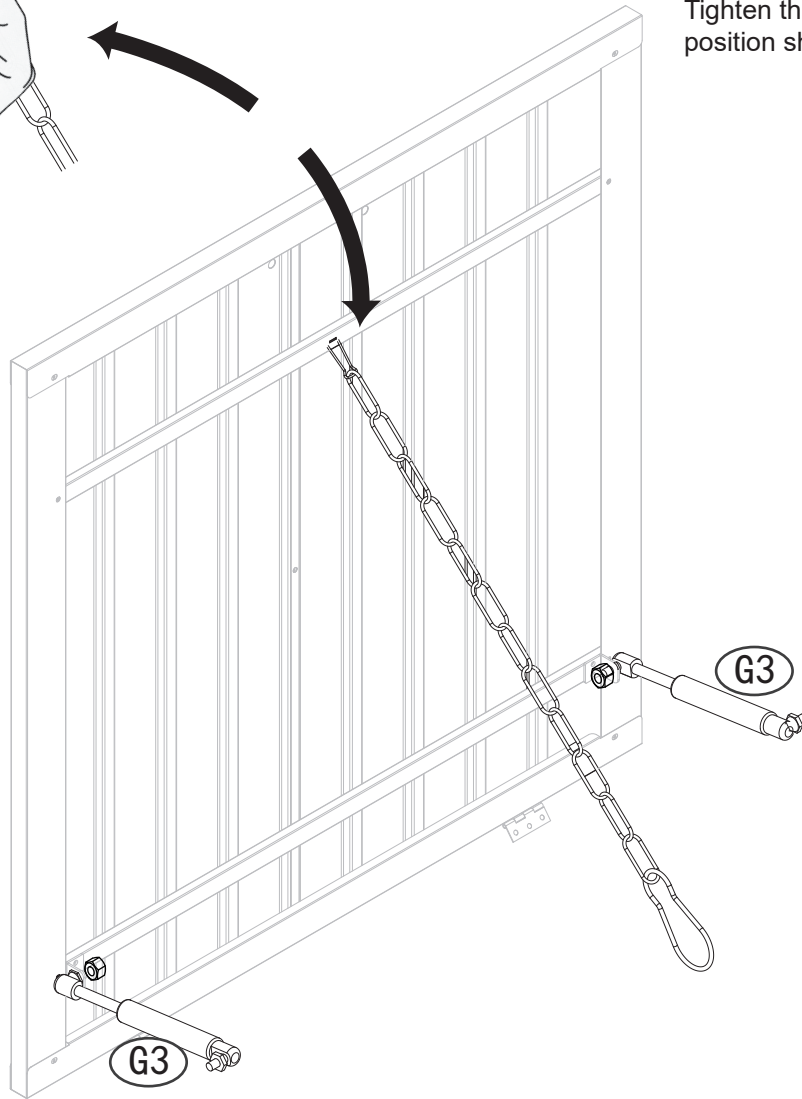
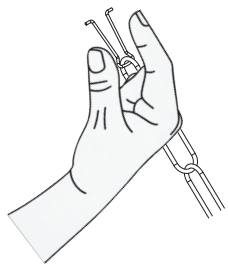

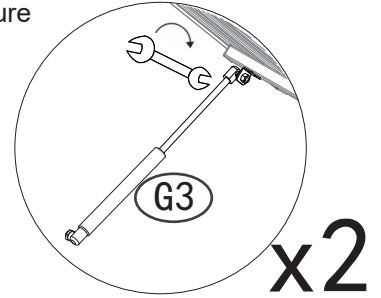

Tighten the bolts with a wrench according to the position shown in the figure



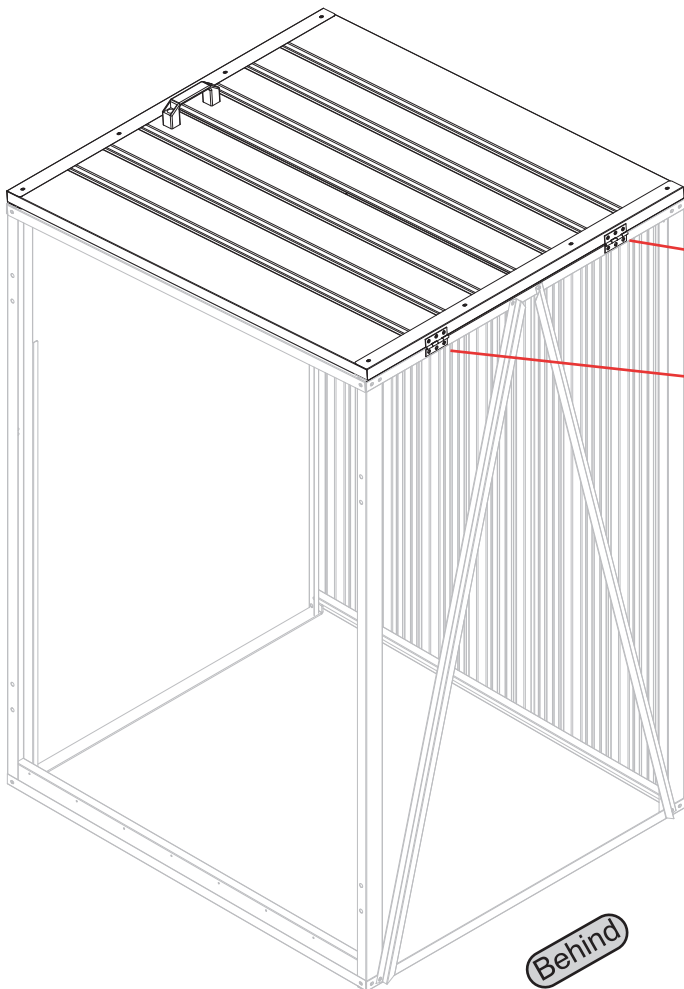

x2

NO.	PART	Qty.
G3		2
M8		2
		1

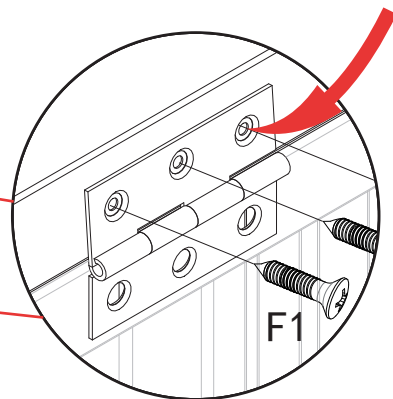

Attention: Install screws on the side with grooves







NO.	PART	Qty.
F1		6

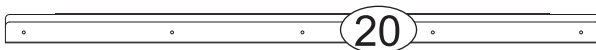
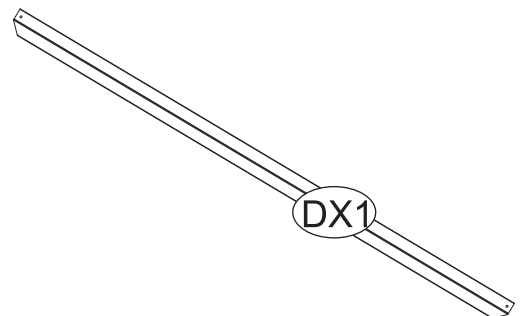
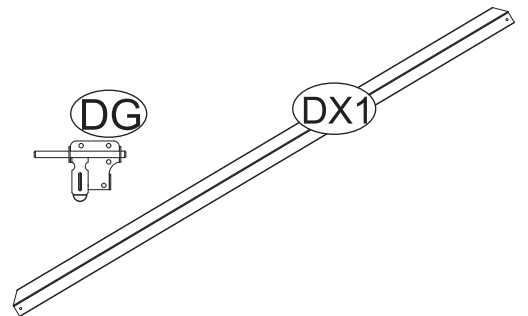
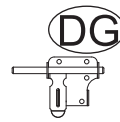
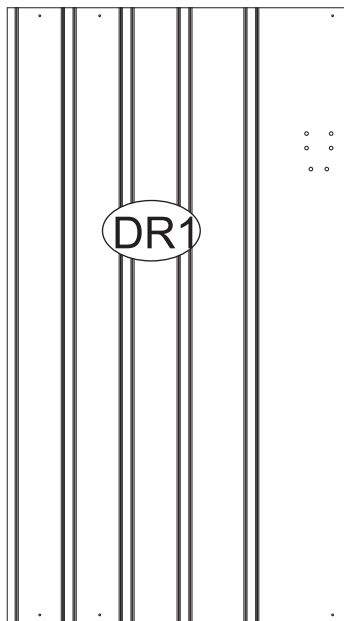
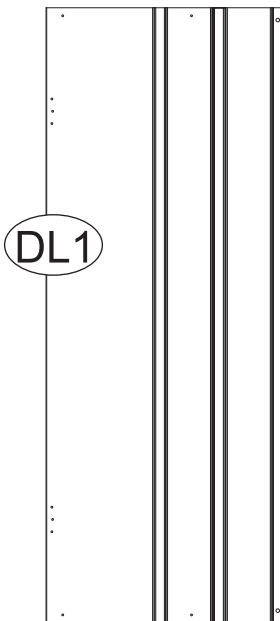
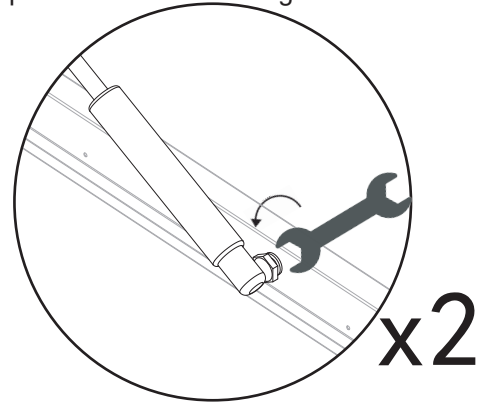

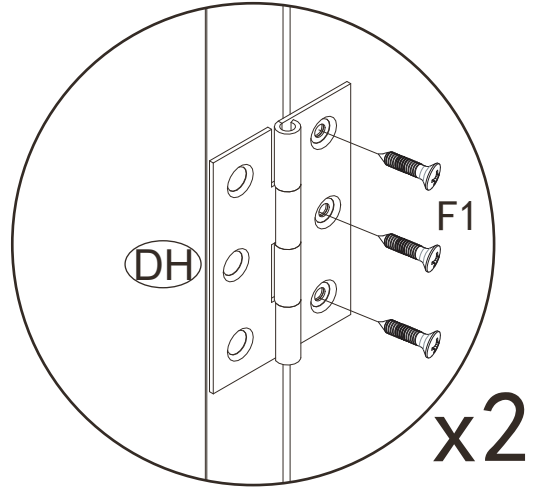
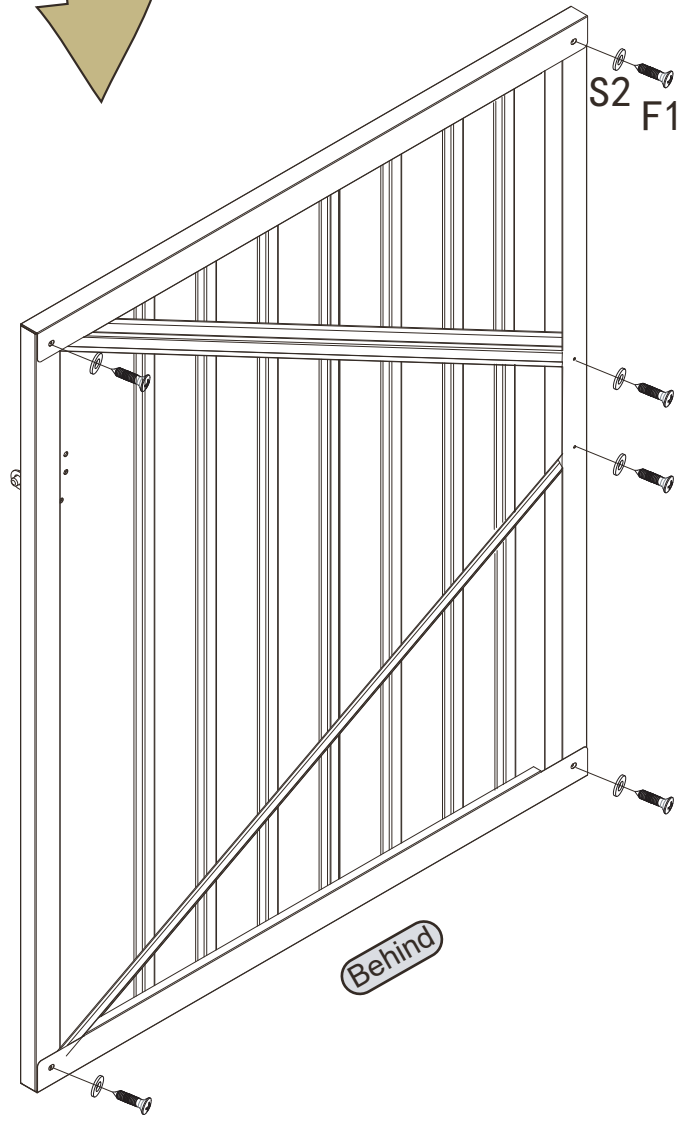
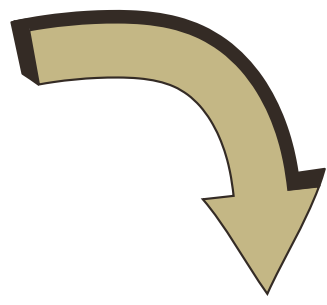
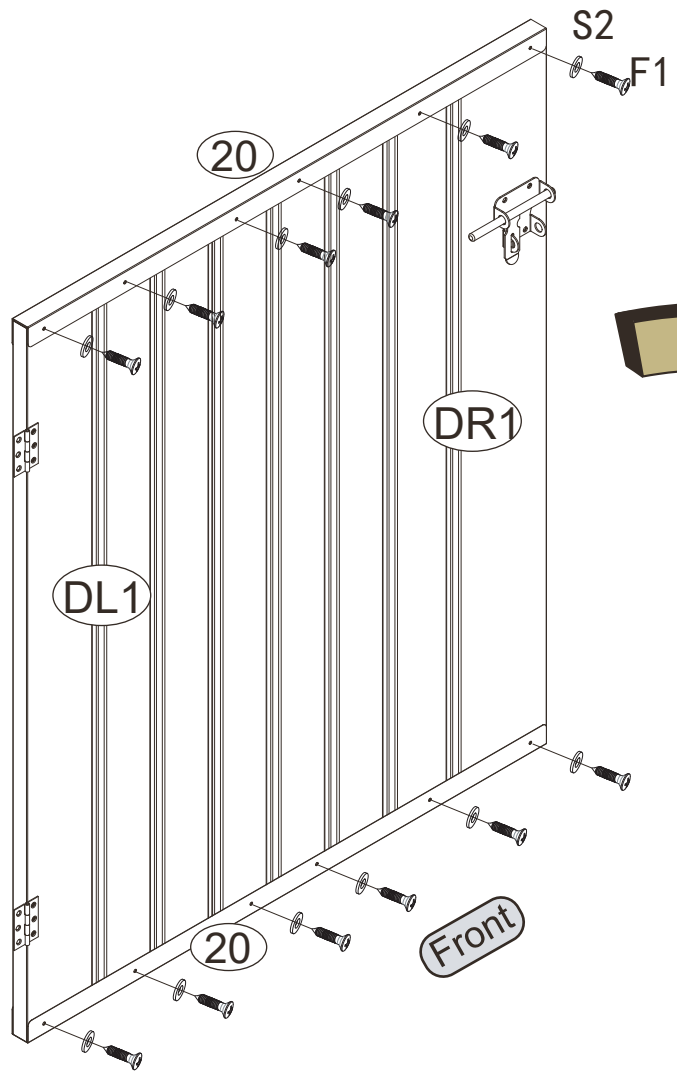
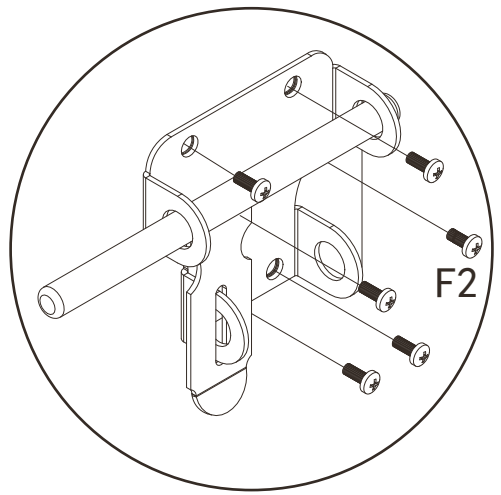
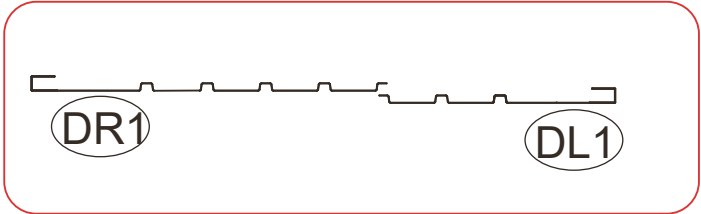
Tighten the bolts with a wrench according to the position shown in the figure







NO.	PART	Qty.
F1		24
F2		6
S2		18

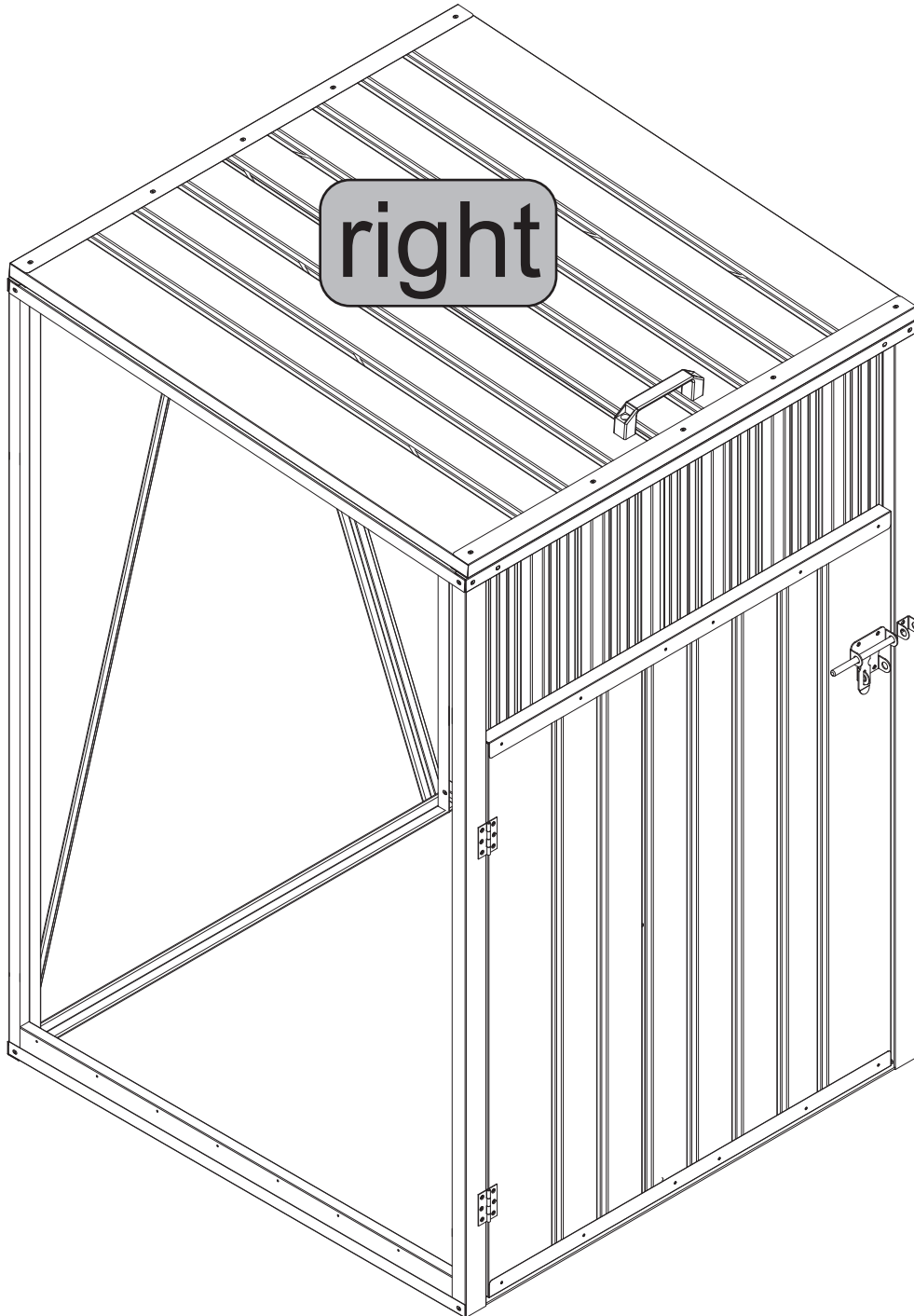
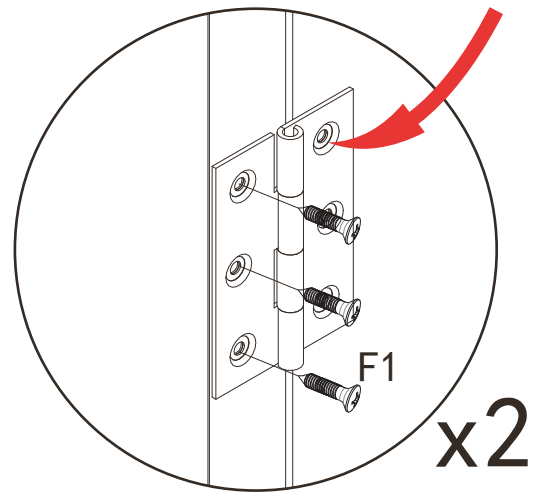
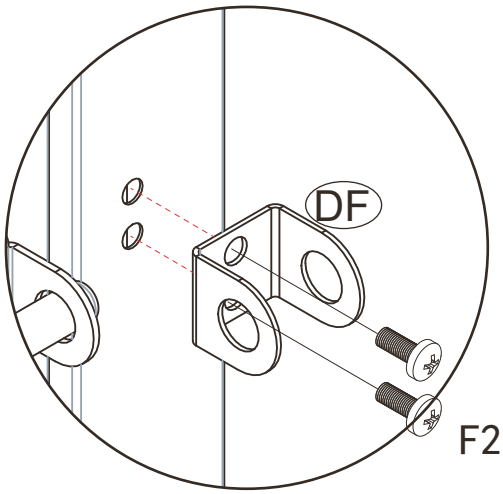





Attention: Install screws on the side with grooves

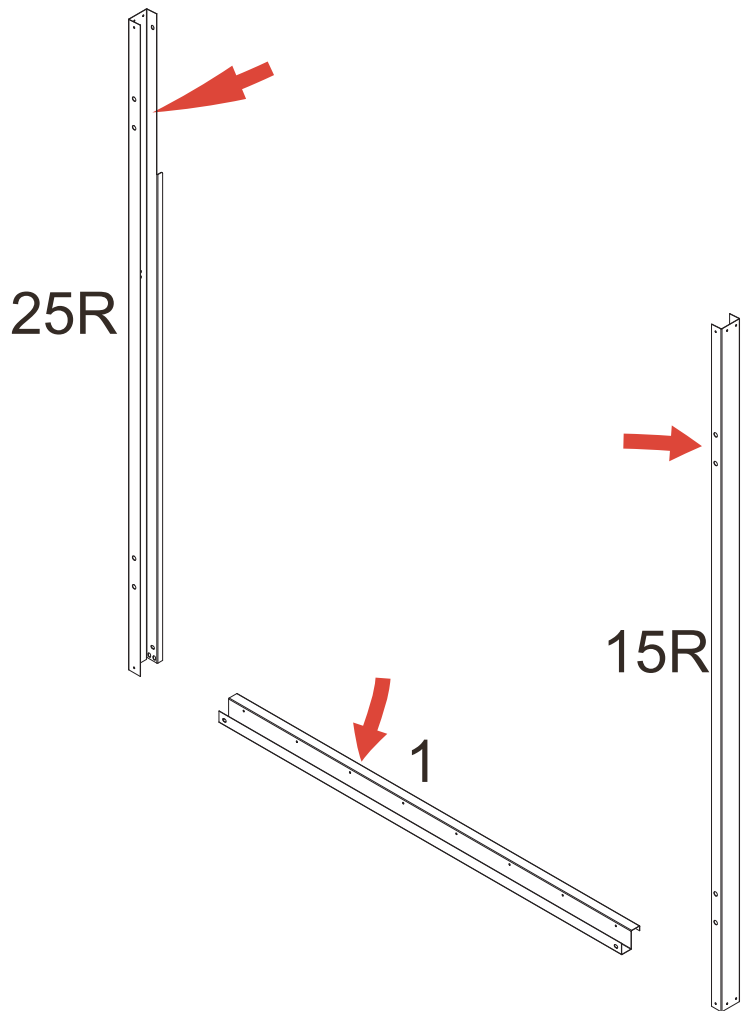
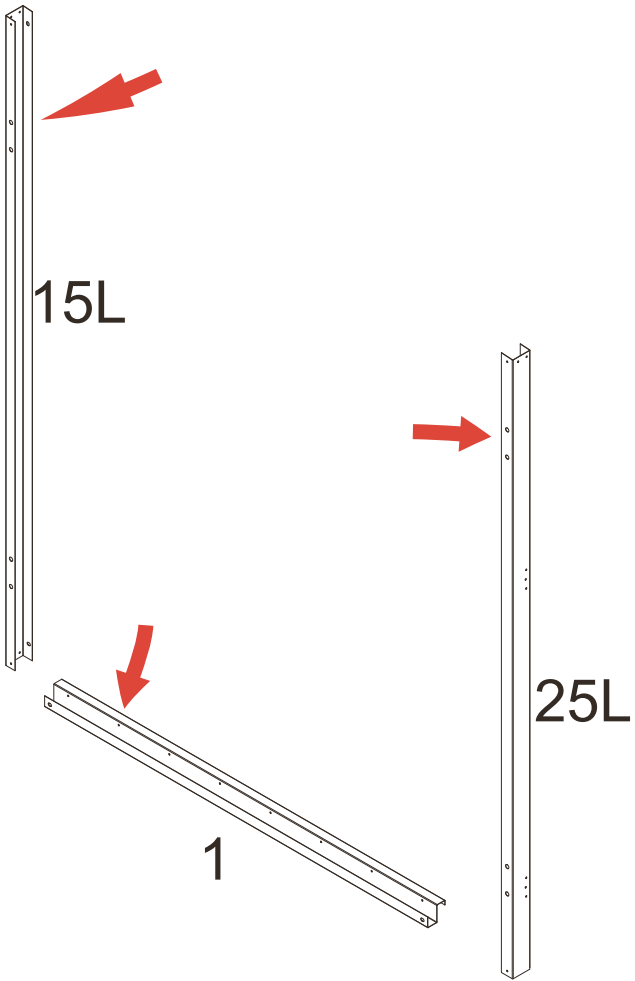

NO.	PART	Qty.
F1		6
F2		2

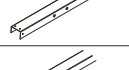
Place as shown in the picture



NO.	PART	Qty.
1		2
15L		1
15R		1
25L		1
25R		1
F1		8
S2		8

This step can find a platform to lay the product flat for easier installation

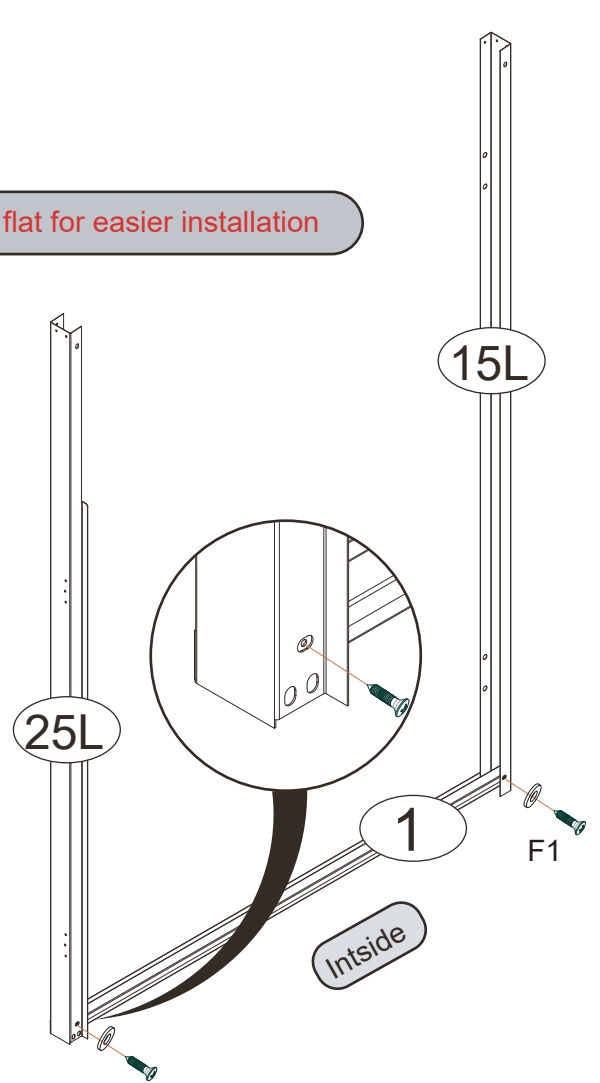
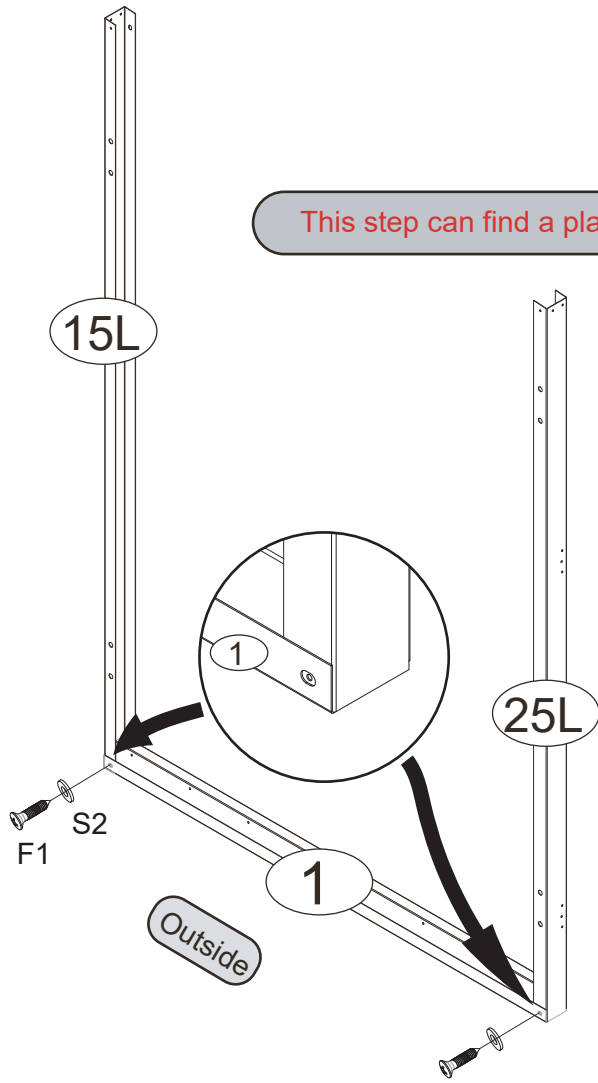

This step can find a platform to lay the product flat for easier installation

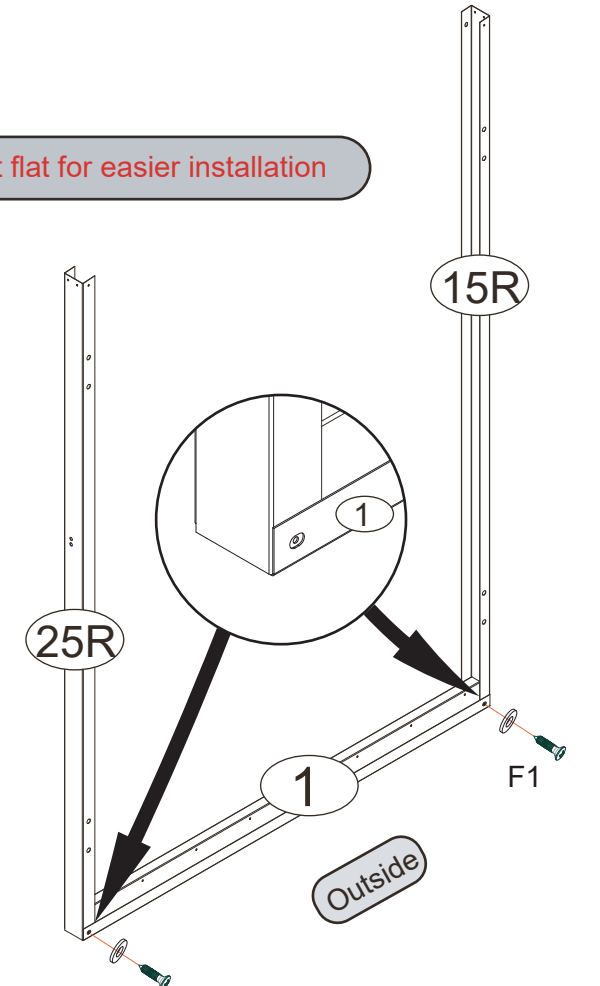
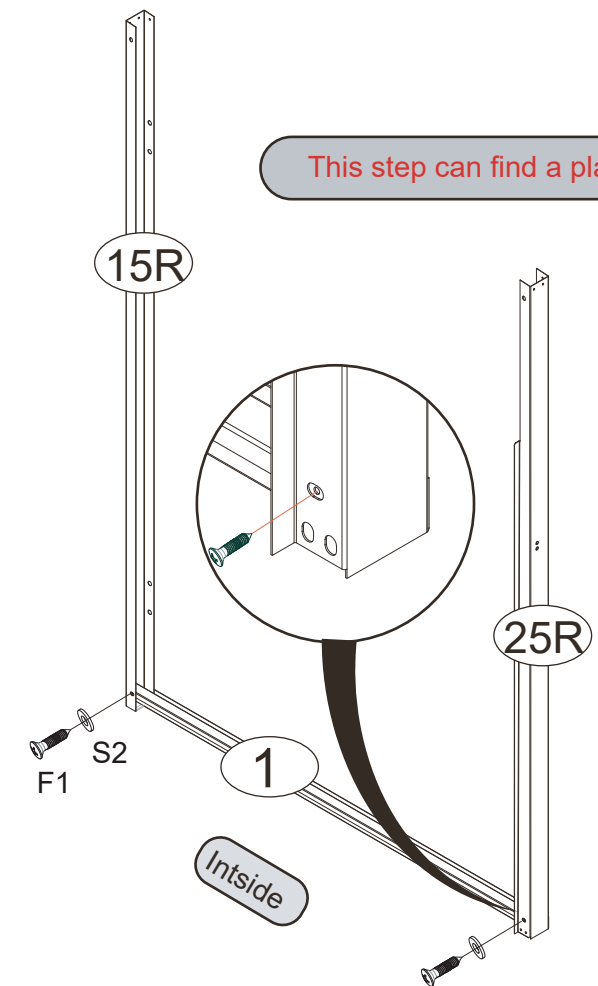

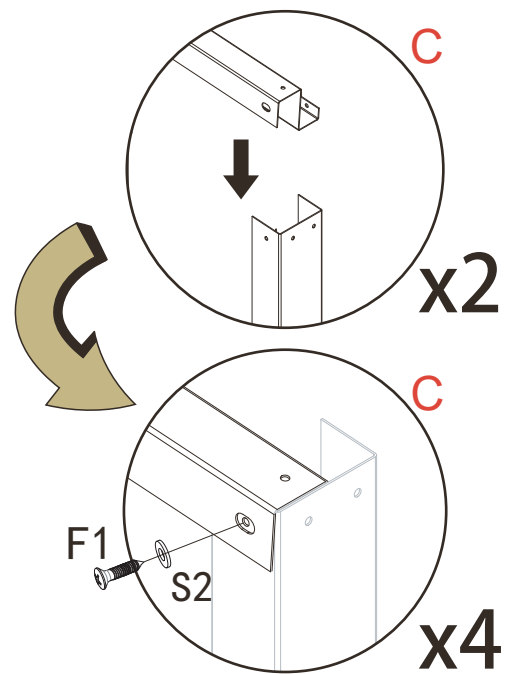
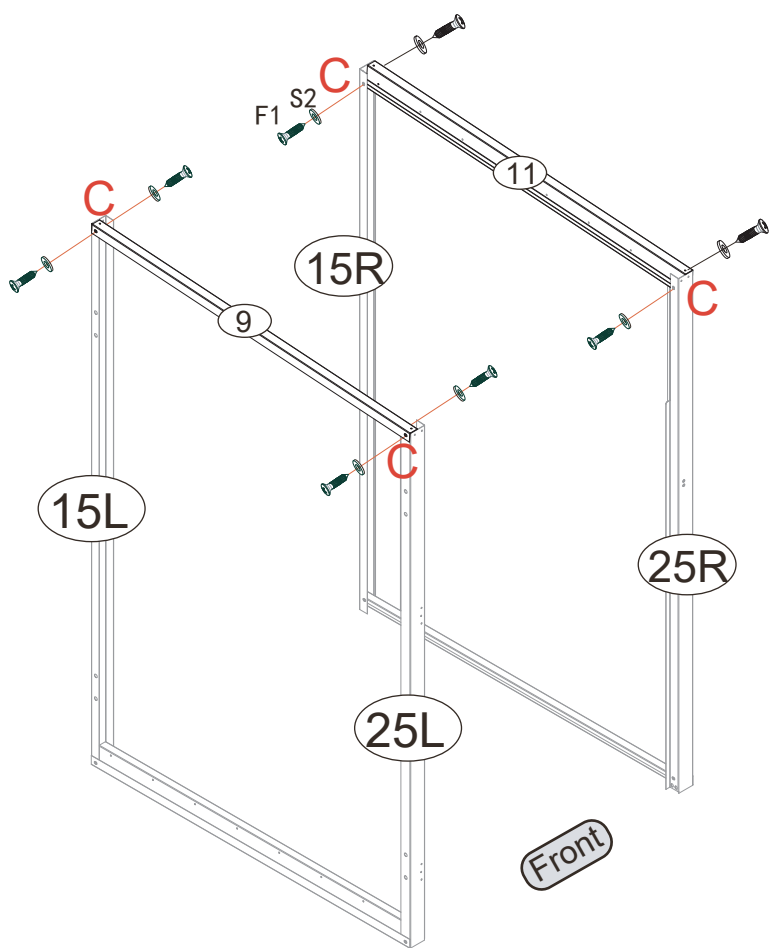

NO.	PART	Qty.
9		1
11		1
F1		8
S2		8

This step can find a platform to lay the product flat for easier installation

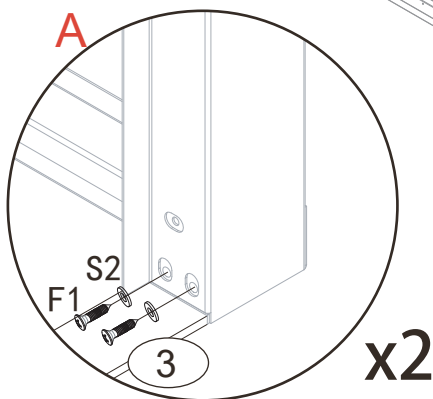
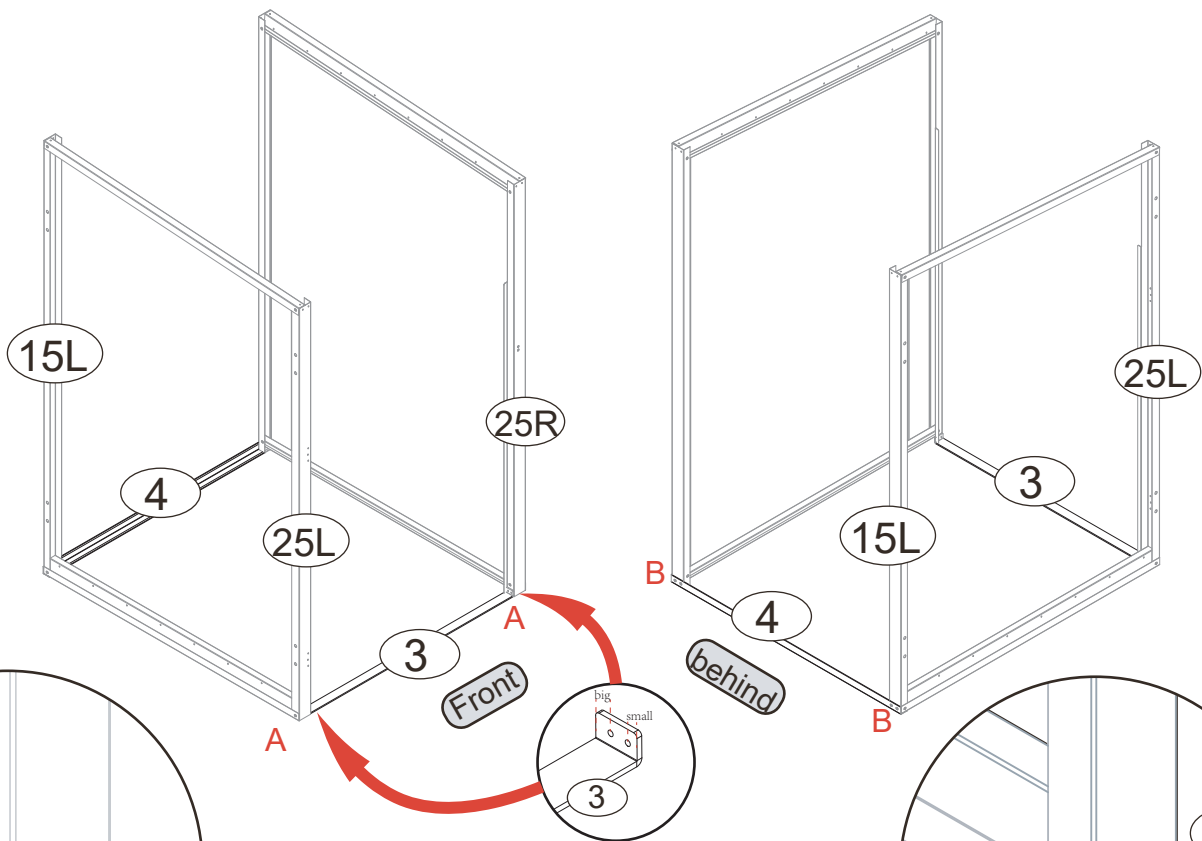

NO.	PART	Qty.
3		1
4		1
F1		6
S2		6

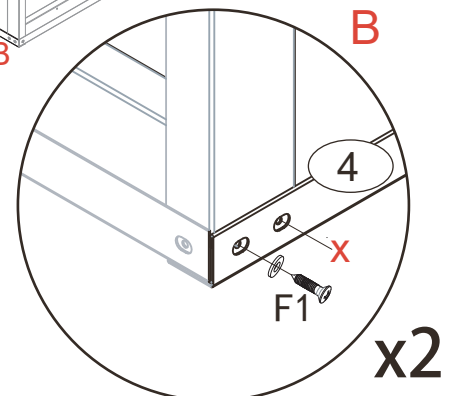

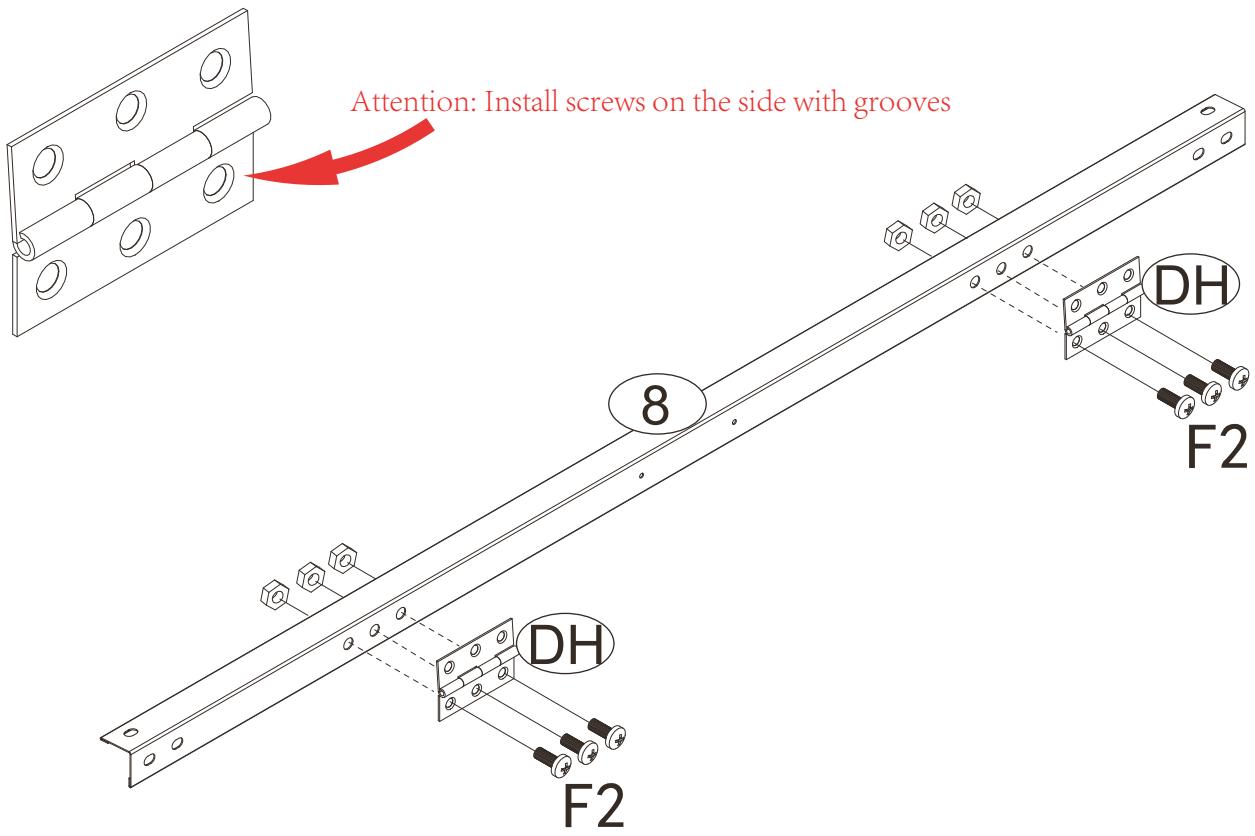

NO.	PART	Qty.
F2		6

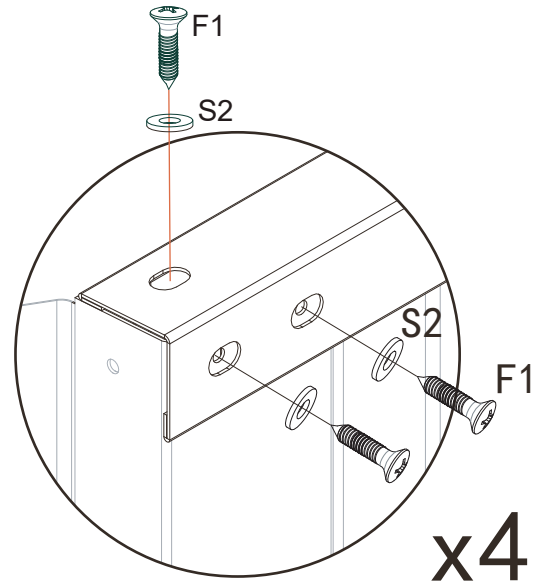
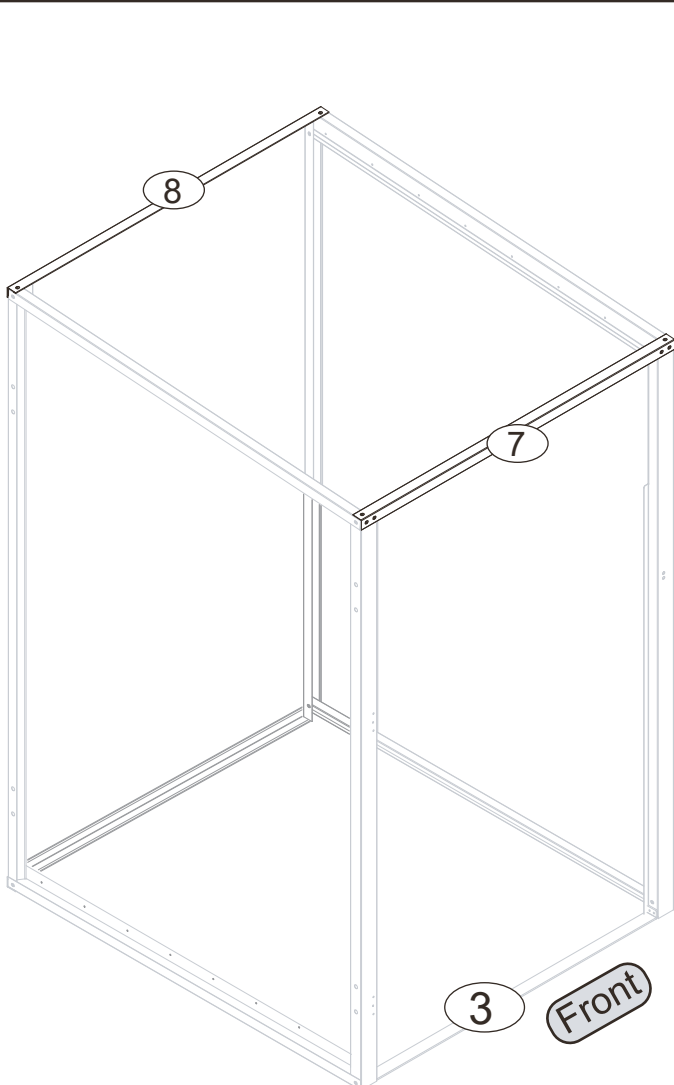

NO.	PART	Qty.
7		1
8		1
F1		12
S2		12

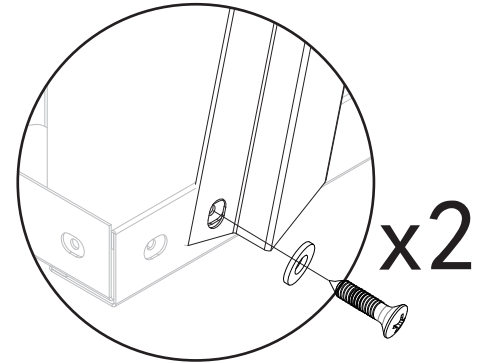
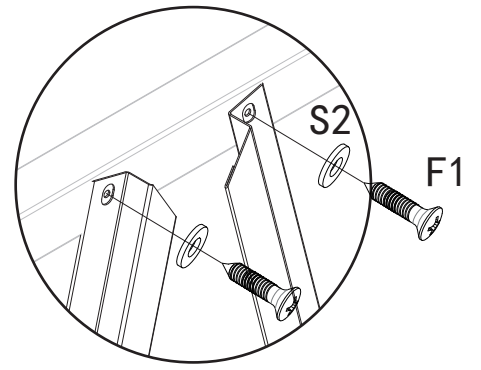
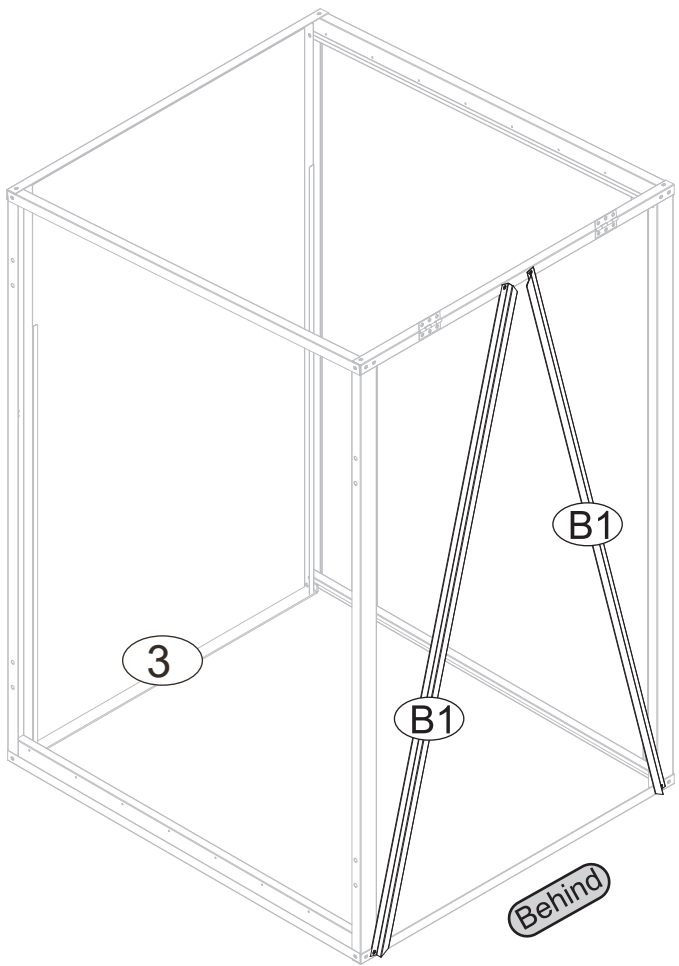

NO.	PART	Qty.
B1		2
F1		4
S2		4

NO.	PART	Qty.
F4		2
F1		20
S2		12

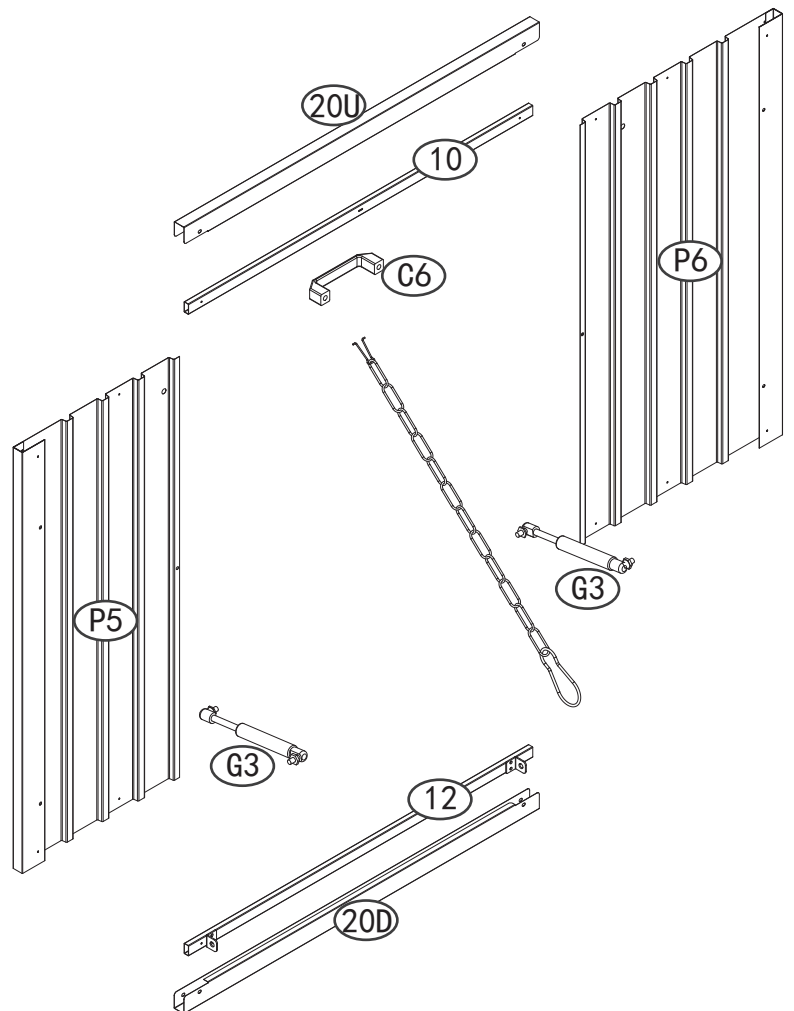

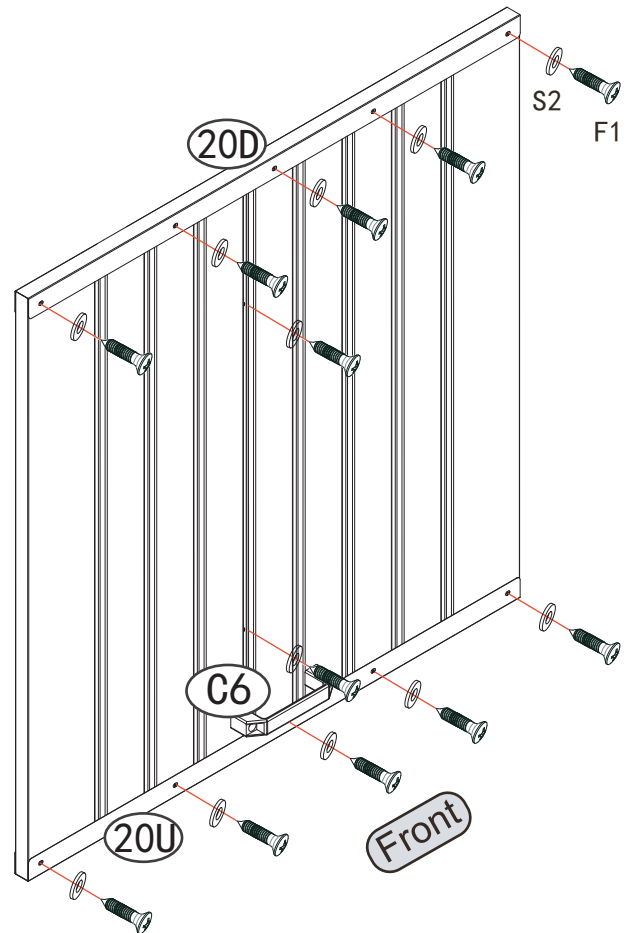
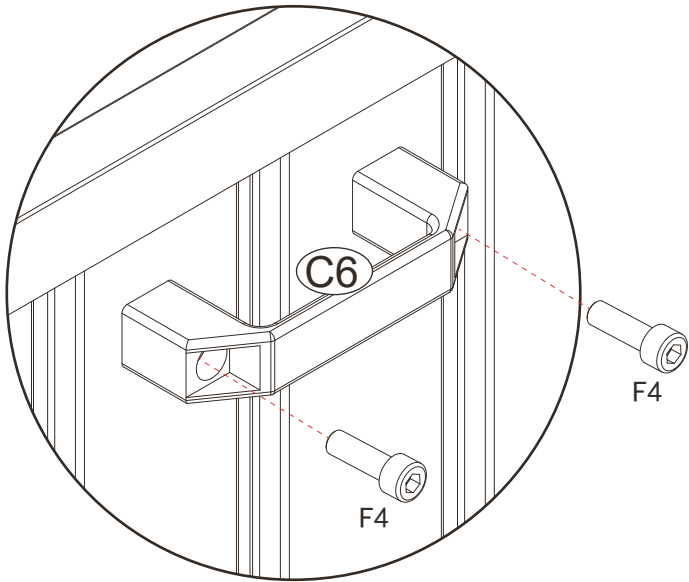
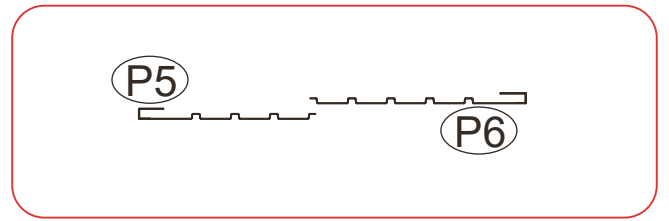
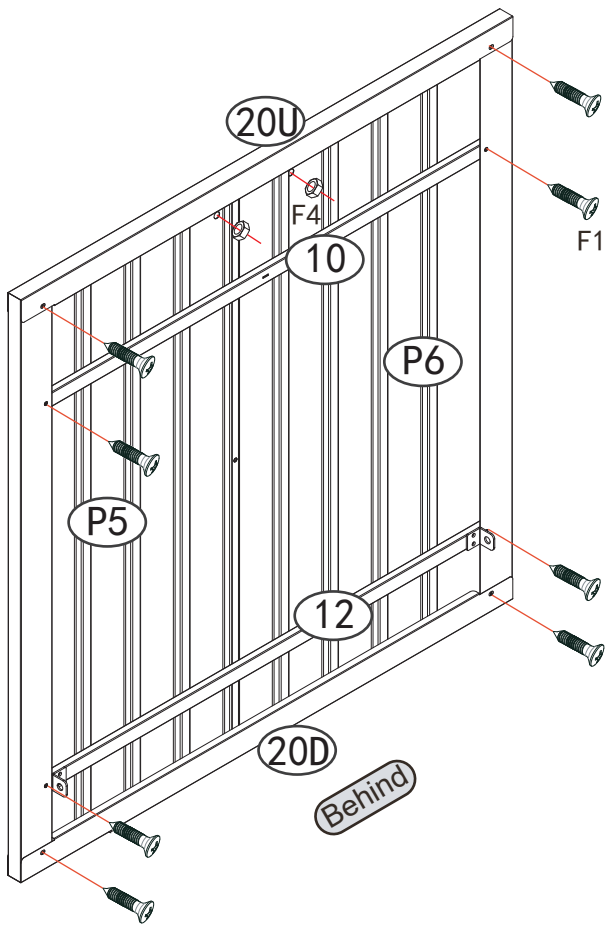

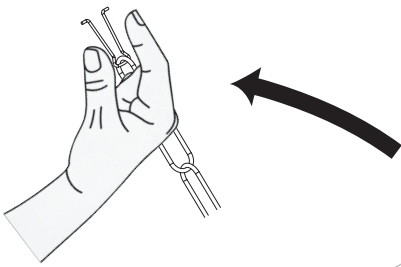

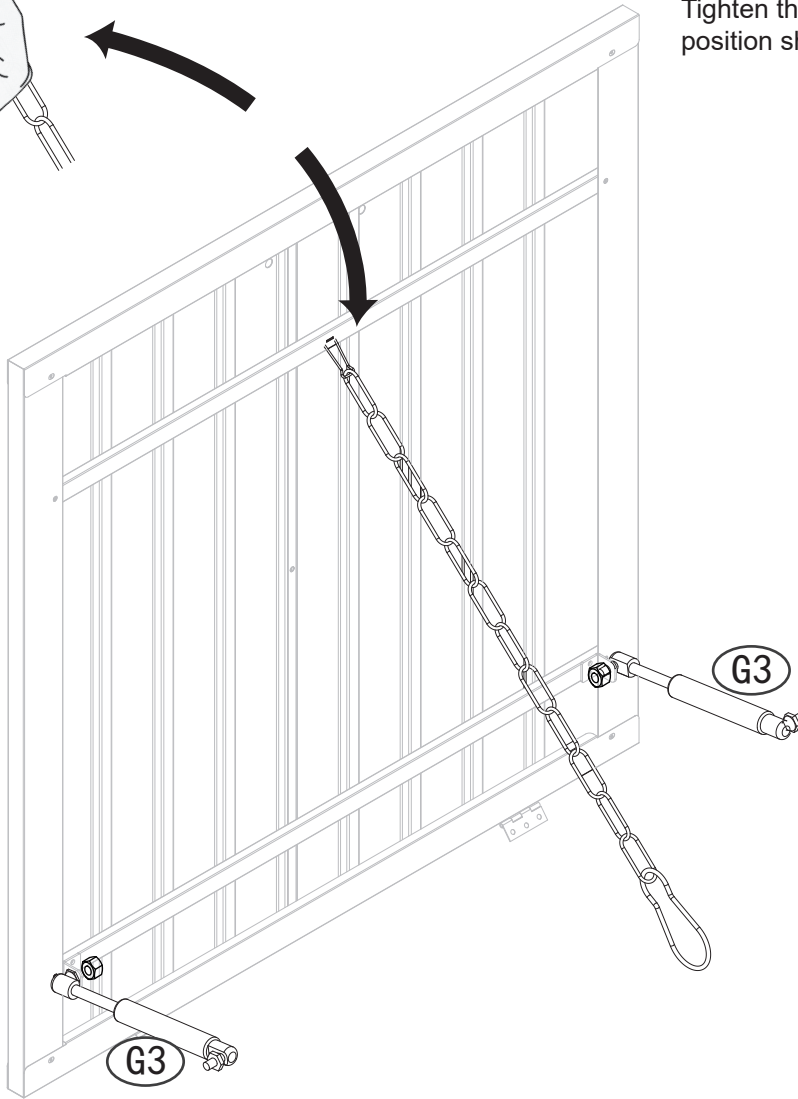
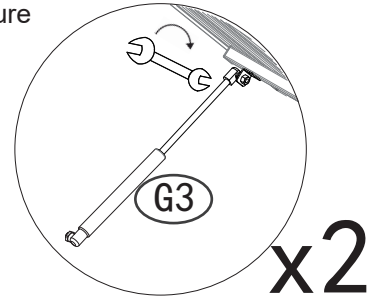

Tighten the bolts with a wrench according to the position shown in the figure



NO.	PART	Qty.
G3		2
M8		2
		1

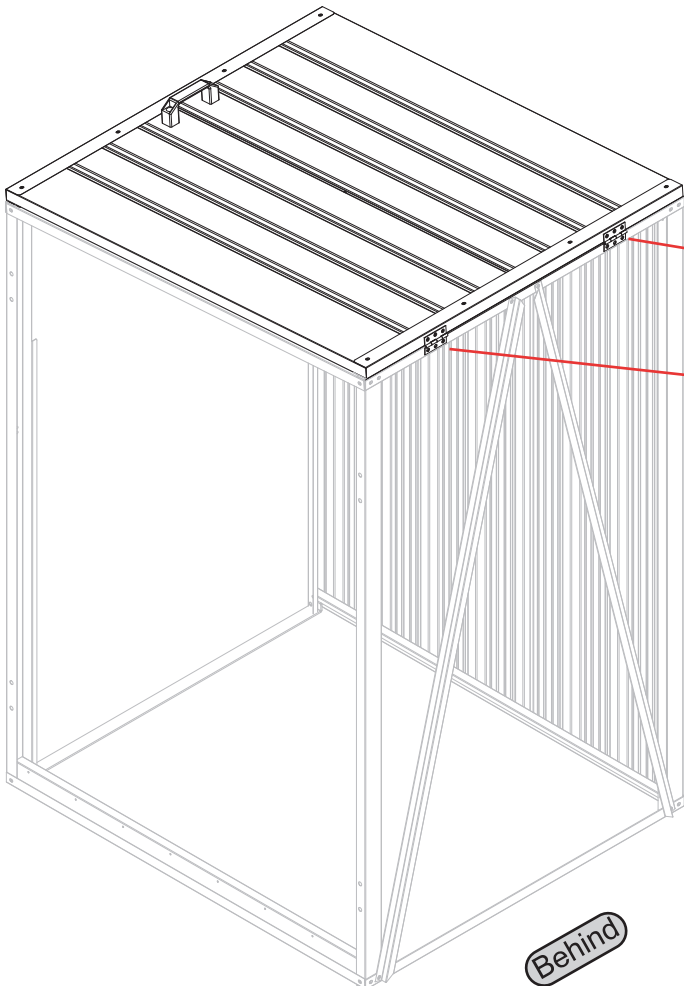

Attention: Install screws on the side with grooves

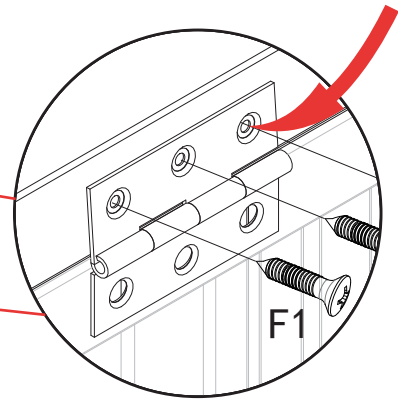





NO.	PART	Qty.
F1		6

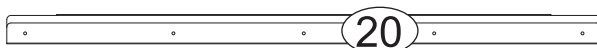
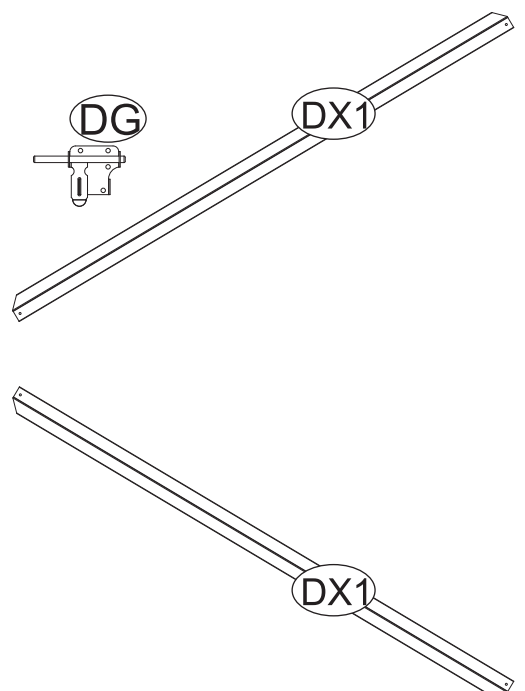
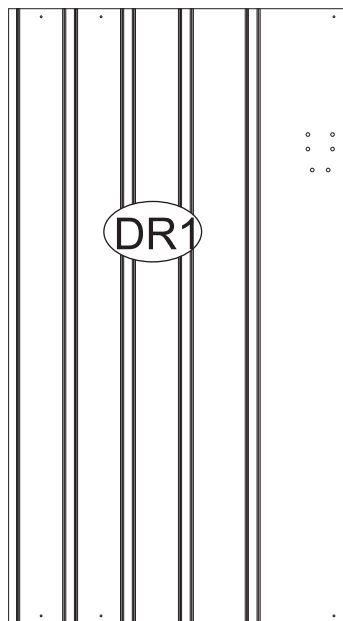
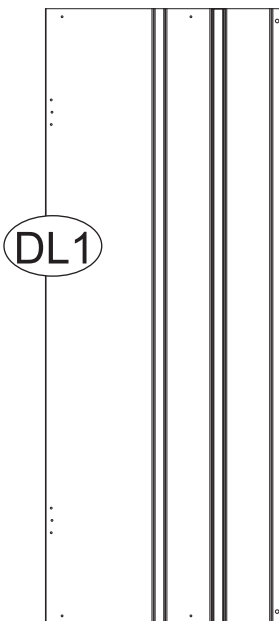
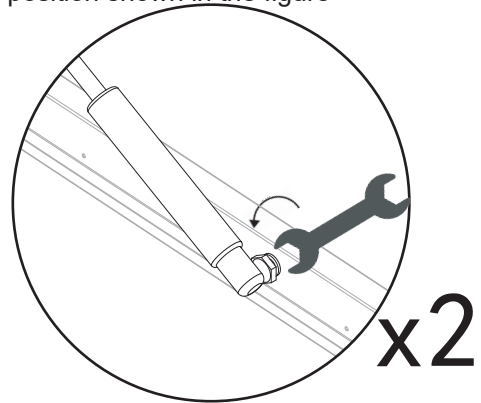

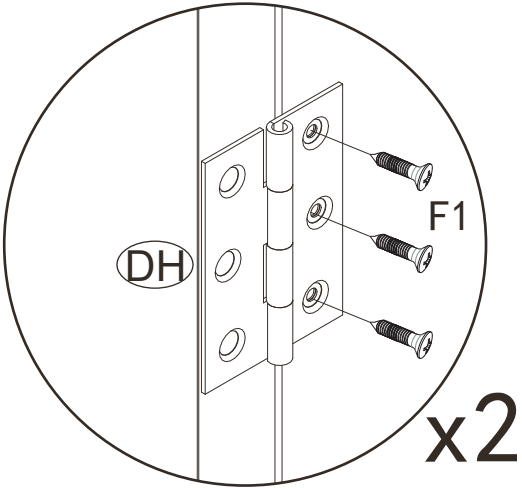
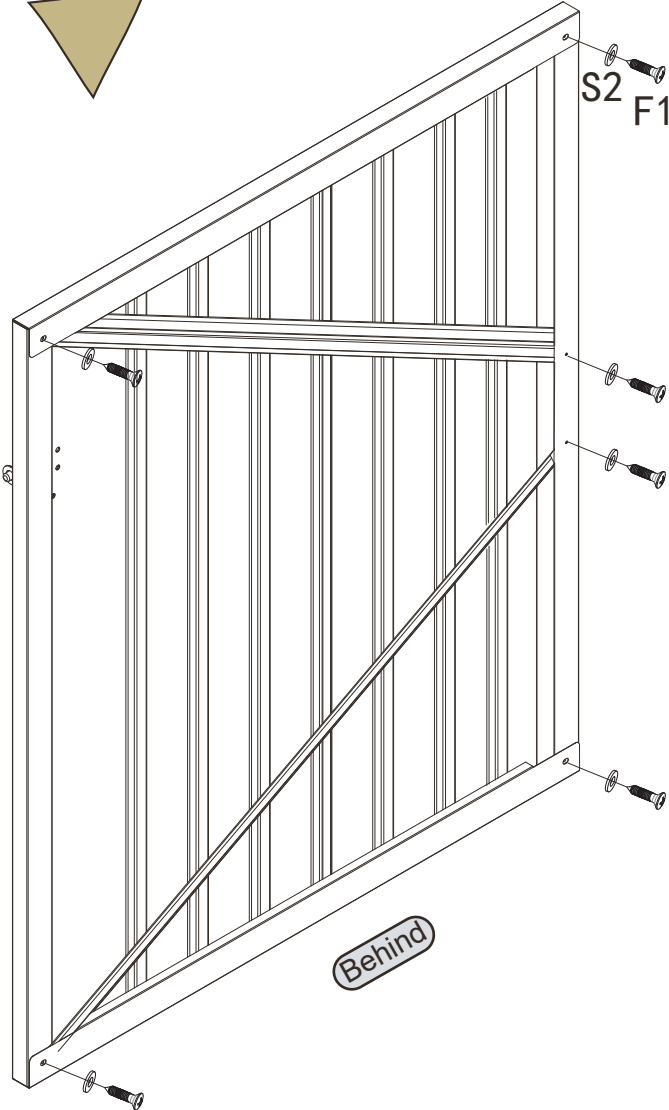
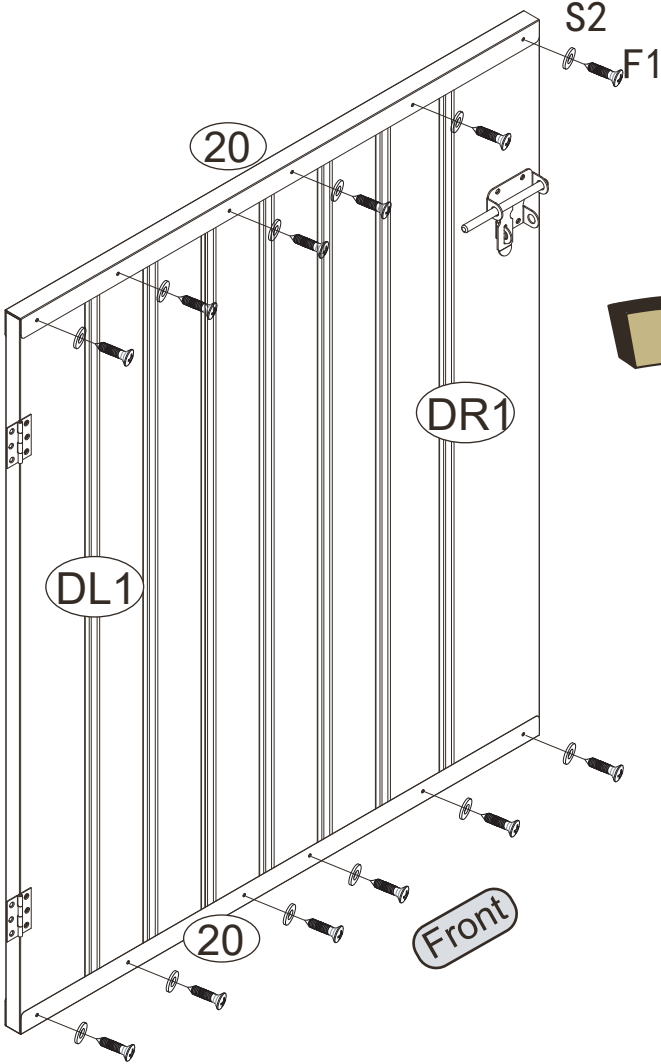
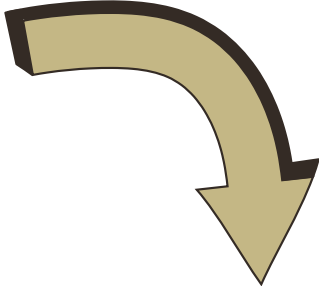
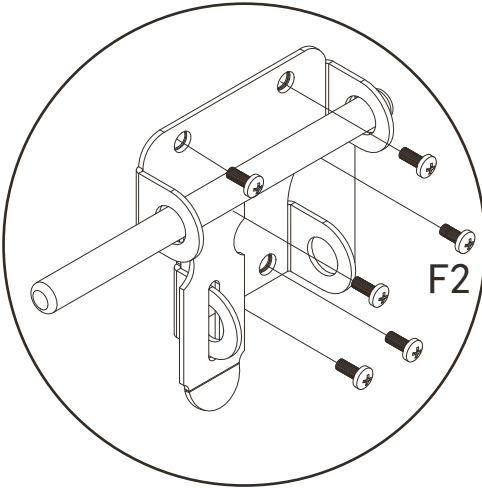
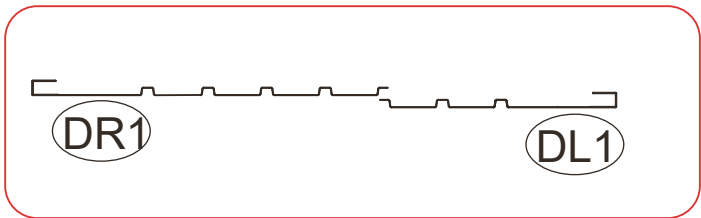
Tighten the bolts with a wrench according to the position shown in the figure







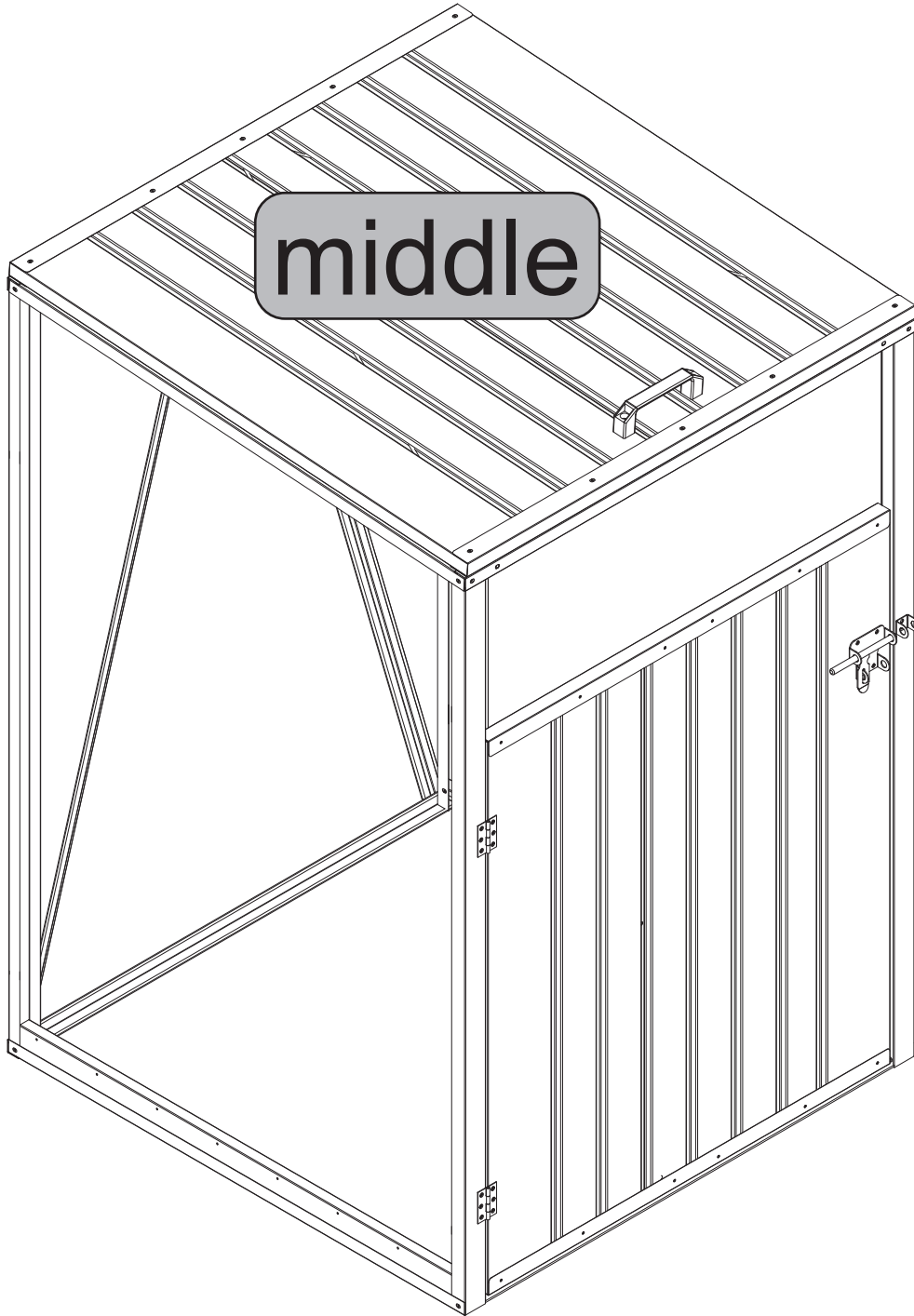
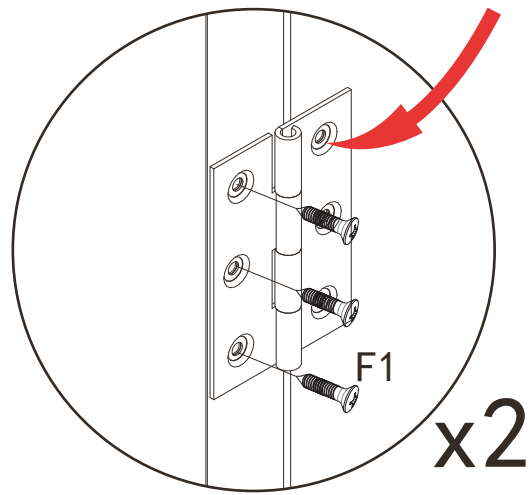
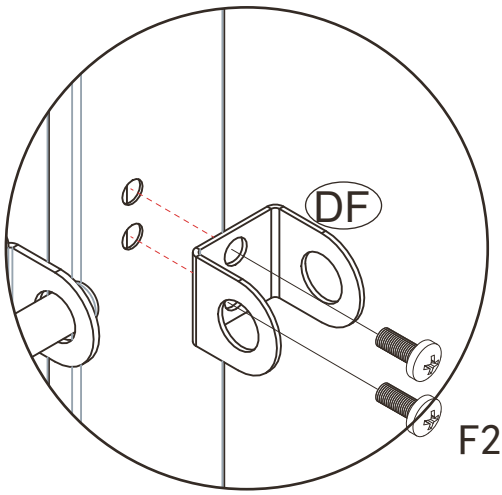

NO.	PART	Qty.
F1		24
F2		6
S2		18

Attention: Install screws on the side with grooves

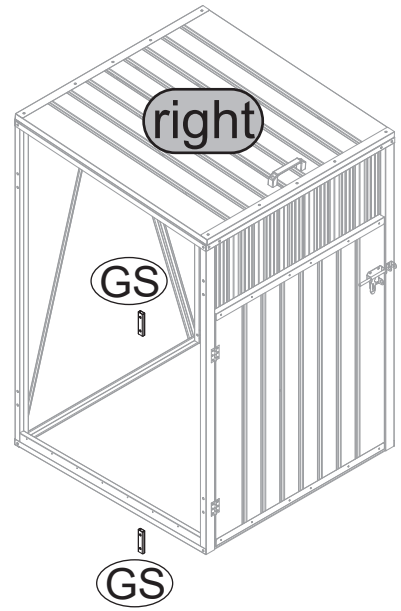
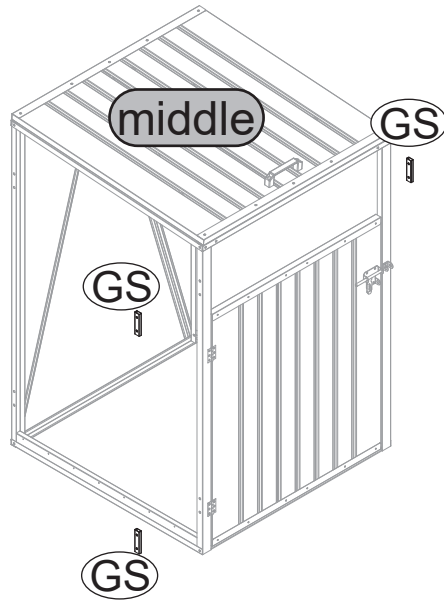
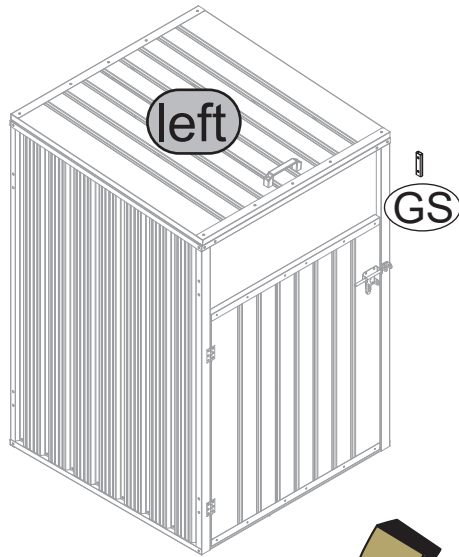
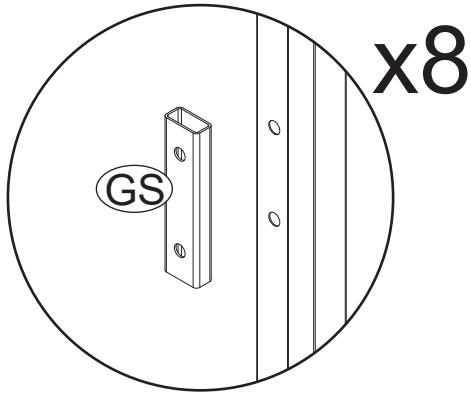

NO.	PART	Qty.
F1		6
F2		2



NO.	PART	Qty.
GS		8
F3		16

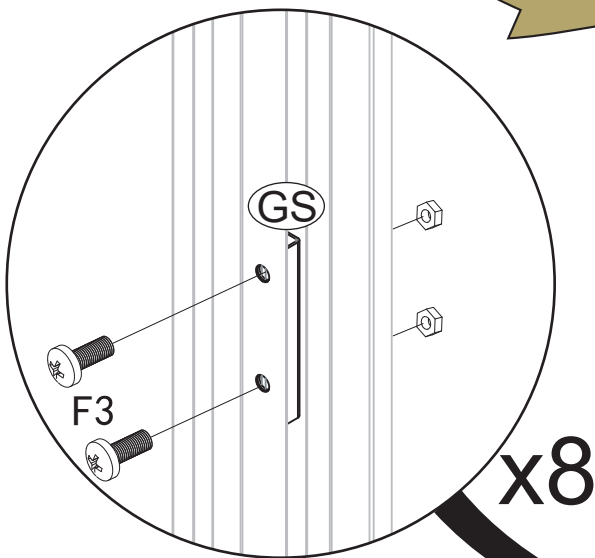
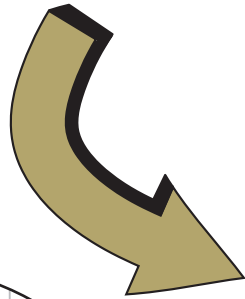

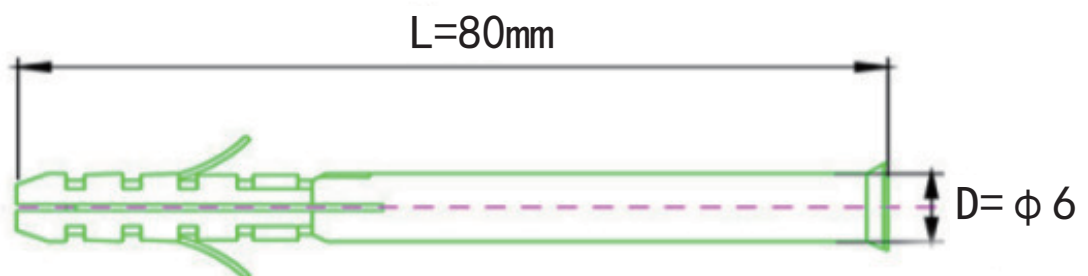
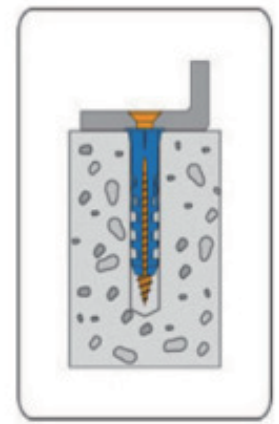
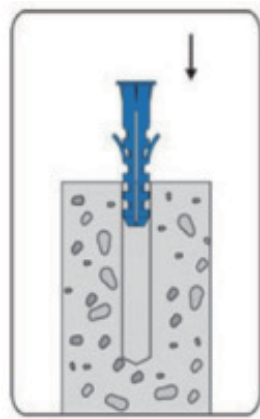
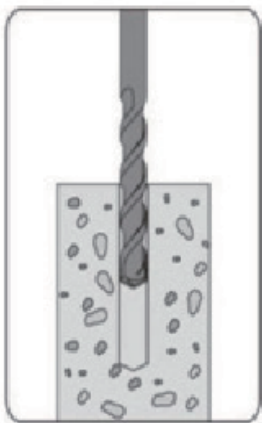
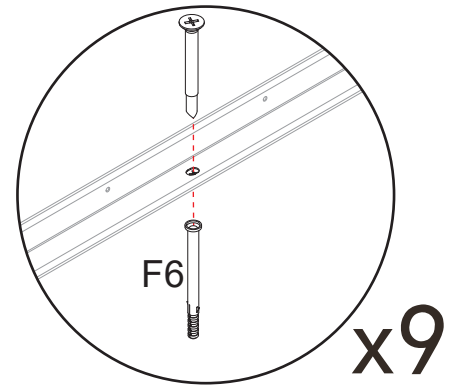
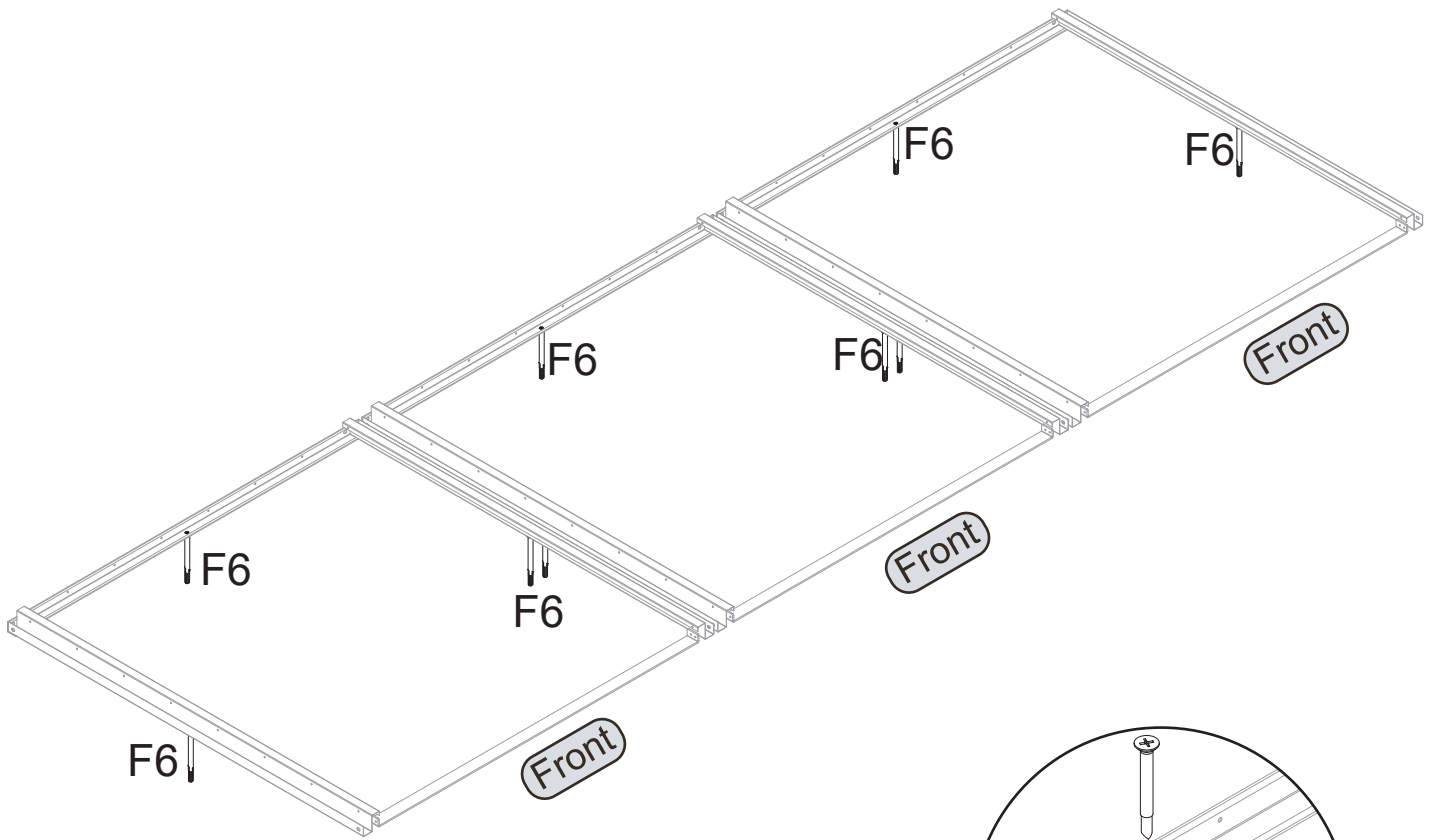

The F6 ground nail will be hidden in a later installation step

