

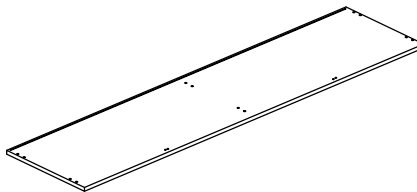

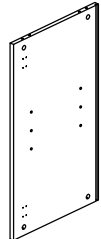

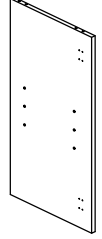

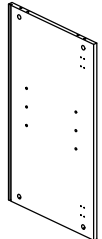



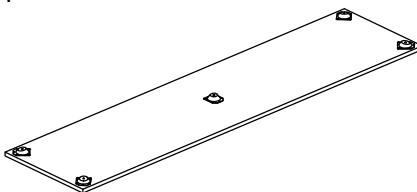
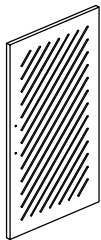
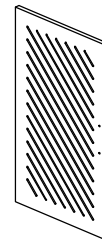
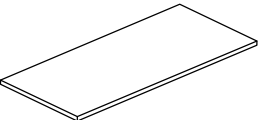
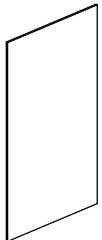

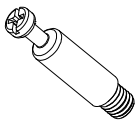
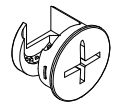
# ASSEMBLY INSTRUCTION

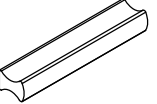
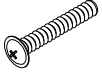
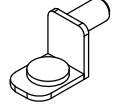
A  1 pc	B  1 pc	C  1 pc	D  1 pc	E  3 pcs
F  1 pc	G  2 pcs	H  2 pcs	I  2 pcs	J  4 pcs
K  1 pc	L  4 pcs	1  12 pcs	2  12 pcs	3  12 pcs
4  4 pcs	5  8 pcs	6  8 pcs	7  4 pcs	8  8 pcs
9  48 pcs	10  16 pcs	11  16 pcs	12  1 pc	

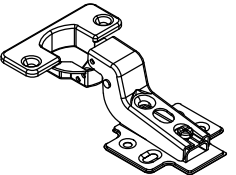
### Step 1

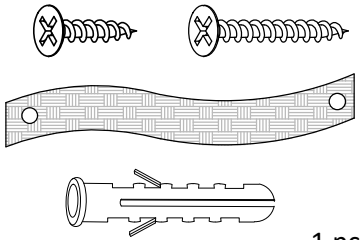
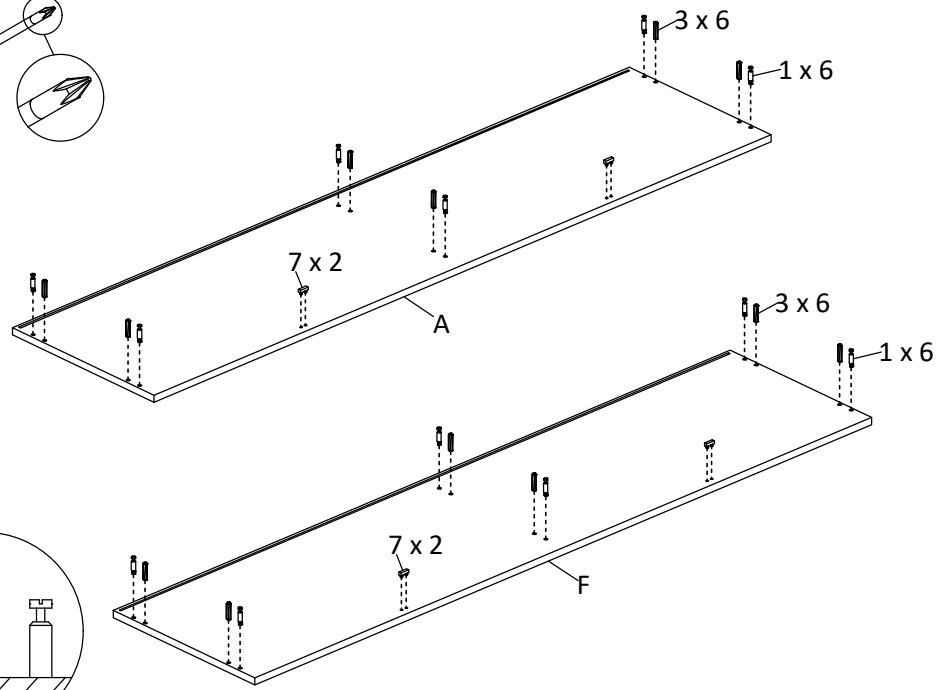
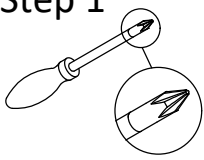

### Step 2

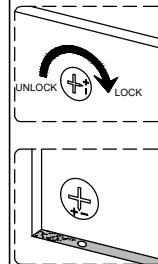
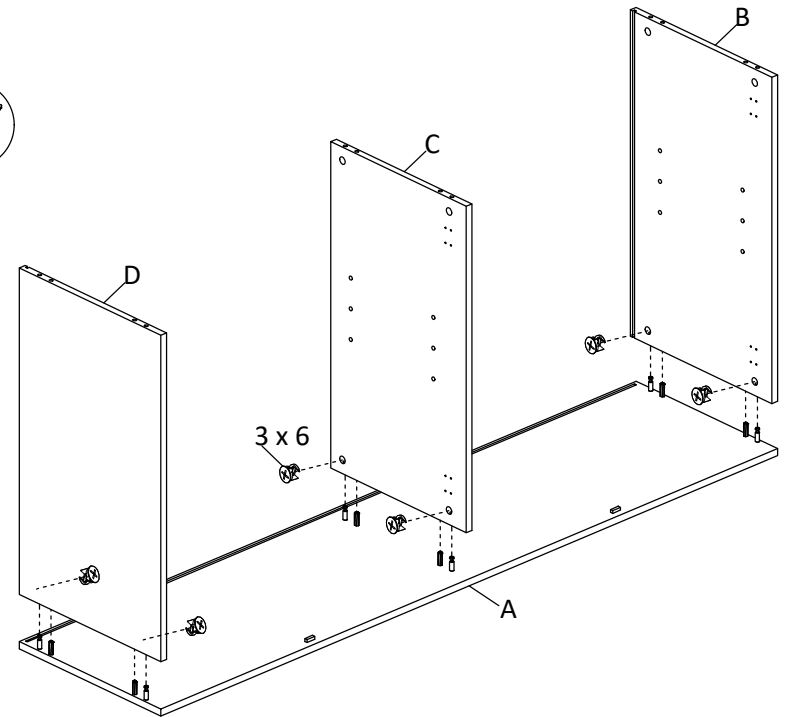
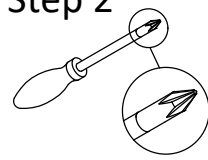

Proper orientation of CAM LOCK

### Step 3

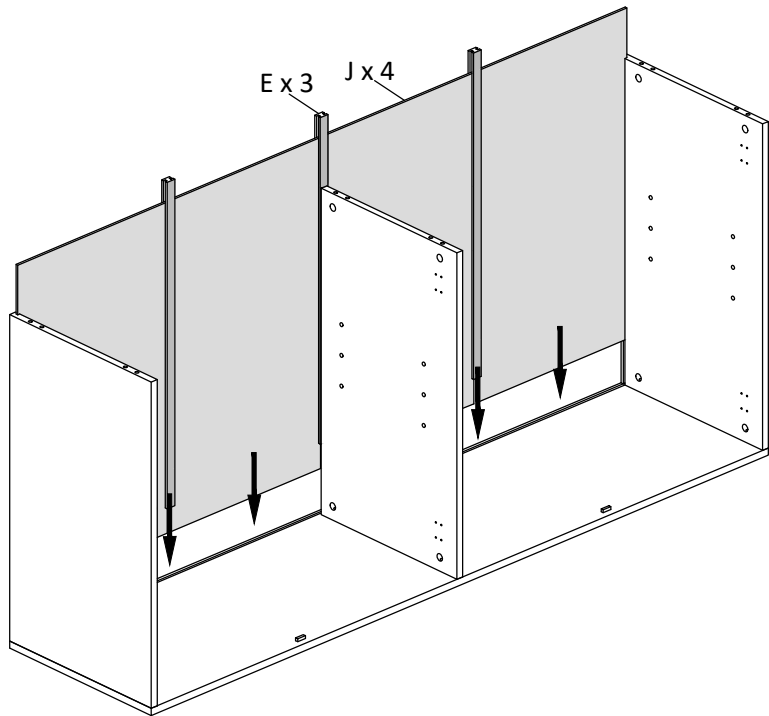

### Step 4

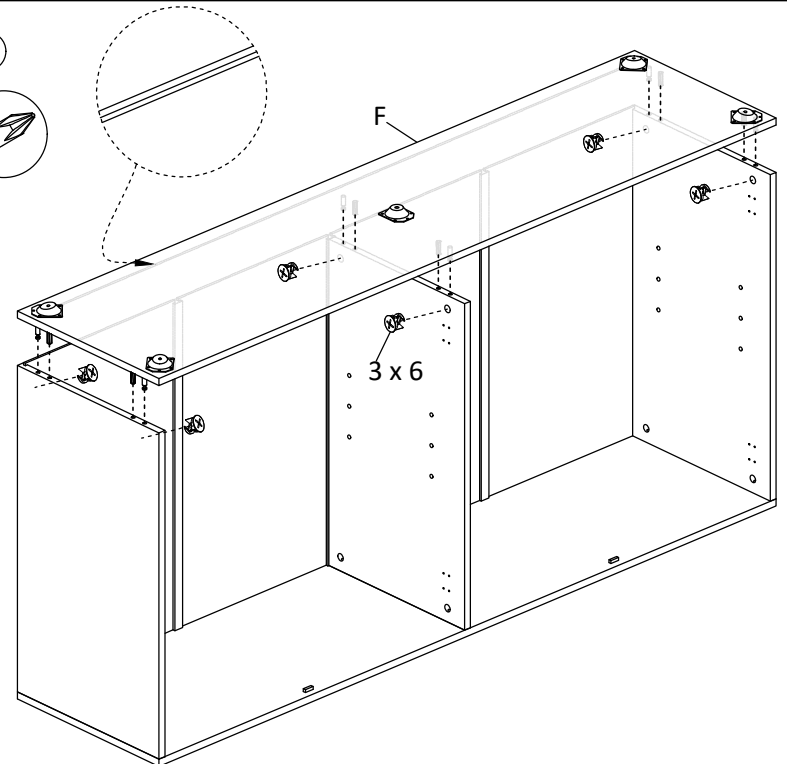
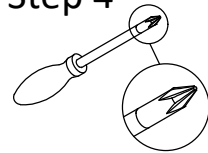

### Step 5

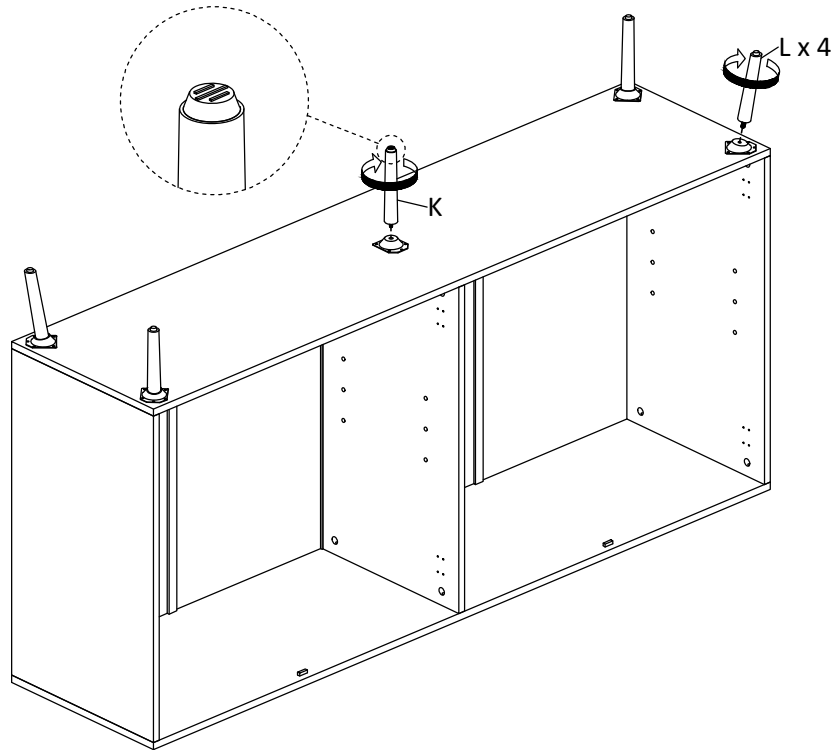

### Step 6

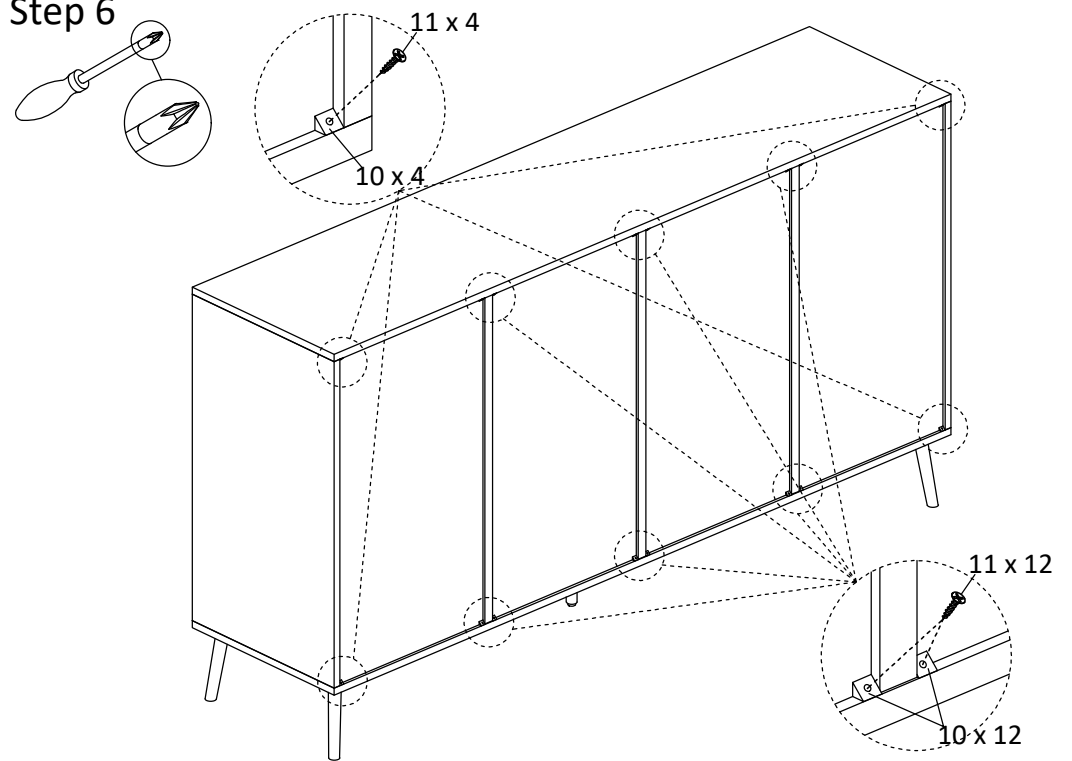

### Step 7

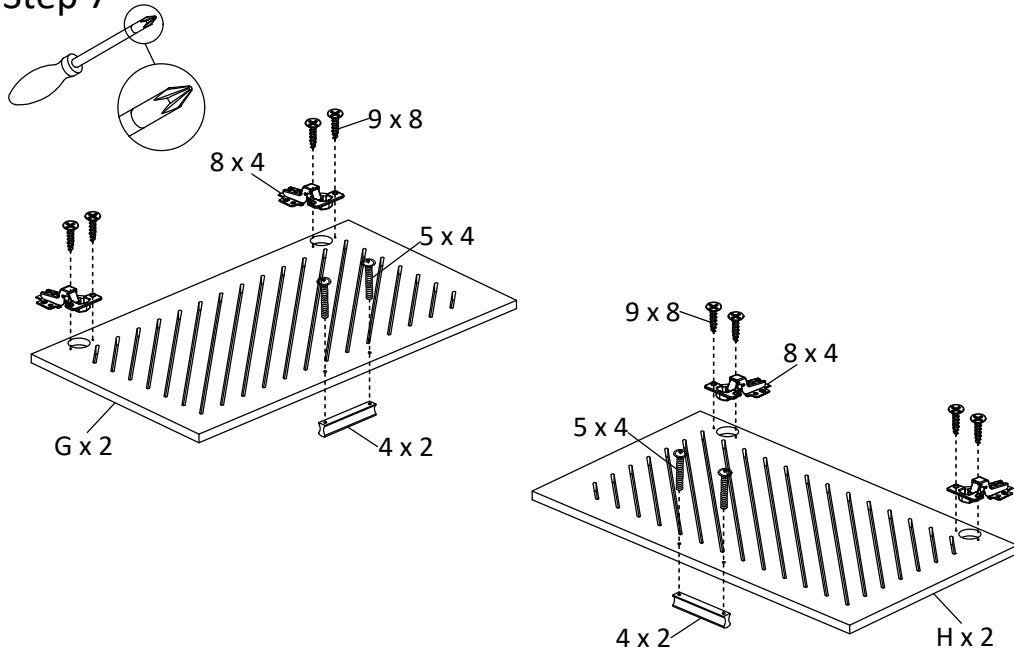

### Step 8

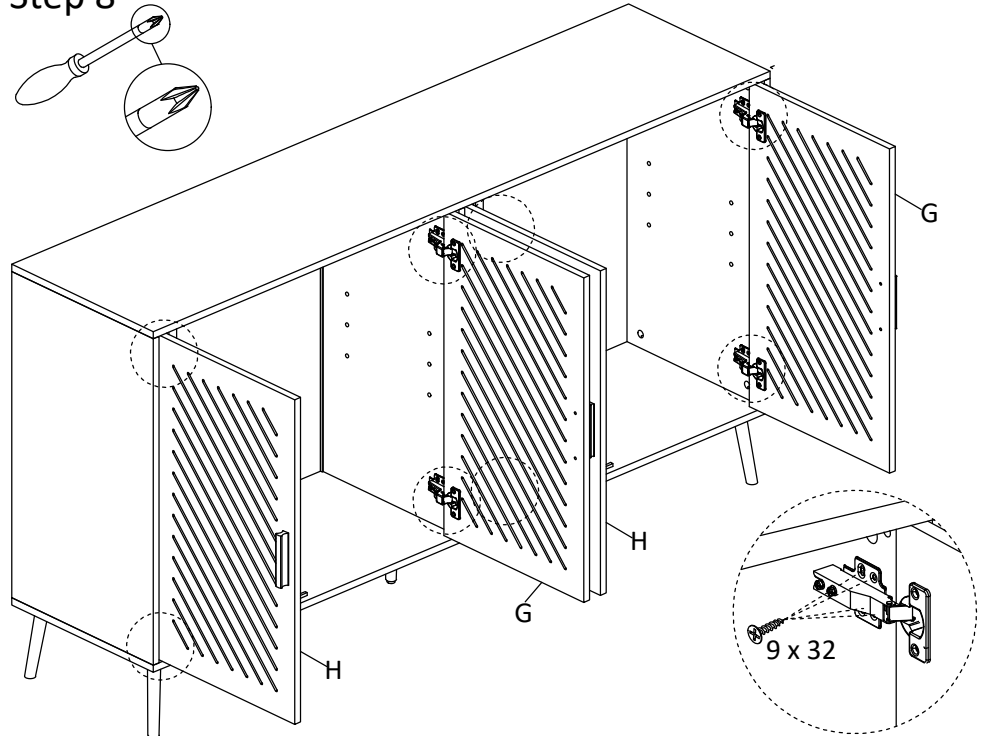

Step 9

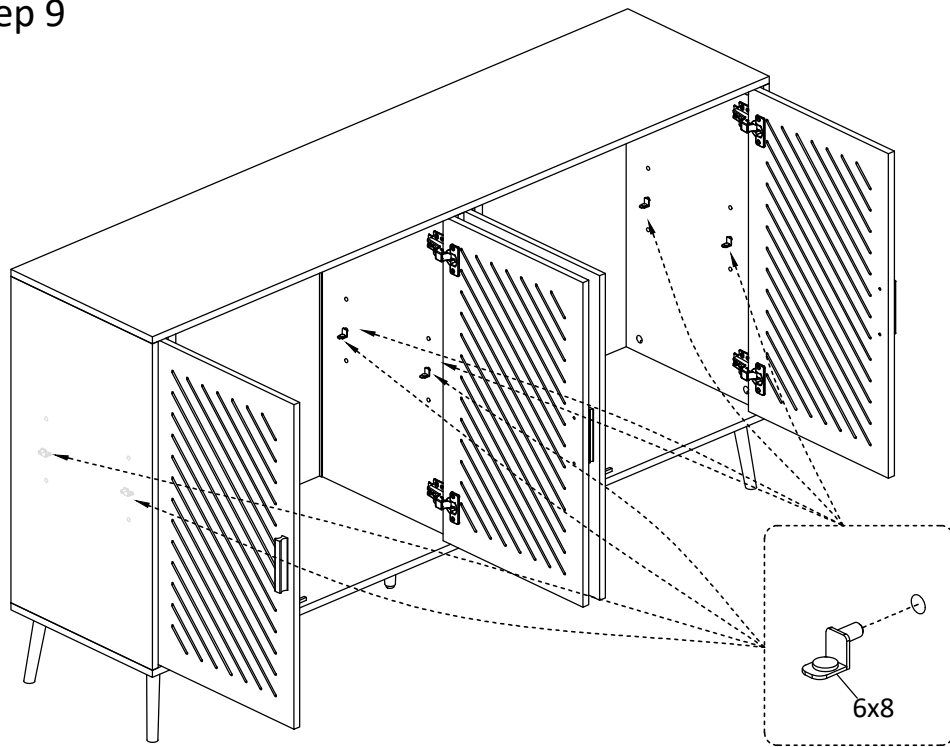

Step 10

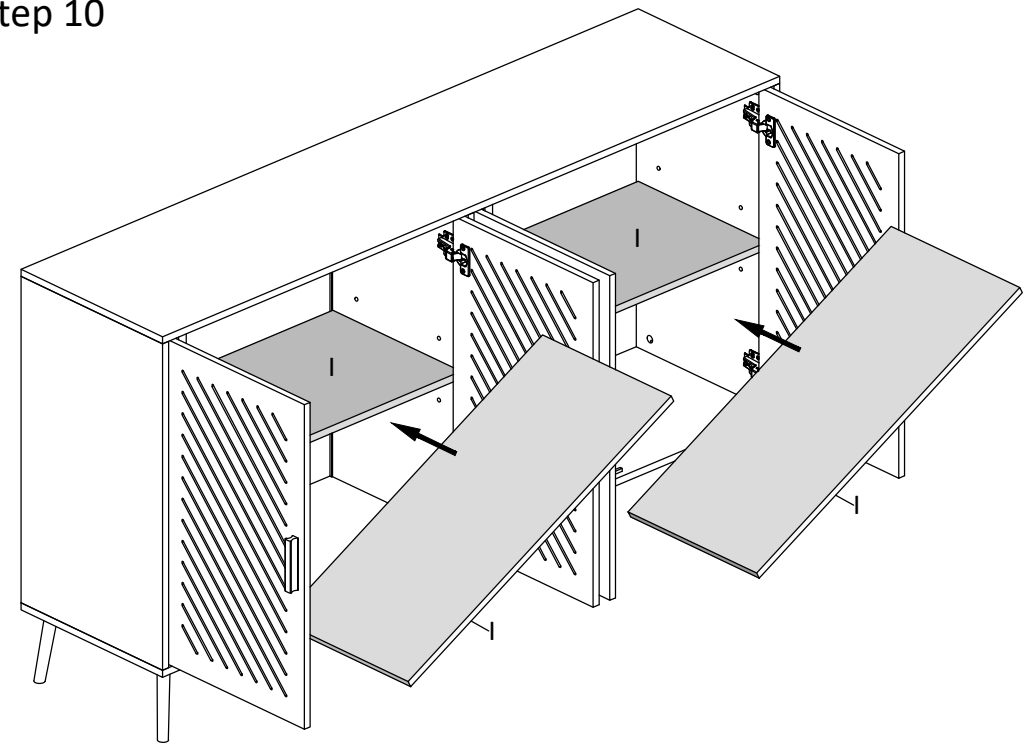

Step 11

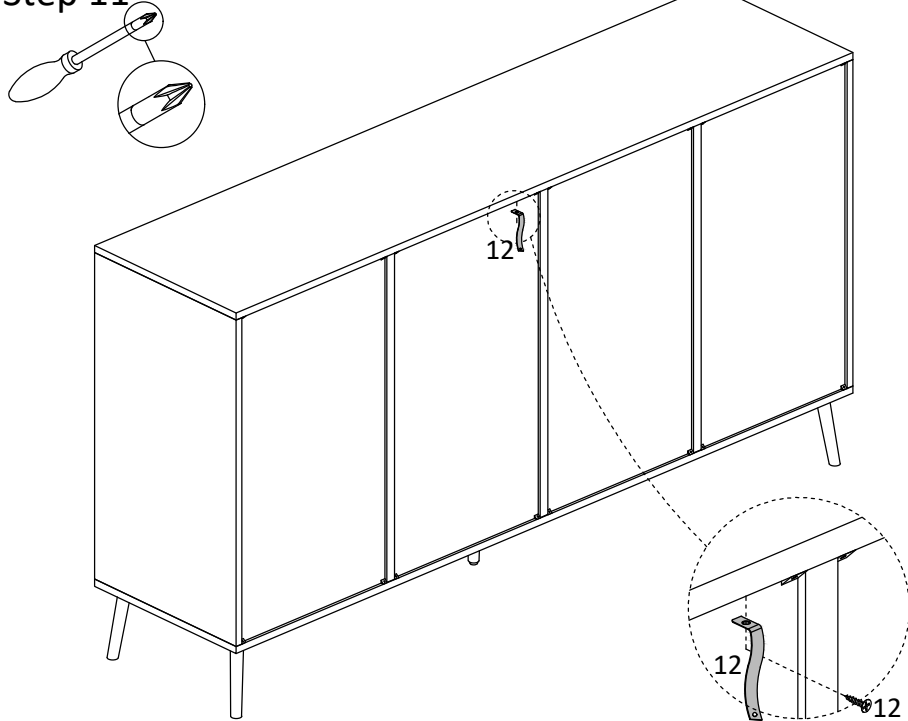

Step 12

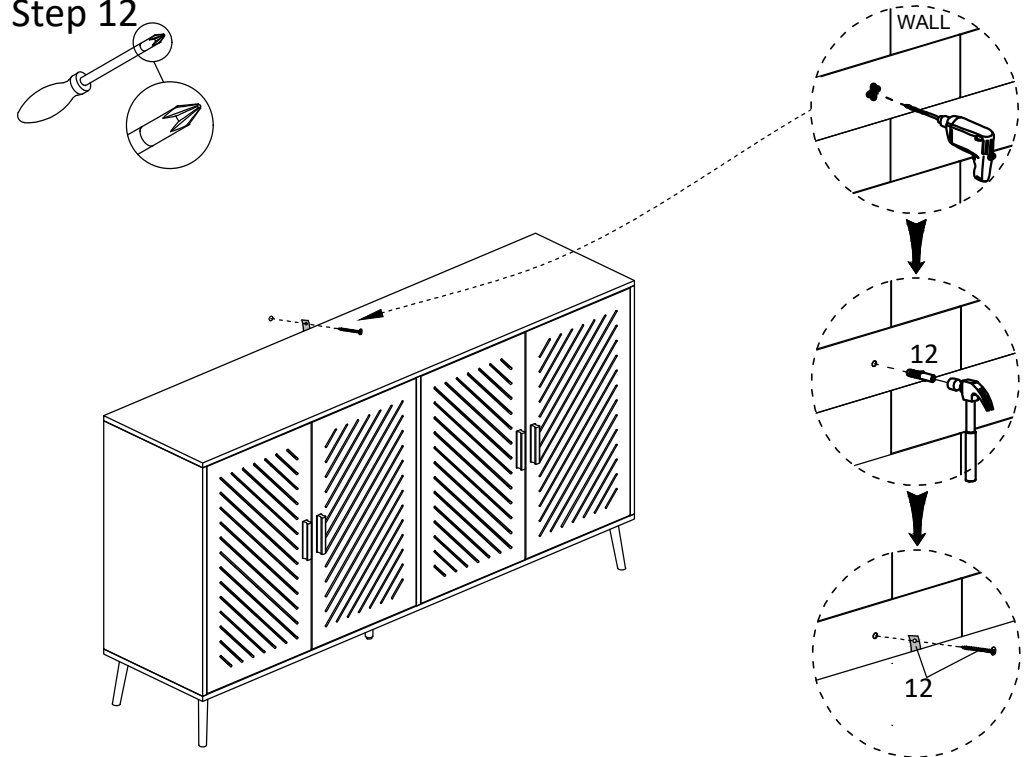

### Step 13

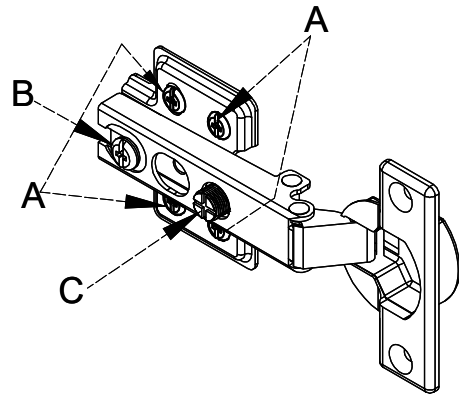

### Step 14

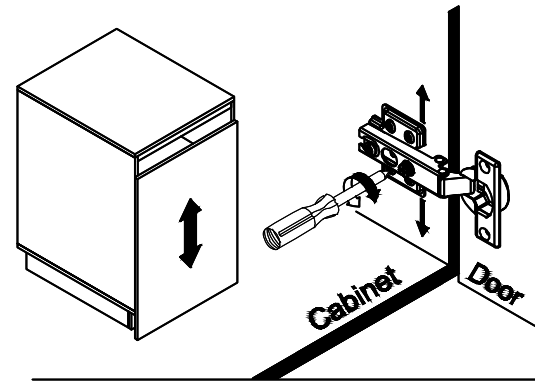

**To adjust the vertical height.**  
Loosen the four screws "A" on both hinges. Two of them are usually in slotted holes which allows you to adjust up or down by a few mm. Then tighten back up.

### Step 15

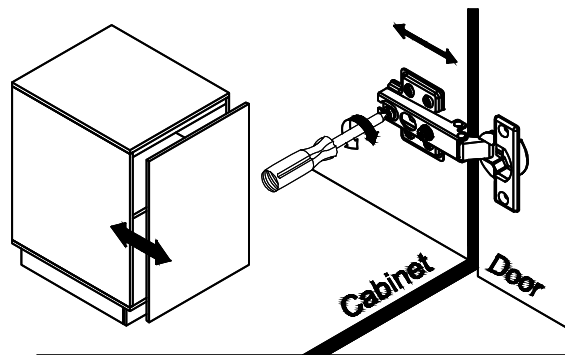

**To adjust depth.**  
Loosen screw "B" and adjust door, if the door cannot be adjusted, please loosen screw "C", then try again. Tighten screw "B" and "C"

### Step 16

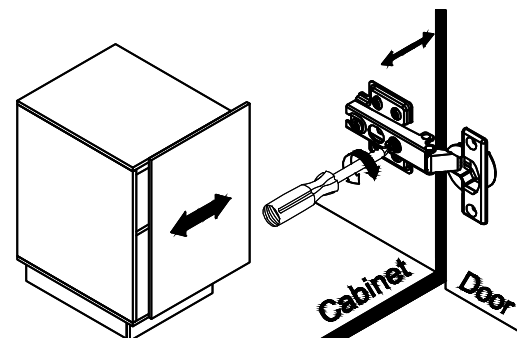

**To adjust side ways.**  
Turning the screw "C" on BOTH hinges on each door.