



☎ 626-679-3588
✉ service@getprohome.com
🌐 www.getprohome.com
📍 162 Atlantic St, Pomona, CA 91768

CARE & MAINTAIN CERAMIC SINK

✉ service@getprohome.com
☎ 626 679 3588



PRODUCT
INSTRUCTION
VIDEO

MODEL No.GP-ADA275-H



Tools and Materials



Safety Glasses



Measuring Tape



Drill



Pencil

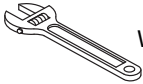

Wrench



Level

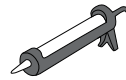

Silicone Caulk

Before You Begin

Read the following instructions carefully before you begin this installation:

1. Observe all local plumbing and building codes.
2. Shut off the hot and cold water supplies. Inspect the drain and supply tubing. Replace if necessary.
3. Unpack the new sink and inspect it for damage. Afterward, put the sink back to its protective carton until the installation begins.
4. In consideration of various installations possible with this sink, procedures other than those described in these instructions may be used.
5. It's recommended to provide the actual sink to all contractors involved in the project. It's critical that all contractors maintain communication and coordinate the requirements of the project.
6. It is recommended that the sink installation be performed by professional and experienced installers. For the sake of safety and a damage-free installation, the sink should be installed by at least two people.
7. All information in these instructions is based on the latest product information available at the time of publication. Eridanus reserves the right to make revisions to the design of products without notice.
8. Due to differing demands and purposes for usage possible, a template will not be provided for this model.

Installation Steps

Wall Mount Installation

NOTE These fixings are suitable for solid walls only. Plasterboard or stud walls may require specialist fixings.

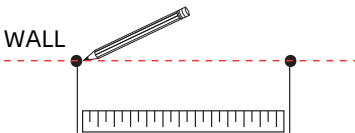
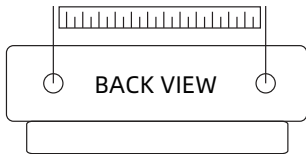

Step 1.

Measure the distance between the center of each mounting hole on the back of the sink. Draw 2 marks on the wall in the desired mounting location. Ensure that the two marks are level with the floor.

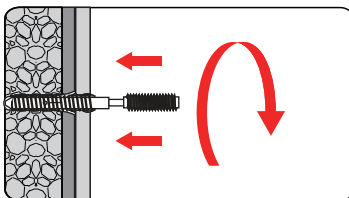
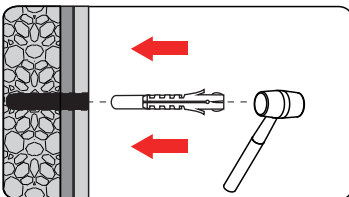
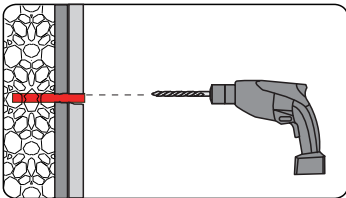

Step 2.

Drill two holes accordingly using a 14 mm masonry drill bit to a depth of 75 mm. Push the anchor into each hole and screw in the hanger bolts.

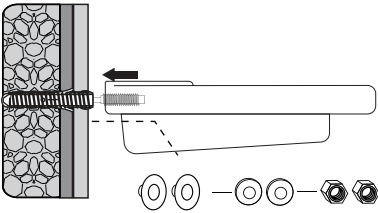

Step 3.

Carefully place the sink in position against the wall. Locate the hanger bolts through the holes in the rear of the basin. Secure the sink with insulation sleeves, washers and nuts respectively.

NOTE DO NOT over-tighten, as this may cause damage to the ceramic sink.

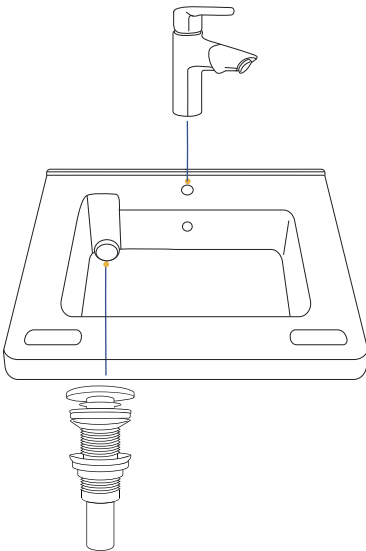

Step 4.

Attach the drain assembly and faucet to the sink according to the manufacturer's instructions.

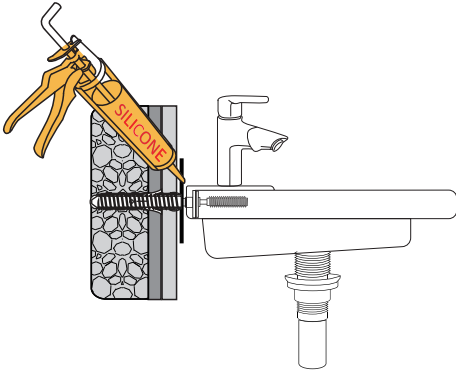

Step 5.

Apply silicone caulk around the edges of the sink where it meets the wall to prevent water from seeping behind the sink. Wait for 24 hours for it to dry.

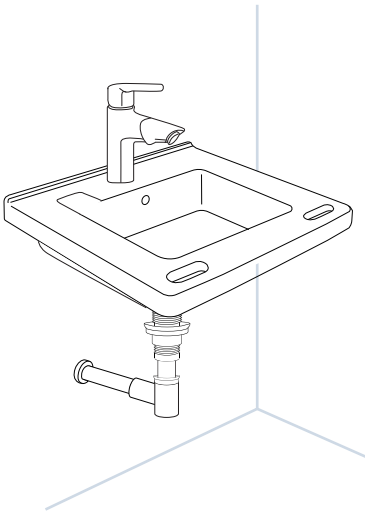

Step 6.

Attach the P-trap assembly to the drain on the sink and connect it to the plumbing below. Install the water supply. Use a wrench to tighten the nuts and ensure there are no leaks.

Congratulations! You have successfully installed a wall mount bathroom sink.

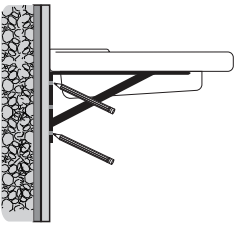

Step 1.

After installing the ceramic sink, place the bracket underneath and mark the hole locations with a pencil.

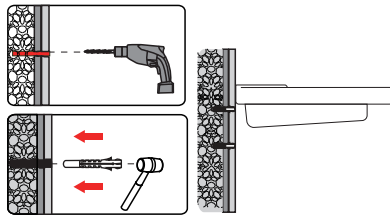

Step 2.

Use an electric screwdriver to drill holes at the marked positions, then push the anchor into each hole.

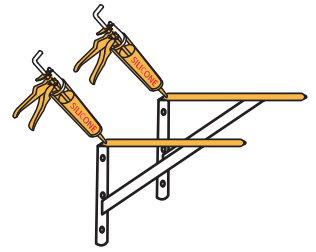

Step 3.

Apply silicone caulk to the top of the sink bracket.

Step 4.

Position the bracket flush against the sink and wall, then secure it with screws.

Prevent water from seeping behind the sink. Wait for 24 hours for it to dry.

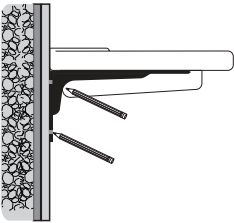
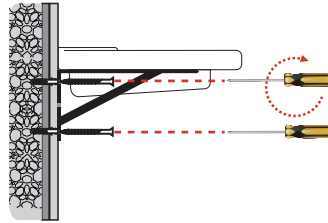

Step 1.

After installing the ceramic sink, place the bracket underneath and mark the hole locations with a pencil.

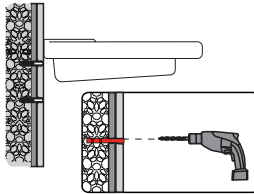

Step 2.

Use an electric screwdriver to drill holes at the marked positions.

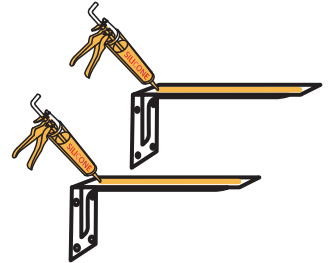

Step 3.

Apply silicone caulk to the top of the sink bracket.

Step 4.

Position the bracket flush against the sink and wall, then secure it with screws.

Prevent water from seeping behind the sink. Wait for 24 hours for it to dry.

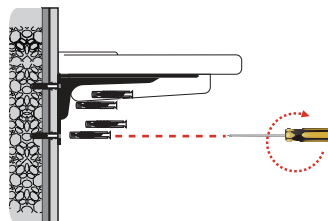

GETPRO ceramic sinks are meticulously handcrafted with fine fireclay or ceramic and have undergone strict quality inspections. With proper care and cleaning measures, GETPRO sinks will keep in new condition and function well for an extended period of time.

General Cleaning

- It's recommended to clean GETPRO sinks on a regular basis to avoid the build-up of soap or mineral deposits.
- When cleaning, use a non-abrasive cleaner and a soft cloth to rinse the sink thoroughly and wipe it dry to eliminate water spots, as allowing water or cleaners to evaporate will have a negative effect on the appearance of the sink.

Do's



- ✓ Rinse laundry detergent thoroughly and make sure there's no residue.
- ✓ Wipe the sink dry using a soft cloth after each use.
- ✓ Scrape off any heavy grime with a plastic spatula.
- ✓ Use baking soda or mild detergent to clean off heavy stains.
- ✓ Test the cleaning solution on an inconspicuous area before applying it to the entire surface.
- ✓ Use a strainer to catch lint and small items like buttons to prevent clogging.



Strainer



Mild
Detergent



Plastic
Scraper

Don'ts



- ✗ Avoid storing open containers of household cleaners and chemicals containing chlorides such as bleach, acid, drain cleaners, or toilet bowl cleaner beneath the sink.
- ✗ Avoid using harsh, abrasive cleaners or chemicals as they will potentially scratch the surface.
- ✗ Avoid direct contact with sharp and metallic objects by using protective plastic bowls, rinse baskets, and sink grids with non-abrasive bases.
- ✗ Never use steel wool, cleaning pads, or any other form of abrasive cleaning materials to clean the sink as this may dull and damage the surface of the sink.
- ✗ Do not set hot pans or other hot items directly into the sink until they cool down.
- ✗ Do not leave any form of standing water in the sink, especially if the water contains anything that could stain the sink.

ONE YEAR LIMITED WARRANTY

LIMITED WARRANTY COVERAGE

1 YEAR LIMITED WARRANTY

Getpro products are made with quality materials and excellent craftsmanship to provide the customers a long-lasting product. In the case of any defects in materials or craftsmanship under regular use were inspected in the first one year of delivery, Getpro will provide replacement parts at no charge, or at its option, replace any product or part of the product that is deemed defective, under normal installation, use, service and maintenance. This warranty applies only to the original purchaser. Proof of purchase will be required in the case of a claim. **SCRATCHES ARE NOT COVERED UNDER WARRANTY.**

The manufacturer warrants this product to be free of manufacture defects during the above mentioned warranty time. Please keep a copy of the original invoice as proof of purchase.

Getpro will, as its option, (1) repair or replace the defective part(s) or product(s) at no charge; (2) issue a refund of the original purchase price of the product(s) (Valid within 30 days from the date of delivery); or (3) issue a credit to be applied toward the purchase of a new Getpro product shipping/delivery charges may apply and are in Getpro sole discretion.

Getpro recommends the installations to be made by a licensed, professional plumber. Getpro will not be held responsible for any damage or product failure due to improper installation, misuse, or failure to use a licensed professional. Getpro is not responsible for any removal or installation cost.

This limited warranty shall not apply to goods which have been subject to accident, negligence, improper installation, product abuse, product misuse, or use of cleaners containing abrasives, alcohol or other organic solvents, whether performed by a contractor, service company, or yourself, are excluded from this warranty.

Getpro responsibility under this limited warranty is limited to only to replacement parts and no other costs. Getpro will not be responsible for labor charges and/or damage incurred by installation, repair or replacement, nor for any indirect incidental or consequential damages, losses, injury or costs of any nature relating to this product Except as provided by law, this limited warranty is in lieu of and excludes all other warranties, conditions, and guarantees, whether expressed or implied, statutory or otherwise, including without restriction those merchantability of fitness for use.

RESPONSIBILITIES OF OTHERS

Inspecting the unit prior to installation is the responsibility of the installer or building contractor who acts on behalf of the user. They are responsible for ensuring the unit is free of defect or damage.

Notices are placed on and in the unit and on the shipping carton advising the installer of this responsibility.

In the event of a problem, the unit must not be installed. Getpro is not responsible for failures or damage that could have been discovered, repaired, or avoided by proper inspection and testing prior to installation.

Damage occurring in transit is the responsibility of the carrier. The user or installer **MUST** open the crate and inspect the unit for damage when it is delivered. If damage is discovered, it must be reported immediately to the seller and the carrier in writing, and an inspection requested. Failure of the carrier to respond should be reported to the seller and the carrier. Your freight claims should be filed promptly thereafter.

LIMITATIONS AND EXCLUSIONS

This warranty does not cover instances of negligence, misuse, abuse, improper installation, carelessness, accident, hard water or mineral deposits, exposure to corrosive materials, misapplication, damages caused by improper maintenance, alteration of the product, or failure to follow care or installation instructions enclosed with your product. This warranty is void if the Getpro is subject to alteration, or if repairs are attempted by anyone other than an authorized agent of Getpro. This warranty does not extend to plumbing or components installed by dealers, installers or by any party other than Getpro.

Getpro will not be liable for loss of use of the Getpro inconvenience, or any other incidental or consequential costs, expense or damages. Please note that some states do not allow the exclusion or limitation of incidental damages.

DISCLAIMER

Except as expressly provided, there shall be no warranty or obligation, express or implied, oral or statutory. No dealer or other person has the authority to make any warranties or representations concerning Getpro or its products. In no event shall Getpro be held responsible for any such warranties or representations.

WARRANTY SERVICE

NOTE: When requesting warranty, be sure to have the following:

- Copy of original invoice
- Date of installation
- Description and pictures of defect
- Model number or description of model

To obtain warranty service and replacement part, please contact Getpro Customer Service. Getpro will determine whether to repair or replace your product, issue a refund, or issue a credit.

HOME SERVICES



INSTALLATION VIDEO

Missing Part or Defective?

Please Contact the Customer Service Team

✉ service@getprohome.com

☎ 626 679 3588